

(12) PATENT
(19) AUSTRALIAN PATENT OFFICE

(11) Application No. AU 199731520 B2
(10) Patent No. 739665

(54) Title
Apparatus and method for reconstructing ligaments

(51)⁷ International Patent Classification(s)
A61B 017/16

(21) Application No: **199731520**

(22) Application Date: **1997.06.03**

(87) WIPO No: **WO97/46162**

(30) Priority Data

| | | |
|------------------|-------------------|--------------|
| (31) Number | (32) Date | (33) Country |
| 08/658003 | 1996.06.04 | US |

(43) Publication Date : **1998.01.05**

(43) Publication Journal Date : **1998.02.26**

(44) Accepted Journal Date : **2001.10.18**

(71) Applicant(s)
Joseph H. Sklar

(72) Inventor(s)
Joseph H. Sklar

(74) Agent/Attorney
PHILLIPS ORMONDE and FITZPATRICK,367 Collins Street,MELBOURNE VIC 3000

(56) Related Art
US 5383884
US 2429356
US 4445509

CORRECTED
VERSION*

PCT

31520/97



pages 1-29, description, and pages 30-37, claims, replaced by new pages bearing the same number; pages 1/23-23/23, drawings, replaced by new pages 1/20-20/20; due to late transmittal by the receiving Office

INTERNATIONAL APPLICATION PUBLISHED UNDER THE PATENT COOPERATION TREATY (PCT)

| | | |
|--|--|---|
| (51) International Patent Classification ⁶ : A61B 17/16 | A1 | (11) International Publication Number: WO 97/46162 (43) International Publication Date: 11 December 1997 (11.12.97) |
| (21) International Application Number: PCT/US97/09431 (22) International Filing Date: 3 June 1997 (03.06.97) (30) Priority Data: 08/658,003 4 June 1996 (04.06.96) US (71)(72) Applicant and Inventor: SKLAR, Joseph, H. [US/US]; 210 Park Drive, Longmeadow, MA 01106 (US). (74) Agent: PANDISCIO, Mark, J.; Pandiscio & Pandiscio, 470 Totten Pond Road, Waltham, MA 02154 (US). | (81) Designated States: AU, CA, JP, European patent (AT, BE, CH, DE, DK, ES, FI, FR, GB, GR, IE, IT, LU, MC, NL, PT, SE). Published <i>With international search report.</i> <div data-bbox="893 795 1284 1041" style="border: 1px solid black; padding: 5px; text-align: center;">AUSTRALIAN INDUSTRIAL 14 APR 1998 PROPERTY ORGANISATION</div> | |

(54) Title: APPARATUS AND METHOD FOR RECONSTRUCTING LIGAMENTS

(57) Abstract

This invention is an apparatus for removing bone from a femoral notch, which includes a guidewire (50) and a router assembly (55). The router assembly comprises a cutting head (67) fixed to a shaft (70) rotatably disposed in a hole through a body portion (80) of a shield assembly (75). A hood portion (85) of the shield assembly extends from the body portion of the shield assembly, and covers a first portion of the cutting head while leaving exposed a second portion of the cutting head. The guidewire extends through a hole (95) in the shaft, cutting head, and shield assembly hood portion such that the router assembly (55) is movable along the guidewire. The shaft (70) is rotatable in the shield assembly body portion, such that the second portion of the cutting head is engageable with the bone and operative to remove portions of the bone.

50

10

55

15

50

*(Referred to in PCT Gazette No. 13/1998, Section II)

APPARATUS AND METHOD FOR RECONSTRUCTING LIGAMENTSField Of The Invention

This invention relates to medical apparatus and methods in general, and more particularly to apparatus and methods for reconstructing ligaments.

Background Of The Invention

Ligaments are tough bands of tissue which serve to connect the articular extremities of bones, or to support or retain organs in place within the body. Ligaments are typically composed of coarse bundles of dense white fibrous tissue which are disposed in a parallel or closely interlaced manner, with the fibrous tissue being pliant and flexible, but not extensible.

In many cases, ligaments are torn or ruptured as a result of accidents. As a result, various procedures have been developed to repair or replace such damaged ligaments.

For example, in the human knee, the anterior and posterior cruciate ligaments (i.e., the ACL and PCL) extend between the top end of the tibia and the bottom end of the femur. The ACL and PCL cooperate, together with other ligaments and soft tissue, to provide both static and dynamic stability to the knee. Often, the anterior cruciate ligament (i.e., the ACL) is ruptured or torn as a result of, for example, a sports-related injury. Consequently, various surgical procedures have been developed for

reconstructing the ACL, so as to restore normal function to the knee.

In many instances, the ACL may be reconstructed by replacing the ruptured ACL with a synthetic or harvested graft ligament. More particularly, with such procedures, bone tunnels are typically formed in the top end of the tibia and the bottom end of the femur, with one end of the graft ligament being positioned in the femoral tunnel and the other end of the graft ligament being positioned in the tibial tunnel. The two ends of the graft ligament are anchored in place in one of a variety of ways so that the graft ligament extends between the femur and the tibia in substantially the same way, and with substantially the same function, as the original ACL. This graft ligament then cooperates with the surrounding anatomical structures so as to restore normal function to the knee.

It will, of course, be appreciated that a complex interdependency exists between the ACL and the other elements of the knee, e.g., the bones, the other knee ligaments, and other soft tissue. Consequently, it is critical that the graft ACL be disposed in exactly the right position relative to the other anatomical structures of the knee if normal knee function is to be restored. Correspondingly, it has been found that the aforementioned bone tunnels must be precisely positioned in the tibia and femur if successful reconstruction of the ACL is to be achieved. Unfortunately, proper positioning of these bone



tunnels to satisfy isometric considerations can sometimes lead to anatomical conflicts within the knee when the graft ACL is installed within the knee.

More particularly, the ACL normally extends between the bottom end of the femur and the top end of the tibia, with the body of the ACL passing through the femur's intercondylar notch and across the interior of the knee joint. See, for example, Figs. 1 and 2, which show a natural ACL 5 extending between the bottom end of a femur 10 and the top end of a tibia 15, with the body of ACL 5 passing through the femur's intercondylar notch 20. Also shown is a natural PCL 25 extending between the bottom end of femur 10 and the top end of tibia 15.

It is to be appreciated that the position of the various knee elements move relative to one another as the knee is flexed through a range of natural motions. See, for example, Fig. 3, which shows ACL 5 moving across a 40° arc as the knee joint is flexed through a 140° motion.

Due to the complex geometries of the knee, where a damaged ACL is to be replaced by a graft ACL, it is critical that the graft ACL be connected at precisely the right locations on the bottom end of the femur and top end of the tibia. Thus, and looking now at Figs. 4 and 5, where a damaged ACL is to be replaced by a graft ACL, the damaged ACL is first cleared away and then bone tunnels 30 and 35 are formed in the tibia and femur, respectively. The precise locations of these bone tunnels

30 and 35 are dictated by the isometric relationships of the knee. In practice, bone tunnels 30 and 35 are formed using a surgical drill guide which is keyed to certain parts of the patient's anatomy, e.g., to the patient's tibial plateau. Once bone tunnels 30 and 35 have been formed, the graft ACL may be installed in ways well known in the art. See, for example, Figs. 6 and 7, which show a graft ACL 5A having one end mounted to femur 10 and the other end mounted to tibia 15.

Unfortunately, in some situations, proper isometric placement of bone tunnels 30 and 35 may cause anatomical conflicts within the knee when the graft ACL is installed in the patient. By way of example, and of particular interest in connection with the present invention, proper isometric placement of bone tunnels 30 and 35 may result in portions of the femur impinging upon the graft ACL as the knee is moved through its full range of natural motions. See, for example, Fig. 8, which shows one of the femur's condyles 40 impinging upon a graft ACL 5A extending through the femur's intercondylar notch 20; and Fig. 9, which shows the roof the femur's intercondylar notch impinging on the graft ACL 5A in the vicinity of arrow 42.

Impingement can occur for a variety of reasons. For one thing, the intercondylar notch of many patients (particularly those who are susceptible to rupture of the ACL) is frequently small to begin with. For another thing, the graft ACL (i.e., the

synthetic or harvested graft ligament which is being installed in place of the damaged natural ACL) is generally fairly large.

Additionally, slight mispositioning of bone tunnels 30 and 35 can also lead to impingement problems.

Unfortunately, impingement of the femur on the graft ligament can reduce the effectiveness of the ACL reconstruction procedure or even cause it to fail altogether.

Thus, when performing an ACL reconstruction procedure, the surgeon generally tries to ensure that there is sufficient room within the patient's intercondylar notch to receive the graft ligament. This is generally done by performing notchplasty, i.e., by surgically removing any impinging bone from the sides and/or roof of the intercondylar notch. At the same time, of course, it is also important that the surgeon remove no more bone than is absolutely necessary, so as to minimize trauma to the patient.

Unfortunately, it is difficult for the surgeon to accurately gauge the precise amount of bone that must be removed from the notch in order to avoid impingement. For one thing, the ACL reconstruction procedure is typically performed arthroscopically, so that the surgeon's view of the surgical site is frequently fairly restricted. For another thing, the surgeon typically will not know the precise space that the graft ACL will occupy until the graft is actually in place; but at that point in the procedure, it is frequently difficult to insert additional bone-

6

cutting instruments into the joint so as to remove more bone, particularly without cutting the graft ACL. Furthermore, experience has shown that the most serious problems with impingement occur superiorly; but even with the graft ligament in place, the surgeon is generally unable to see impingement at this location due to limitations in arthroscopic visualisation. Also, the surgeon typically performs the ACL reconstruction procedure in a relatively static context, i.e., with the knee being relatively stationary at any given moment during the reconstruction procedure. However, the knee must perform (and impingement must be avoided) in a relatively dynamic context, i.e., as the knee is moved throughout a full range of natural motions. This complicates the surgeon's task of eliminating impingement.

Desirabilities of the Invention

Accordingly, it would be desirable to provide improved apparatus for reconstructing a ligament.

It would also be desirable to provide improved apparatus for reconstructing an anterior cruciate ligament (ACL).

It would also be desirable to provide improved apparatus for quickly, easily and reliably eliminating impingement problems when reconstructing an anterior cruciate ligament.

It would be yet further desirable to provide improved apparatus for quickly, easily and reliably removing any anatomical structures (e.g. bone) which will conflict with the location of a graft ACL at the completion of an ACL reconstruction procedure.

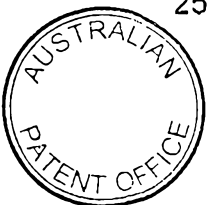

It would be yet further desirable to provide improved apparatus for quickly, easily and reliably removing any anatomical structures (e.g., bone) which will conflict with the location of a graft ACL as the knee is moved through a full range of natural motions.

5

It would be yet further desirable to provide an improved method for reconstructing a ligament.

It would be yet further desirable to provide an improved method for reconstructing an anterior cruciate ligament (ACL).

It would be yet further desirable to provide an improved method for quickly, easily and reliably eliminating impingement problems when reconstructing an anterior cruciate ligament.

Still it would be yet further desirable to provide an improved method for quickly, easily and reliably removing any anatomical structures (e.g., bone) which will conflict with the location of a graft ACL at the completion of an ACL reconstruction procedure.

Still it would be yet further desirable to provide an improved method for quickly, easily and reliably removing any anatomical structures (e.g., bone) which will conflict with the location of a graft ACL as the knee is moved through a full range of natural motions.

25



The above discussion of documents, acts, materials, devices, articles and the like is included in this specification solely for the purpose of providing a context for the present invention. It is not suggested or represented that any of these matters formed part of the prior art base or were common general knowledge in the field relevant to the present invention as it existed in Australia before the priority date of each claim of this application.

Summary of the Invention

10 According to one aspect of the present invention, there is provided apparatus for removing portions of a bone, said apparatus including:

a router assembly including:

a cutting head fixed to a shaft; and

15 a shield assembly having a body portion and a hood portion, said body portion having a hole therethrough for receiving said shaft, said hood portion extending from one end of said body portion and defining a concavity in which is disposable in part said cutting head; and

20 a guidewire constructed from a highly elastic yet firm material, enabling the router assembly to cut away bone even if the guidewire is flexed relative to the bone.

According to another aspect of the present invention, there is provided apparatus for removing portions of a bone, said apparatus including:

a guidewire; and

25 a router assembly;

said router assembly including a cutting head fixed to a shaft rotatably disposed in a hole through a body portion of a shield assembly, and a hood portion

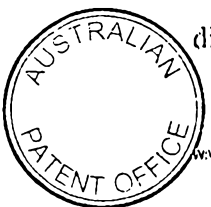

of said shield assembly extending from said body portion of said shield assembly and covering a first portion of said cutting head while leaving exposed a second portion of said cutting head;

5 said guidewire extending through a bore in said shaft, a bore in said cutting head, and a hole in said shield assembly hood portion, such that said router assembly is movable along said guidewire and said shaft is rotatable in said shield assembly body portion, such that said second portion of said cutting head is engageable with the bone and is operative to remove portions of the bone, and

10 wherein said guidewire is constructed from a highly elastic yet firm material, enabling the router assembly to cut away bone even if the guidewire is flexed relative to the bone.

15 According to another aspect of the present invention, there is provided apparatus for removing portions of a bone, said apparatus comprising a cutting head fixed to a shaft, and a guidewire extendible through a bore extending through said shaft and said cutting head, such that said cutting head is movable along said guidewire, said cutting head being devoid of cutting means on a first portion of the periphery thereof and having cutting means on a second portion of the periphery thereof, said second portion of said cutting head being engageable with the bone
20 portions to be removed, said shaft and cutting head being rotatably movable in an oscillating fashion such that said cutting head second portion moves in alternating opposite directions across the bone portions to remove portions thereof, said first portion being smooth and non-destructive with respect to anatomical structures with which said first portion comes into contact.

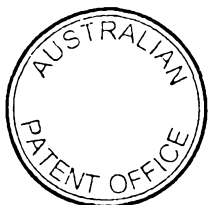

guidewire to engage bone portions proximate said guidewire and mark said bone portions for said subsequent removal.

According to another aspect of the present invention, there is provided a method
5 for removing portions of a bone said method comprising the steps of:

providing (i) a guidewire, and (ii) a router assembly comprising a cutting head fixed to a shaft rotatably disposed in a hole through a body portion of a shield assembly, and a hood portion of said shield assembly extending from said body portion of said shield assembly and covering a first portion of said cutting head while leaving exposed
10 a second portion of said cutting head, said shaft and said cutting head having bores therethrough, and said shield assembly hood portion having a hole therein;

anchoring said guidewire in the bone;

mounting said router assembly on said guidewire such that said guidewire extends through said shaft bore, said cutting head bore, and said hood portion hole, and
15 moving said router assembly along said guidewire to proximate the bone;

positioning said router assembly such that said second portion of said cutting head is directed toward the bone portion to be removed, and rotating said shaft, to rotate said cutting head, to remove portions from the bone, while the shield assembly hood portion separates said cutting head from other anatomical structures, and

20 wherein the guidewire is constructed from a highly elastic yet firm material enabling the router assembly to cut away bone even if the guidewire is flexed relative to the body.

According to another aspect of the present invention, there is provided a method
25 for reconstructing an anterior cruciate ligament (ACL) of a patient using a graft ACL, said method comprising the steps of:



12

extending the patient's knee at an angle of approximately 90°;

forming a bone tunnel in the patients tibia;

passing a guidewire through said tibial bone tunnel and into the patient's femur,
said guidewire being positioned so as to extend along the length where the graft ACL

5 will thereafter reside;

positioning a cannulated router device onto said guidewire;

performing notchplasty on said femur using said cannulated router device as said
cannulated router device is mounted on said guidewire and as said knee is moved
through a range of natural motions; and

10 dismantling said cannulated router device from said guidewire.



Brief Description of the Drawings

These and other features of the present invention will be more fully disclosed or rendered obvious by the following detailed description of the preferred embodiments of the invention, which are to be considered together with the accompanying drawings
5 wherein like numbers refer to like parts and further wherein:

Fig. 1 is a schematic front view of a normal knee, where the leg is substantially straight;

Fig. 2 is a schematic side view, partially in section, of the knee shown in Fig. 1;

10 Fig. 3 is a schematic side view, showing how the ACL moves about within the knee joint as the knee is flexed through a range of natural motions;

15 Fig. 4 is a schematic front view of a knee, where the knee is bent at approximately a 90° angle, and where a damaged ACL has been removed and bone tunnels have been formed in the tibia and the femur;

Fig. 5 is a schematic side view of the knee shown in Fig. 4;

Fig. 6 is a schematic front view of a knee, where the knee is bent at approximately a 90° angle, showing a graft ACL installed in the knee;

Fig. 7 is a schematic side view of the knee shown in Fig. 6;

20 Fig. 8 is a schematic front view showing how portions of the femur can impinge upon a graft ACL;

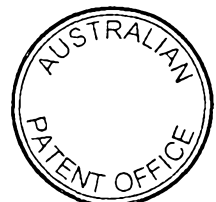

Fig. 9 is a schematic side view showing how portions of the femur can impinge upon a graft ACL;

Fig. 10 is a schematic side view of the guidewire used in connection with the present invention;

Fig. 11 is a schematic perspective view showing one form of router assembly formed in accordance with the present invention;

Fig. 12 is a schematic perspective view of the router assembly's cannulated router device;

Fig. 13 is a schematic side view, in section, of the cannulated router device shown in Fig. 12;

Fig. 14 is a schematic side view, in section, of a portion of the router assembly's shield assembly;

Fig. 15 is a schematic perspective view of the shield assembly's collar;

Fig. 16 is a schematic side view, in section, of the router assembly shown in Fig. 11;

Fig. 17 is a schematic side view of a knee, where the knee is bent at approximately a 90° angle, and where a damaged ACL has been removed and a bone tunnel has been formed in the tibia, and showing a guidewire extending through the tibial bone tunnel and into the femur;

Fig. 18 is a schematic side view of the knee shown in Fig. 17;

Fig. 19 is a schematic front view like that of Fig. 17, except showing a router assembly removing lateral bone structures

from the femoral notch so as to prevent those lateral bone structures from impinging on a graft ACL;

Fig. 20 is a schematic side view showing a router assembly removing lateral bone structures from the femoral notch so as to prevent those lateral bone structures from impinging on a graft ACL;

Fig. 21 is a schematic front view, showing the leg substantially straight and the router assembly removing roof bone structures from the femoral notch so as to prevent those roof bone structures from impinging on a graft ACL;

Fig. 22 is a schematic side view of the knee and router assembly shown in Fig. 21;

Fig. 23 is a schematic side view, showing the knee flexed at approximately a 140° angle and the router assembly removing bone structures from the femoral notch so as to prevent those bone structures from impinging on a graft ACL;

Fig. 24 is a schematic perspective view showing an alternative form of router assembly formed in accordance with the present invention;

Fig. 25 is a schematic perspective view showing the collar used in connection with the router assembly shown in Fig. 24;

Fig. 26 is a schematic side view, in section, of the router assembly shown in Fig. 24;

Fig. 27 is a schematic perspective view of another form of router device which can be used in connection with the present invention;

Fig. 28 is a schematic perspective view of yet another form of router device which can be used in connection with the present invention;

Fig. 29 is a schematic side view of a cannulated marking device formed in accordance with the present invention; and

Fig. 30 is a schematic side view of a novel type of guidewire assembly formed in accordance with the present invention.

Detailed Description Of The Preferred Embodiments

Looking first at Figs. 10-16, the present invention provides apparatus and a method for removing bone structures from the femoral notch so as to prevent those bone structures from impinging upon a graft ACL installed as part of an ACL reconstruction procedure. The apparatus and method of the present invention are intended to be utilized in an ACL reconstruction procedure after the damaged ACL has been removed from the knee and after bone tunnel 30 has been formed in tibia 15, but before bone tunnel 35 has been formed in femur 10 and the graft ACL has been positioned in the joint.

Still looking now at Figs. 10-16, in one preferred embodiment of the present invention, the apparatus of the present

invention comprises a guidewire 50 (Figs. 10 and 11) and a router assembly 55 (Figs. 11-16).

Guidewire 50 is generally of the sort for guiding cannulated elements to a target structure. As such, guidewire 50 includes a sharp point 60 (Fig. 10) on its distal end, whereby the guidewire can be drilled or tapped into a target structure (e.g., femur 10, as will hereinafter be described in further detail). In accordance with one preferred embodiment of the present invention, guidewire 50 is preferably formed out of a highly elastic yet firm material. Preferably, guidewire 50 is formed out of a so-called pseudoelastic material, i.e., a "shape memory alloy (SMA)/stress induced martensite (SIM)" material such as Nitinol. By forming guidewire 50 out of such a highly elastic yet firm material, the guidewire has the rigidity needed to penetrate into bone, yet has the high elasticity needed to undergo substantial elastic deformation during joint flexure, as will hereinafter be described in further detail.

Still looking now at Figs. 11-16, router assembly 55 comprises a cannulated router device 65 (Figs. 11-13 and 16) which comprises a cannulated cutting head 67 attached to a cannulated shaft 70. At least the distal portion 70' (Figs. 12, 13 and 16) of cannulated shaft 70 is flexible; the proximal portion 70" of cannulated shaft 70 may or may not be flexible, as desired. On account of this construction, cannulated router

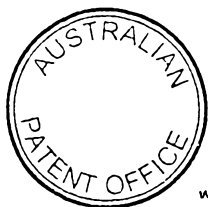

device 65 can ride on guidewire 50 as rotary cutting motion is imparted to cutting head 67 by means of shaft 70. In particular, by forming at least the distal portion 70' of cannulated shaft 70 so as to be flexible, router device 65 can ride on guidewire 50 and rotate even as guidewire 50 is subjected to substantial bending during knee joint flexure, as will hereinafter be discussed in further detail.

Router assembly 55 also comprises a shield assembly 75 (Figs. 11 and 14-16). Shield assembly 75 comprises a body assembly 80 and a hood 85.

Body assembly 80 comprises a hollow outer tube 82 (Figs. 14 and 16) and an inner collar 83 (Figs. 15 and 16). At least the distal portion 82' (Figs. 14 and 16) of hollow outer tube 82 is flexible; the proximal portion 82" of hollow outer tube 82 may or may not be flexible, as desired. Collar 83 is sized and positioned so as to terminate at the juncture of the hollow tube's distal portion 82' and its proximal portion 82" (Fig. 16). Collar 83 includes a hole 90 (Figs. 15 and 16) for receiving shaft 70 of router device 65. Hole 90 is preferably centered within body 80, whereby the router device's cutting head 67 will be centered within shield assembly 75.

Hood 85 is attached to body 80 and includes a hole 95 (Figs. 14 and 16) for receiving guidewire 50. Hood 85 surrounds a portion of the router device's cutting head 67 but leaves another portion of the cutting head (i.e., the portion extending outboard

of hood 85) exposed for routing operations. By way of example but not limitation, hood 85 might cover approximately 2/3 of the circumferential region surrounding cutting head 67 and leave
5 approximately 1/3 of the circumferential region surrounding cutting head 67 exposed for cutting purposes. Shield 85 may be formed flexible or rigid, as desired.

As a result of this construction, router assembly 55 can ride on guidewire 50 as a unit, with shaft 70 rotating cutting head 67 so as to cut away any material (e.g., impinging bone) exposed to the cutting head, even as hood 85 shields a
10 substantial portion of the cutting head from inadvertently cutting other material (e.g., the patient's PCL). Significantly, due to the flexible nature of shaft portion 70' and tube portion 82', router assembly 55 is able to ride on guidewire 50 even as
15 guidewire 50 is subjected to substantial deformation during knee joint flexure.

Looking next at Figs. 17-23, guidewire 50 and router assembly 55 are intended to be used as follows.

First, femur 10 and tibia 15 are set at approximately a 90° angle and tibial bone tunnel 30 is formed in tibia 15. Then guidewire 50 is passed through tibial bone tunnel
20 30 and into femur 10 until the sharp distal end 60 of the guidewire is embedded in the femur, e.g., by drilling or tapping (See Figs. 17 and 18). If desired, a cannulated guide (not shown) may be



disposed about guidewire 50 to help stabilize it as it is
embedded into femur 10. Guidewire 50 is positioned in the
patient so that it will extend along the length where the graft
5 ACL will reside.

Next, router assembly 55 is loaded onto the proximal end of
guidewire 50 and moved down into the interior of the knee joint
so that the router assembly's cutting head 67 is in the vicinity
of femoral notch 20 (see Figs. 19 and 20). Then body 80 of
10 router assembly 55 is turned so that the router assembly's
cutting head 67 is directed toward the impinging portions of the
femur which are to be removed, and so that the router assembly's
protective hood 85 is placed between the cutting head and the PCL
so as to protect the PCL from the cutting head. Then shaft 70 is rotated, e.g. with a
power driver (not shown), so as to rotate cutting head 67 and thereby cut away any
15 anatomical structures it comes into contact with.

By turning body 80 circumferentially as required, cutting
head 67 can be used to enlarge femoral notch 20 while keeping the
cutting head from engaging (and thereby cutting) the PCL and/or
other sensitive anatomical structures. In particular, by turning
20 router assembly 55 so that it faces in the manner shown in Figs.
19 and 20, lateral notch structures can be removed. Similarly,
by turning router assembly 55 so that it faces in the manner
shown in Figs. 21 and 22, roof notch structures can be removed.



Significantly, the impinging bone can be removed quickly, easily and safely, without direct visualization of the anatomical structures being trimmed away, due to the use of guidewire 50 and the guidewire-following router assembly 55.

In particular, it is to be appreciated that, by positioning guidewire 50 so that it will extend along the length where the graft ACL will reside, and by properly sizing the radial dimensions of router assembly 55 relative to the graft ACL which will thereafter be installed, the router assembly will clear away only as much bone as is required to properly size the femoral notch and eliminate impingement problems. Furthermore, by properly sizing the longitudinal dimensions of router assembly 55 relative to the notch region where impingement occurs, impingement can be eliminated by just circumferential movement of router assembly 55 on guidewire 50, i.e., without requiring longitudinal movement of router assembly 55 on guidewire 50 during bone-trimming operations.

Significantly, since guidewire 50 is preferably formed out of a highly elastic material, and since the router assembly's shaft portion 70' and body portion 82' are formed so as to be flexible, it is possible to use router assembly 55 to remove impinging bone in a dynamic sense, i.e., to use the router assembly to cut away impinging bone even as the knee is flexed through a full range of natural motions. See, for example, Figs. 19 and 20, where router assembly 55 is shown enlarging the

femoral notch while the patient's leg is bent at approximately a 90° angle; Figs. 21 and 22, where router assembly 55 is shown enlarging the femoral notch while the patient's knee is substantially straight; and Fig. 23, where router assembly 55 is shown enlarging the femoral notch while the patient's knee is bent at approximately a 140° angle. It should be noted in Figs. 21 and 22, and again in Fig. 23, how guidewire 50 and router assembly 55 are capable of undergoing substantial elastic deformation during such knee flexing even as bone-trimming operations are under way.

Looking next at Figs. 24-26, in another preferred embodiment of the present invention, the apparatus of the present invention comprises guidewire 50 and a router assembly 55A.

Router assembly 55A is substantially the same as router assembly 55 described above, except as is shown in the drawings and/or hereinafter described. In particular, router assembly 55A utilizes a collar 83A (Figs. 25 and 26) rather than the collar 83 described above. Collar 83A has its hole 90 disposed off-center within the collar, whereby the router device's cutting head 67 will be clocked to one side relative to the body's hollow outer tube 82 (see Fig. 26). In particular, with router assembly 55A, collar 83A is arranged so that the router device's cutting head 67 is clocked outboard relative to the central axis of hollow outer tube 82. This permits the router device to engage impinging bone more readily. In order to accommodate such

lateral displacement of router device 65, the router assembly's shield 85A has its hole 95A shifted laterally as well, in the manner shown in Fig. 26.

In operation, router assembly 55A is intended to be used in substantially the same way as router assembly 55.

Looking next at Fig. 27, in another preferred embodiment of the present invention, the apparatus of the present invention comprises guidewire 50 and a cannulated router device 65A. Router device 65A is generally similar to the router device 65 discussed above, except that with router device 65A, its cutting teeth 89 are disposed about only a portion of the periphery of its cutting head 67A, with the remainder of the cutting head being smooth and non-abrasive. Accordingly, by moving cannulated router device 65A on guidewire 50 so as to oscillate the router device through only a fraction of a complete revolution, bone can be removed adjacent to the cutting teeth 89 while the remainder (i.e., the non-cutting portion) of the cutting head 67A safely opposes any delicate structures which are to be safeguarded (e.g., the PCL). Thus, with the apparatus of Fig. 27, impinging bone may be safely removed without providing a shield assembly (e.g., such as the shield assembly 75 described above) for the router device.

In another form of the invention, the cannulated router device 65A of Fig. 27 could be replaced with a cannulated router device of the sort adapted to remove hard bone while leaving soft

tissue unharmed. By way of example, the cannulated router device 65A of Fig. 27 might be replaced by the cannulated router device 65B shown in Fig. 28. More particularly, router device 65B includes a cutting head 67B. Alternatively, cutting head 67B could have some other configuration which permits cutting of hard bone without harming soft tissue. As a result of such a construction, a cannulated router device 65B having such a configuration could then be safely rotated completely about guidewire 50 so as to remove impinging bone without risking damage to delicate soft tissue. Thus, with the apparatus of Fig. 28 or with equivalent cutting apparatus, impinging bone can be safely removed without providing a shield assembly (such as the shield assembly 75 described above) for the router device.

The foregoing apparatus may be used in an ACL reconstruction procedure as follows. First, the patient's knee is extended at an angle of approximately 90°. Then a bone tunnel 30 is formed in the tibia. Next, guidewire 50 is passed through bone tunnel 30 and up into the femur. Then a cannulated router device (in the form of either router assembly 55, or router assembly 55A, or router device 65A, or router device 65B) is loaded onto guidewire 50 and used to perform the desired notchplasty in the manner previously described. Next the cannulated router device is dismounted from guidewire 50. Then bone tunnel 35 is formed in femur 10. Then guidewire 50 is removed from femur 10. Finally, a graft ACL 5A is installed in femoral bone tunnel 35 and tibial bone tunnel 30.



Looking next at Fig. 29, in another preferred embodiment of the present invention, the apparatus of the present invention comprises guidewire 50 and a marking device 100. Marking device 5 100 preferably comprises a resilient cannulated head 105 and a flexible cannulated shaft 110 connected to head 105. Cannulated head 105 is formed so that it can hold and release a dye without cutting bone. Marking device 100 is used by moving the device up and down guidewire 50, with or without rotation, whereby the marking head 105 will contact any bone in its way. By sizing 10 marking device 100 properly relative to the size of the graft ACL which is to be installed, movement of marking device 100 along guidewire 50 while the knee is moved through a range of natural motions will cause the marking element to leave its dye on any portions of the femur which might impinge upon the graft ACL which will thereafter be installed in the knee. Thereafter, 15 marking device 100 and guidewire 50 are removed from the surgical site and the surgeon may utilize a conventional cutting element



to remove the marked bone. Then the graft ACL may be installed in the knee without fear of impingement.

In the foregoing description of the preferred embodiments of the invention, it was noted that guidewire 50 is preferably formed out of a pseudoelastic material so as to provide the desired characteristics of firmness and flexibility. However, it should also be appreciated that a guidewire made out of a non-pseudoelastic material can also be utilized in connection with the present invention. Of course, inasmuch as the preferred use of the present invention involves flexing the knee over a wide range of motions with the guidewire in place, limitations in wire flexibility can inhibit the range of knee movements performed with the guidewire in place. Thus, in the situation where a non-pseudoelastic guidewire is to be used, it can be helpful to mount the distal end of the guidewire in a fixture by means of a universal joint. This fixture can then be attached to the bottom surface of the femur or, more advantageously, it can be disposed in a bore formed in the bottom of the femur. Preferably this bore is the femoral bone tunnel 35 used for the ACL reconstruction procedure.

More particularly, and looking now at Fig. 30, the distal end of a non-pseudoelastic guidewire 50A can be mounted in a fixture 115 by a universal joint 120 whereby the proximal end of the guidewire can move about relative to fixture 115. As a result of this construction, when fixture 115 is positioned in

the femoral bone tunnel, universal joint 120 will help guidewire 50A to accommodate the degree of deformation required as the knee is moved through a full range of natural motions. Of course, with this embodiment of the invention, the femoral bone tunnel 35 must be formed before the notchplasty procedure is performed, since fixture 115 is intended to be received in bone tunnel 35.

Modifications Of the Preferred Embodiments

It is to be appreciated that modifications may be made to the preferred embodiments described and illustrated above without departing from the scope of the present invention

Thus, for example, while in the foregoing description the present invention has been described in the context of reconstructing an ACL, it should also be appreciated that the present invention has application to the reconstruction of other ligaments as well, where similar impingement problems can occur. Thus, for example, the present invention might be used in connection with reconstructing the posterior cruciate ligament (PCL).

The present invention can also be used to clear away impinging structures in other anatomical and non-anatomical settings.

Advantages Of The Invention

Numerous advantages are achieved through the use of the present invention.

For one thing, the present invention provides improved apparatus for reconstructing a ligament.

And the present invention provides improved apparatus for reconstructing an anterior cruciate ligament (ACL).

Also, the present invention provides improved apparatus for quickly, easily and reliably eliminating impingement problems when reconstructing an anterior cruciate ligament.

And the present invention provides improved apparatus for quickly, easily and reliably removing any anatomical structures (e.g., bone) which will conflict with the location of a graft ACL at the completion of an ACL reconstruction procedure.

The present invention also provides improved apparatus for quickly, easily and reliably removing any anatomical structures (e.g., bone) which will conflict with the location of a graft ACL as the knee is moved through a full range of natural motions.

The present invention also provides an improved method for reconstructing a ligament.

And the present invention provides an improved method for reconstructing an anterior cruciate ligament (ACL).

And the present invention provides an improved method for quickly, easily and reliably eliminating impingement problems when reconstructing an anterior cruciate ligament.

THE CLAIMS DEFINING THE INVENTION ARE AS FOLLOWS:

1. Apparatus for removing portions of a bone, said apparatus including:

a router assembly including:

5 a cutting head fixed to a shaft; and

a shield assembly having a body portion and a hood portion, said body portion having a hole therethrough for receiving said shaft, said hood portion extending from one end of said body portion and defining a concavity in which is disposable in part said cutting head;

10 and

a guidewire constructed from a highly elastic yet firm material, enabling the router assembly to cut away bone even if the guidewire is flexed relative to the bone.

2. Apparatus according to claim 1, wherein said cutting head and said shaft are provided with bores in alignment with each other and adapted to receive a guidewire therethrough.

3. Apparatus according to claim 2, wherein said hood portion is provided with a hole therein alignable with said cutting head bore and adapted to receive said guidewire.

4. Apparatus according to any one of the preceding claims wherein said body portion is cylindrically shaped and said body portion hole extends lengthwise of said cylindrically shaped body portion and removed from a central axis of said body portion.



32

11. Apparatus according to any one of the preceding claims, wherein at least a portion of said shield assembly is flexible.

12. Apparatus according to any one of the preceding claims, wherein at least a
5 portion of said body portion is flexible.

13. Apparatus according to any one of the preceding claims, wherein said apparatus further includes:

the guidewire, said guidewire being formed out of a pseudoelastic material.

10

14. Apparatus for removing portions of a bone, said apparatus including:
a guidewire; and

a router assembly;

15 said router assembly including a cutting head fixed to a shaft rotatably disposed in a hole through a body portion of a shield assembly, and a hood portion of said shield assembly extending from said body portion of said shield assembly and covering a first portion of said cutting head while leaving exposed a second portion of said cutting head;

20 said guidewire extending through a bore in said shaft, a bore in said cutting head, and a hole in said shield assembly hood portion, such that said router assembly is movable along said guidewire and said shaft is rotatable in said shield assembly body portion, such that said second portion of said cutting head is engageable with the bone and is operative to remove portions of the bone,

wherein said guidewire is constructed from a highly elastic yet firm material, enabling the router assembly to cut away bone even if the guidewire is flexed relative to the bone.

W:\Mary\O\Drawings\Spec\SKLAK.dwg



15. Apparatus for removing portions of a bone, said apparatus comprising a cutting head fixed to a shaft, and a guidewire extendible through a bore extending through said shaft and said cutting head, such that said cutting head is movable
5 along said guidewire, said cutting head being devoid of cutting means on a first portion of the periphery thereof and having cutting means on a second portion of the periphery thereof, said second portion of said cutting head being engageable with the bone portions to be removed, said shaft and cutting head being rotatably
10 movable in an oscillating fashion such that said cutting head second portion moves in alternating opposite directions across the bone portions to remove portions thereof, said first portion being smooth and non-destructive with respect to anatomical structures with which said first portion comes into contact.

16. Apparatus for removing portions of a bone, said apparatus comprising a cutting head fixed to a shaft, and a guidewire extendible through a bore extending
15 through said shaft and said cutting head, such that said cutting head is movable along said guidewire, said cutting head being adapted to cut bone coming into engagement with said cutting head but to leave unharmed soft tissue coming into contact with said cutting head, wherein said guidewire is constructed from a highly
20 elastic yet firm material, enabling the cutting head to cut away bone even if the guidewire is flexed relative to the bone

17. Apparatus for marking portions of bone subsequently to be removed, said apparatus comprising a marker head fixed to a shaft, and a guidewire extendible
25 through a bore extending through said shaft and said marker head, such that said marker head is movable along said guidewire, said marker head being adapted to

W:\My\O'Donnell\Spec\SM\AR.htm



hold a dye and release the dye upon contact with a bone, thereby to mark the portions of the bone proximate said guidewire as said marker head moves along said guidewire.

5 18. Apparatus according to claim 17 further comprising a fixture for disposal in a bone tunnel, with a distal end of said guidewire pivotally attached to said fixture and movable about the pivotal connection such that said guidewire can extend from said fixture at an angle to a lengthwise central axis of said fixture.

10 19. Apparatus for marking bone portions for subsequent removal, the apparatus comprising:

a marker assembly comprising:

a marker head fixed to a shaft and adapted to hold and release a dye;
said shaft and said marker head having bores therethrough;

15 and said apparatus further comprising:

a guidewire for passing through said shaft bore and said marker head bore to support said marker assembly which is movable on said guidewire to engage bone portions proximate said guidewire and mark said bone portions for said subsequent removal.

20

20. A method for removing portions of a bone said method comprising the steps of:

providing (i) a guidewire, and (ii) a router assembly comprising a cutting head fixed to a shaft rotatably disposed in a hole through a body portion of a shield

25 assembly, and a hood portion of said shield assembly extending from said body portion of said shield assembly and covering a first portion of said cutting head

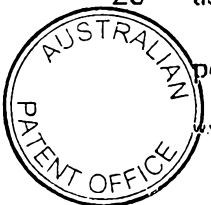

35

while leaving exposed a second portion of said cutting head, said shaft and said cutting head having bores therethrough, and said shield assembly hood portion having a hole therein;

anchoring said guidewire in the bone;

5 mounting said router assembly on said guidewire such that said guidewire extends through said shaft bore, said cutting head bore, and said hood portion hole, and moving said router assembly along said guidewire to proximate the bone;

positioning said router assembly such that said second portion of said cutting head is directed toward the bone portion to be removed, and rotating said shaft, to rotate said cutting head, to remove portions from the bone, while the shield assembly hood portion separates said cutting head from other anatomical structures, wherein said guidewire is constructed from a highly elastic yet firm material, enabling the router assembly to cut away bone even if the guidewire is flexed relative to the bone.

15

21. A method according to claim 20 wherein a distal end of said guidewire is pivotally connected to a fixture and said fixture is anchored in a tunnel in the bone to thereby anchor said guidewire in the bone.

20 22. A method for reconstructing an anterior cruciate ligament (ACL) of a patient using a graft ACL, said method comprising the steps of:

extending the patient's knee at an angle of approximately 90°;

forming a bone tunnel in the patients tibia;

passing a guidewire through said tibial bone tunnel and into the patient's

25 femur, said guidewire being positioned so as to extend along the length where the graft ACL will thereafter reside;



36

positioning a cannulated router device onto said guidewire;

performing notchplasty on said femur using said cannulated router device as said cannulated router device is mounted on said guidewire and as said knee is moved through a range of natural motions; and

5 dismounting said cannulated router device from said guidewire.

23. A method according to claim 22, wherein said method comprises the further steps of:

forming a bone tunnel in said femur;

10 removing said guidewire from said femur; and

installing the graft ACL in said femoral bone tunnel and said tibial bone tunnel.

24. Apparatus for removing portions of a bone substantially as herein described
15 and illustrated with reference to the accompanying drawings.

25. Apparatus for marking portions of a bone subsequently to be removed substantially as herein described and illustrated with reference to the accompanying drawings.

20

26. A method for removing portions of a bone substantially as herein described and illustrated with reference to the accompanying drawings.



37

27. A method for reconstructing an anterior cruciate ligament substantially as herein described and illustrated with reference to the accompanying drawings.

5 DATED: 28 August 2001

PHILLIPS ORMONDE & FITZPATRICK

Attorneys for:

JOSEPH H SKLAR

PHILLIPS
ORMONDE
&
FITZPATRICK
ATTORNEYS
FOR
JOSEPH H
SKLAR



1/20

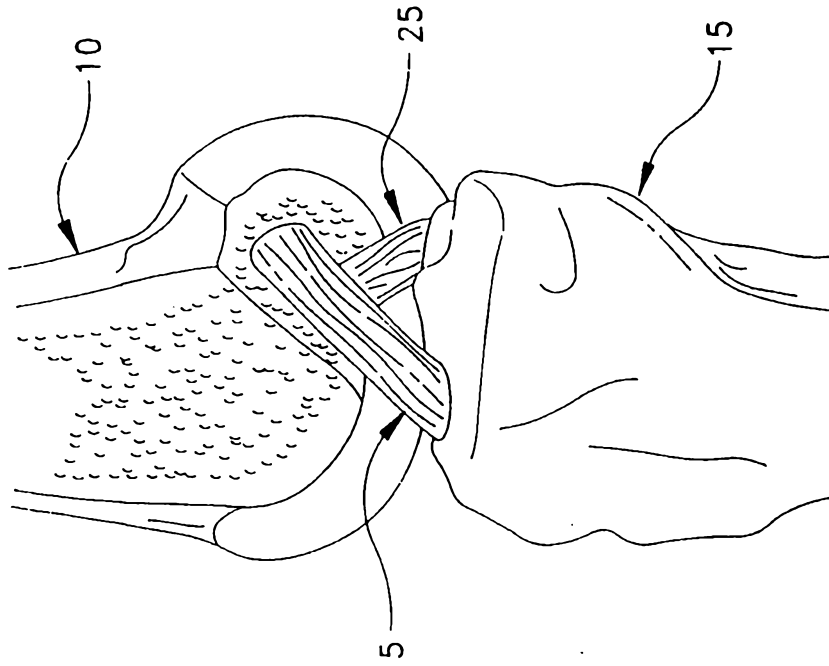

FIG. 2

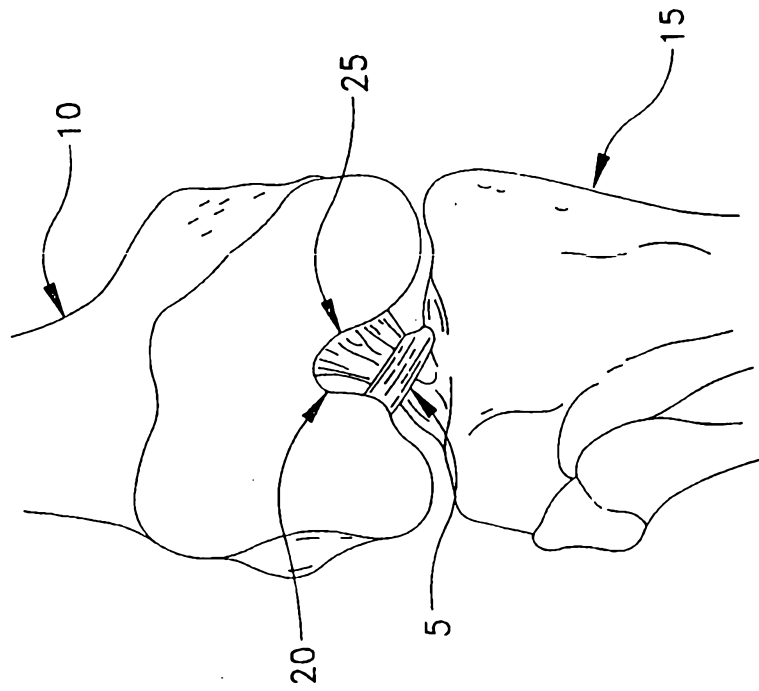

FIG. 1

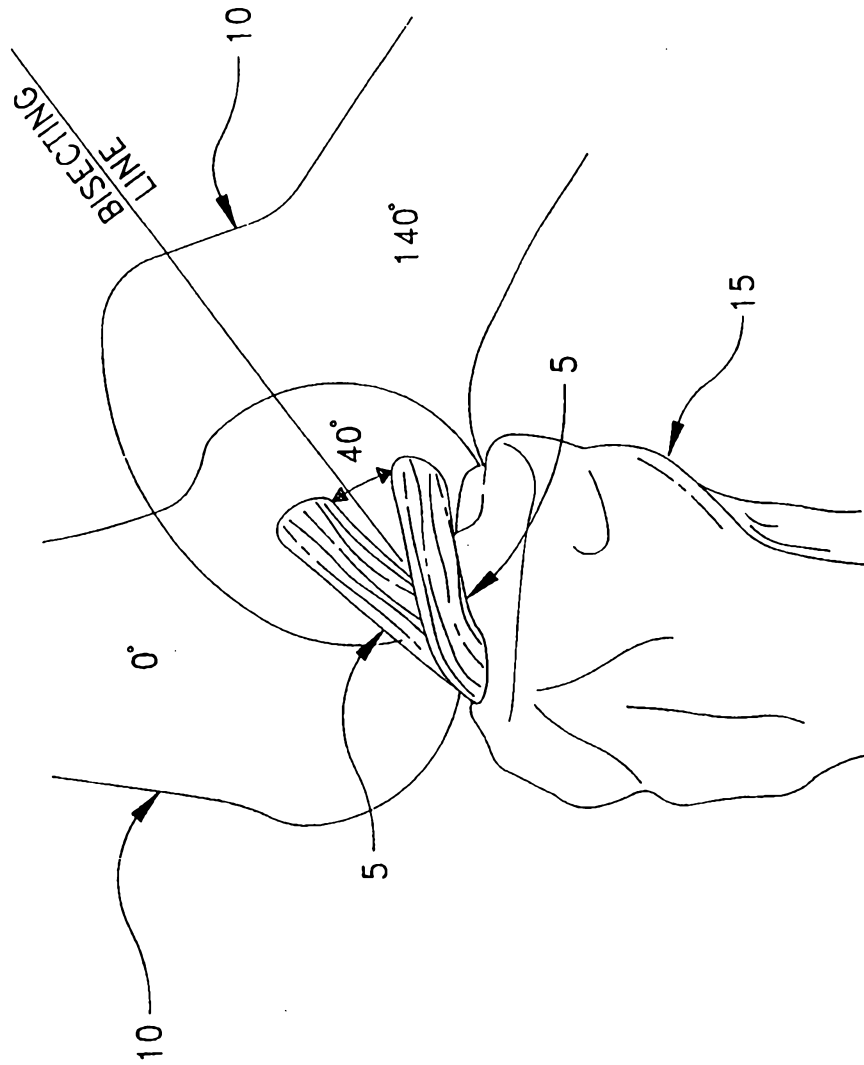

FIG. 3

3/20

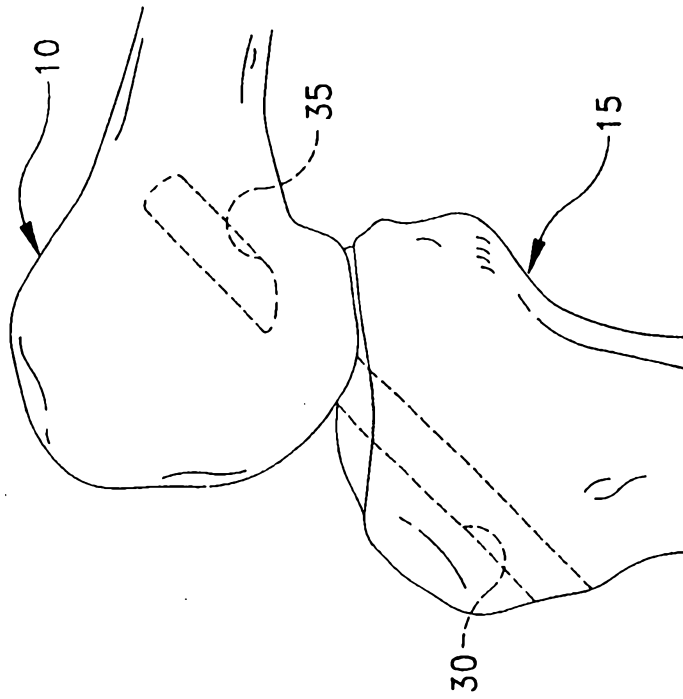

FIG. 5

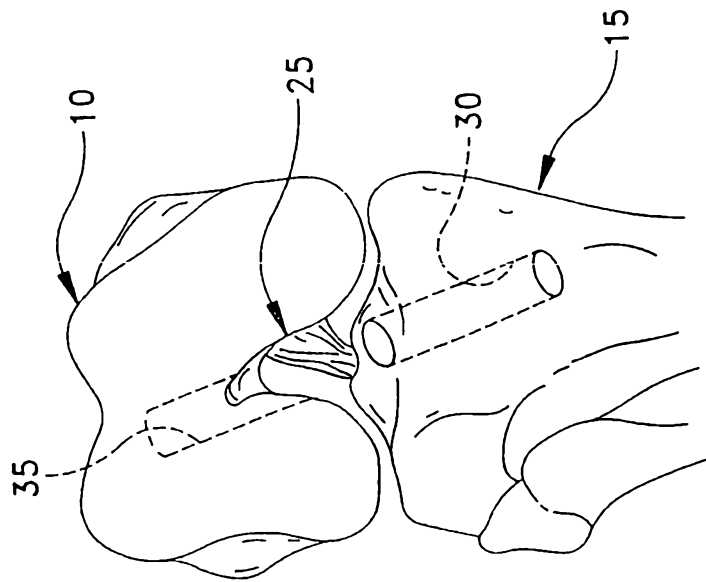

FIG. 4

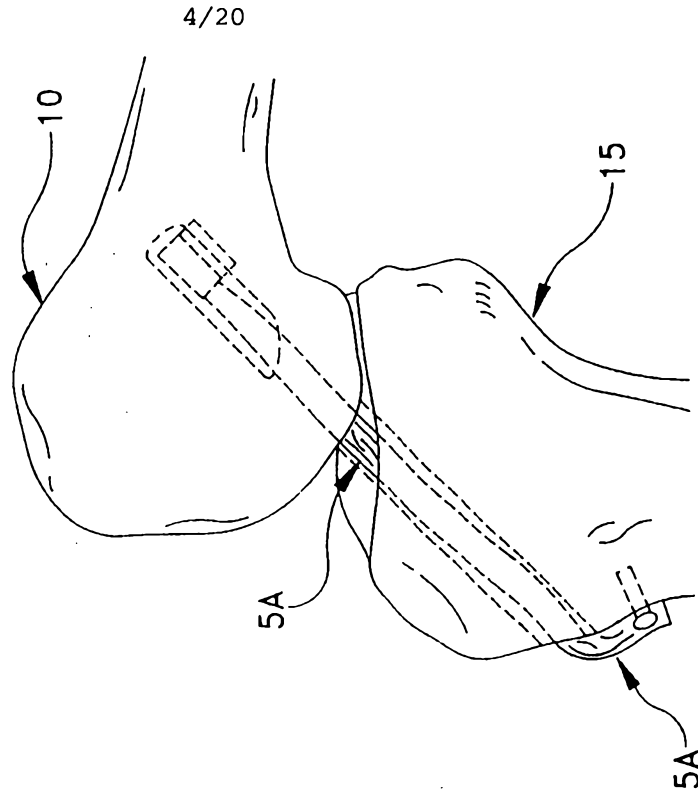

FIG. 7

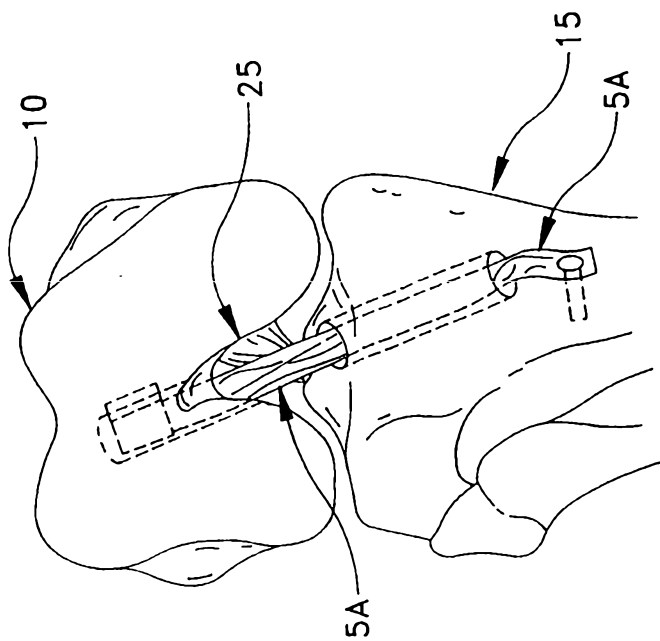

FIG. 6

5/20

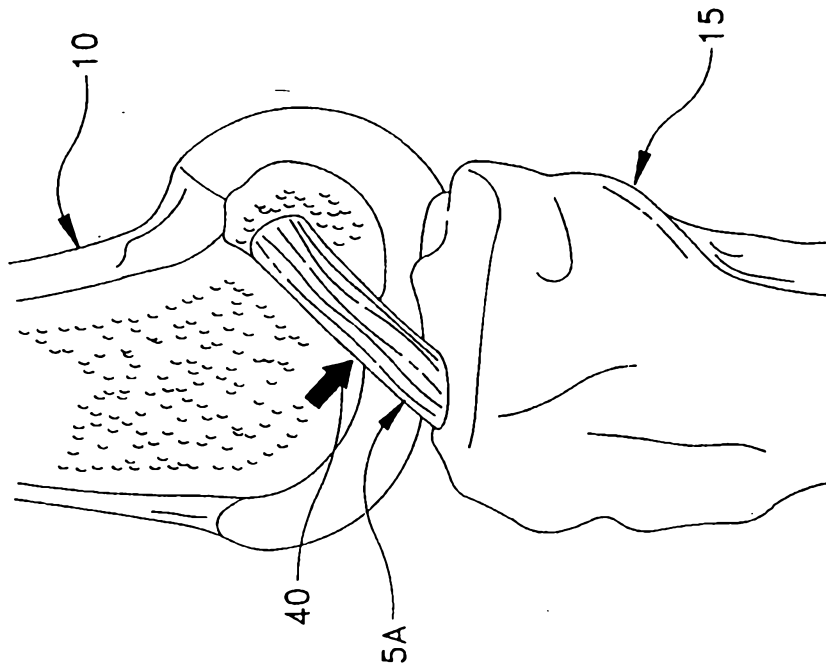

FIG. 9

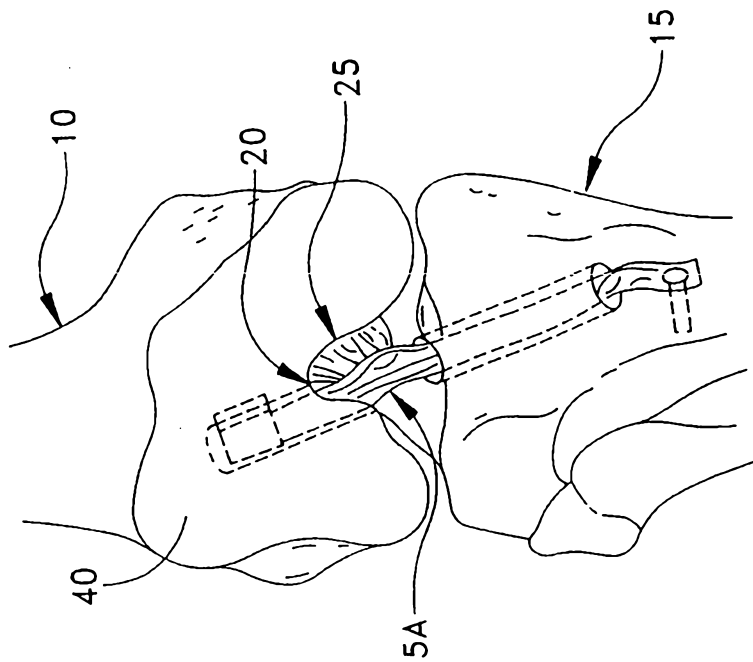

FIG. 8

6/20

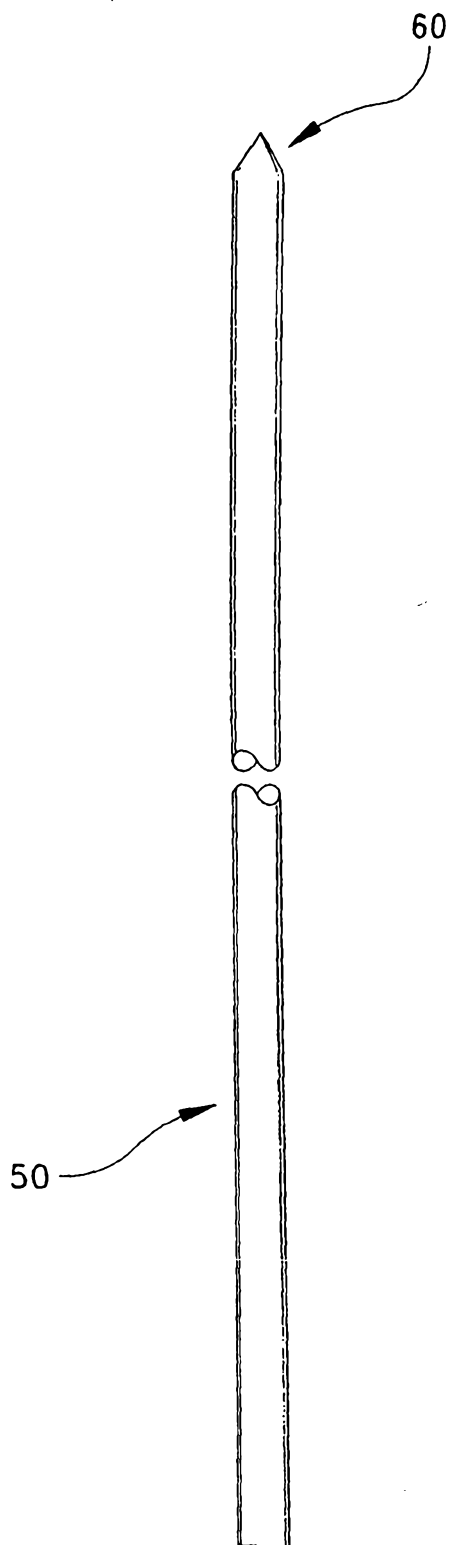

FIG. 10

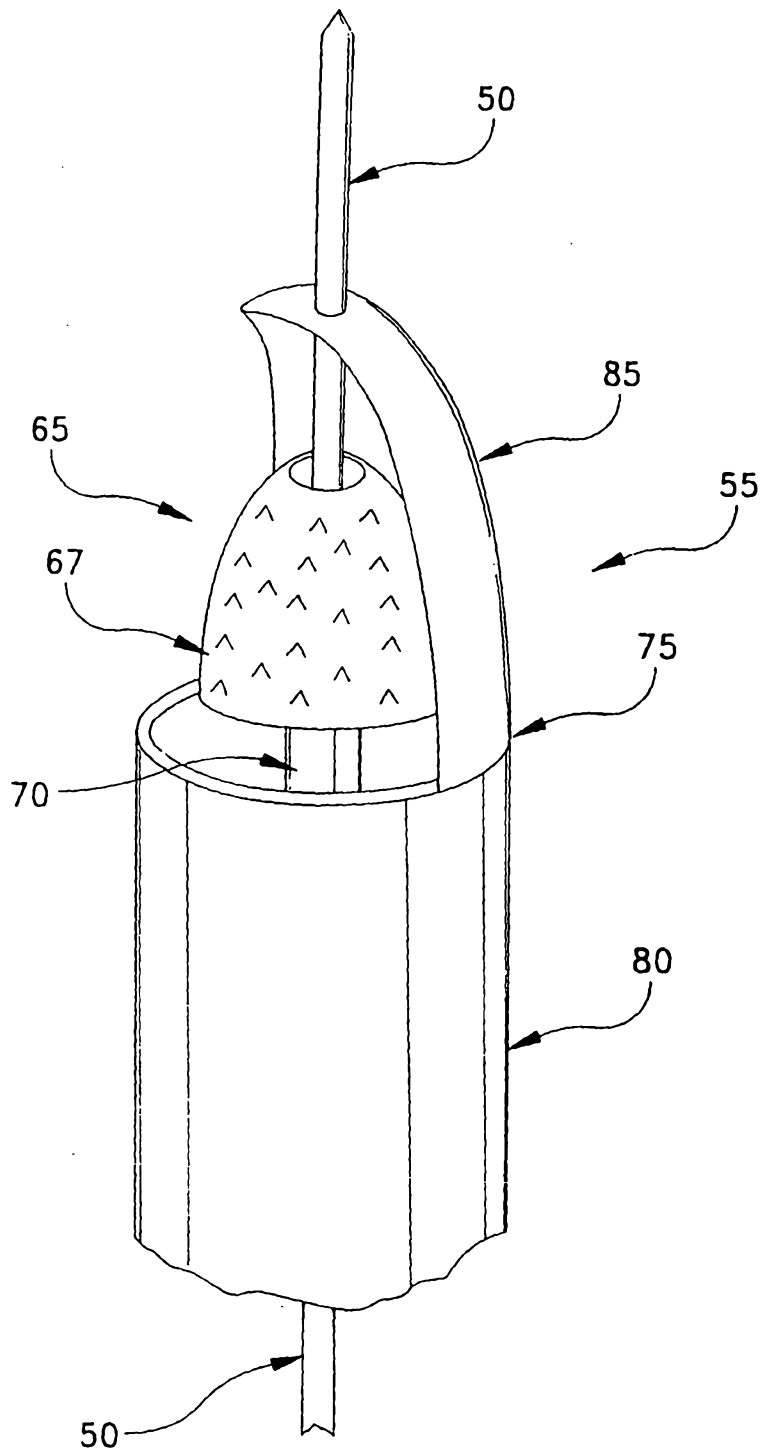

FIG. 11

8/20

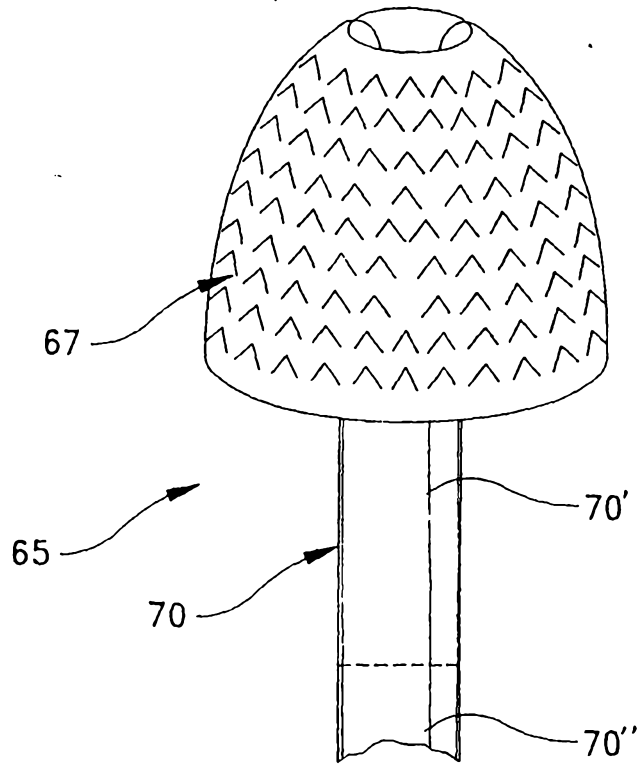

FIG. 12

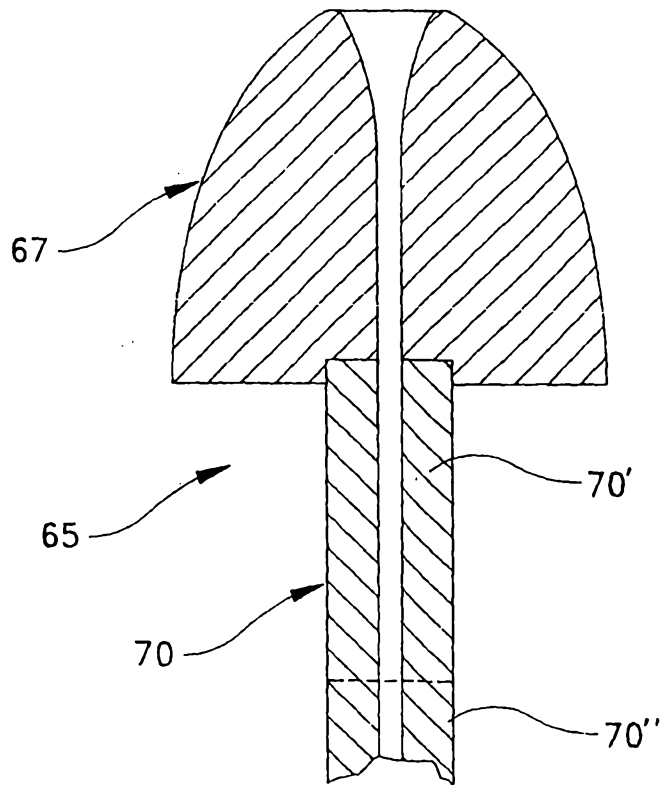
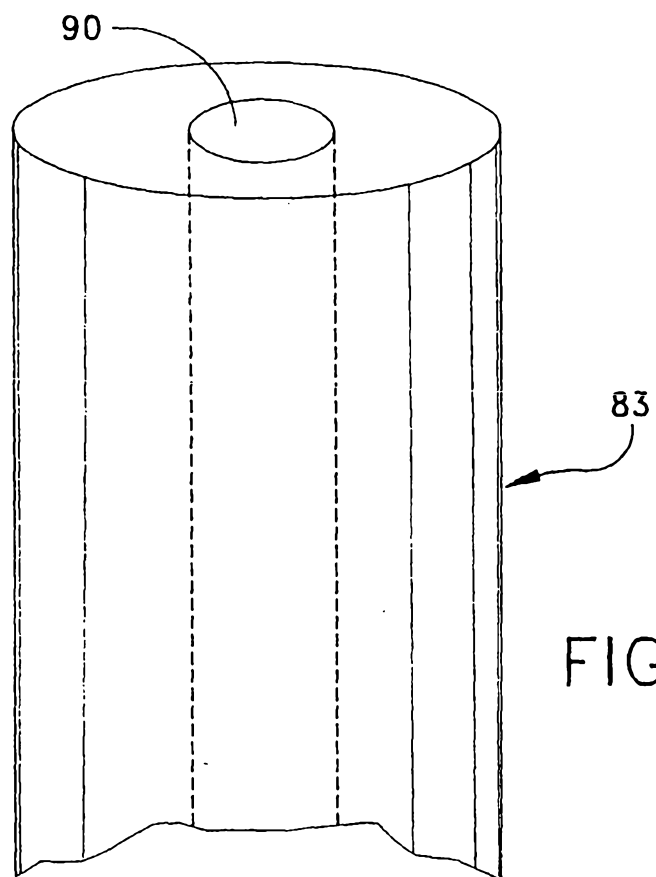
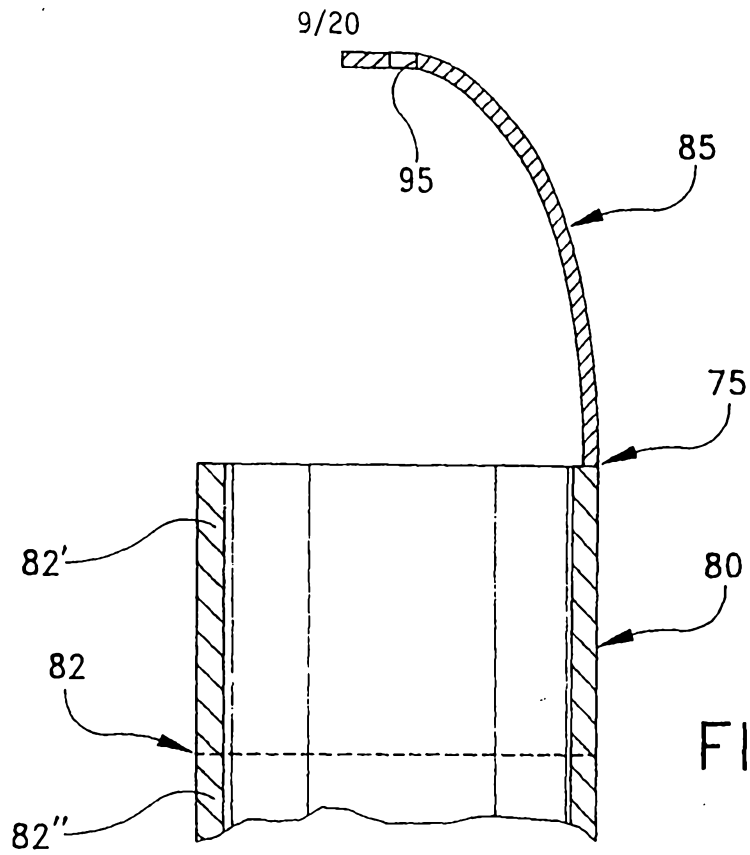

FIG. 13



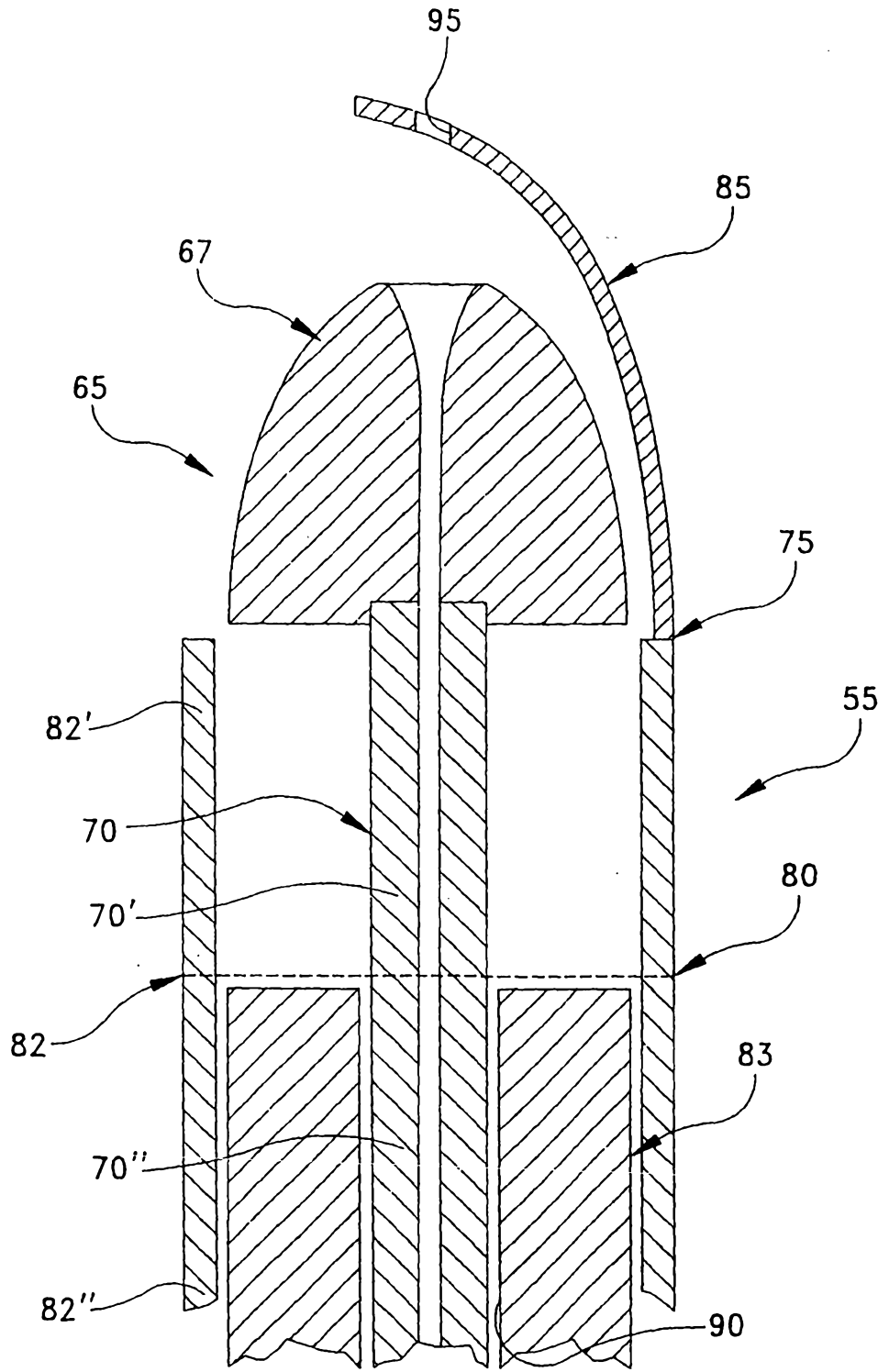

FIG. 16

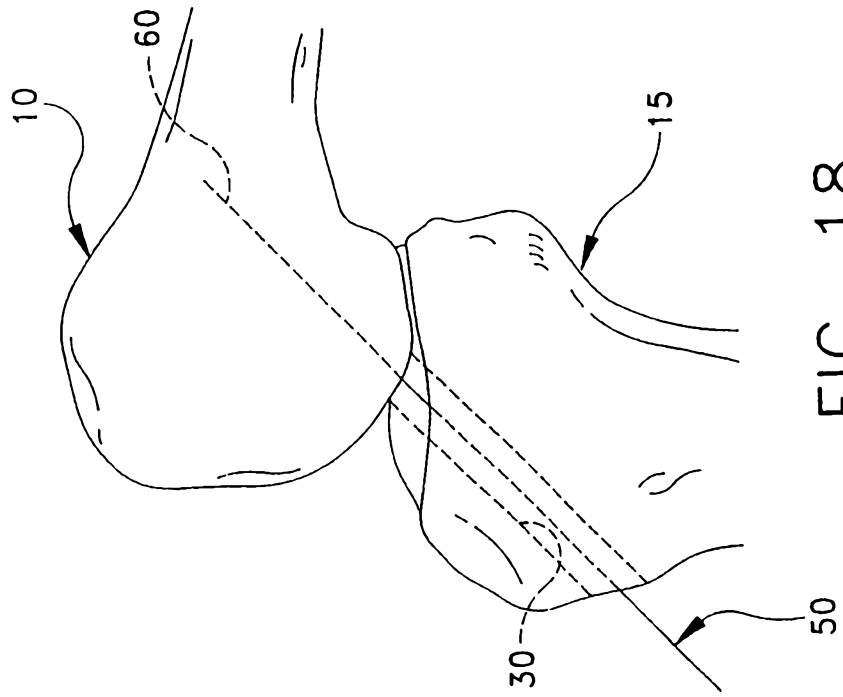

FIG. 18

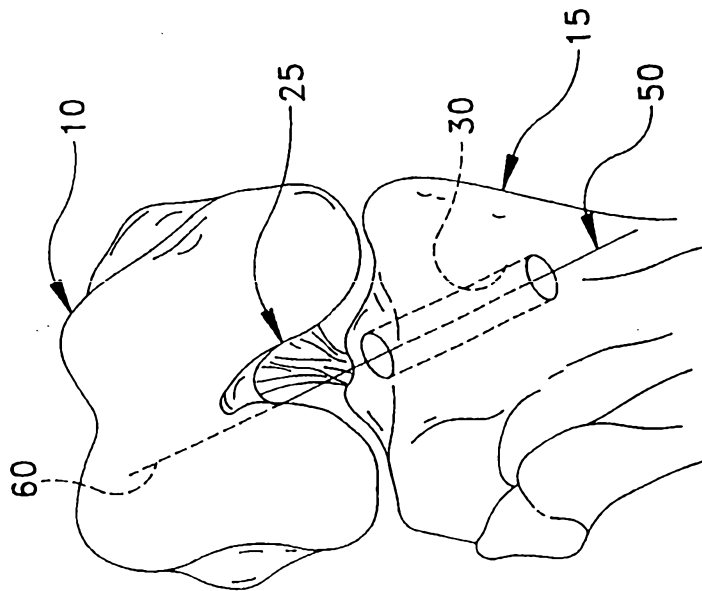

FIG. 17

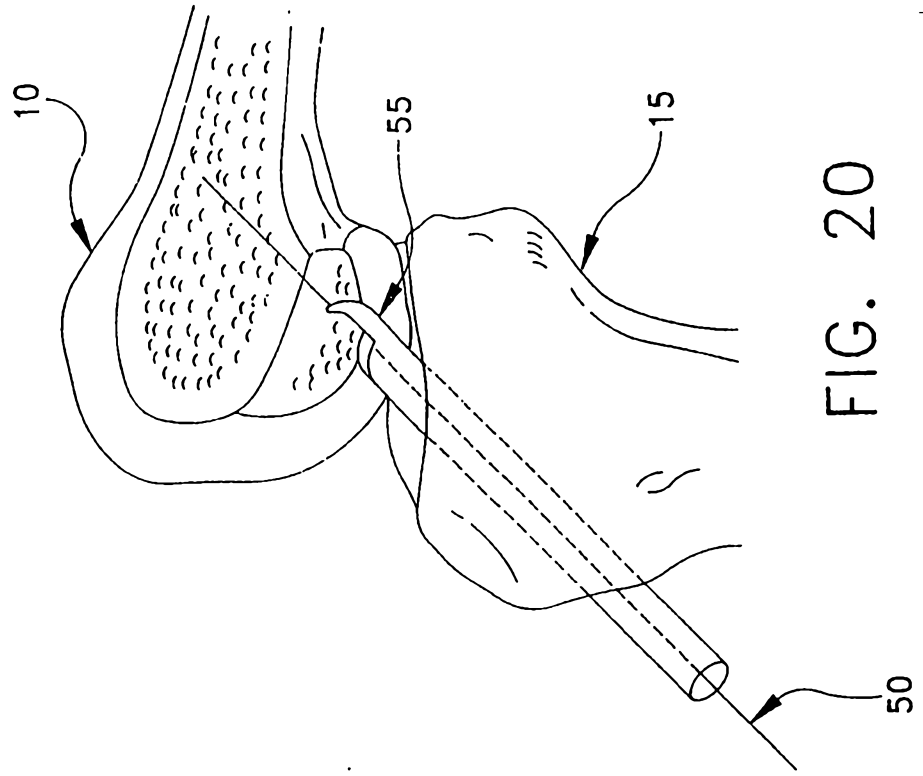

FIG. 20

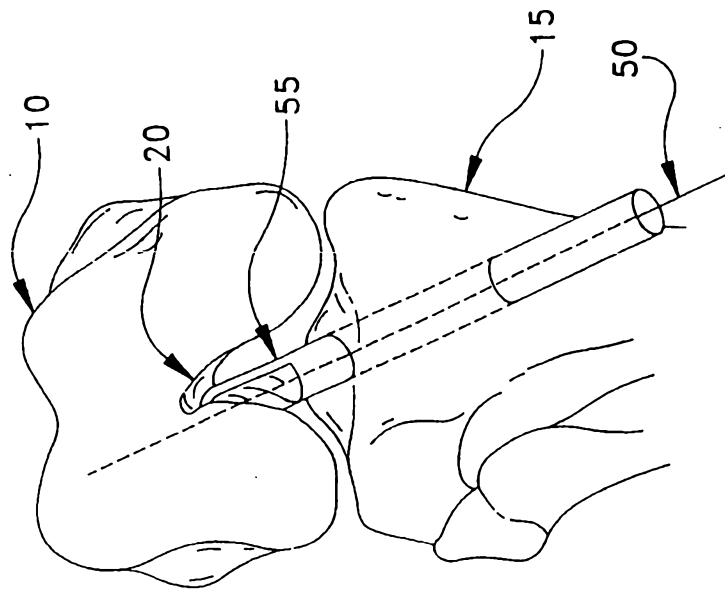

FIG. 19

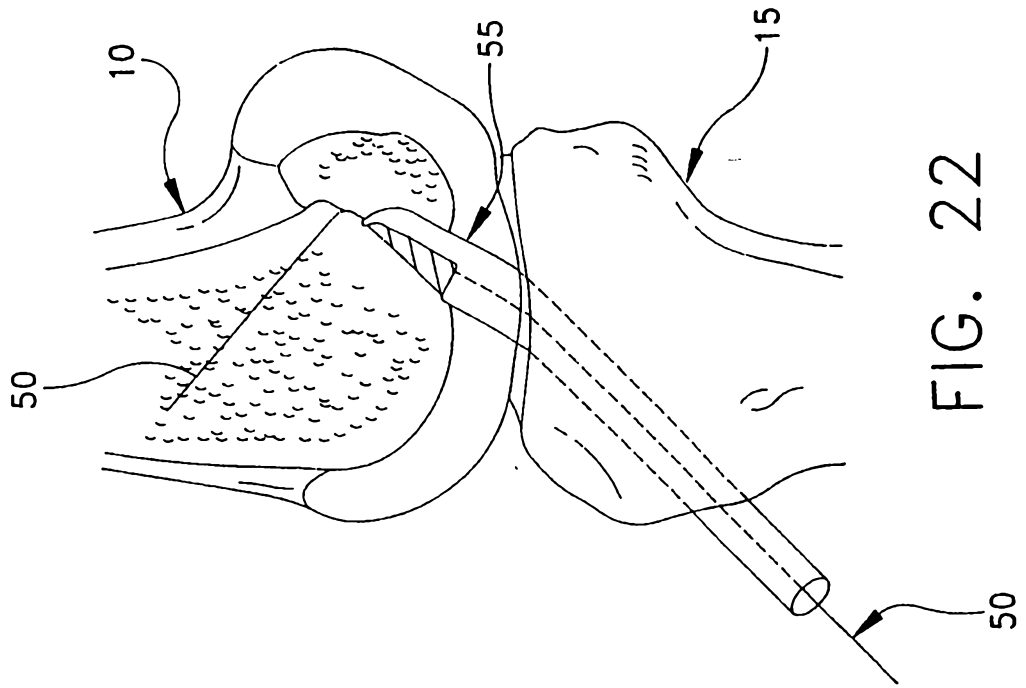

FIG. 22

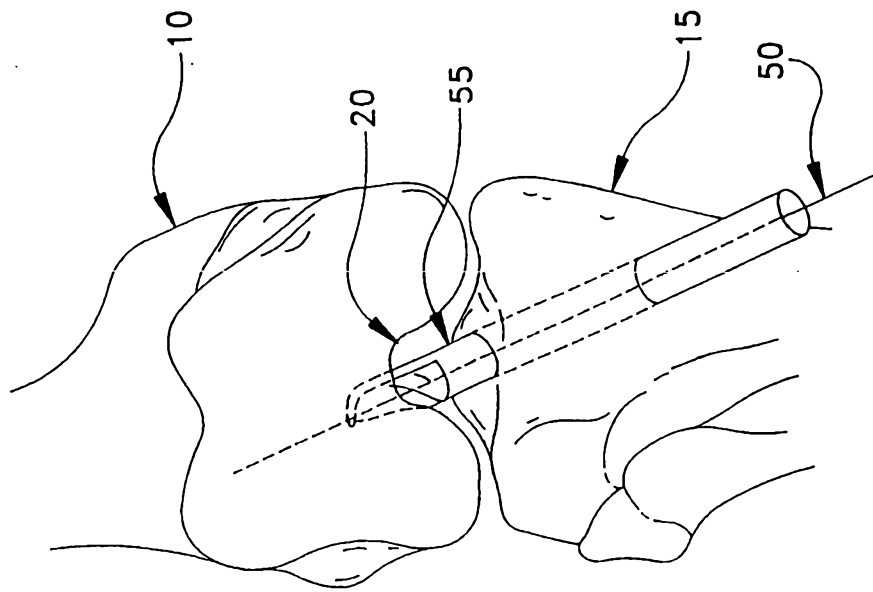

FIG. 21

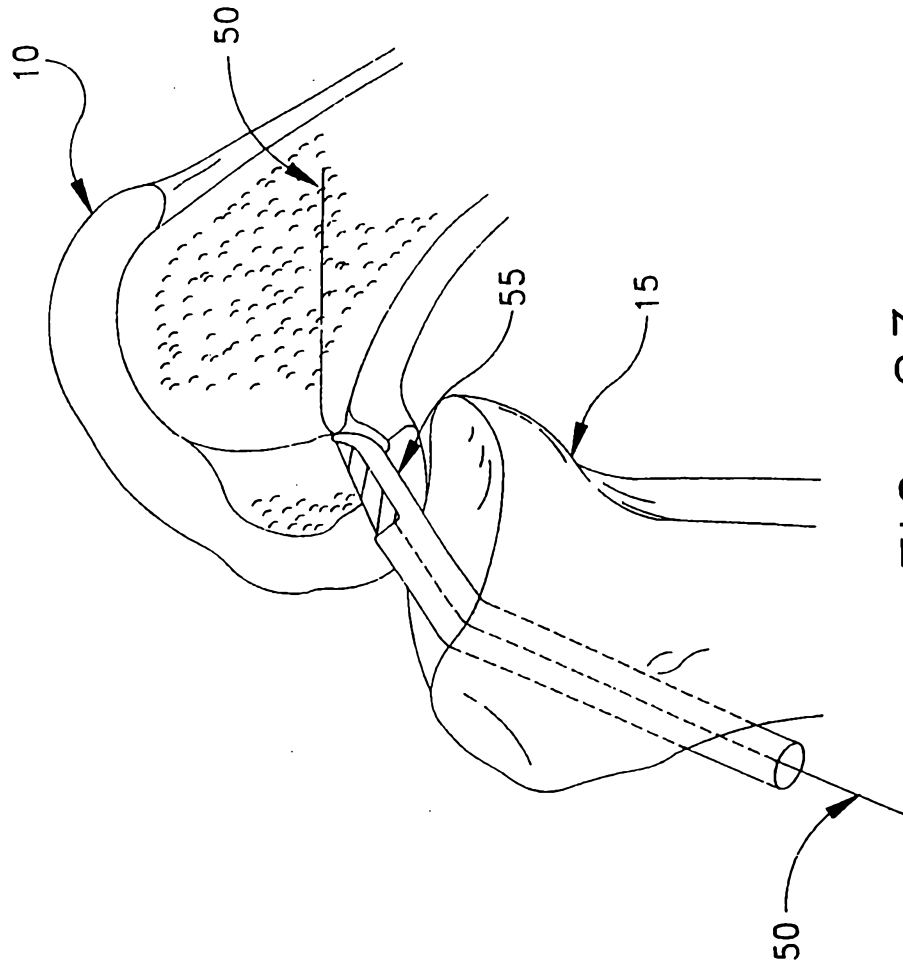

FIG. 23

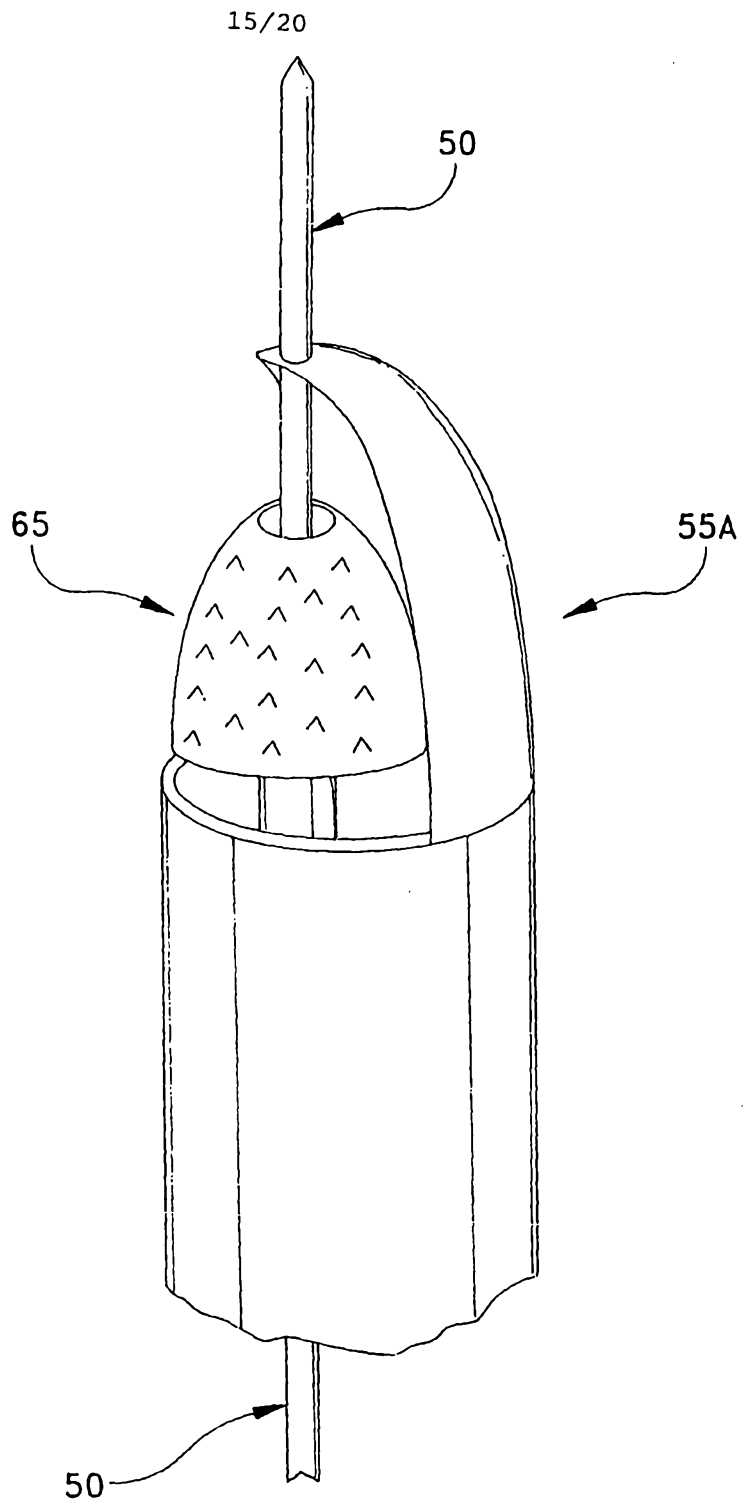

FIG. 24

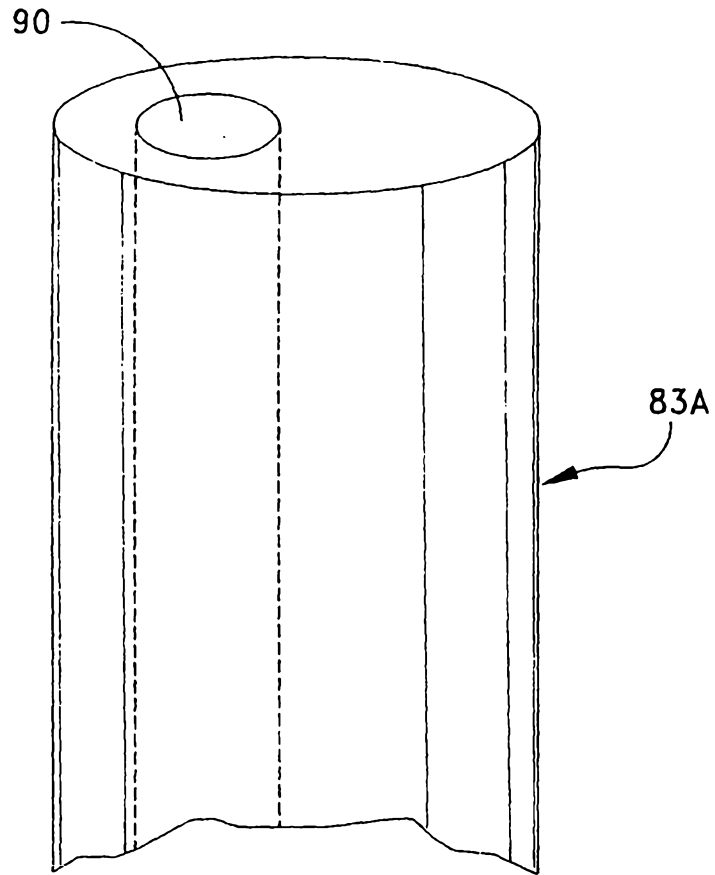

FIG. 25

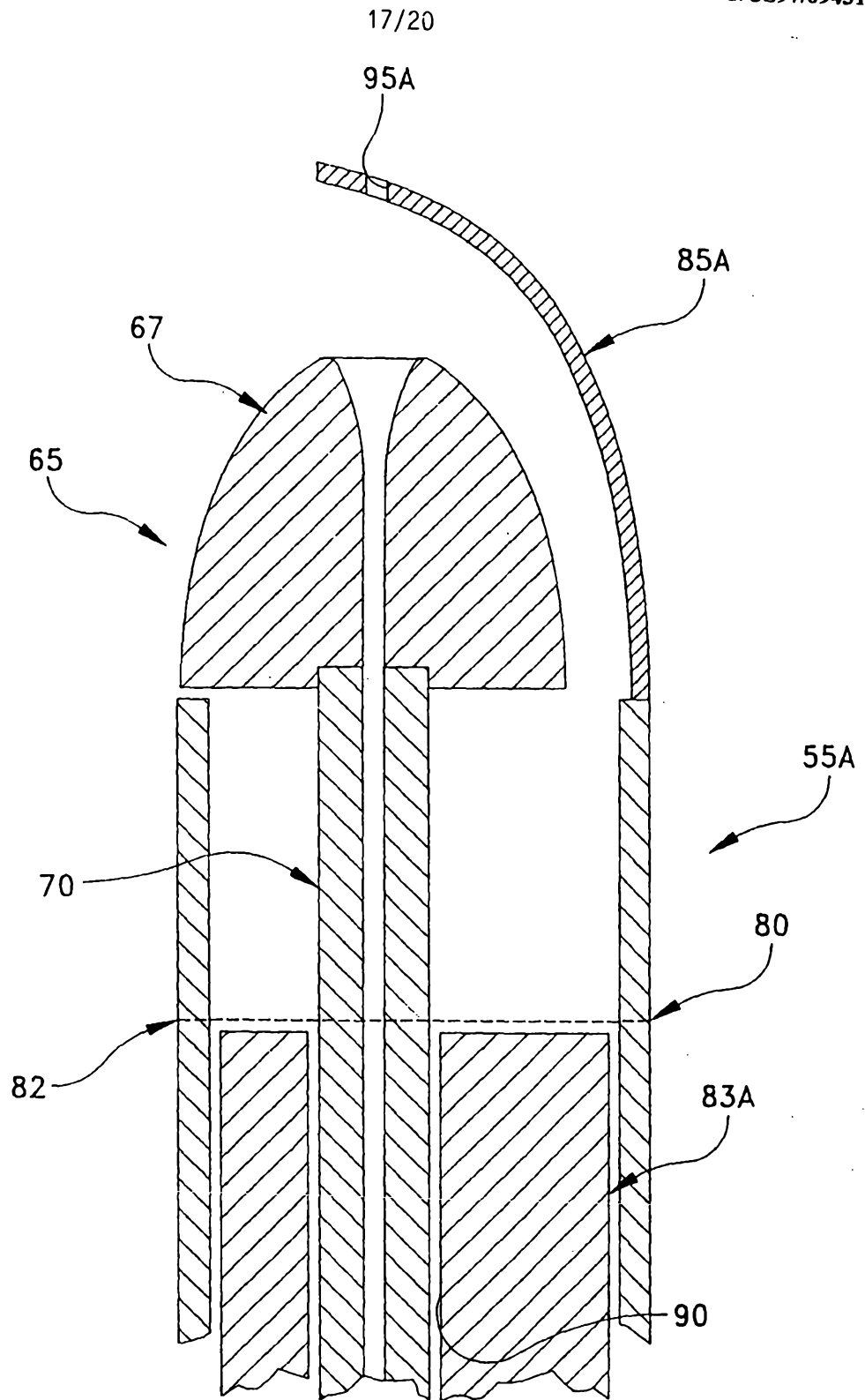

FIG. 26

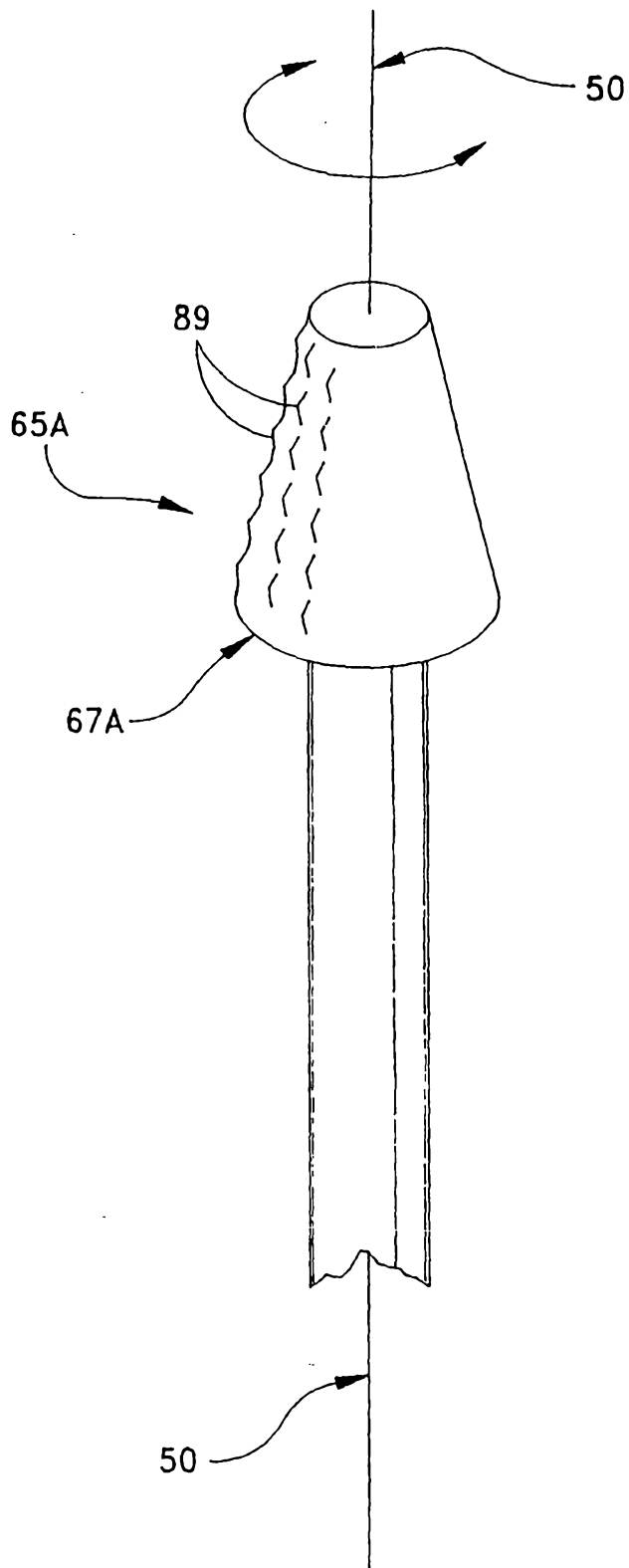

FIG. 27

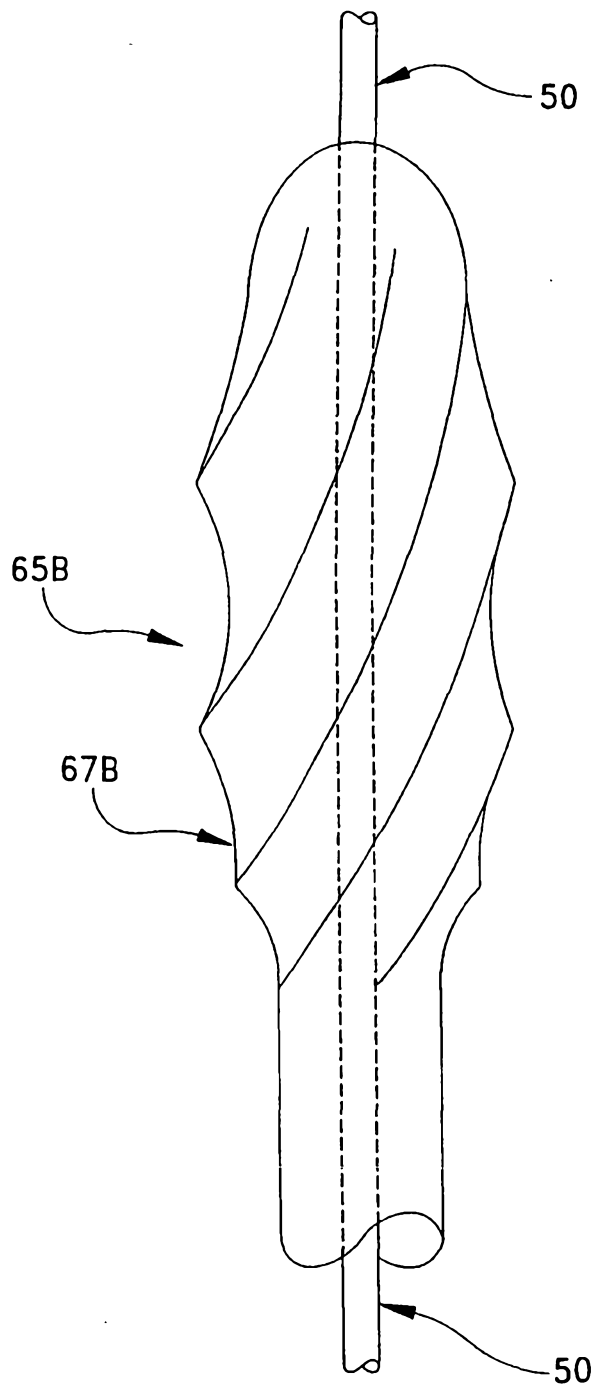

FIG. 28

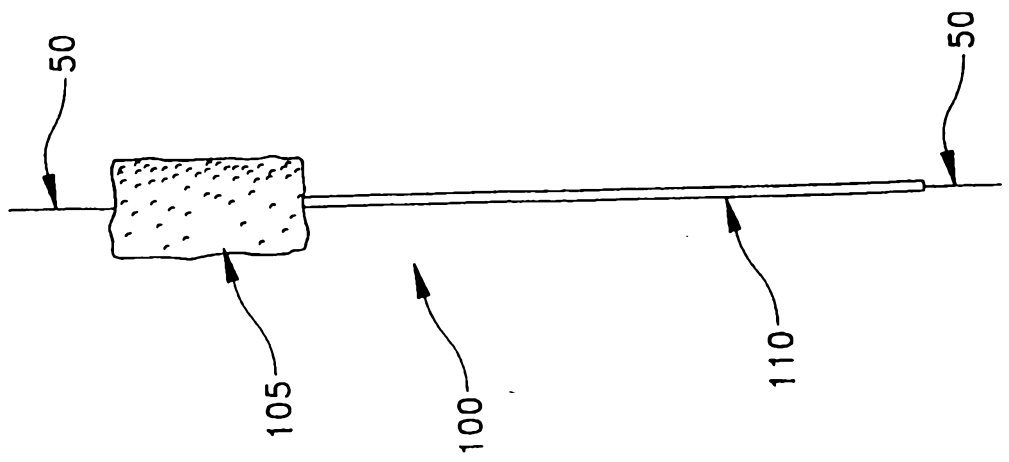

FIG. 29

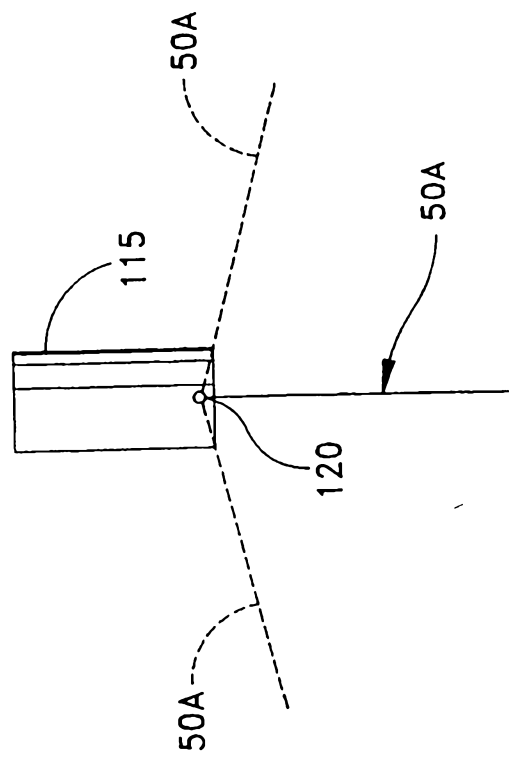

FIG. 30