

Oct. 4, 1938.

H. C. SCHILLING

2,132,131

BED

Filed Aug. 5, 1936

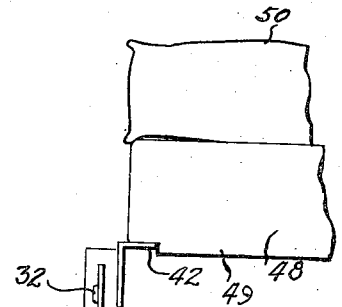
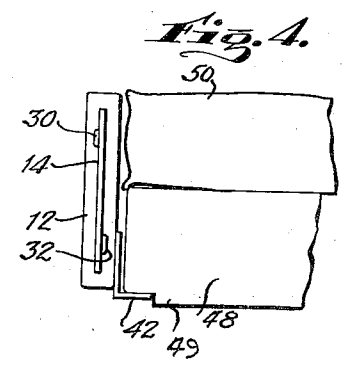
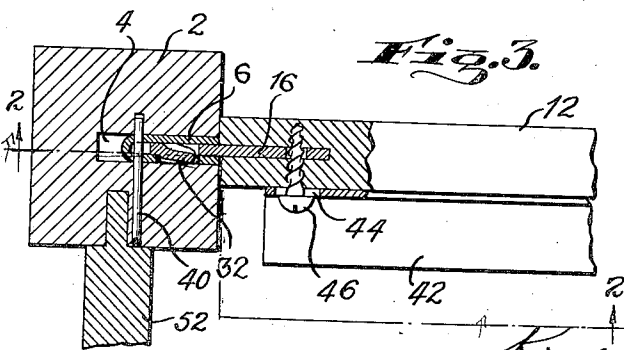
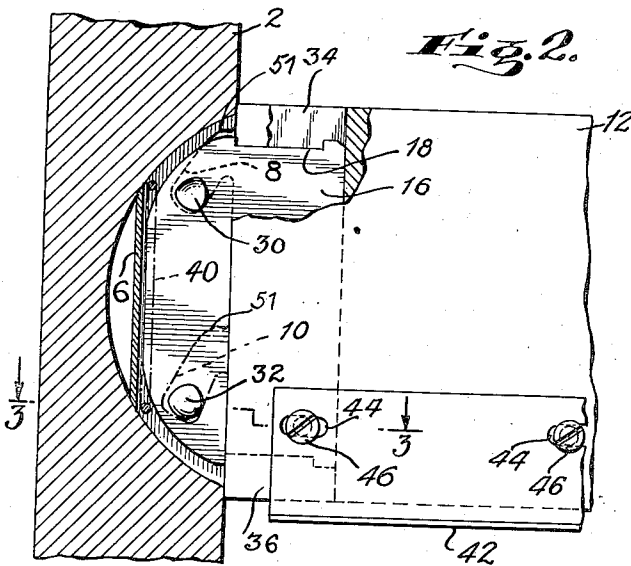
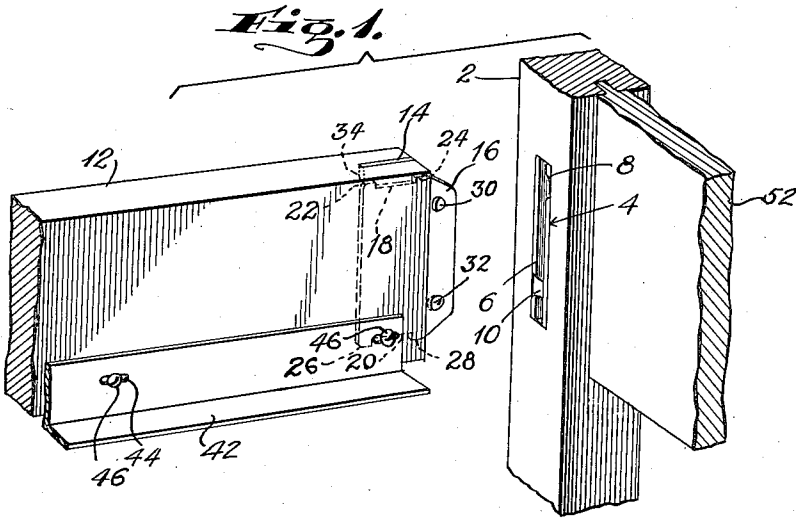

INVENTOR
HENRY C. SCHILLING
BY
Kidd, Bethell & Montgomery
ATTORNEYS

UNITED STATES PATENT OFFICE

2,132,131

BED

Henry C. Schilling, New York, N. Y.

Application August 5, 1936, Serial No. 94,322

1 Claim. (Cl. 5—294)

This invention relates to improvements in beds and is particularly directed to an improved demountable connection between the side rails and the corner posts and also a novel means for supporting the bed spring and mattress thereon.

In the construction of wooden beds at the present time studs are driven into the corner posts for receiving a metal plate attached to the side rails which is provided with slots to be engaged by the studs. In such constructions the studs wear the wooden uprights so that the holes in which the studs are inserted become enlarged resulting in a structure which is no longer rigid, also the metal plates carried by the side rails wear away the slot formed in the upright for the reception of said plates which further results in rendering the structure unsteady.

One of the objects of the present invention is to provide a structure wherein the side rails will always be rigidly and securely held in the uprights or corner posts of the bed.

Another object of the invention is the provision of a structure of the character indicated wherein wearing away of the wooden upright is entirely eliminated.

Another object of the present invention resides in the provision of means for preventing the warping or cupping of the side rails of the bed structure.

A further object of the present invention resides in a structure wherein side rails of smaller cross section than is possible in structures of the present time may be employed.

A further object of the present invention is the provision of a device wherein no crevices are left at the juncture of the side rails and corner posts wherein vermin may breed.

A still further object of the invention resides in the provision of a structure of the character indicated which will permit of inverting the side rails to raise or lower the sleeping level, as desired, and wherein the mattress or spring will not mar or scratch the side rails.

Further objects of my invention will be manifested from the following description and the accompanying drawing, in which drawing:

Fig. 1 is a perspective view of part of a side rail and corner post showing my improved connection;

Fig. 2 is a sectional view taken on line 2—2 of Fig. 3 showing a corner post and side rail in place;

Fig. 3 is a view taken on line 3—3 of Fig. 2;

Fig. 4 is a view showing the device supporting a spring and mattress at the low or normal level;

Fig. 5 is a similar view showing the device supporting a spring and mattress at a higher level.

Referring to the drawing in detail: 2 designates a corner post provided with a vertically extending slot 4 adapted to receive a metal member 6. The member 6 comprises a sheet of metal bent to form a U in cross section and provided with an inwardly and downwardly extending slot 8 on one side or wall and an inwardly and downwardly projecting slot 10 in the other wall.

The numeral 12 designates a side rail, provided with a vertical slot 14 into which is inserted a metal plate 16. This plate is provided with a cut-out 18 at its upper end and a similar cut-out 20 at its lower end, these cut-outs providing projections 22 and 24 at the upper end and projections 26 and 28 at its lower end. The portion of the plate 16 which constitutes the male member of the connection is provided with protuberances or projections 30 and 32, the protuberance 30 being struck up on one side of the plate and the protuberance 32 being struck up on the other side, so that the protuberance or projection 30 will engage the slot 8 of the female member 6 and the protuberance or projection 32 will engage the slot 10 of the female member when the parts are assembled.

Filler pieces 34 and 36 of wood or other suitable material may be inserted in the slot 14 so as to rest in the slots 18 and 20 of the plate 16 to assist in holding the plate in place in the side rail 12.

As will be seen from Fig. 2, when the parts are assembled the projections 30 and 32 are in the bottom of the slots 8 and 10, respectively, of the female member 6 and when the parts are in this position it will be noted that the edges of the side rail completely close the slot 4 so that there is no space between the side rail and post and the slot 4 formed in the female member is closed so that there is no place for vermin to breed or accumulate.

As will be seen from Fig. 2 the female member 6 is held in the slot 4 by means of a U-shaped pin or bar 40 which is inserted through the post 2 and member 6.

The plate 16 will serve also to prevent cupping of the side rail as will be obvious. I provide an angle-iron 42 which has slots 44 adapted to receive screws 46 for securing the same to the side rail. The slots are provided to compensate for any elongation or shrinkage of the side rail 12. The screw 46 adjacent the plate 16, it will be noted, enters the slot 20 of the plate and further assists in holding the plate 16 in place in the side

rail 12. It will be appreciated that this angle-iron will prevent warping of the side rails.

It will be noted that the angle-iron 42 projects slightly below the lower edge of the side rail 12, as will be clearly seen in Fig. 4. The lower flange of the angle-iron 42 is adapted to support box spring 48 having the usual rabbet or flange 49. This spring in turn supports a mattress 50.

As illustrated in Fig. 4 the angle-iron 42 supports the spring and mattress at normal sleeping level. If, however, it is desired to raise the sleeping level the side rail 12 is removed from the position shown in Fig. 4, inverted and turned end for end so that the angle-iron 42 is then at the upper edge of the rail 12, as illustrated in Fig. 5.

It will be noted that when the side rail is in either the position illustrated in Fig. 4 or the position illustrated in Fig. 5 that the projections 30 and 32 are in position to be received by the inwardly and downwardly extending slots 8 and 10 of the female member 6.

It will also be noted from Fig. 5 that the spring 48 rests directly on the angle-iron 42 which extends slightly above the side rail 12 whereby the spring will not rest upon, mar or scratch the side rail 12.

It will be appreciated that with my improved invention, side rails smaller in cross section than heretofore used may be employed due to the reinforcing of the rails by the member 16 and the angle-iron 42.

In order to prevent accidental disconnection of the side rails from the corner posts it will be noted from Fig. 2 that I have provided a slight indentation or curvature 51 in each of the slots 8 and 10

of the member 6. Should the side rail be accidentally raised the projections 30 and 32 of the member 16 will be prevented from disengaging the slots by these indentations as will be obvious.

The end rails 52 may be secured to the corner posts in the usual manner but if desired it will be appreciated that they may also be secured to corner posts by the members 16 and 6, respectively, of my invention.

It will be appreciated that any type of bed spring structure may be employed with my improved device. Other type springs will be provided with similar projections or flanges. It will also be appreciated that instead of having the spring rest directly on the angle-irons that the usual slats may be supported on these angle-irons for supporting the spring.

It is to be understood that various changes and modifications may be made in the structure herein illustrated and described without departing from the spirit and scope of my invention.

What I claim is:—

A bed comprising a corner post and a side rail, the side rail being provided with a vertical slot at the end thereof, a plate projecting from said slot, a lateral projection on each face of said plate, said corner post being provided with a vertical slot, a metal U-shaped member in said slot adapted to receive said plate, said U-shaped member being provided with an inwardly and downwardly projecting cut-out portion at different levels in each wall thereof adapted to receive the projections on said plate, thereby to rigidly secure said side rail to said corner plate.

HENRY C. SCHILLING. 35