

No. 696,338.

Patented Mar. 25, 1902.

T. W. HULLINGER.  
PUMPING JACK.

(Application filed June 27, 1901.)

(No Model.)

2 Sheets—Sheet 1.

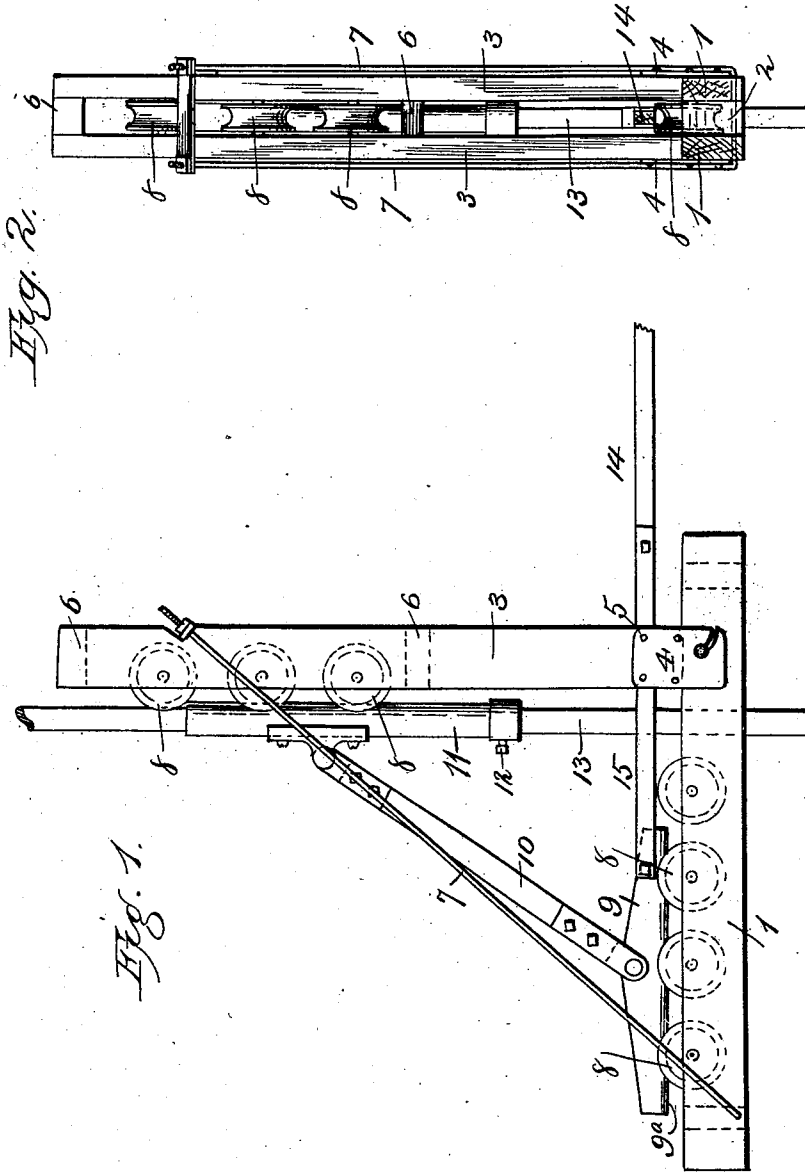

Witnesses  
F. L. Curran  
Frank G. Radelfinger

Inventor  
Thomas W. Hullinger  
by Louis Rager & Co.,  
Attorneys.

No. 696,338.

Patented Mar. 25, 1902.

T. W. HULLINGER.  
PUMPING JACK.

(Application filed June 27, 1901.)

(No Model.)

2 Sheets—Sheet 2.

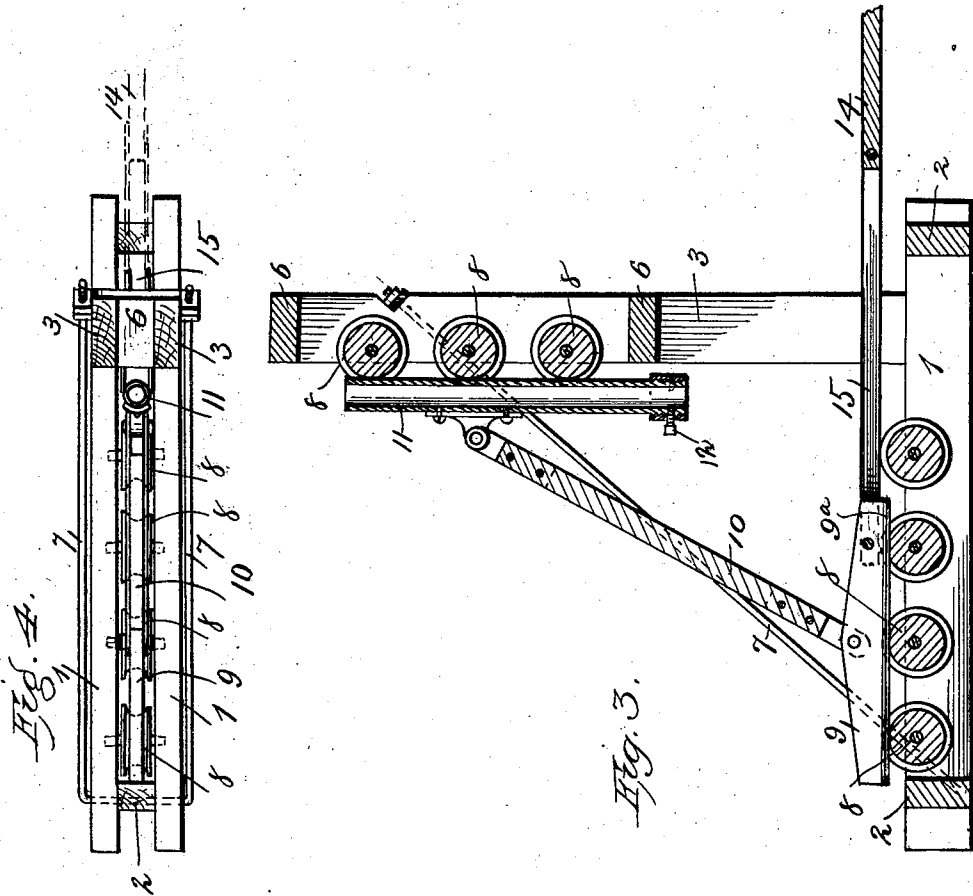

Witnesses  
F. L. Curand  
Frank G. Radelfinger.

Inventor:  
Thomas W. Hullinger,  
by Louis Ragger & Co.,  
Attorneys

# UNITED STATES PATENT OFFICE.

THOMAS W. HULLINGER, OF LIMA, OHIO.

## PUMPING-JACK.

SPECIFICATION forming part of Letters Patent No. 696,338, dated March 25, 1902.

Application filed June 27, 1901. Serial No. 66,248. (No model.)

*To all whom it may concern:*

Be it known that I, THOMAS W. HULLINGER, a citizen of the United States, residing at Lima, in the county of Allen and State of Ohio, have invented new and useful Improvements in Pumping-Jacks, of which the following is a specification.

My invention relates to pumping-jacks of the type used to operate oil-wells situated at some distance from the power-station.

The object of my invention is to construct a jack having the several advantages of simplicity and rigidity in construction and ease and efficiency in operation for use in all kinds of wells.

My novel construction is fully described in this specification and claimed, and illustrated in the accompanying drawings, forming a part thereof, in which—

Figure 1 is a side elevation of my device. Fig. 2 is a rear elevation of the same. Fig. 3 is a vertical section of the same. Fig. 4 is a plan view of the same.

Like numerals of reference designate like parts in the different views of the drawings.

The numeral 1 designates the horizontal members of the frame for supporting the working parts of my device. There are two members 1, extending parallel to each other and tied together by spacing-blocks 2. Footed on the horizontal members 1 are vertical members 3, secured thereto by plates 4 and bolts 5. The vertical members 3 are also parallel and are tied together by blocks 6. To secure the frame together, diagonal brace-rods 7 are employed.

Journalled in the horizontal and vertical members 1 and 3 are sheaves 8, which sheaves form roller-bearings for the moving parts or rack of the jack. The rack comprises a horizontal bar 9, which is pivoted to a connecting-rod 10, oppositely pivoted to a sliding head 11. The bar 9 is rounded off on the under side at 9<sup>a</sup> to adapt it to run on the sheaves 8. The head 11 is hollow and runs on the sheaves

8, supported by the members 3. Set-screws 12, seated in the head, serve to clamp a pump-rod 13, extending up and through the head 11. By this arrangement the head 11 may be adjusted and set at different points in the rod 13 and the stroke regulated.

My jack is connected to the power-station by a pitman 14, which is pivoted to the horizontal bar 9 and is bifurcated at 15 to straddle the pump-rod 13.

In operation the pitman 14 is driven by an engine, and the movement is communicated to the pump-rod 13 through the medium of the bar 9, connecting-rod 10, and head 11. The sheaves 8 form guides, as well as bearings, and hold the bar 9 and head 11 in line, thereby keeping the jack true and free from wobbling.

I do not wish to be limited as to details of construction, as these may be modified in many particulars without departing from the spirit of my invention.

Having thus described my invention, what I claim as new, and wish to secure by Letters Patent, is—

1. In a device of the class described, the combination with a framework having horizontal and vertical members, sheaves journalled in said frame, a horizontal bar mounted to run on said sheaves, a vertical head mounted to run on said sheaves, and a connecting-rod pivoted to said head and said horizontal bar, substantially as described.

2. In a device of the class described, the combination of a horizontal bar, a vertical head, a connecting-rod pivoted to said bar and said head, and roller-bearings for said bar and said head, substantially as described.

In testimony whereof I have hereunto set my hand in presence of two subscribing witnesses.

THOMAS W. HULLINGER.

Witnesses:

ELVIN R. HULLINGER,  
WILLIAM E. REILLY.