

19



**Octrooi centrum
Nederland**

11

2018380

12 B1 OCTROOI

21

Aanvraagnummer: **2018380**

51

Int. Cl.:
B29D 30/44 (2017.01) B25J 15/06 (2017.01)

22

Aanvraag ingediend: **15 februari 2017**

41

Aanvraag ingeschreven:
6 september 2018

73

Octrooihouder(s):
VMI Holland B.V. te EPE.

43

Aanvraag gepubliceerd:
-

72

Uitvinder(s):
**Otte Haitzma te EPE.
Jeroen van Tienhoven te EPE.
Peter Rutgers te EPE.**

47

Octrooi verleend:
6 september 2018

45

Octrooischrift uitgegeven:
7 november 2018

74

Gemachtigde:
ir. F.A. Geurts c.s. te Den Haag.

54

Transfer device and method for transferring a tire component

57

The invention relates to a transfer device and method for transferring an at least partially ferromagnetic tire component (9), wherein transfer device comprises a first transfer member (1) and a second transfer member (2) which are movable into a first transfer state on opposite sides of a first transfer plane (P1), wherein the first transfer member (1) comprises first magnetic field sources (11) that form a first magnetic field array (12) for retaining the tire component (9) with a first magnetic attraction force (F1), wherein the second transfer member (2) comprises second magnetic field sources (21) that form a second magnetic field array (22) for retaining the tire component (9) with a second magnetic attraction force (F2) that is larger than the first magnetic attraction force (F1) at the first transfer plane (P1), wherein in the first transfer state the second magnetic field array (22) is offset with respect to the first magnetic field array (12).

NLP200590A

5 Transfer device and method for transferring a tire
component

10 BACKGROUND

The invention relates to a transfer device and a method for transferring a tire component.

US 4,411,724 A discloses an apparatus for
15 splicing cord ply segments. The apparatus is provided with a first retaining member that is constituted by a first electromagnet extending longitudinally of and within the first conveyor, and a second retaining member that is constituted by a second electromagnet extending
20 longitudinally of and within the second conveyor. The electromagnet in the second conveyor is larger in magnetic force than the electromagnet in the first conveyor to the extent that the cord ply segments are able to be transferred from the first conveyor to the second conveyor.
25 The transfer means is constituted by portions of the first and second electromagnets which are overlapped to each other.

While the difference in magnetic force between the electromagnets allows the transfer from the first
30 conveyor to the second conveyor, the electromagnets themselves remain strongly magnetically attracted to each other. Hence, when the conveyors need to be separated from each other, e.g. to move the transferred cord ply segments to another position within the apparatus, said movement may
35 be counteracted by the magnetic force. This is why US 4,411,724 A features complex and expensive electromagnets to transfer the cord ply segments, so that one of said

electromagnets can be switched off to allow separation from the other electromagnet.

It is an object of the present invention to provide a transfer device and a method for transferring a
5 tire component, wherein the complexity and/or cost of the transfer device can be reduced.

SUMMARY OF THE INVENTION

10

According to a first aspect, the invention provides a transfer device for transferring an at least partially ferromagnetic tire component, wherein transfer device comprises a first transfer member and a second
15 transfer member which are movable relative to each other into a first transfer state on opposite sides of a first transfer plane, wherein the first transfer member comprises a plurality of first magnetic field sources that form a first magnetic field array for retaining the tire component
20 to the first transfer member with a first magnetic attraction force, wherein the second transfer member comprises a plurality of second magnetic field sources that form a second magnetic field array for retaining the tire component to the second transfer member with a second
25 magnetic attraction force, wherein in the first transfer state the second magnetic attraction force at the first transfer plane is larger than the first magnetic attraction force at the first transfer plane to transfer the tire component from the first transfer member to the second
30 transfer member, wherein in the first transfer state the second magnetic field array is at least partially offset with respect to the first magnetic field array.

Because of the offset, the magnetic attraction force between the first transfer member and the second
35 transfer member can be reduced significantly, thus allowing for an easy separation of the transfer members after the transfer, without the need for additional separation means

or control of the magnetic attraction forces.

In a preferred embodiment the first transfer member and the second transfer member are movable relative to each other from a pre-transfer state in which the first transfer member and the second transfer member are spaced apart from each other on opposite sides of the first transfer plane at a first mutual distance to the first transfer state in which the first transfer member and the second transfer member are spaced apart from each other on opposite sides of the first transfer plane at a second mutual distance that is smaller than the first mutual distance, and from the first transfer state into a post-transfer state in which the first transfer member and the second transfer member are spaced apart from each other on opposite sides of the first transfer plane at a third mutual distance that is larger than the second mutual distance, wherein the second magnetic field array is at least partially offset with respect to the first magnetic field array in the pre-transfer state, the first transfer state, the post-transfer state and therein between. Hence, the magnetic attraction force between the transfer members can be reduced significantly during both the approach of the transfer members from the pre-transfer state to the first transfer state as well as during the separation of the transfer members from the first transfer state to the post-transfer state.

In a further embodiment, in the first transfer state, the second magnetic field array is offset with respect to the first magnetic field array over a first offset angle about a first offset axis normal to the first transfer plane. Providing an offset about said first offset axis can be a simple yet effective way of misaligning the magnetic fields in the respective arrays.

In an embodiment thereof the first offset angle is chosen within a range of ten to eighty degrees, preferably within a range of twenty to seventy degrees and most preferably within a range of thirty to sixty degrees.

Within said range, the magnetic attraction force between the transfer members can be reduced significantly.

In a further embodiment the first magnetic field sources are arranged in the first magnetic field array in one or more rows parallel to a first pattern direction.

In an embodiment thereof the first magnetic field sources are arranged in the first magnetic field array in one or more columns parallel to a second pattern direction transverse or perpendicular to the first pattern direction.

In a further embodiment thereof the second magnetic field sources are arranged in the second magnetic field array in one or more rows parallel to a third pattern direction.

In an embodiment thereof the second magnetic field sources are arranged in the second magnetic field array in one or more columns parallel to a fourth pattern direction transverse or perpendicular to the third pattern direction.

Hence, the magnetic field sources can be provided in a predetermined pattern to allow for better control of the offset and its effect on the magnetic attraction force between the transfer members.

Preferably, the first pattern direction is different from the third pattern direction. Hence, at least some of the first magnetic field sources in said first pattern direction can be offset with respect to at least some of the second magnetic field sources in the third pattern direction.

Preferably, the second pattern direction is different from the fourth pattern direction. Hence, at least some of the first magnetic field sources in said second pattern direction can be offset with respect to at least some of the second magnetic field sources in the fourth pattern direction.

Preferably, the first magnetic field sources in each row of the first magnetic field array are evenly distributed in the first pattern direction at a first pitch

distance.

Preferably, the first magnetic field sources in each column of the first magnetic field array are evenly distributed in the second pattern direction at a second
5 pitch distance.

Preferably, the second magnetic field sources in each row of the second magnetic field array are evenly distributed in the third pattern direction at a third pitch distance.

10 Preferably, the second magnetic field sources in each column of the second magnetic field array are evenly distributed in the fourth pattern direction at a fourth pitch distance.

By providing the magnetic field sources at a
15 predetermined pitch, the offset and its effect on the magnetic attraction force between the transfer members can be controlled more accurately.

In one embodiment the first pitch distance and the third pitch distance are unequal.

20 In another embodiment the second pitch distance and the fourth pitch distance are unequal.

The unequal pitch can provide an offset between at least some of the first magnetic field sources with respect to the second magnetic field sources.

25 Alternatively, the first magnetic field sources are arranged in the first magnetic field array according to a first random pattern. Preferably, the second magnetic field sources are arranged in the second magnetic field array according to a second random pattern different from
30 the first random pattern. It has been found that different random patterns can also provide a considerable reduction in the magnetic attraction force between the transfer members.

In a further embodiment the plurality of first
35 magnetic field sources comprises a first group of magnets that face towards the first transfer plane with a north magnetic polarity and a second group of magnets that face

towards the first transfer plane with a south magnetic polarity. By providing different polarities, at least some of the first magnetic field sources may repel the second magnetic field sources of the same polarity.

5 In an embodiment thereof the plurality of second magnetic field sources comprises a first group of magnets that face towards the first transfer plane with a north magnetic polarity and a second group of magnets that face towards the first transfer plane with a south magnetic
10 polarity. By providing different polarities, at least some of the second magnetic field sources may repel the first magnetic field sources of the same polarity.

 In a further embodiment thereof the magnets of the first group alternate with the magnets of the second
15 group within a respective one of the magnetic field arrays. The alternation provides for an at least partially repelling magnet array.

 Preferably, the first mutual distance and the third mutual distance are at least five millimeters and
20 most preferably at least ten millimeters. Hence, within said minimum mutual distance range, the offset is provided between the respective arrays.

 In an embodiment the transfer device further comprises at least one drive member for driving the
25 relative movement of the first transfer member and the second transfer member between the pre-transfer state, the first transfer state and the post-transfer state.

 In an embodiment thereof the transfer device further comprises a control unit that is arranged for
30 controlling the at least one drive member for driving the relative movement of the first transfer member and the second transfer member between the pre-transfer state, the first transfer state and the post-transfer state.

 Preferably, the first magnetic field sources, the
35 second magnetic field sources or both are permanent magnets. Permanent magnets are less expensive and less complex than controllable electromagnets.

In an embodiment the transfer device further comprising a third transfer member, wherein the second transfer member and the third transfer member are movable relative to each other into a second transfer state on opposite sides of a second transfer plane, wherein the third transfer member comprises a plurality of third magnetic field sources that form a third magnetic field array for retaining the tire component to the third transfer member with a third magnetic attraction force, wherein in the second transfer state the third magnetic attraction force at the second transfer plane is larger than the second magnetic attraction force at the second transfer plane to transfer the tire component from the second transfer member to the third transfer member, wherein in the second transfer state the third magnetic field array is at least partially offset with respect to the second magnetic field array. The third transfer member can interact with the second transfer member in substantially the same manner as the second transfer member with the first transfer member and can be used to transfer the tire component further. In a preferred embodiment thereof in the second transfer state the third magnetic field array is offset with respect to the second magnetic field array over a second offset angle about a second offset axis normal to the second transfer plane.

In a further preferred embodiment thereof the second offset angle is chosen within a range of ten to eighty degrees, preferably within a range of twenty to seventy degrees and most preferably within a range of thirty to sixty degrees.

In a further embodiment thereof the transfer device further comprises a fourth transfer member or further transfer members that together with the first transfer member, the second transfer member and the third transfer member forms a series of transfer members for consecutively transferring the tire component between successive or consecutive pairs of a delivering transfer

member and a receiving transfer member within the series at
respective transfer planes, wherein each one of the fourth
transfer member or the further transfer members comprises a
plurality of further magnets that forms a further magnet
5 array for retaining the tire component to the one of the
fourth transfer member or the further transfer members with
a further magnetic attraction force, wherein for each
successive or consecutive pair of transfer members the
magnetic attraction force of the receiving transfer member
10 is larger than the magnetic attraction of the delivering
transfer member at the respective transfer plane to
transfer the tire component from the delivering transfer
member to the receiving transfer member, wherein for each
successive or consecutive pair the magnetic field array of
15 the receiving transfer member is at least partially offset
with respect to the magnetic field array of the delivering
transfer member. The fourth transfer member can interact
with the third transfer member in substantially the same
manner as the second transfer member with the first
20 transfer member and can be used to transfer the tire
component further.

In an embodiment thereof, for each pair
successive or consecutive transfer members, the magnetic
field array of each receiving transfer member is offset
25 with respect to the magnetic field array of the delivering
member over an offset angle about a respective offset axis
normal to the respective transfer plane. Hence, for each
pair, an offset angle can be provided that allows for easy
separation of the transfer members within said pair.

30 Preferably, wherein the offset angle for each
pair is at least ten degrees and preferably at least
fifteen degrees. At said minimum offset angle, it has been
found that the magnetic attraction force between the
transfer members can be reduced considerably.

35 More preferably, the offset angle for each pair
is equal to ninety degrees divided by the number of
transfer members within the series. Hence, with a minimum

angle of ten degrees, a maximum of eight pairs of transfer members can be used in series.

In a further embodiment thereof the last transfer member in the series of transfer members is the first
5 transfer member of the same series of transfer members. The first transfer member can thus have multiple functions within the transfer device.

In another embodiment the magnetic attraction force of one of the magnetic field arrays is adjustable.
10 This allows for reducing the magnetic attraction force of said one magnet array. The adjustability may for example be achieved by arranging one or more electromagnets in the respective magnet array. Said electromagnets can be controlled in a range from a maximum magnetic attraction
15 force to zero magnetic attraction force. Using one or more electromagnets can also reduce the tendency of the tire component to jump from one transfer member to another transfer member prior to reaching the respective transfer state.

In an embodiment thereof one of the transfer members comprises a transfer body and a release mechanism that is arranged for moving the respective magnetic field array with respect to said transfer body away from the transfer plane. Said release mechanism can mechanically
25 separate the magnetic field array, thereby reducing the strength of its magnetic field at the transfer plane.

According to a second aspect, the invention provides a method for transferring an at least partially ferromagnetic tire component with the use of a transfer
30 device according to any one of the aforementioned embodiments, wherein the method comprises the steps of:

retaining the tire component to the first transfer member with the first magnetic attraction force;
moving the first transfer member and the second
35 transfer member relative to each other into the first transfer state on opposite sides of the first transfer plane;

retaining the tire component to the second transfer member with the second magnetic attraction force, wherein in the first transfer state the second magnetic attraction force at the first transfer plane is larger than
5 the first magnetic attraction force at the first transfer plane; and

transferring the tire component from the first transfer member to the second transfer member,

10 wherein in the first transfer state the second magnetic field array is at least partially offset with respect to the first magnetic field array.

This method relates to the implementation of the transfer device and thus has the same technical advantages as the aforementioned transfer device and its embodiments.

15 In a preferred embodiment the method further comprises the steps of:

moving the first transfer member and the second transfer member relative to each other from a pre-transfer state in which the first transfer member and the second
20 transfer member are spaced apart from each other on opposite sides of the first transfer plane at a first mutual distance;

moving the first transfer member and the second transfer member relative to each other from the pre-
25 transfer state into the first transfer state in which the first transfer member and the second transfer member are spaced apart from each other on opposite sides of the first transfer plane at a second mutual distance that is smaller than the first mutual distance; and

30 moving the first transfer member and the second transfer member relative to each other from the first transfer state into a post-transfer state in which the first transfer member and the second transfer member are spaced apart from each other on opposite sides of the first
35 transfer plane at a third mutual distance that is larger than the second mutual distance,

wherein the second magnetic field array is at

least partially offset with respect to the first magnetic field array in the pre-transfer state, the first transfer state, the post-transfer state and therein between.

5 The various aspects and features described and shown in the specification can be applied, individually, wherever possible. These individual aspects, in particular the aspects and features described in the attached dependent claims, can be made subject of divisional patent applications.

10

BRIEF DESCRIPTION OF THE DRAWINGS

15 The invention will be elucidated on the basis of an exemplary embodiment shown in the attached schematic drawings, in which:

figure 1 shows an isometric view of a transfer device for transferring a tire component, comprising a first transfer member, a second transfer member and a third transfer member according to a first exemplary embodiment of the invention;

25 figures 2, 3 and 4 show front views of the first transfer member and the second transfer member during exemplary steps of a method for transferring the tire component;

figure 5 shows a bottom view of the first transfer member along the line V-V in figure 2;

figure 6 shows a top view of the second transfer member along the line VI-VI in figure 2;

30 figure 7 shows a top view of an alternative second transfer member according to a second exemplary embodiment of the invention;

figure 8 shows an overlay of the bottom view of first transfer member with the bottom view of the second transfer member according to the line VIII-VIII in figure 3;

figure 9 shows an alternative overlay of the

bottom view of the first transfer member according to figure 5 with the top view of the alternative second transfer member according to figure 7;

5 figures 10A-10I show schematic front views of the first transfer member, the second transfer member and the third transfer member according to figure 1 during exemplary steps of the method for transferring the tire component; and

10 figures 11, 12 and 13 show a possible configuration of the first transfer member, the second transfer member and the third transfer member, respectively, during the steps of the method in figures 10A-10I; and

15 figures 14A and 14B show the first transfer member and the second transfer member during the steps of an alternative method for releasing the tire component.

20 DETAILED DESCRIPTION OF THE INVENTION

Figure 1 shows a transfer device for transferring an at least partially ferromagnetic tire component 9 according to an exemplary embodiment of the invention. The 25 tire component 9 typically comprises an elastomeric body with embedded ferromagnetic, metal or steel reinforcement cords.

The transfer device comprises a first transfer member 1, a second transfer member 2 and a third transfer 30 member 3. The first transfer member 1 is mounted to the end of a first drive member 71, in this example a robotic manipulator or a robot arm. As such, the first transfer member 1 may be regarded as a gripper at the end of a robotic manipulator 71. In this exemplary embodiment, the 35 shape or contour of the first transfer member 1 is adapted to match or substantially match the parallelogram shape of the tire component 9. The second transfer member 2 is

coupled a second drive member 72 so as to be rotatable about a turn-table axis T. As such, the second transfer member 2 may be regarded as a turn-table for turning-over or flipping the tire component 9. The third transfer member 3 is placed directly underneath an endless belt of a belt conveyor 33. As such, the third transfer member 3 may be regarded as a functional component of said belt conveyor 33.

It will however be apparent to one skilled in the art that the transfer members 1, 2, 3 may be used in various alternative applications where an at least partially ferromagnetic tire component 9 requires transfer from one transfer member to the other transfer member. The description hereafter refers to the transfer of an at least partially ferromagnetic tire component 9 between generic transfer members 1, 2, 3, not limited to the application as shown in the exemplary drawings.

As shown in figure 1, the first transfer device 1 comprises a first transfer body 10 and a plurality of first magnetic field sources 11 mounted in or to said first transfer body 10 to form a first magnetic field matrix or array 12 for retaining the tire component 9 to the first transfer body 10 of the first transfer member 1 with a first magnetic attraction force F_1 . The second transfer device 2 comprises a second transfer body 20 and a plurality of second magnetic field sources 21 mounted in or to said second transfer body 20 to form a second magnetic field matrix or array 22 for retaining the tire component 9 to the second transfer body 20 of the second transfer member 2 with a second magnetic attraction force F_2 . The third transfer device 3 comprises a third transfer body 30 and a plurality of third magnetic field sources 31 mounted in or to said third transfer body 30 to form a third magnet matrix or array 32 for retaining the tire component 9 to the third transfer body 30 of the third transfer member 3 with a third magnetic attraction force F_3 . The first magnetic field sources 11, the second magnetic field

sources 21 and/or the third magnetic field sources 31 may be individual magnets or integrated magnet bodies that generate individual magnetic fields.

5 Figures 2-4 shows the steps of a method for transferring the tire component 9 from the first transfer member 1 to the second transfer member 2.

Figure 2 shows that the first transfer member 1 and the second transfer member 2 are moved relative to each other into a pre-transfer state in which the first transfer member 1 and the second transfer member 2 are spaced apart from each other on opposite sides of the first transfer plane P1. In said pre-transfer state, the first transfer member 1 and the second transfer member 2 are spaced apart at a first mutual distance Z1.

15 Figure 3 shows that the first transfer member 1 and the second transfer member 2 are subsequently moved relative to each other from the pre-transfer state, as shown in figure 2, into a first transfer state in which the first transfer member 1 and the second transfer member 2 are spaced apart from each other on opposite sides of the first transfer plane P1 at a second mutual distance Z2 that is smaller than the first mutual distance Z1. In particular, the second mutual distance Z2 is chosen to be substantially equal to the thickness of the tire component 9 so that both the first transfer member 1 and the second transfer member 2 may be arranged in abutting contact with the tire component 9 at opposite sides of the first transfer plane P1. Hence, the tire component 9 can be transferred from the first transfer member 1 to the second transfer member 2 without letting go of said tire component 9. In this exemplary embodiment, the first transfer member 1 and the second transfer member 2 are moved relative to each other by moving the first transfer member 1 with the use of the first drive member 71 towards the second transfer member 2. Preferably, the first transfer member 1 and the second transfer member 2 are movable relative to each other in a direction normal and/or perpendicular to

the first transfer plane P1.

Figure 4 shows that the first transfer member 1 and the second transfer member 2 are subsequently moved relative to each other from the first transfer state, as shown in figure 3, into a post-transfer state in which the first transfer member 1 and the second transfer member 2 are spaced apart from each other on opposite sides of the first transfer plane P1 at a third mutual distance Z3 that is larger than the second mutual distance Z2.

The second magnetic attraction force F2 is larger than the first magnetic attraction force F1 to ensure that the tire component 9 is actually transferred from the first transfer member 1 to the second transfer member 2 when the first transfer member 1 and the second transfer member 2 move from the first transfer state into the post-transfer state.

When the first transfer member 1 and the second transfer member 2 are positioned in the first transfer state at opposite sides of the first transfer plane P1, as in figure 3, the first magnetic field array 12 of the first transfer member 1 may be magnetically attracted to the second magnetic field array 22 of the second transfer member 2. This magnetic attraction between the respective transfer members 1, 2 could potentially counteract the relative movement of said transfer members 1, 2 apart from each other. Hence, to reduce and/or prevent magnetic attraction between the first transfer member 1 and the second transfer member 2 in the first transfer state, the second magnetic field array 22 is at least partially offset with respect to the first magnetic field array 12. 'Partially offset', in the context of the present invention, means that at least some of the first magnetic field sources 11 of the first magnetic field array 12 are misaligned and/or shifted, e.g. by rotation, translation or change in pitch distance, with respect to some of the second magnetic field sources 21 of the second magnetic field array 22. Hence, while the first transfer member 1

and the second transfer member 2 can individually magnetically attract the tire component 9 with the first magnetic attraction force F_1 and the second magnetic attraction force F_2 , respectively, the magnetic attraction
5 between the first transfer member 1 and the second transfer member 2 can be kept to a minimum. Thus, less effort is required to separate the first transfer member 1 and the second transfer member 2.

Preferably, the second magnetic field array 22 is
10 at least partially offset with respect to the first magnetic field array 12 in the pre-transfer state, the first transfer state, the post-transfer state and therein between. Hence, both during the mutual approach as well as during the separation of the first transfer member 1 and
15 the second transfer member 2, the magnetic attraction between the first transfer member 1 and the second transfer member 2 can be kept to a minimum. This prevents that the magnetic attraction negatively influences the accuracy of the positioning of the first transfer member 1 with respect
20 to the second transfer member 2.

In the pre-transfer state of figure 2 and the post-transfer state of figure 4, the first mutual distance Z_1 and the third mutual distance Z_3 between the first transfer member 1 and the second transfer member 2 is at
25 least five millimeters and more preferably at least ten millimeters. When moving the first transfer member 1 and the second transfer member 2 apart towards the upper end of said range, the magnetic attraction force between the first transfer member 1 and the second transfer member 2 is
30 negligible. It is preferred to keep the first magnetic field array 12 and the second magnetic field array 22 at least partially misaligned when the first transfer member 1 and the second transfer member 2 are within said range.

Figure 5 shows an example of a possible
35 configuration of the first magnetic field array 12. The first magnetic field sources 11 of said first magnetic field array 12 are arranged in mutually parallel rows and

columns extending in a first pattern direction D1 and a second pattern direction D2, respectively. Preferably, the first magnetic field sources 11 in each row are evenly distributed in the first pattern direction D1 at a first pitch distance X1. Preferably, the first magnetic field sources 11 in each column are also evenly distributed in the second pattern direction D2 at a second pitch distance X2. 'Pitch distance', in the context of the present invention, means the center-to-center or heart distance between two directly adjacent first magnetic field sources 11 in a respective row or column of the first magnetic field array 12. In this exemplary embodiment, the plurality of first magnetic field sources 11 comprises a first group of magnets that face towards the first transfer plane P1 with a north magnetic polarity N and a second group of magnets that face towards the first transfer plane P1 with a south magnetic polarity S. Preferably, the magnets of the first group alternate with the magnets of the second group.

Figure 6 shows an example of a possible configuration of the second magnetic field array 22. The second magnetic field sources 21 of said second magnetic field array 22 are arranged in mutually parallel rows and columns extending in a third pattern direction D3 and a fourth pattern direction D4, respectively. Preferably, the second magnetic field sources 21 in each row are evenly distributed in the third pattern direction D3 at a third pitch distance X3. Preferably, the second magnetic field sources 21 in each column are also evenly distributed in the fourth pattern direction D4 at a fourth pitch distance X4. 'Pitch distance', in the context of the present invention, means the center-to-center or heart distance between two directly adjacent second magnetic field sources 21 in a respective row or column of the second magnetic field array 22. In this exemplary embodiment, the plurality of second magnetic field sources 21 comprises a first group of magnets that face towards the first transfer plane P1 with a north magnetic polarity N and a second group of

magnets that face towards the first transfer plane P1 with a south magnetic polarity S. Preferably, the magnets of the first group alternate with the magnets of the second group.

Figure 7 shows an example of a possible alternative configuration of a second magnetic field array 122 of an alternative second transfer member 102. In said second magnetic field array 122, the second magnetic field sources 121 are again arranged in mutually parallel rows and columns extending in a third pattern direction D3 and a fourth pattern direction D4, respectively. The second magnetic field sources 121 in each row are evenly distributed in the third pattern direction D3 at an alternative third pitch distance X3 that is smaller than the first pitch distance X1. The second magnetic field sources 121 in each column are also evenly distributed in the fourth pattern direction D4 at an alternative fourth pitch distance X4 that is smaller than the second pitch distance X2. Preferably, the third pitch distance X3 and the fourth pitch distance X4 are at least two times smaller than the first pitch distance X1 and the second pitch distance X2, respectively.

Figure 8 shows an overlay of the first transfer member 1 according to figure 5 with the second transfer member 2 according to figure 6 in the first transfer position of figure 3. Figure 8 clearly shows that the second magnetic field array 22 is offset with respect to the first magnetic field array 12 by rotation of said second magnetic field array 22 with respect to the first magnetic field array 12 over a first offset angle A1 about a first offset axis R1 normal and/or perpendicular to the first transfer plane P1. Consequently, the third pattern direction D3 is offset with respect to the first pattern direction D1 over the first offset angle A1 and the fourth pattern direction D4 is offset with respect to the second pattern direction D2 over the first offset angle A1. In this example, the first offset angle A1 is approximately forty-five (45) degrees. As clearly shown in figure 8, the

first offset angle A_1 causes a relative shift between the first magnetic field array 12 and the second magnetic field array 22 such that many of the first magnetic field sources 11 are misaligned with and/or only partially overlapped by the second magnetic field sources 21. This reduces the magnetic attraction between the first transfer member 1 and the second transfer member 2 to a minimum.

It has been found that a first offset angle A_1 in the range of ten (10) to eighty (80) degrees is also possible to achieve a considerable reduction in the magnetic attraction between the first transfer member 1 and the second transfer member 2.

Figure 9 shows an overlay of the first transfer member 1 according to figure 5 with the alternative second transfer member 102 according to figure 7 in the first transfer position of figure 3. Figure 9 clearly shows that the second magnetic field array 122 is offset with respect to the first magnetic field array 12 by a mismatch of the first pitch distance X_1 and the second pitch distance X_2 with the third pitch distance X_3 and the fourth pitch distance X_4 , respectively. In particular, for a substantial part of the overlay, one of the first magnetic field sources 11 overlaps with four of the second magnetic field sources 121. Of said four second magnetic field sources 121, at least two are of equal polarity than the polarity of the oppositely located first magnetic field source 11, thereby at least partially repelling said respective first magnetic field source 11. Hence, the magnetic attraction between the first transfer member 1 and the second transfer member 2 can be reduced significantly and could potentially be reduced towards zero.

Figures 10A-10I shows the steps of a more complex method for transferring the tire component 9 from the first transfer member 1 to the second transfer member 2, from the second transfer member 2 to the third transfer member 3 and from the third transfer member 3 to a fourth transfer member 4 or back to the first transfer member 1.

The steps as shown in figures 10A-10C correspond to the steps of transferring the tire component 9 between the first transfer member 1 and the second transfer member 2, as shown in figures 2-4. Figure 10D shows the situation in which the second drive member 32 has been actuated to turn-over and/or flip the first transfer member 1 and the tire component 9 received thereon about the turn-table axis T from the first transfer plane P1 towards a second transfer plane P2 at the third transfer member 3. During the turning-over, the second magnetic field array 22 at the second transfer member 2 retains the tire component 9 to the second transfer member 2, even when the transfer member 2 is turned up-side-down with respect to the orientation as shown in figure 10C.

Figure 10E shows the situation in which the second transfer member 2 has been turned-over fully into a position opposite to the third transfer member 3 with respect to the second transfer plane P2. This is referred to as the second transfer state, in which the third transfer member 3 are moved relative to each other into respective positions on opposite sides of the second transfer plane P2. Although the approach of the second transfer member 2 towards the third transfer member 3 is the result of a rotation about the turn-table axis T, it is noted that the very last part of said rotation, meaning the last few degrees of rotation and/or the last five to ten millimeters until its end position, can be considered as a substantially linear approach. Hence, the second transfer member 2 and the third transfer member 3 move through a pre-transfer state, the second transfer state and a post-transfer state in essentially the same manner as the first transfer member 1 and the second transfer member 2 with respect to the first transfer state.

In figure 10E, the third magnetic attraction force F3 is larger than the second magnetic attraction force F2 to ensure that the tire component 9 is actually transferred from the second transfer member 2 to the third

transfer member 3 when the second transfer member 2 and the third transfer member 3 move from the second transfer state into the post-transfer state.

5 Figure 10F shows the situation in which the second transfer member 2 is moved from the second transfer state through the post-transfer state away from the third transfer member 3, leaving the tire component 9 at the endless belt of the belt conveyor 33 at said third transfer member 3.

10 Figures 10F and 10G show how a fourth transfer member 4, which in this example is in fact the first transfer member 1, is arranged for picking up the turned-over tire component 9 from the endless belt of the belt conveyor 33 at the third transfer member 3. Figures 10G, 15 10H and 10I essentially correspond to figures 10A, 10B and 10C, respectively, yet at the second transfer plane P2 and with the transfer of the tire component 9 occurring between the third transfer member 3 and the fourth transfer member 4.

20 In the second transfer state the third magnetic field array 32 is at least partially offset with respect to the second magnetic field array 22. In this exemplary embodiment, the offset between the third magnetic field array 32 and the second magnetic field array 22 is a 25 rotational offset of the third magnetic field array 32 with respect to the second magnetic field array 22 over a second offset angle A2 about a second offset axis R2 that extends normal and/or perpendicular to the second transfer plane P2. Again, the offset may be a misalignment or shift of the 30 third magnetic field sources 31 with respect to the second magnetic field sources 21, e.g. by rotation, translation or change in pitch distance.

35 Figures 11, 12 and 13 show three possible configurations for the first magnetic field array 212, the second magnetic field array 222 and the third magnetic field array 232. As shown in figure 11, the first magnetic field sources 211 are arranged in mutually parallel rows

and columns extending in a first pattern direction D1 and a second pattern direction D2, respectively. As shown in figure 12, the second magnetic field sources 221 are arranged in mutually parallel rows and columns extending in a third pattern direction D3 and a fourth pattern direction D4, respectively, which are offset with respect to the first pattern direction D1 and the second pattern direction D2, respectively, over a first offset angle A1 about the first offset axis R1. As shown in figure 13, the third magnetic field sources 231 are arranged in mutually parallel rows and columns extending in a fifth pattern direction D5 and a sixth pattern direction D6, respectively, which are offset with respect to the first pattern direction D1 and the second pattern direction D2, respectively, over a second offset angle A2 about a second offset axis R2.

The first offset angle A1 and the second offset angle A2 are preferably equal. In this exemplary embodiment, the first offset angle A1 and the second offset angle A2 are both approximately thirty (30) degrees. The offset angles A1, A2 are preferably chosen so that each magnet array 212, 222, 232 is misaligned with respect to other magnet arrays 212, 222, 232 that are used in the same transfer device. Hence, every transfer member 1, 2, 3 has a different magnet array 212, 222, 232. This provides more flexibility, as the first transfer member 1 may also cooperate with the third transfer member 3 instead of the second transfer member 2. Preferably, the offset angles A1, A2 are chosen to be equal or substantially equal to ninety (90) degrees divided by the number of transfer members 1, 2, 3 in the transfer device. The offset angles A1, A2 should not be less than ten (10) degrees to maintain a sufficient decrease in the magnetic attraction between the transfer members 1, 2, 3. Consequently, it would be possible to provide a series of up to eight transfer members (not shown), each with a magnet array that is offset over an angle of at least ten degrees (10) with

respect to each of the other magnet arrays.

Within said series, consecutive or successive pairs of transfer members are arranged for transferring the tire component 9 at respective transfer planes. Each consecutive or successive pair of transfer members comprises a receiving transfer member that receives the tire component 9 and a delivering transfer member that delivers the tire component 9 to the receiving transfer member. The magnetic attraction force of the receiving transfer member is larger than the magnetic attraction of the delivering transfer member at the respective transfer plane to transfer the tire component 9 from the delivering transfer member to the receiving transfer member.

The previously discussed magnets 11, 21, 31, 121, 211, 221, 231 are preferably permanent magnets. The construction of the transfer members 1, 2, 3, 102 can thus be kept relatively simple yet very effective. There are exceptions however, where a slightly more complex magnet configuration for at least one of the transfer members is desirable.

For example, the last transfer member in the series - in figures 10G, 10H and 10I the fourth transfer member 4 - may also be formed by the first transfer member 1 of the same series. However, as the magnetic attraction forces F1, F2, F3 have become incrementally stronger with each transfer, the second to last magnetic attraction force F3 is considerably larger than the last magnetic attraction force F1 generated by the first transfer member 1 of the series. Hence, it will be difficult to transfer the tire component 9 between the second to last transfer member 3 and the last transfer member 4 in the form of the first transfer member 1. It has been found however that when one of the magnetic attraction forces is adjustable, e.g. by providing an adjustable electromagnet or by mechanically adjusting the spacing between the magnets and the tire component 9, the magnetic attraction force can be controlled to a level that allows for the transfer of the

tire component 9. In the example as shown in figure 1, the third transfer member 3 may be lowered with a release mechanism 5, as shown in figure 14A, to increase the spacing between tire component 9 supported at the endless belt of the belt conveyor 33 and the magnets 31 of the third transfer member 3, thereby release the third transfer member 3 to the first transfer member 1. Alternatively, the first transfer member 1 may be provided with one or more electromagnets with a capacity sufficient to provide a fourth magnetic attraction force F_4 , as shown in figure 14B, that exceeds the third magnetic attraction force F_3 .

In an alternative embodiment, the transfer members may be provided with magnet arrays in which the magnets are arranged in random patterns (not shown), wherein the random pattern is different for each transfer member. Although probably not as effective as the predetermined patterns as previously discussed, the random pattern could provide sufficient misalignment to at least partially reduce the magnetic attraction between the respective transfer members.

It is to be understood that the above description is included to illustrate the operation of the preferred embodiments and is not meant to limit the scope of the invention. From the above discussion, many variations will be apparent to one skilled in the art that would yet be encompassed by the scope of the present invention.

In summary, the invention relates to a transfer device and method for transferring an at least partially ferromagnetic tire component (9), wherein transfer device comprises a first transfer member (1) and a second transfer member (2) which are movable into a first transfer state on opposite sides of a first transfer plane (P1), wherein the first transfer member (1) comprises first magnetic field sources (11) that form a first magnetic field array (12) for retaining the tire component (9) with a first magnetic attraction force (F_1), wherein the second transfer member (2) comprises second magnetic field sources (21) that form

a second magnetic field array (22) for retaining the tire component (9) with a second magnetic attraction force (F2) that is larger than the first magnetic attraction force (F1) at the first transfer plane (P1), wherein in the first 5 transfer state the second magnetic field array (22) is offset with respect to the first magnetic field array (12).

C O N C L U S I E S

1. Overdraaginrichting voor het overdragen van een ten minste gedeeltelijk ferromagnetische bandcomponent (9), waarbij de overdraaginrichting een eerste overdraagdeel (1) en een tweede overdraagdeel (2, 102) 5 omvat welke beweegbaar zijn ten opzichte van elkaar in een eerste overdraagtoestand aan weerszijden van een eerste overdraagvlak (P1), waarbij het eerste overdraagdeel (1) een meervoud van eerste magneetveldbronnen (11, 211) omvat die een eerste magneetveldreeks (12, 212) vormen voor het 10 vasthouden van de bandcomponent (9) aan het eerste overdraagdeel (1) met een eerste magnetische aantrekkingskracht (F1), waarbij het tweede overdraagdeel (2, 102) een meervoud van tweede magneetveldbronnen (21, 121, 221) omvat die een tweede magneetveldreeks (22, 122, 15 222) vormen voor het vasthouden van de bandcomponent (9) aan het tweede overdraagdeel (2) met een tweede magnetische aantrekkingskracht (F2), waarbij in de eerste overdraagtoestand de tweede magnetische aantrekkingskracht (F2) bij het eerste overdraagvlak (P1) groter is dan de 20 eerste magnetische aantrekkingskracht (F1) bij het eerste overdraagvlak (P1) teneinde de bandcomponent (9) over te dragen van het eerste overdraagdeel (1) naar het tweede overdraagdeel (2, 102), waarbij in de eerste overdraagtoestand de tweede magneetveldreeks (22, 122, 222) 25 ten minste gedeeltelijk verschoven is ten opzichte van de eerste magneetveldreeks (12, 212).

2. Overdraaginrichting volgens conclusie 1, waarbij het eerste overdraagdeel (1) en het tweede overdraagdeel (2, 102) beweegbaar zijn ten opzichte van 30 elkaar van een pre-overdraagtoestand waarin het eerste overdraagdeel (1) en het tweede overdraagdeel (2, 102) op aftand liggen aan weerszijden van het eerste overdraagvlak (P1) op een eerste onderlinge afstand (Z1) naar de eerste

overdraagtoestand waarin het eerste overdraagdeel (1) en het tweede overdraagdeel (2, 102) op afstand van elkaar liggen aan weerszijden van het eerste overdraagvlak (P1) op een tweede onderlinge afstand (Z2) die kleiner is dan de eerste onderlinge afstand (Z1), en van de eerste overdraagtoestand naar een post-overdraagtoestand waarin het eerste overdraagdeel (1) en het tweede overdraagdeel (2, 102) op afstand liggen van elkaar aan weerszijden van het eerste overdraagvlak (P1) op een derde onderlinge afstand (Z3) die groter is dan de tweede onderlinge afstand (Z2), waarbij de tweede magneetveldreeks (22) ten minste gedeeltelijk is verschoven ten opzichte van de eerste magneetveldreeks (12, 212) in de pre-overdraagtoestand, de eerste overdraagtoestand, de post-overdraagtoestand en daartussenin.

3. Overdraaginrichting volgens conclusie 1 of 2, waarbij in de eerste overdraagtoestand de tweede magneetveldreeks (22, 122, 222) verschoven is ten opzichte van de eerste magneetveldreeks (12, 212) over een eerste verschuivingshoek (A1) om een eerste verschuivingshartlijn (R1) loodrecht op het eerste overdraagvlak (P1).

4. Overdraaginrichting volgens conclusie 3, waarbij de eerste verschuivingshoek (A1) wordt gekozen binnen een bereik van tien tot tachtig graden, bij voorkeur binnen een bereik van twintig tot zeventig graden en bij meeste voorkeur binnen een bereik van dertig tot zestig graden.

5. Overdraaginrichting volgens een der voorgaande conclusies, waarbij de eerste magneetveldbronnen (11, 211) zijn aangebracht in de eerste magneetveldreeks (12, 212) in één of meerdere rijen parallel aan een eerste patroonrichting (D1).

6. Overdraaginrichting volgens conclusie 5, waarbij de eerste magneetveldbronnen (11, 211) zijn aangebracht in de eerste magneetveldreeks (12, 212) in één of meerdere kolommen parallel aan een tweede patroonrichting (D2) dwars of loodrecht op de eerste

patroonrichting (D1).

7. Overdraaginrichting volgens conclusie 5 of 6, waarbij de tweede magneetveldbronnen (21, 121, 221) zijn
aangebracht in de tweede magneetveldreeks (22, 122, 222) in
5 één of meerdere rijen parallel aan een derde
patroonrichting (D3).

8. Overdraaginrichting volgens conclusie 7, waarbij de tweede magneetveldbronnen (21, 121, 221) zijn
aangebracht in de tweede magneetveldreeks (22, 122, 222) in
10 één of meerdere kolommen parallel aan een de vierde
patroonrichting (D4) dwars of loodrecht op de derde
patroonrichting (D3).

9. Overdraaginrichting volgens conclusie 7, waarbij de eerste patroonrichting (D1) anders is dan de
15 derde patroonrichting (D3).

10. Overdraaginrichting volgens conclusie 8, waarbij de tweede patroonrichting (D2) anders is dan de
vierde patroonrichting (D4).

11. Overdraaginrichting volgens een der
20 conclusies 5-10, waarbij de eerste magneetveldbronnen (11, 211) in elke rij van de eerste magneetveldreeks (12, 212) gelijkmatig verdeeld zijn in de eerste patroonrichting (D1) op een eerste pitch-afstand (X1).

12. Overdraaginrichting volgens een der
25 conclusies 6-10, waarbij de eerste magneetveldbronnen (11, 211) in elke kolom van de eerste magneetveldreeks (12, 212) gelijkmatig verdeeld zijn in de tweede patroonrichting (D2) op een de tweede pitch-afstand (X2).

13. Overdraaginrichting volgens een der
30 conclusies 7-10, waarbij de tweede magneetveldbronnen (21, 121, 221) in elke rij van de tweede magneetveldreeks (22, 122, 222) gelijkmatig verdeeld zijn in de derde patroonrichting (D3) op een de derde pitch-afstand (X3).

14. Overdraaginrichting volgens een der
35 conclusies 8-10, waarbij de tweede magneetveldbronnen (21, 121, 221) in elke kolom van de tweede magneetveldreeks (22, 122, 222) gelijkmatig verdeeld zijn in de vierde

patroonrichting (D4) op een de vierde pitch-afstand (X4).

15. Overdraaginrichting volgens conclusies 11 en 13, waarbij de eerste pitch-afstand (X1) en de derde pitch-afstand (X3) ongelijk zijn.

5 16. Overdraaginrichting volgens conclusies 12 en 14, waarbij de tweede pitch-afstand (X2) en de vierde pitch-afstand (X4) ongelijk zijn.

10 17. Overdraaginrichting volgens conclusie 1, waarbij de eerste magneetveldbronnen zijn aangebracht in de eerste magneetveldreeks volgens een eerste willekeurig patroon.

15 18. Overdraaginrichting volgens conclusie 17, waarbij de tweede magneetveldbronnen zijn aangebracht in de tweede magneetveldreeks volgens een tweede willekeurig patroon anders dan het eerste willekeurige patroon.

20 19. Overdraaginrichting volgens een der voorgaande conclusies, waarbij het meervoud van eerste magneetveldbronnen (11, 211) een eerste groep van magneten omvat die gericht is naar het eerste overdraagvlak (P1) met een magnetische noordpool (N) en een tweede groep van magneten die gericht is naar het eerste overdraagvlak (P1) met een magnetische zuidpool (S).

25 20. Overdraaginrichting volgens conclusie 19, waarbij het meervoud van tweede magneetveldbronnen (21, 121, 221) een eerste groep van magneten omvat die gericht is naar het eerste overdraagvlak (P1) met een magnetische noordpool (N) en een tweede groep van magneten die gericht is naar het eerste overdraagvlak (P1) met een magnetische zuidpool (S).

30 21. Overdraaginrichting volgens conclusie 19 of 20, waarbij de magneten van de eerste groep alterneren met de magneten van de tweede groep binnen de desbetreffende magneetveldreeks (12, 22, 122, 212, 222).

35 22. Overdraaginrichting volgens conclusie 2, waarbij de eerste onderlinge afstand (Z1) en de derde onderlinge afstand (Z3) ten minste vijf millimeter zijn en meest bij voorkeur ten minste tien millimeter.

23. Overdraaginrichting volgens conclusie 2, waarbij de overdraaginrichting verder ten minste één aandrijfdeel (71) omvat voor het aandrijven van de relatieve beweging van het eerste overdraagdeel (1) en het
5 tweede overdraagdeel (2, 102) tussen de pre-overdraagtoestand, de eerste overdraagtoestand en de post-overdraagtoestand.

24. Overdraaginrichting volgens conclusie 23, waarbij de overdraaginrichting verder een stuureenheid (8)
10 omvat die is ingericht voor het aansturen van het ten minste ene aandrijfdeel (71) voor het aandrijven van de relatieve beweging van het eerste overdraagdeel (1) en het tweede overdraagdeel (2, 102) tussen de pre-overdraagtoestand, de eerste overdraagtoestand en de post-overdraagtoestand.
15

25. Overdraaginrichting volgens een der voorgaande conclusies, waarbij de eerste magneetveldbronnen (11, 211), de tweede magneetveldbronnen (21, 121, 221) of beide permanente magneten zijn.

20 26. Overdraaginrichting volgens een der voorgaande conclusies, verder omvattend een derde overdraagdeel (3), waarbij het tweede overdraagdeel (2, 102) en het derde overdraagdeel (3) beweegbaar zijn ten opzichte van elkaar in een tweede overdraagtoestand aan
25 weerszijden van een het tweede overdraagvlak (P2), waarbij het derde overdraagdeel (3) een meervoud van derde magneetveldbronnen (31, 231) omvat die een derde magneetveldreeks (32, 232) vormen voor het vasthouden van de bandcomponent aan het derde overdraagdeel (3) met een de
30 derde magnetische aantrekkingskracht (F3), waarbij in de tweede overdraagtoestand de derde magnetische aantrekkingskracht (F3) bij het tweede overdraagvlak (P2) groter is dan de tweede magnetische aantrekkingskracht (F2) bij het tweede overdraagvlak (P2) teneinde de bandcomponent
35 (9) over te dragen van het tweede overdraagdeel (2, 102) naar het derde overdraagdeel (3), waarbij in de tweede overdraagtoestand de derde magneetveldreeks (32, 232) ten

minste gedeeltelijk verschoven is ten opzichte van de tweede magneetveldreeks (22, 122, 222).

27. Overdraaginrichting volgens conclusie 26, waarbij in de tweede overdraagtoestand de derde
5 magneetveldreeks verschoven is ten opzichte van de tweede magneetveldreeks (22, 122, 222) over een tweede verschuivingshoek (A2) om een de tweede verschuivingshartlijn (R2) loodrecht op het tweede overdraagvlak (P2).

10 28. Overdraaginrichting volgens conclusie 27, waarbij de tweede verschuivingshoek (A2) wordt gekozen binnen een bereik van tien tot tachtig graden, bij voorkeur binnen een bereik van twintig tot zeventig graden en bij meeste voorkeur binnen een bereik van dertig tot zestig
15 graden.

29. Overdraaginrichting volgens een der conclusies 26-28, waarbij de overdraaginrichting verder een vierde overdraagdeel (4) of verdere overdraagdelen omvat dat samen met het eerste overdraagdeel (1), het tweede
20 overdraagdeel (2, 102) en het derde overdraagdeel (3) een serie van overdraagdelen vormt voor het achtereenvolgend overdragen van de bandcomponent (9) tussen opeenvolgende of achtereenvolgende paren van een afleverend overdraagdeel en een ontvangend overdraagdeel (1, 2, 102; 2, 102, 3; 3, 4)
25 binnen de serie bij desbetreffende overdraagvlakken (P1; P2), waarbij elke van het vierde overdraagdeel (4) of de verdere overdraagdelen een meervoud van verdere magneten omvat die een verdere magneetreeks vormen voor het vasthouden van de bandcomponent (9) aan een desbetreffende
30 van het vierde overdraagdeel (4) of de verdere overdraagdelen met een verdere magnetische aantrekkingskracht, waarbij voor elk opeenvolgend of achtereenvolgend paar van overdraagdelen (1, 2, 102; 2, 102, 3; 3, 4) de magnetische aantrekking van het
35 ontvangende overdraagdeel groter is dan de magnetische aantrekking van het afleverende overdraagdeel bij het desbetreffende overdraagvlak (P1, P2) teneinde de

bandcomponent (9) over te dragen van het afleverende overdraagdeel naar het ontvangende overdraagdeel, waarbij voor elk opeenvolgend of achtereenvolgend paar van overdraagdelen (1, 2, 102; 2, 102, 3; 3, 4) de
5 magneetveldreeks van het ontvangende overdraagdeel ten minste gedeeltelijk is verschoven ten opzichte van de magneetveldreeks van het afleverende overdraagdeel.

30. Overdraaginrichting volgens conclusie 29, waarbij voor elk paar de magneetveldreeks van elk
10 ontvangend overdraagdeel verschoven is ten opzichte van de magneetveldreeks van het afleverende overdraagdeel over een verschuivingshoek (A1, A2) om een desbetreffende verschuivingshartlijn (R1, R2) loodrecht op het desbetreffende overdraagvlak (P1, P2).

15 31. Overdraaginrichting volgens conclusie 30, waarbij de verschuivingshoek (A1, A2) voor elk paar ten minste tien graden is en bij voorkeur ten minste vijftien graden.

20 32. Overdraaginrichting volgens conclusie 30 of 31, waarbij de verschuivingshoek (A1, A2) voor elk paar gelijk is aan negentig graden gedeeld door het aantal overdraagdelen binnen de serie.

25 33. Overdraaginrichting volgens een der conclusies 29-32, waarbij het laatste overdraagdeel (4) in de serie van overdraagdelen (1-4) het eerste overdraagdeel (1) is van dezelfde serie van overdraagdelen (1-4).

30 34. Overdraaginrichting volgens een der voorgaande conclusies, waarbij de magnetische aantrekkingskracht (F1-F3) van een van de magneetveldreeksen (12, 22, 32, 122, 212, 222, 232) instelbaar is.

35 35. Overdraaginrichting volgens een der voorgaande conclusies, waarbij een van de overdraagdelen (1-4) een overdraaglichaam (10) en een loslaatmechanisme (5) dat is ingericht voor het weg van het overdraagvlak (P1, P2) bewegen van de desbetreffende magneetveldreeks (12, 22, 32, 122, 212, 222, 232) ten opzichte van het

overdraaglichaam (10).

36. Werkwijze voor het overdragen van een ten minste gedeeltelijk ferromagnetische bandcomponent (9) met gebruik van een overdraaginrichting volgens een der
5 voorgaande conclusies, waarbij de werkwijze de stappen omvat van:

het vasthouden van de bandcomponent (9) aan het eerste overdraagdeel (1) met de eerste magnetische aantrekkingskracht (F1);

10 het bewegen van het eerste overdraagdeel (1) en het tweede overdraagdeel (2, 102) ten opzichte van elkaar in de eerste overdraagtoestand aan weerszijden van het eerste overdraagvlak (P1);

15 het vasthouden van de bandcomponent (9) aan het tweede overdraagdeel (2, 102) met de tweede magnetische aantrekkingskracht (F2), waarbij in de eerste overdraagtoestand de tweede magnetische aantrekkingskracht (F2) bij het eerste overdraagvlak (P1) groter is dan de eerste magnetische aantrekkingskracht (F1) bij het eerste
20 overdraagvlak (P1); en

het overdragen van de bandcomponent (9) van het eerste overdraagdeel (1) naar het tweede overdraagdeel (2, 102),

25 waarbij in de eerste overdraagtoestand de tweede magneetveldreeks (22, 122, 222) ten minste gedeeltelijk verschoven is ten opzichte van de eerste magneetveldreeks (12, 212).

37. Werkwijze volgens conclusie 36, waarbij de werkwijze de stappen omvat van:

30 het ten opzichte van elkaar bewegen van het eerste overdraagdeel (1) en het tweede overdraagdeel (2, 102) van een pre-overdraagtoestand waarin het eerste overdraagdeel (1) en het tweede overdraagdeel (2, 102) op afstand van elkaar liggen aan weerszijden van het eerste
35 overdraagvlak (P1) op een eerste onderlinge afstand (Z1);

het ten opzichte van elkaar bewegen van het eerste overdraagdeel (1) en het tweede overdraagdeel (2,

102) van pre-overdraagtoestand naar de eerste
 overdraagtoestand waarin het eerste overdraagdeel (1) en
 het tweede overdraagdeel (2, 102) op afstand van elkaar
 liggen aan weerszijden van het eerste overdraagvlak (P1) op
 5 een tweede onderlinge afstand (Z2) die kleiner is dan de
 eerste onderlinge afstand (Z1); en

het ten opzichte van elkaar bewegen van het
 eerste overdraagdeel (1) en het tweede overdraagdeel (2,
 102) van de eerste overdraagtoestand naar een post-
 10 overdraagtoestand waarin het eerste overdraagdeel (1) en
 het tweede overdraagdeel (2, 102) op afstand van elkaar
 liggen aan weerszijden van het eerste overdraagvlak (P1) op
 een derde onderlinge afstand (Z3) die groter is dan de
 tweede onderlinge afstand (Z2),

15 waarbij de tweede magneetveldreeks (22, 122, 222)
 tenminste gedeeltelijk verschoven is ten opzichte van de
 eerste magneetveldreeks (12, 212) in de pre-
 overdraagtoestand, de eerste overdraagtoestand, de post-
 overdraagtoestand en daartussenin.

-o-o-o-o-o-o-o-o-o-

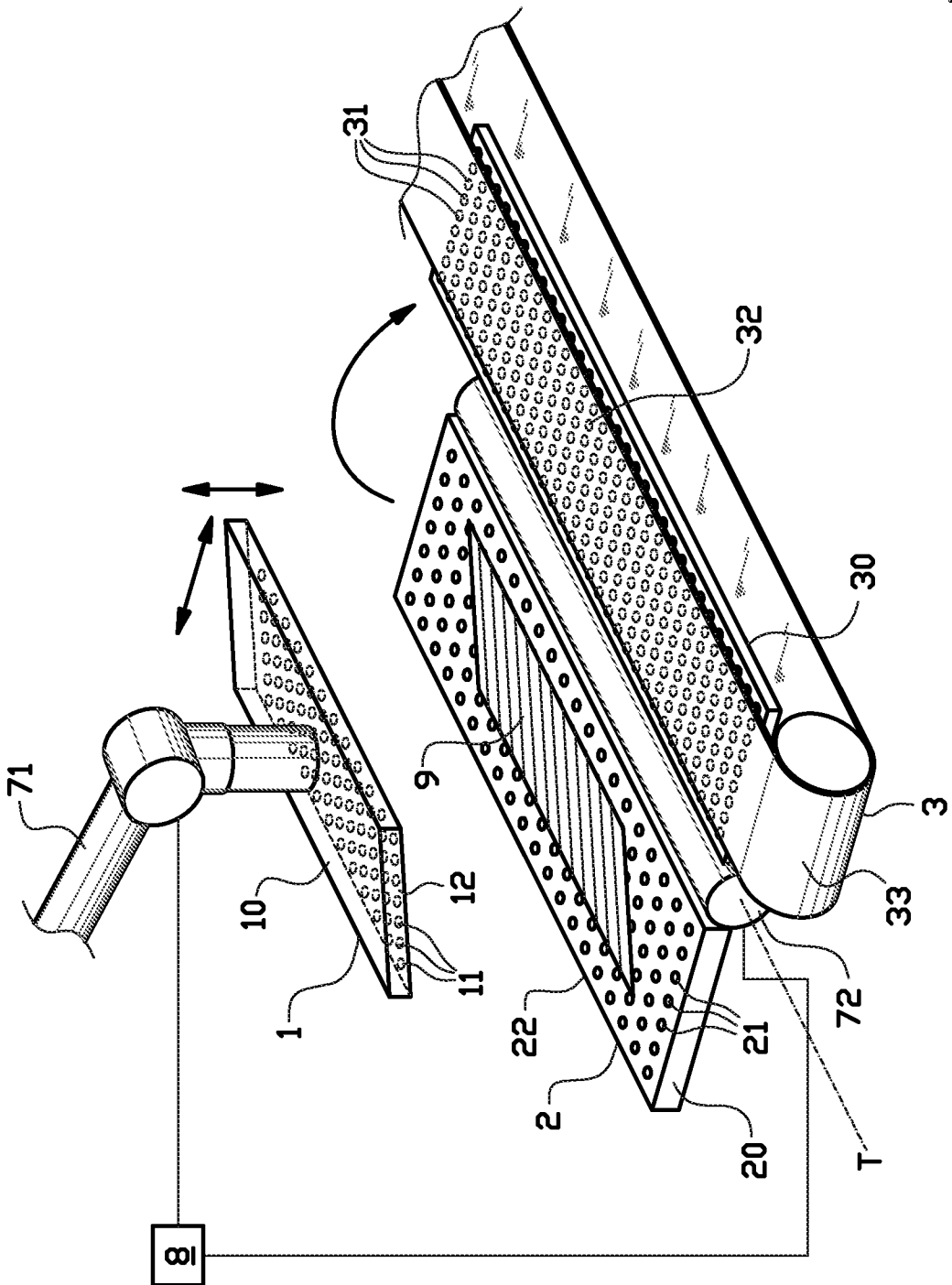

FIG. 1

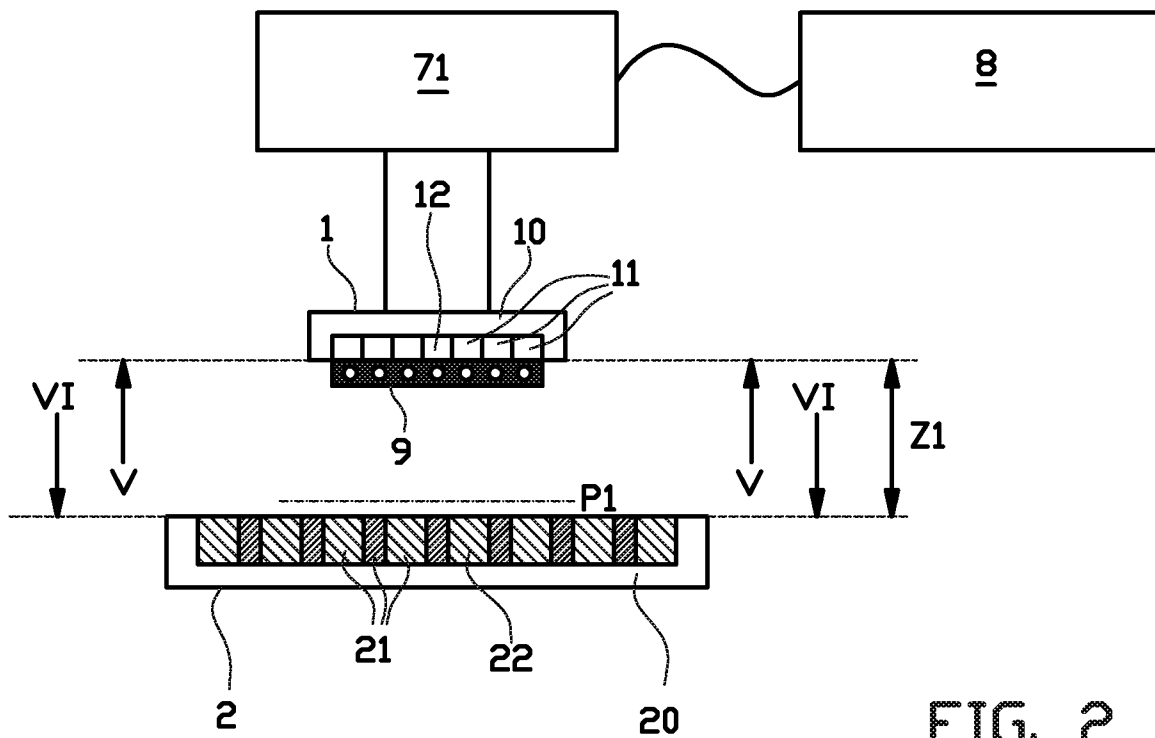

FIG. 2

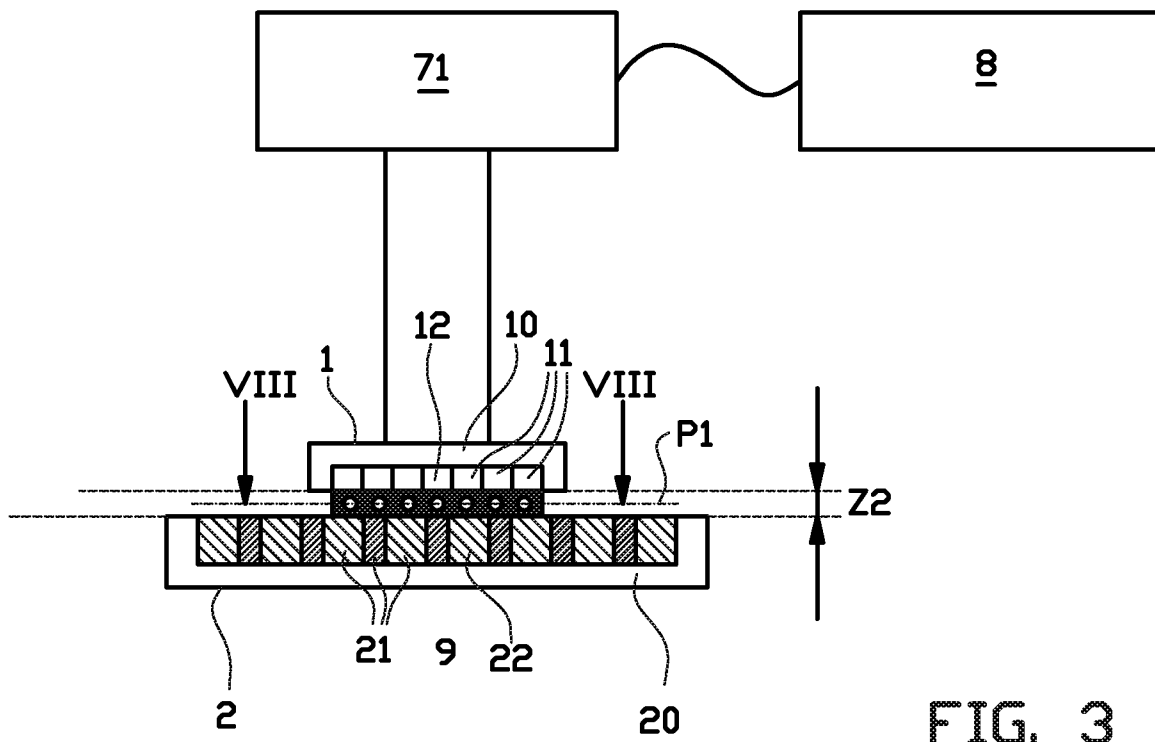

FIG. 3

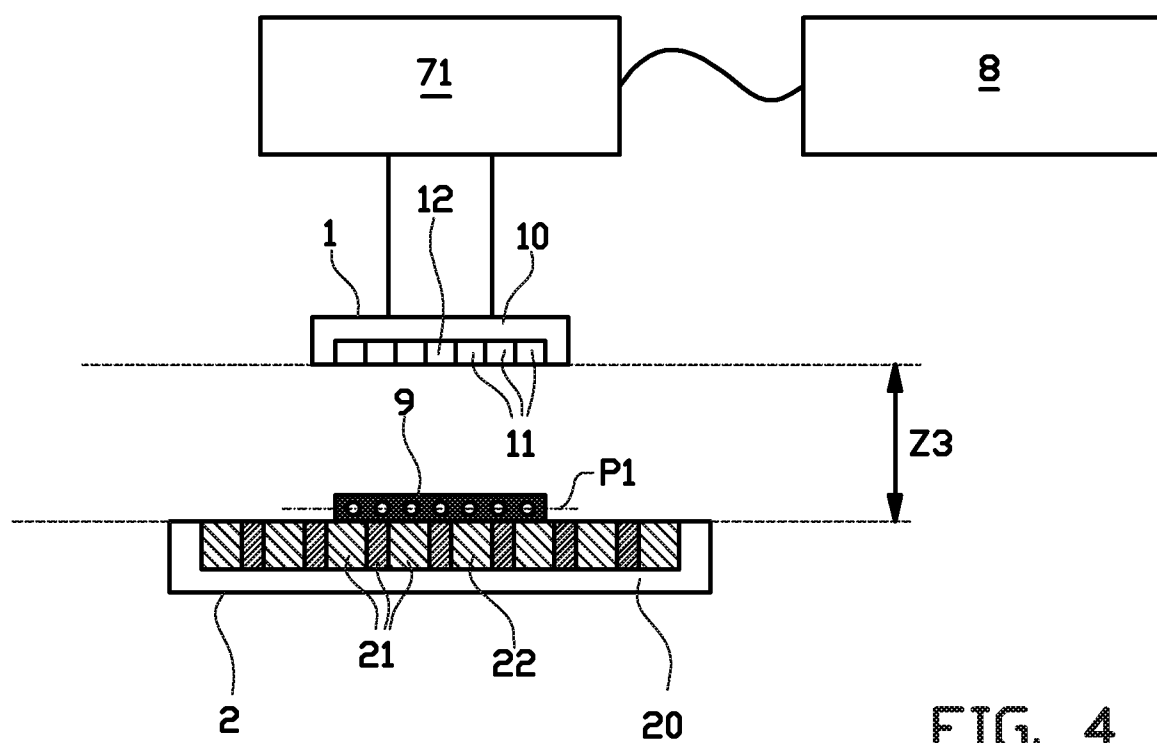

FIG. 4

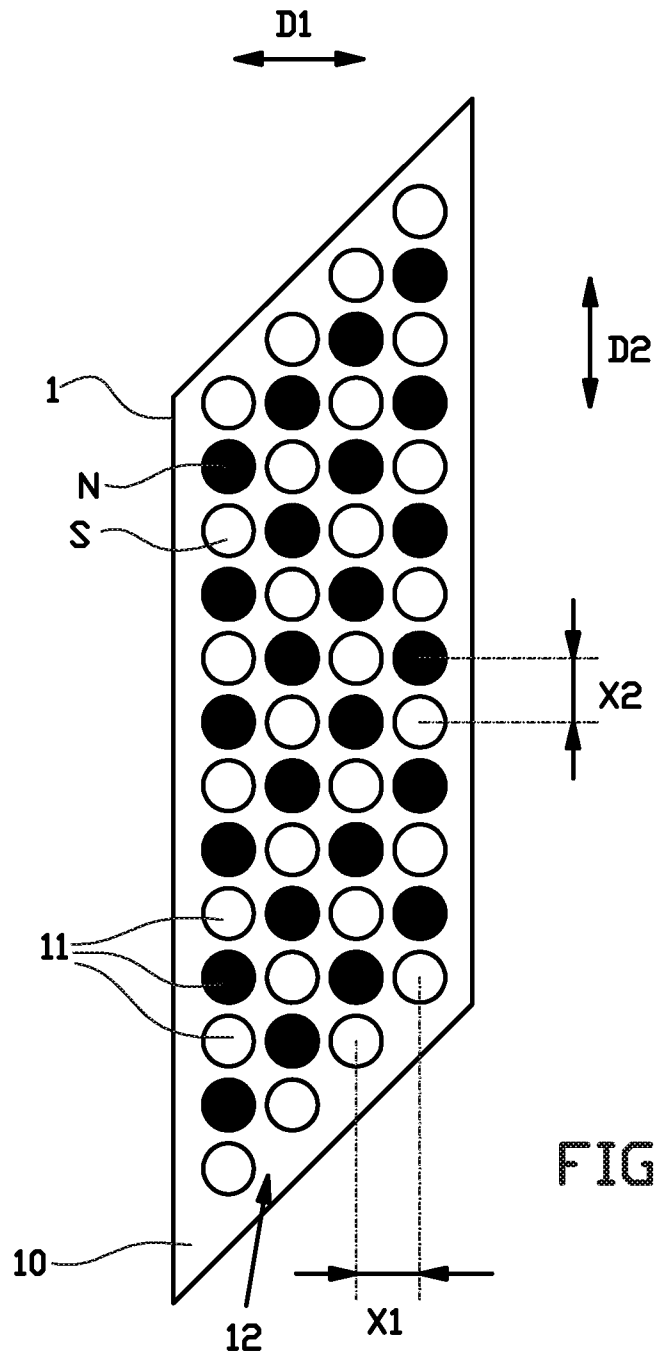

FIG. 5

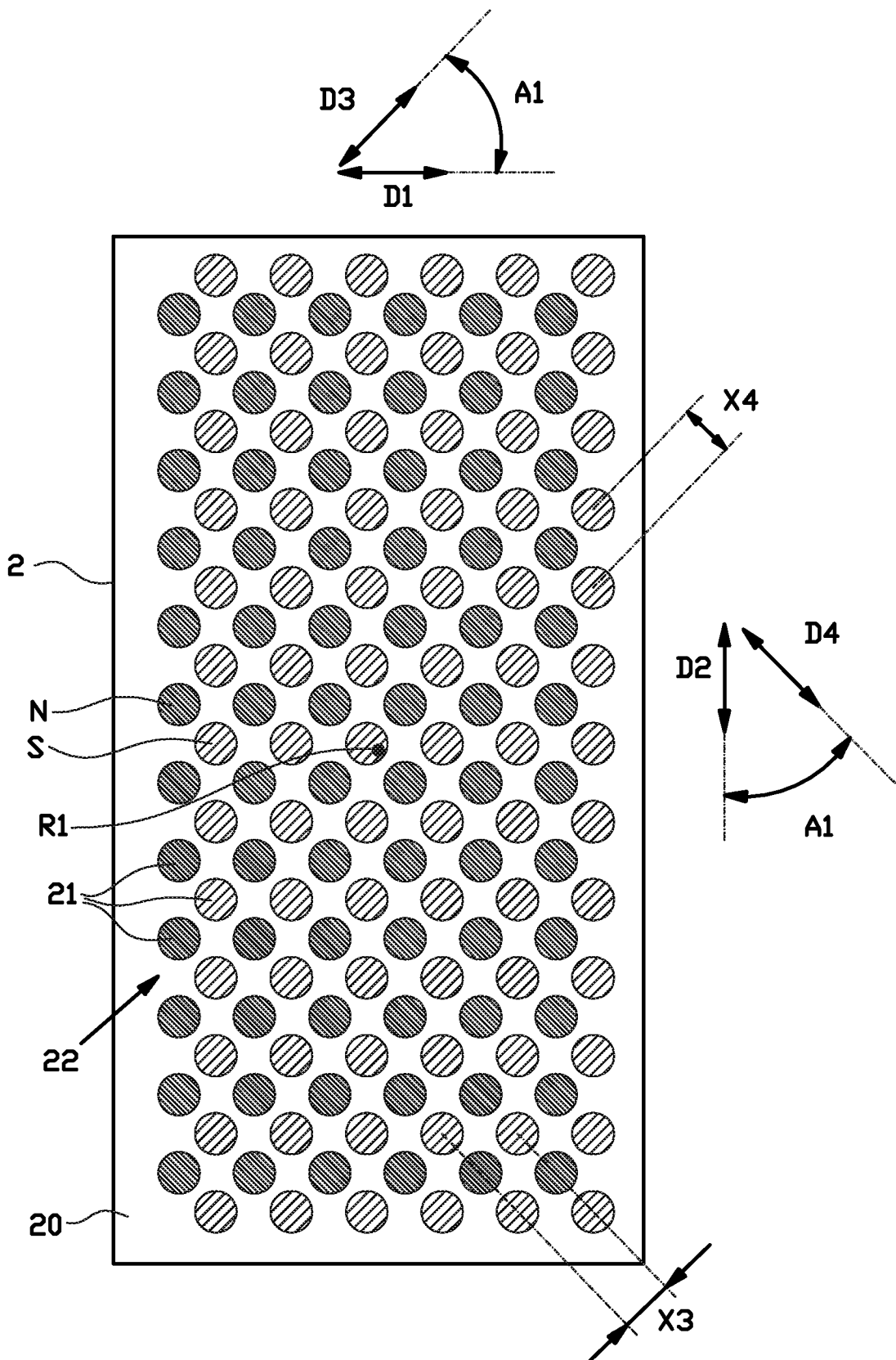

FIG. 6

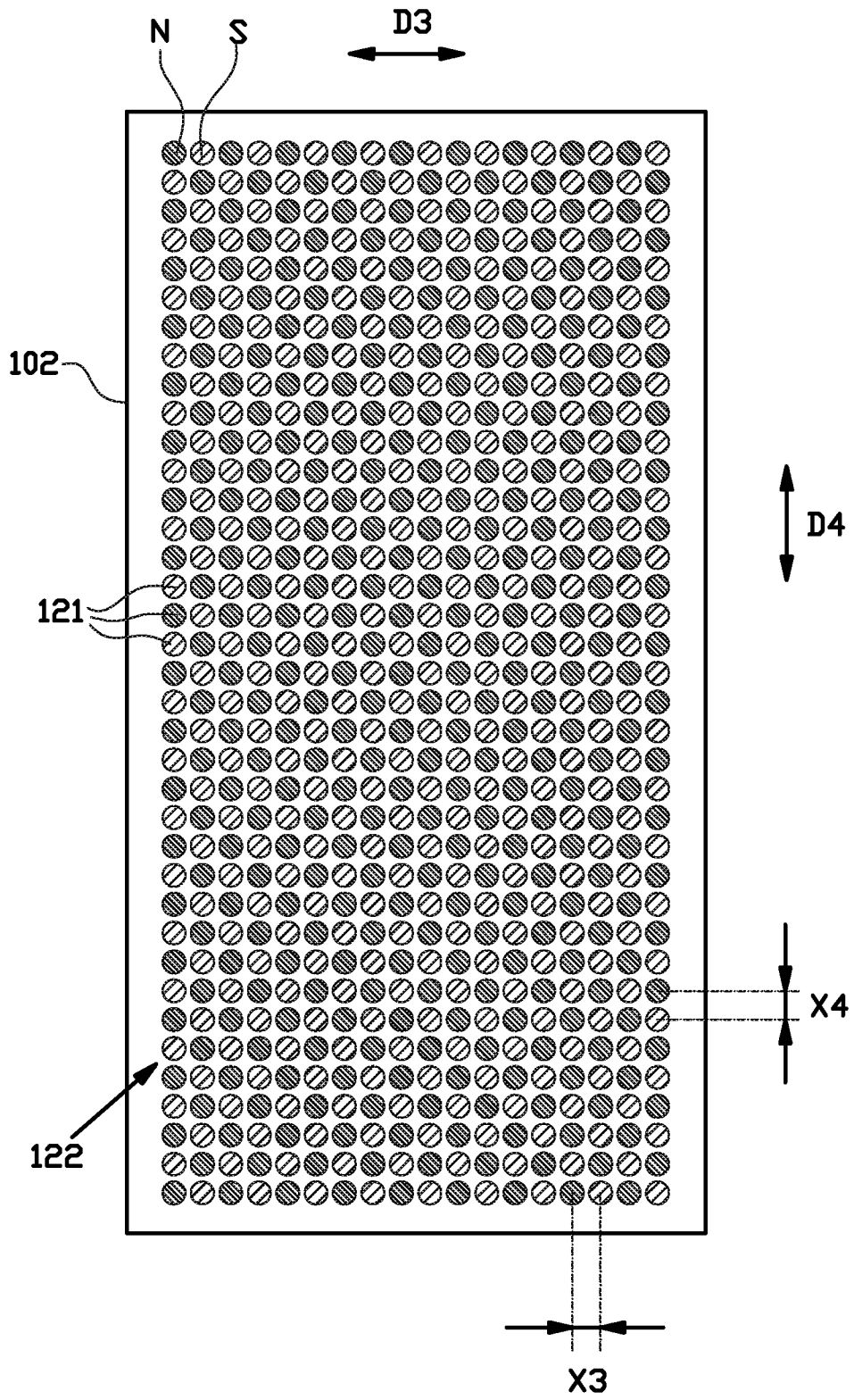

FIG. 7

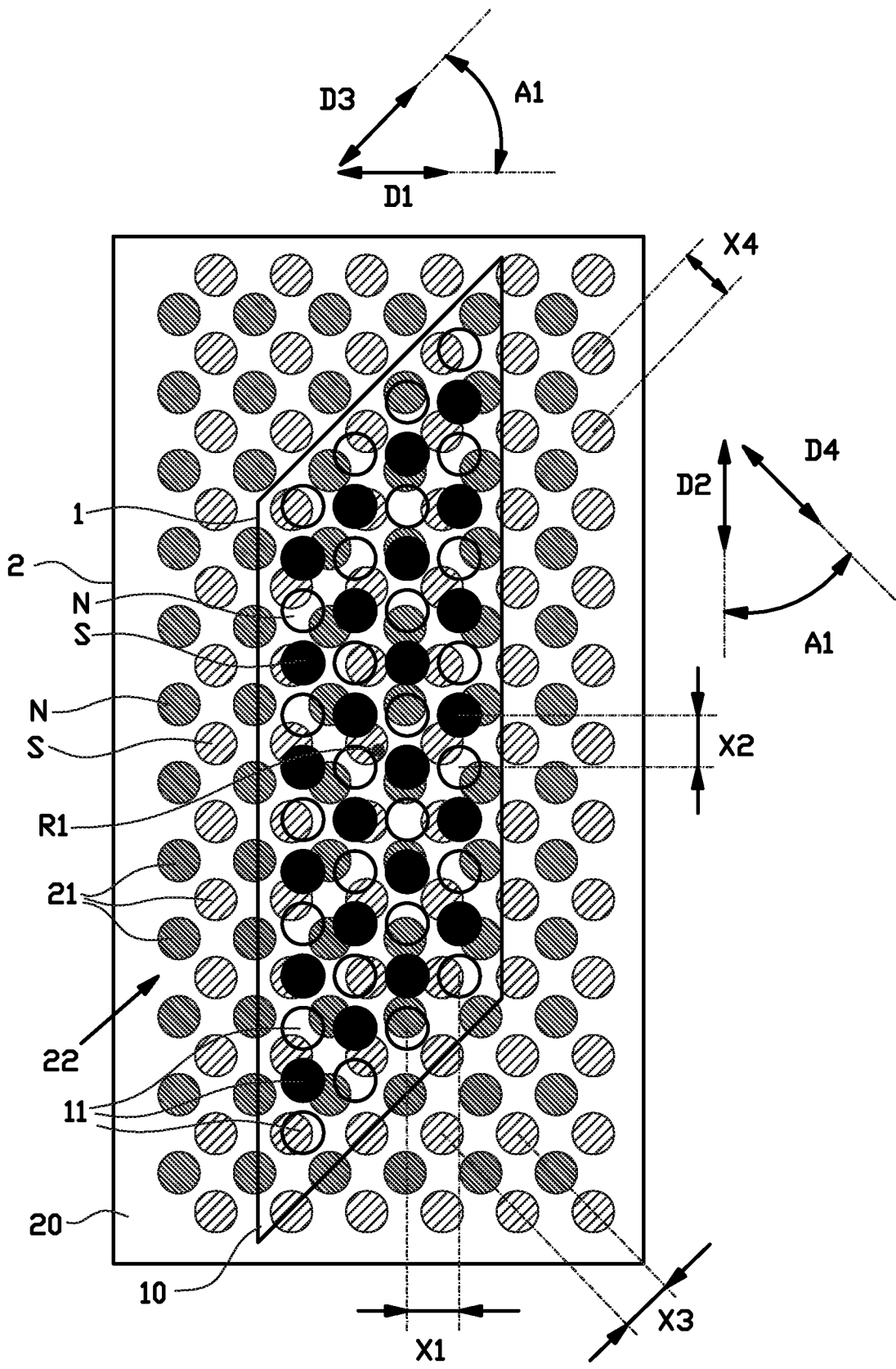

FIG. 8

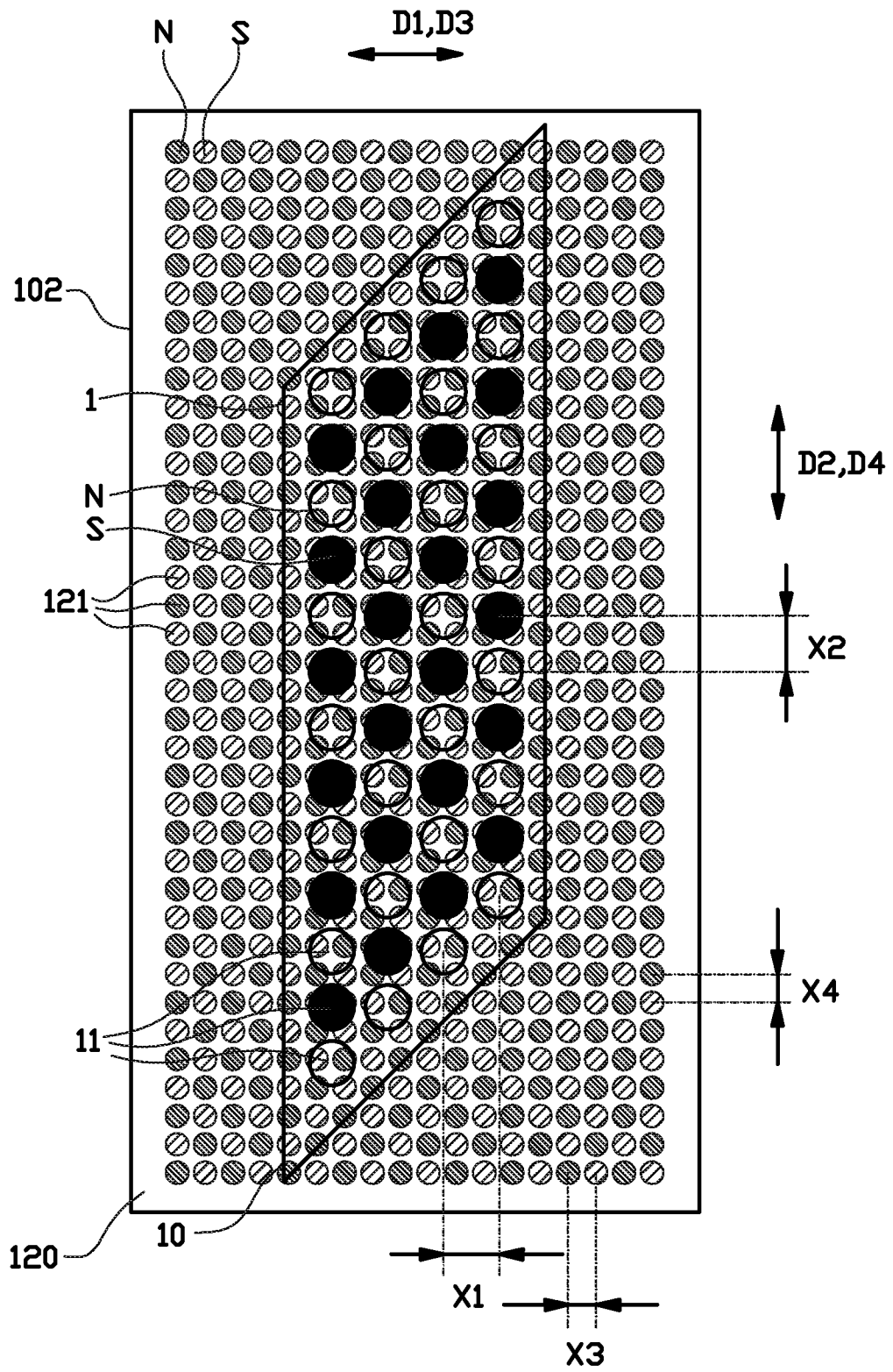

FIG. 9

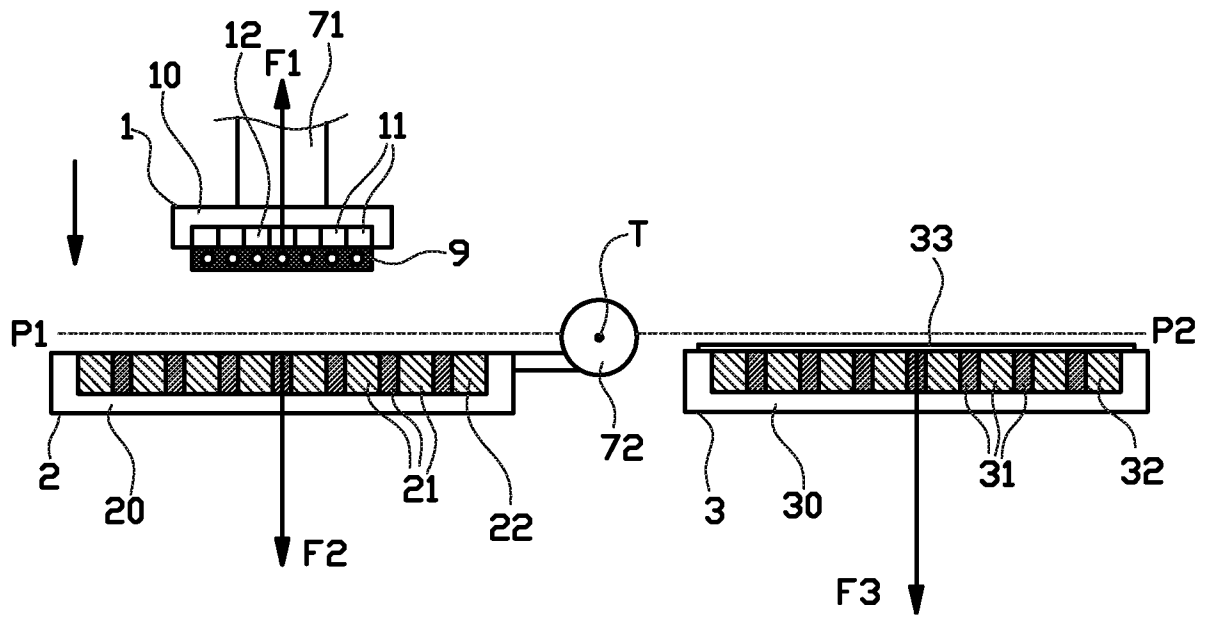

FIG. 10A

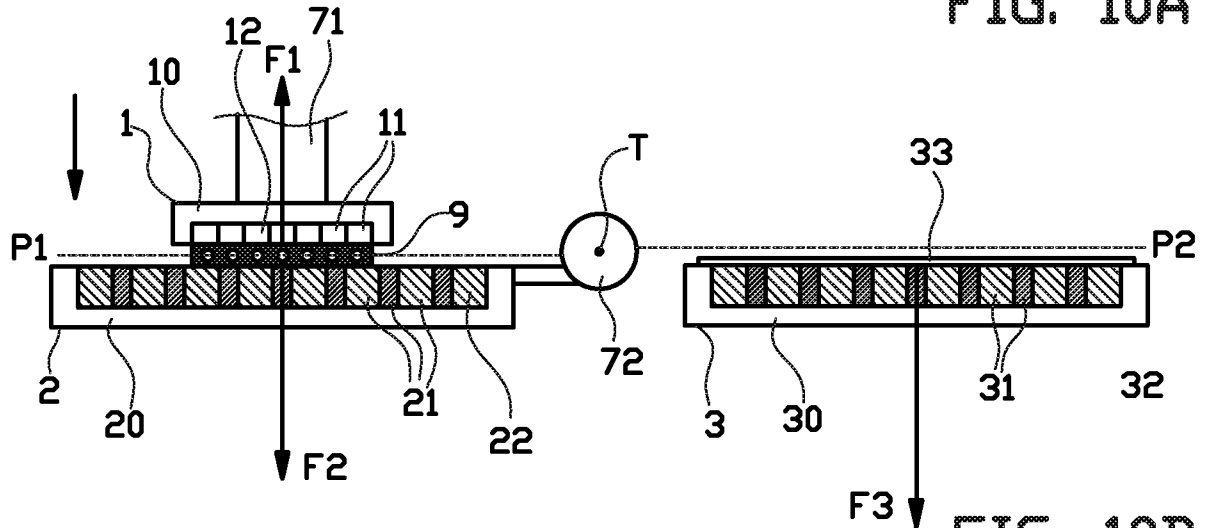

FIG. 10B

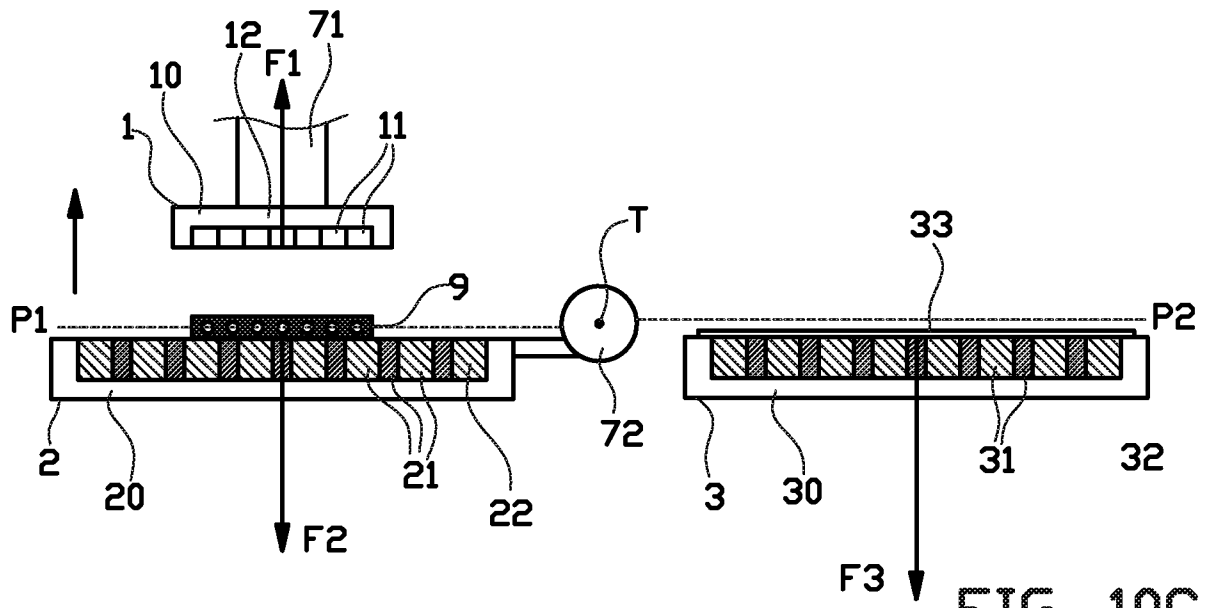

FIG. 10C

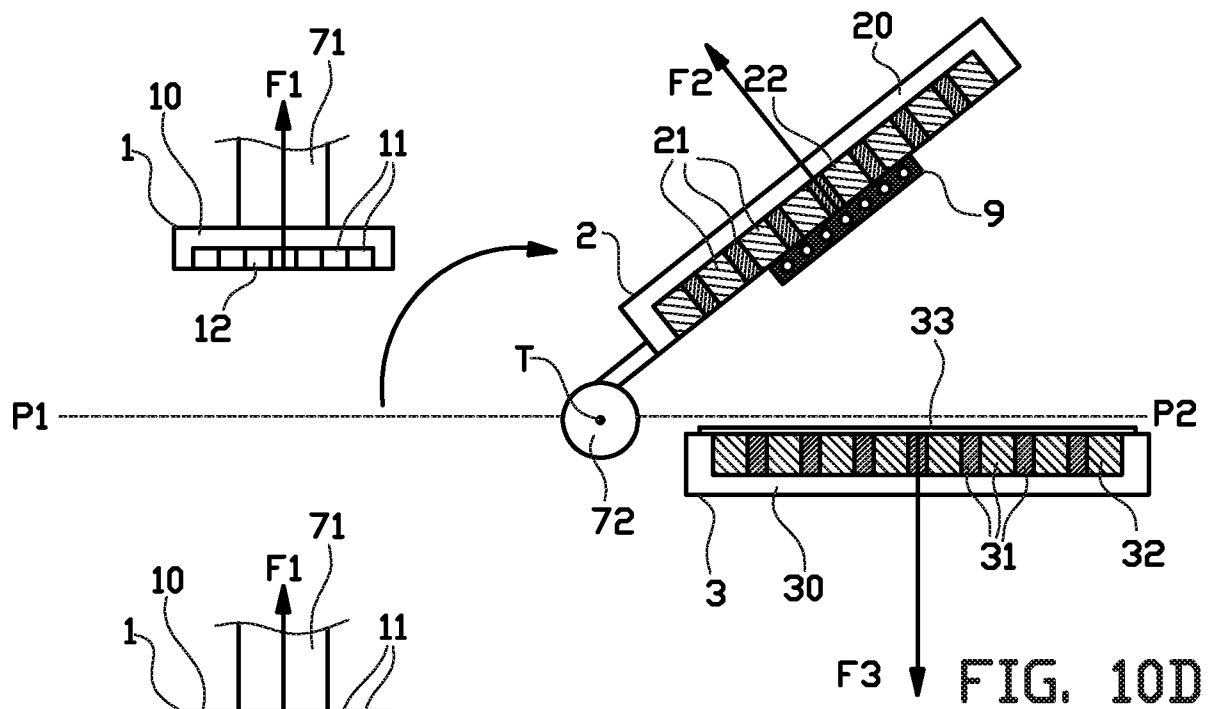

FIG. 10D

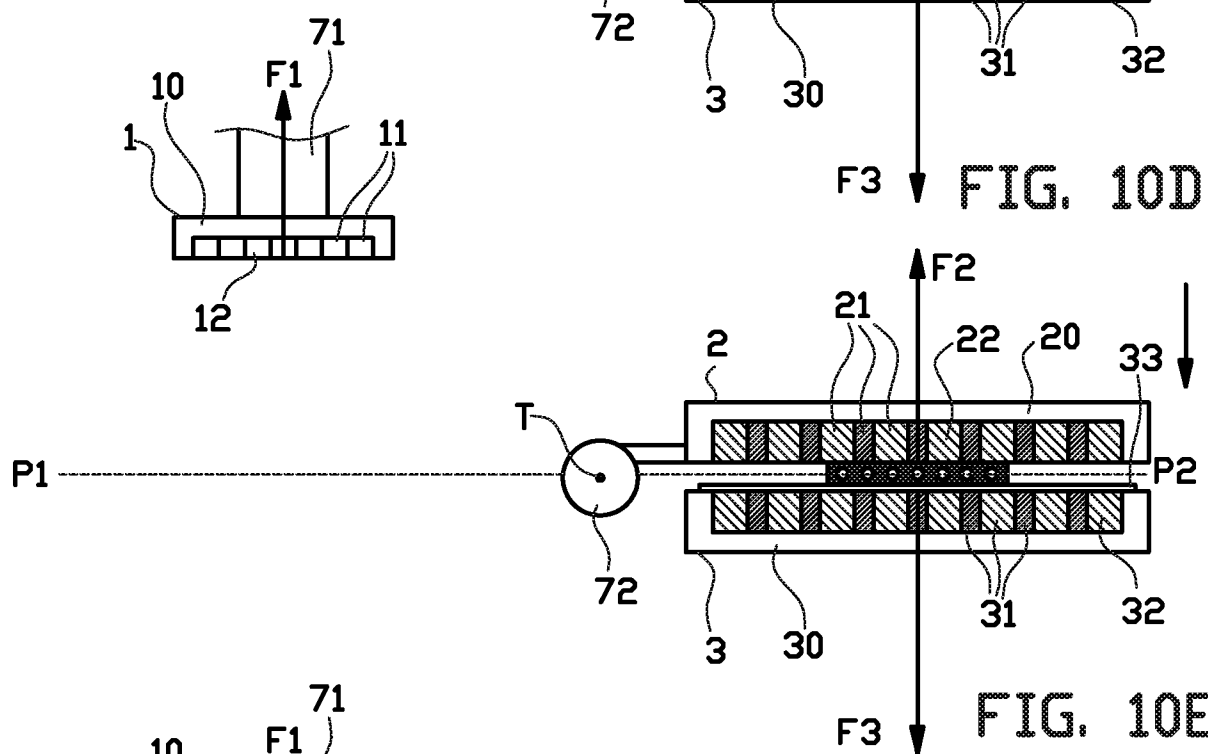

FIG. 10E

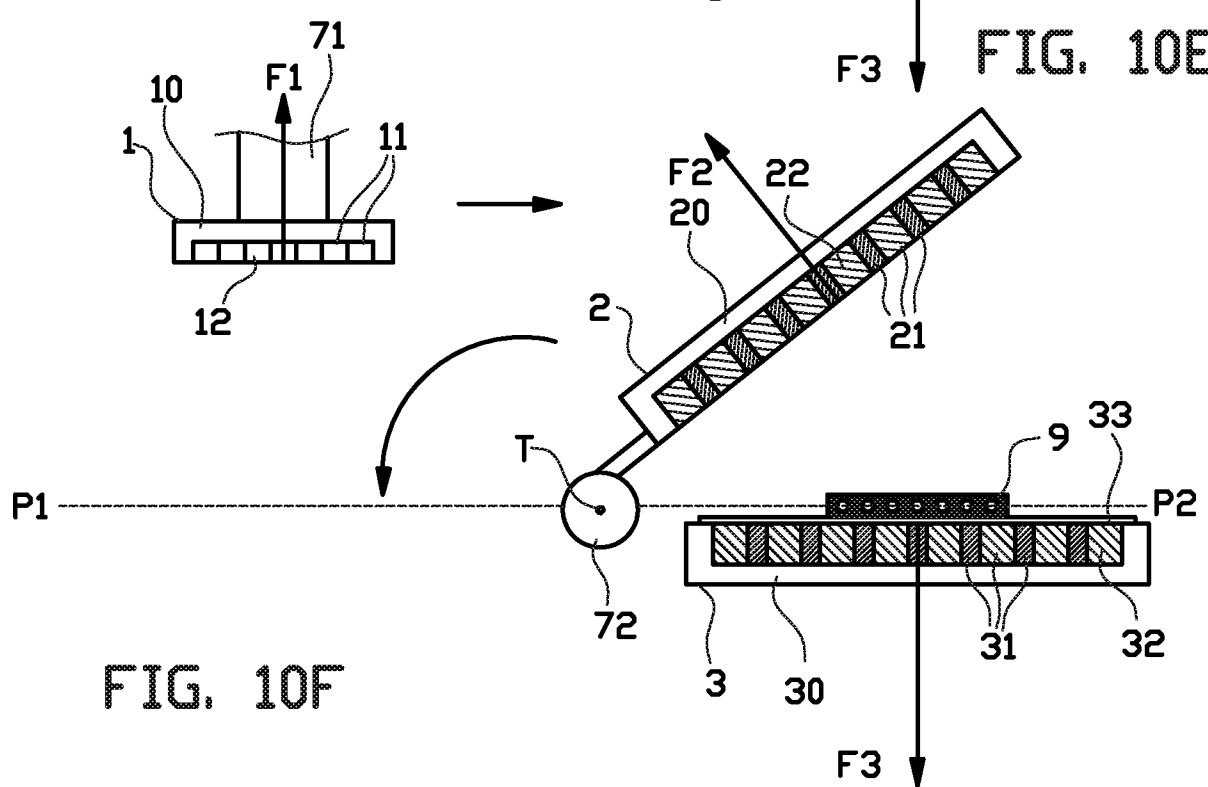
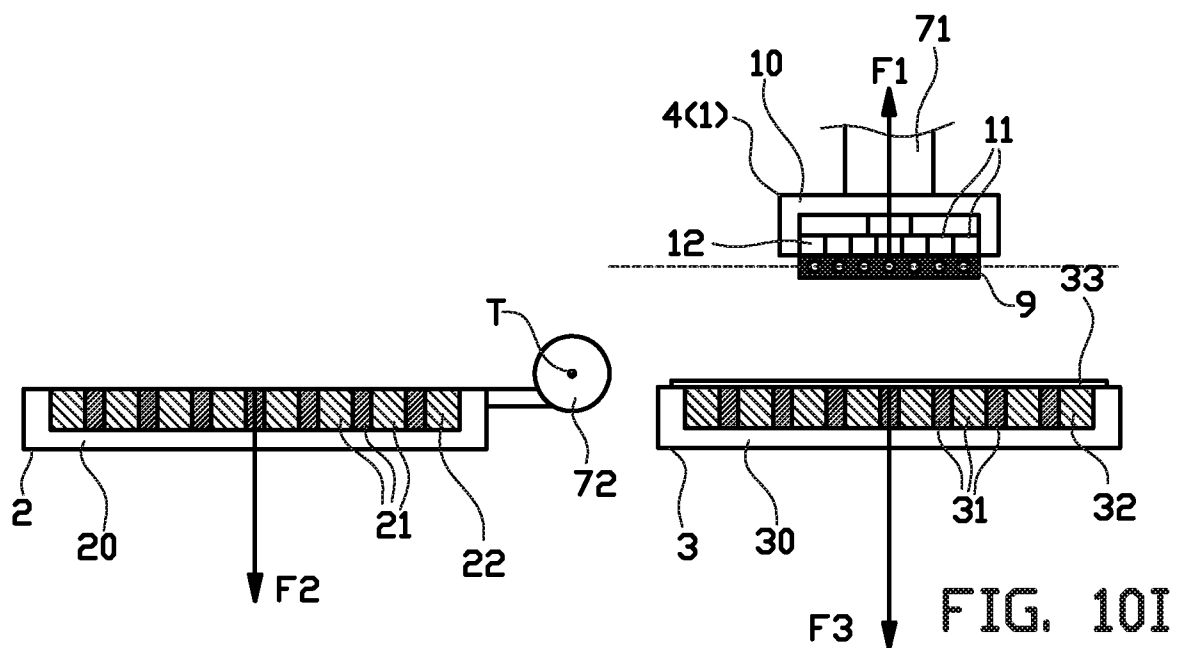
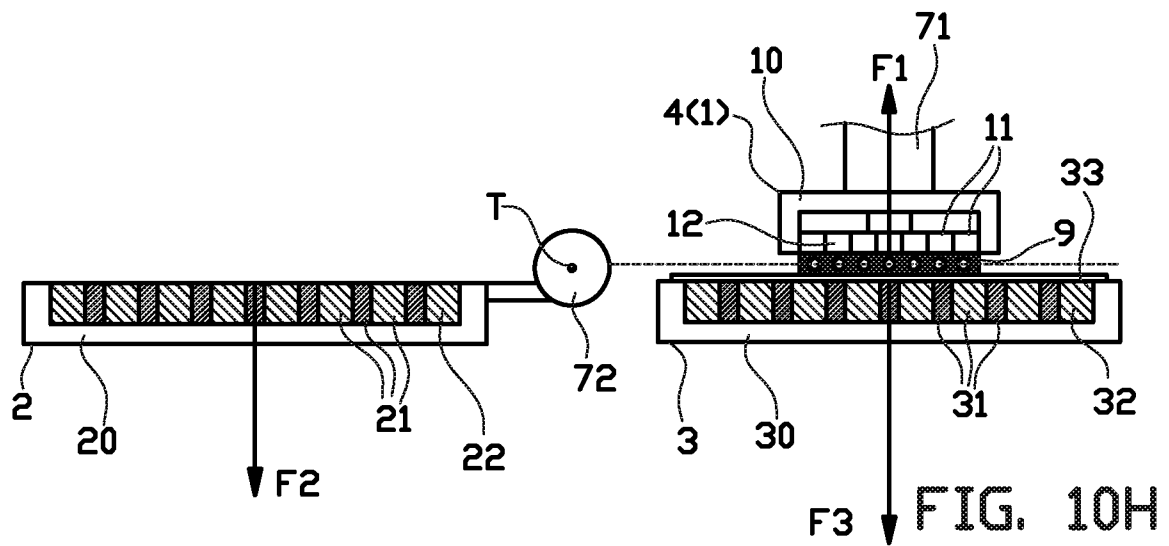
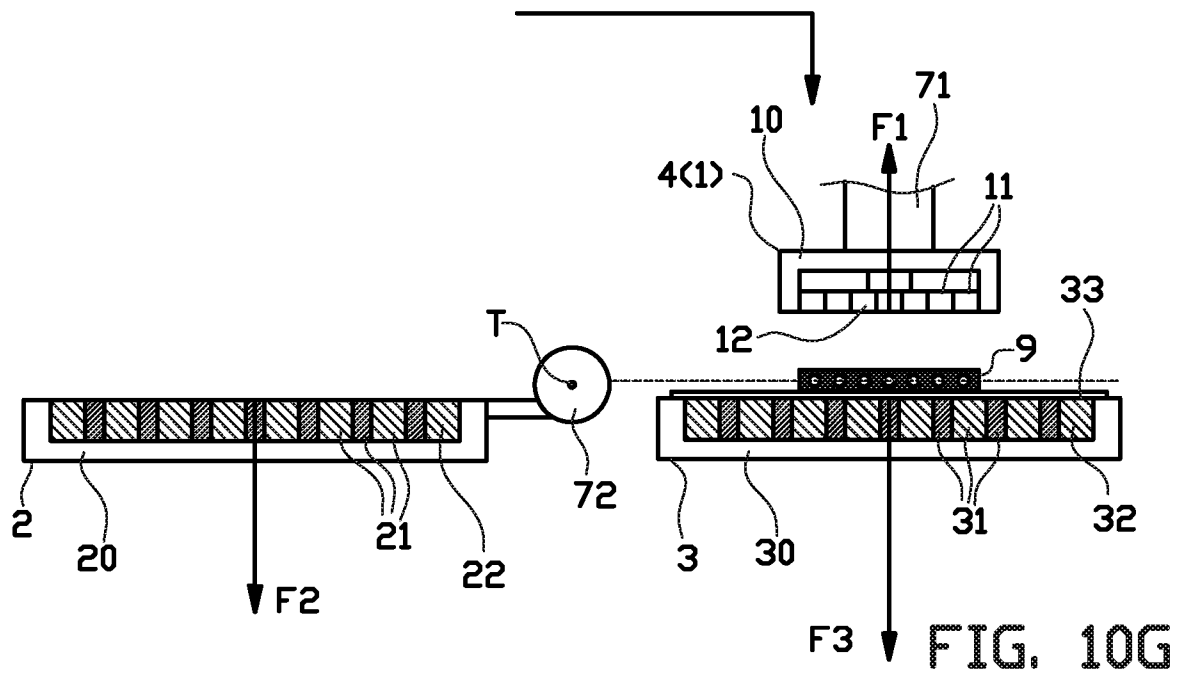

FIG. 10F



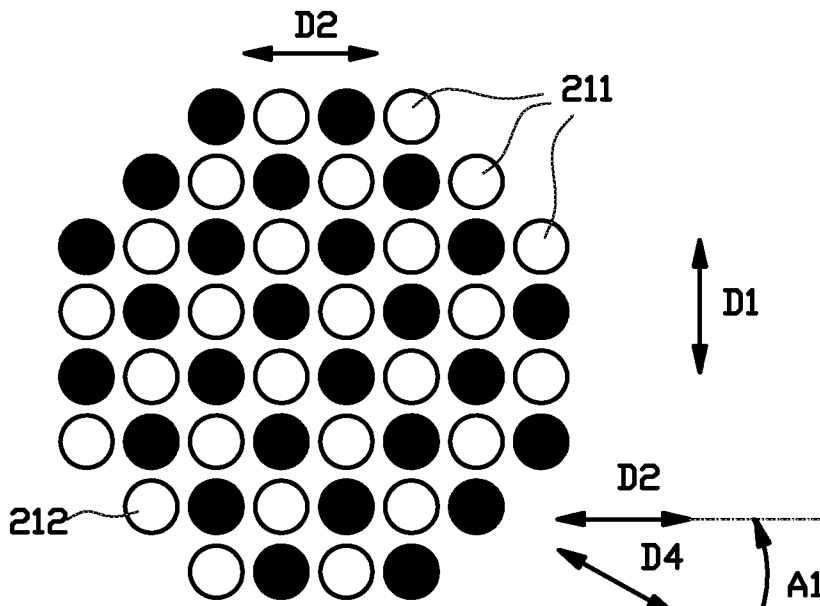

FIG. 11

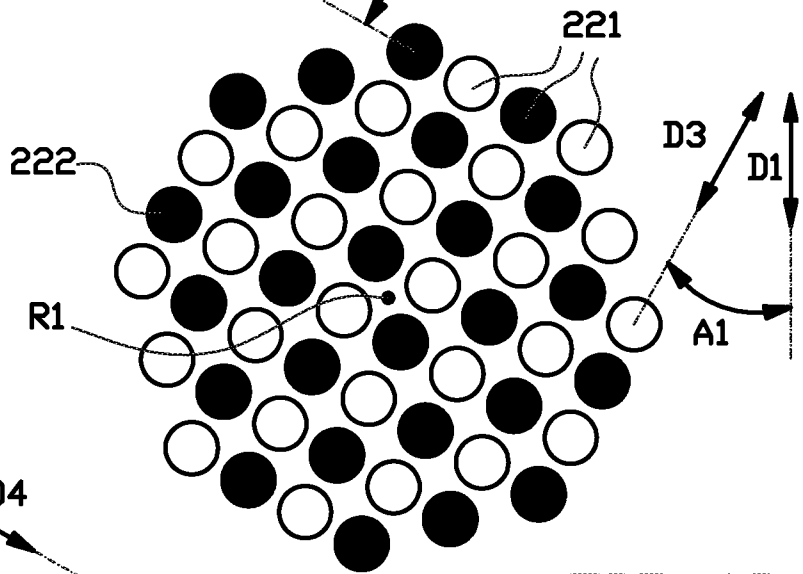

FIG. 12

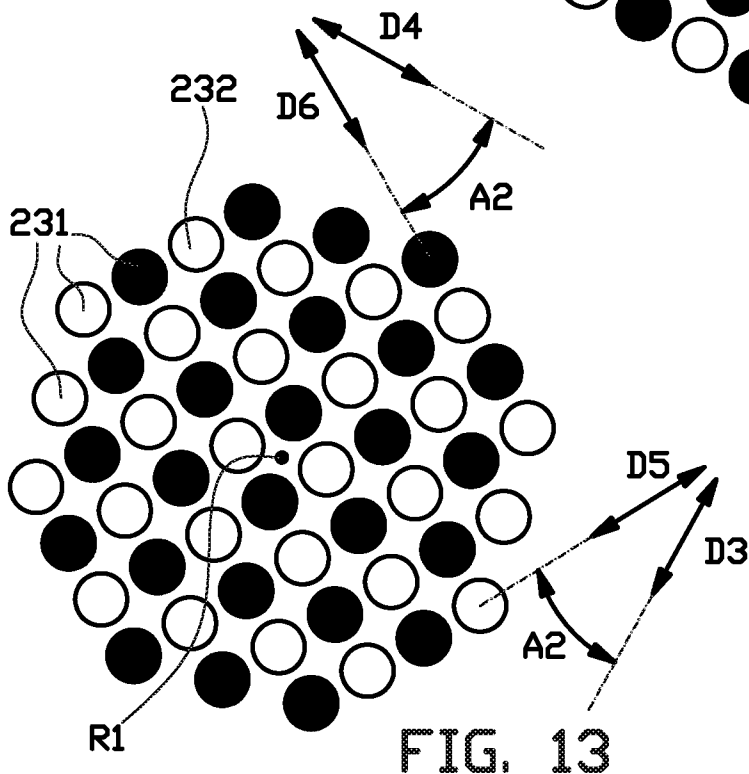

FIG. 13

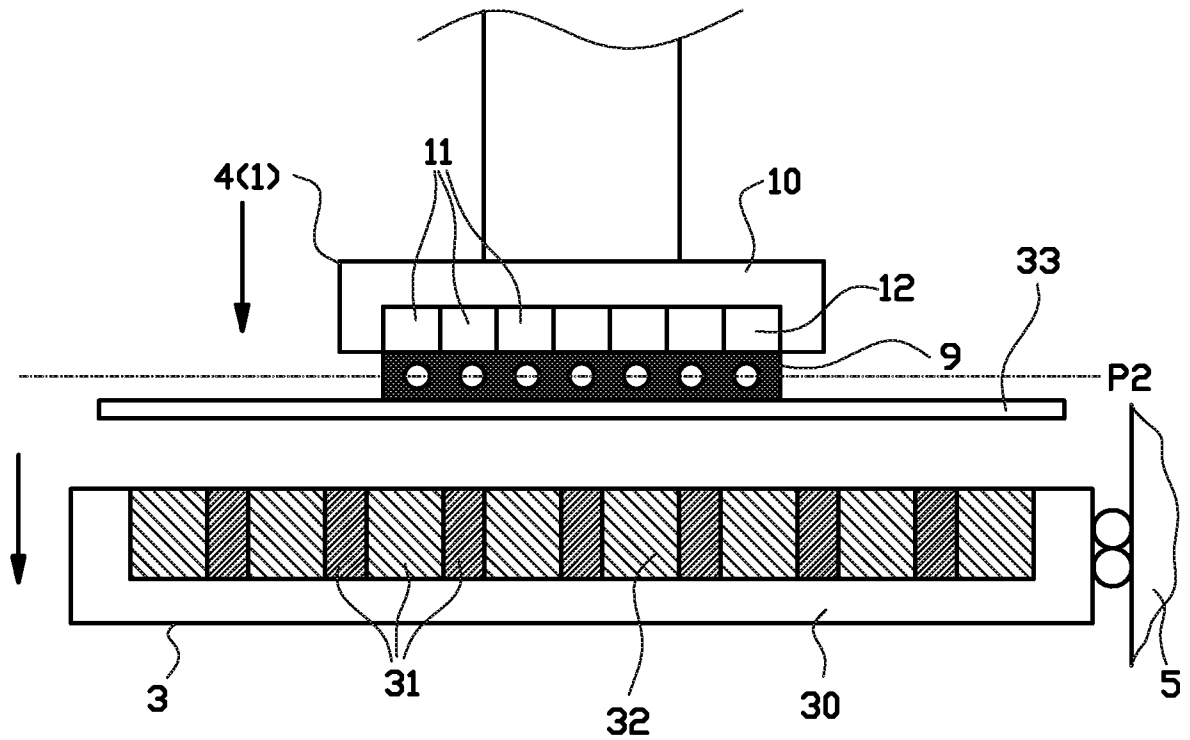

FIG. 14A

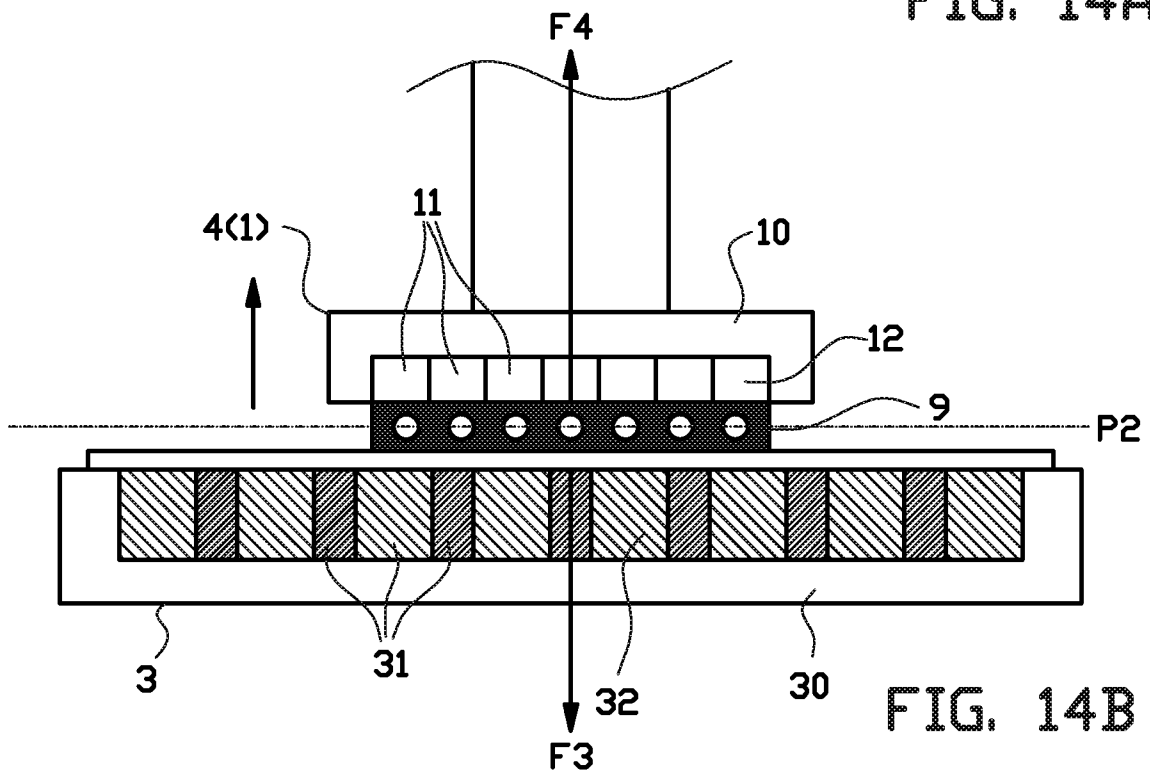

FIG. 14B

A B S T R A C T

The invention relates to a transfer device and method for transferring an at least partially ferromagnetic tire component (9), wherein transfer device comprises a first transfer member (1) and a second transfer member (2) which are movable into a first transfer state on opposite sides of a first transfer plane (P1), wherein the first transfer member (1) comprises first magnetic field sources (11) that form a first magnetic field array (12) for retaining the tire component (9) with a first magnetic attraction force (F1), wherein the second transfer member (2) comprises second magnetic field sources (21) that form a second magnetic field array (22) for retaining the tire component (9) with a second magnetic attraction force (F2) that is larger than the first magnetic attraction force (F1) at the first transfer plane (P1), wherein in the first transfer state the second magnetic field array (22) is offset with respect to the first magnetic field array (12).

SAMENWERKINGSVERDRAG (PCT)

RAPPORT BETREFFENDE NIEUWHEIDSONDERZOEK VAN INTERNATIONAAL TYPE

IDENTIFICATIE VAN DE NATIONALE AANVRAGE	KENMERK VAN DE AANVRAGER OF VAN DE GEMACHTIGDE
	NLP200590A
Nederlands aanvraag nr.	Indieningsdatum
2018380	15-02-2017
	Ingeroepen voorrangdatum
Aanvrager (Naam)	
VMI Holland B.V.	
Datum van het verzoek voor een onderzoek van internationaal type	Door de instantie voor Internationaal Onderzoek aan het verzoek voor een onderzoek van internationaal type toegekend nr.
08-04-2017	SN68705
I. CLASSIFICATIE VAN HET ONDERWERP (bij toepassing van verschillende classificaties, alle classificatiesymbolen opgeven)	
Volgens de internationale classificatie (IPC)	
B29D30/44;B25J15/06	
II. ONDERZOCHE GEBIEDEN VAN DE TECHNIEK	
Onderzochte minimumdocumentatie	
Classificatiesysteem	Classificatiesymbolen
IPC	B29D;B25J
Onderzochte andere documentatie dan de minimum documentatie, voor zover dergelijke documenten in de onderzochte gebieden zijn opgenomen	
III. <input type="checkbox"/>	GEEN ONDERZOEK MOGELIJK VOOR BEPAALDE CONCLUSIES (opmerkingen op aanvullingsblad)
IV. <input type="checkbox"/>	GEBREK AAN EENHEID VAN UITVINDING (opmerkingen op aanvullingsblad)

**ONDERZOEKSRAPPORT BETREFFENDE HET
RESULTAAT VAN HET ONDERZOEK NAAR DE STAND
VAN DE TECHNIEK VAN HET INTERNATIONALE TYPE**

Nummer van het verzoek om een onderzoek naar
de stand van de techniek

NL 2018380

<p>A. CLASSIFICATIE VAN HET ONDERWERP INV. B29D30/44 B25J15/06 ADD.</p>																	
<p>Volgens de internationale Classificatie van octrooien (IPC) of zowel volgens de nationale classificatie als volgens de IPC.</p>																	
<p>B. ONDERZOCHETE GEBIEDEN VAN DE TECHNIEK</p> <p>Onderzochte minimum documentatie (classificatie gevolgd door classificatiesymbolen) B29D B25J</p> <p>Onderzochte andere documentatie dan de minimum documentatie, voor dergelijke documenten, voor zover dergelijke documenten in de onderzochte gebieden zijn opgenomen</p> <p>Tijdens het onderzoek geraadpleegde elektronische gegevensbestanden (naam van de gegevensbestanden en, waar uitvoerbaar, gebruikte trefwoorden) EPO-Internal</p>																	
<p>C. VAN BELANG GEACHTE DOCUMENTEN</p> <table border="1"> <thead> <tr> <th>Categorie *</th> <th>Geciteerde documenten, eventueel met aanduiding van speciaal van belang zijnde passages</th> <th>Van belang voor conclusie nr.</th> </tr> </thead> <tbody> <tr> <td>A</td> <td>US 2011/315516 A1 (RAVAT STEPHANE [FR] ET AL) 29 december 2011 (2011-12-29) * alinea [0021] - alinea [0042]; figuren 1-4 *</td> <td>1-37</td> </tr> <tr> <td>A,D</td> <td>US 4 411 724 A (ITO TAIZO [JP] ET AL) 25 oktober 1983 (1983-10-25) in de aanvraag genoemd * kolom 3, regel 11 - regel 22 * * kolom 3, regel 46 - kolom 7, regel 46; figuren 1-12 *</td> <td>1-37</td> </tr> <tr> <td>A</td> <td>US 4 504 337 A (ASKAM JOHN F [GB] ET AL) 12 maart 1985 (1985-03-12) * kolom 2, regel 36 - kolom 5, regel 25; figuren 1-13 *</td> <td>1-37</td> </tr> <tr> <td></td> <td style="text-align: center;">----- -/-</td> <td></td> </tr> </tbody> </table>			Categorie *	Geciteerde documenten, eventueel met aanduiding van speciaal van belang zijnde passages	Van belang voor conclusie nr.	A	US 2011/315516 A1 (RAVAT STEPHANE [FR] ET AL) 29 december 2011 (2011-12-29) * alinea [0021] - alinea [0042]; figuren 1-4 *	1-37	A,D	US 4 411 724 A (ITO TAIZO [JP] ET AL) 25 oktober 1983 (1983-10-25) in de aanvraag genoemd * kolom 3, regel 11 - regel 22 * * kolom 3, regel 46 - kolom 7, regel 46; figuren 1-12 *	1-37	A	US 4 504 337 A (ASKAM JOHN F [GB] ET AL) 12 maart 1985 (1985-03-12) * kolom 2, regel 36 - kolom 5, regel 25; figuren 1-13 *	1-37		----- -/-	
Categorie *	Geciteerde documenten, eventueel met aanduiding van speciaal van belang zijnde passages	Van belang voor conclusie nr.															
A	US 2011/315516 A1 (RAVAT STEPHANE [FR] ET AL) 29 december 2011 (2011-12-29) * alinea [0021] - alinea [0042]; figuren 1-4 *	1-37															
A,D	US 4 411 724 A (ITO TAIZO [JP] ET AL) 25 oktober 1983 (1983-10-25) in de aanvraag genoemd * kolom 3, regel 11 - regel 22 * * kolom 3, regel 46 - kolom 7, regel 46; figuren 1-12 *	1-37															
A	US 4 504 337 A (ASKAM JOHN F [GB] ET AL) 12 maart 1985 (1985-03-12) * kolom 2, regel 36 - kolom 5, regel 25; figuren 1-13 *	1-37															
	----- -/-																
<p><input checked="" type="checkbox"/> Verdere documenten worden vermeld in het vervolg van vak C. <input checked="" type="checkbox"/> Leden van dezelfde octrooifamilie zijn vermeld in een bijlage</p>																	
<p>* Speciale categorieën van aangehaalde documenten</p> <p>"A" niet tot de categorie X of Y behorende literatuur die de stand van de techniek beschrijft</p> <p>"D" in de octrooiaanvraag vermeld</p> <p>"E" eerdere octrooi(aanvraag), gepubliceerd op of na de indieningsdatum, waarin dezelfde uitvinding wordt beschreven</p> <p>"L" om andere redenen vermelde literatuur</p> <p>"O" niet-schriftelijke stand van de techniek</p> <p>"P" tussen de voorrangsdatum en de indieningsdatum gepubliceerde literatuur</p> <p>"T" na de indieningsdatum of de voorrangsdatum gepubliceerde literatuur die niet bezwarend is voor de octrooiaanvraag, maar wordt vermeld ter verheldering van de theorie of het principe dat ten grondslag ligt aan de uitvinding</p> <p>"X" de conclusie wordt als niet nieuw of niet inventief beschouwd ten opzichte van deze literatuur</p> <p>"Y" de conclusie wordt als niet inventief beschouwd ten opzichte van de combinatie van deze literatuur met andere geciteerde literatuur van dezelfde categorie, waarbij de combinatie voor de vakman voor de hand liggend wordt geacht</p> <p>"&" lid van dezelfde octrooifamilie of overeenkomstige octrooipublicatie</p>																	
<p>Datum waarop het onderzoek naar de stand van de techniek van internationaal type werd voltooid</p> <p>26 oktober 2017</p>		<p>Verzenddatum van het rapport van het onderzoek naar de stand van de techniek van internationaal type</p>															
<p>Naam en adres van de instantie</p> <p>European Patent Office, P.B. 5818 Patentlaan 2 NL - 2280 HV Rijswijk Tel. (+31-70) 340-2040 Fax: (+31-70) 340-3016</p>		<p>De bevoegde ambtenaar</p> <p>Fregosi, Alberto</p>															

1

**ONDERZOEKSRAPPORT BETREFFENDE HET
 RESULTAAT VAN HET ONDERZOEK NAAR DE STAND
 VAN DE TECHNIEK VAN HET INTERNATIONALE TYPE**

Nummer van het verzoek om een onderzoek naar
 de stand van de techniek

NL 2018380

C. (Vervolg). VAN BELANG GEACHTE DOCUMENTEN		
Categorie *	Geciteerde documenten, eventueel met aanduiding van speciaal van belang zijnde passages	Van belang voor conclusie nr.
A	US 6 695 949 B1 (JUNGK ANDREAS [DE] ET AL) 24 februari 2004 (2004-02-24) * kolom 8, regel 10 - kolom 10, regel 34; figuren 1a-2b *	1-37
A	----- US 2012/067516 A1 (DRUET MICHEL [FR] ET AL) 22 maart 2012 (2012-03-22) * alinea [0034] - alinea [0073]; figuren 1-9 *	1-37

**ONDERZOEKSRAPPORT BETREFFENDE HET
RESULTAAT VAN HET ONDERZOEK NAAR DE STAND
VAN DE TECHNIEK VAN HET INTERNATIONALE TYPE**

Informatie over leden van dezelfde octroofamilie

Nummer van het verzoek om een onderzoek naar
de stand van de techniek

NL 2018380

In het rapport genoemd octrooigescrift	Datum van publicatie	Overeenkomst(e) geschrift(en)	Datum van publicatie	
US 2011315516	A1	29-12-2011	BR P10920099 A2	15-12-2015
			CN 102196980 A	21-09-2011
			EP 2349893 A1	03-08-2011
			FR 2937625 A1	30-04-2010
			JP 5425918 B2	26-02-2014
			JP 2012506785 A	22-03-2012
			US 2011315516 A1	29-12-2011
			WO 2010049266 A1	06-05-2010
US 4411724	A	25-10-1983	JP S5855235 A	01-04-1983
			US 4411724 A	25-10-1983
US 4504337	A	12-03-1985	AU 2768584 A	15-11-1984
			DE 3417201 A1	15-11-1984
			ES 8506506 A1	16-11-1985
			FR 2546447 A1	30-11-1984
			IT 1174088 B	01-07-1987
			JP S59212239 A	01-12-1984
			NL 8401468 A	03-12-1984
			US 4504337 A	12-03-1985
			ZA 8403292 B	24-12-1985
			US 6695949	B1
CZ 20020437 A3	12-03-2003			
DE 19938149 A1	08-03-2001			
EP 1210224 A1	05-06-2002			
JP 2003507211 A	25-02-2003			
PT 1210224 E	29-10-2004			
SK 1952002 A3	05-08-2003			
US 6695949 B1	24-02-2004			
WO 0112423 A1	22-02-2001			
ZA 200201237 B	27-11-2002			
US 2012067516	A1	22-03-2012	BR P10923220 A2	26-01-2016
			CN 102245373 A	16-11-2011
			EP 2382083 A2	02-11-2011
			FR 2939780 A1	18-06-2010
			JP 2012511449 A	24-05-2012
			US 2012067516 A1	22-03-2012
			WO 2010066895 A2	17-06-2010

WRITTEN OPINION

File No. SN68705	Filing date (day/month/year) 15.02.2017	Priority date (day/month/year)	Application No. NL2018380
International Patent Classification (IPC) INV. B29D30/44 B25J15/06			
Applicant VMI Holland B.V.			

This opinion contains indications relating to the following items:

- Box No. I Basis of the opinion
- Box No. II Priority
- Box No. III Non-establishment of opinion with regard to novelty, inventive step and industrial applicability
- Box No. IV Lack of unity of invention
- Box No. V Reasoned statement with regard to novelty, inventive step or industrial applicability; citations and explanations supporting such statement
- Box No. VI Certain documents cited
- Box No. VII Certain defects in the application
- Box No. VIII Certain observations on the application

	Examiner Fregosi, Alberto
--	------------------------------

WRITTEN OPINION

Application number
NL2018380

Box No. I Basis of this opinion

1. This opinion has been established on the basis of the latest set of claims filed before the start of the search.
2. With regard to any **nucleotide and/or amino acid sequence** disclosed in the application and necessary to the claimed invention, this opinion has been established on the basis of:
 - a. type of material:
 - a sequence listing
 - table(s) related to the sequence listing
 - b. format of material:
 - on paper
 - in electronic form
 - c. time of filing/furnishing:
 - contained in the application as filed.
 - filed together with the application in electronic form.
 - furnished subsequently for the purposes of search.
3. In addition, in the case that more than one version or copy of a sequence listing and/or table relating thereto has been filed or furnished, the required statements that the information in the subsequent or additional copies is identical to that in the application as filed or does not go beyond the application as filed, as appropriate, were furnished.
4. Additional comments:

Box No. V Reasoned statement with regard to novelty, inventive step or industrial applicability; citations and explanations supporting such statement

1. Statement

Novelty	Yes: Claims	1-37
	No: Claims	
Inventive step	Yes: Claims	1-37
	No: Claims	
Industrial applicability	Yes: Claims	1-37
	No: Claims	
2. Citations and explanations
see separate sheet

Re Item V

Reasoned statement with regard to novelty, inventive step or industrial applicability; citations and explanations supporting such statement

1. State of the Art

Reference is made to the following documents:

D1 : US 2011/0315516 - A1;

D2 : US 4,411,724 - A;

D3 : US 4,504,337 - A;

D4 : US 6,695,949 - B1;

D5 : US 2012/0067516 - A1.

2. Claims 1 - 37 - Novelty and Inventive Step

2.1 Claim 1 relates to a transfer device for transferring an at least partially ferromagnetic tire component (9), wherein the transfer device comprises :

(a) - a first transfer member (1) and

(b) - a second transfer member (2),

which are movable relative to each other into a first transfer state on opposite sides of a first transfer plane,

(a1) - wherein the first transfer member (1) comprises a plurality of first magnetic field sources (11) that form a first magnetic field array for retaining the tire component to the first transfer member with a first magnetic attraction force;

(b1) - wherein the second transfer member (2) comprises a plurality of second magnetic field sources (21) that form a second magnetic field array for retaining the tire component to the second transfer member with a second magnetic attraction force;

(c) - wherein in the first transfer state the second magnetic attraction force at the first transfer plane is larger than the first magnetic attraction force at the first transfer plane to transfer the tire component from the first transfer member to the second transfer member;

(d) - wherein in the first transfer state the second magnetic field array is at least partially offset with respect to the first magnetic field array.

2.2 Transfer devices for transferring tire components containing at least partially ferromagnetic elements, the devices substantially comprising a first transfer member provided with magnetic field sources and a second transfer member provided with magnetic field sources, first and second transfer members being movable relative to each other, are well known in the field: see for instance documents **D3** (US 4,504,337 - A), **D4** (US 6,695,949 - B1), **D5** (US 2012/0067516 - A1).

2.3 Furthermore, both documents **D1** (US 2011/0315516 - A1) and **D2** (US 4,411,724 - A) describe the provision of altering the magnetic field arrays to achieve desired technical effects: see for instance paragraphs [0040] - [0042] of **D1** and column 3, lines 11-22 of **D2**.

2.4 However, none of said documents **D1** to **D5** (which are regarded as the state of the art nearest to the subject-matter of claim **1** of the present application), disclose, in combination, the additional feature **(d)** recited in claim **1**.

Claim **1** is therefore novel.

2.5 The problem to be solved is explained from page 1, line 28 to page 2, line 6 of the present application, namely to provide a transfer device of reduced complexity and cost in comparison with the prior art devices.

2.6 This problem is solved by the combination of features as recited in claim **1**. Because of the offset [feature **(d)**], the magnetic attraction force between the first transfer member and the second transfer member can be reduced significantly, thus allowing for an easy separation of the transfer members after the transfer, without the need for additional separation means or control of the magnetic attraction forces.

2.7 The specific problem underlying the present application has not been acknowledged by the available prior art; the solution proposed by claim **1** is neither known from, nor rendered obvious by the available prior art.

Claim **1** involves therefore an inventive step.

2.8 Independent claim **36** substantially recites a method of transferring a ferromagnetic tire component using the transfer device recited in claim **1** and, as such, is also regarded as novel and inventive.

2.9 The dependent claims **2** to **35** and **37**, as such, are also regarded as novel and inventive.
