



(No Model.)

3 Sheets—Sheet 2.

I. REENS.  
TAILOR'S TABLE.

No. 420,212.

Patented Jan. 28, 1890.

Fig. 2.

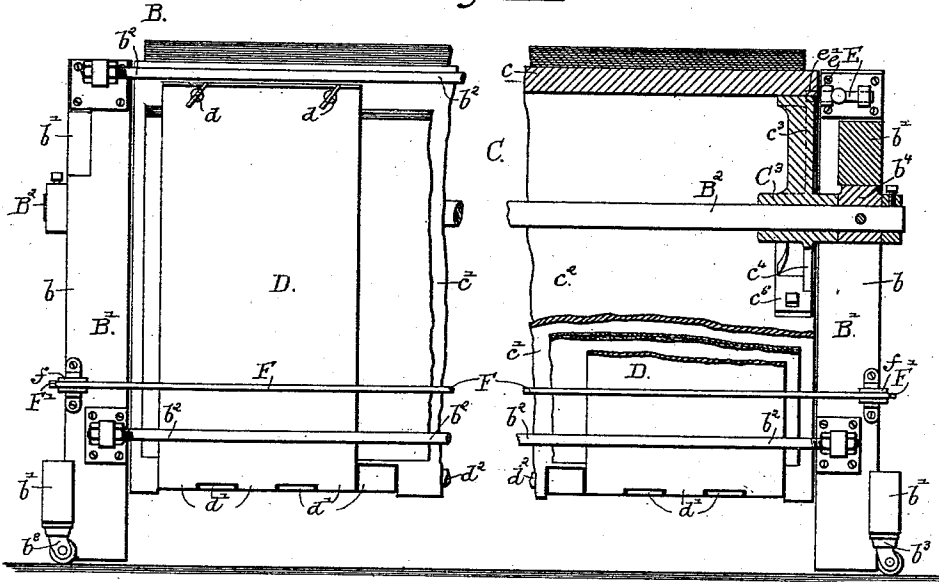

Fig. 3.

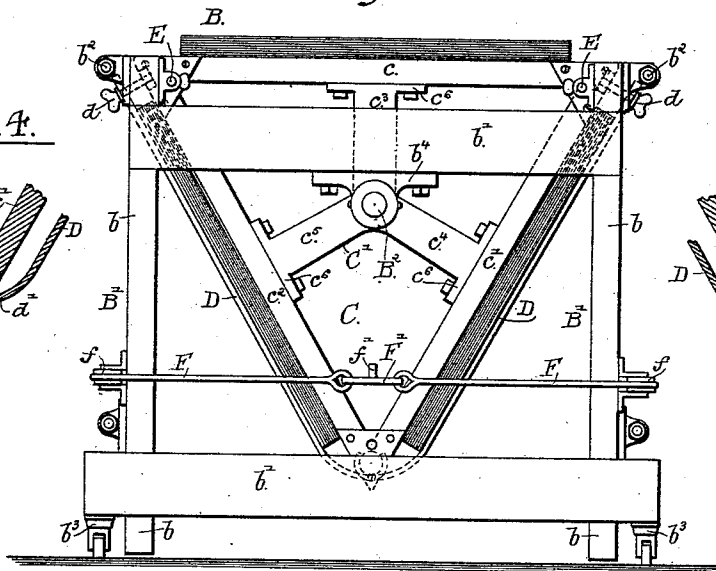

Fig. 4.

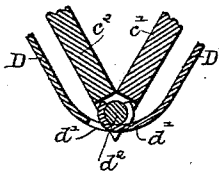
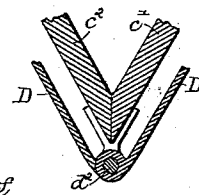

Fig. 5.



Witnesses

Wm. S. Hemming  
Louis H. Whitehead.

Inventor

Israel Reens

by Dayton, Cook & Brown

Attorneys.

I. REENS.  
TAILOR'S TABLE.

No. 420,212.

Patented Jan. 28, 1890.

Fig. 6.

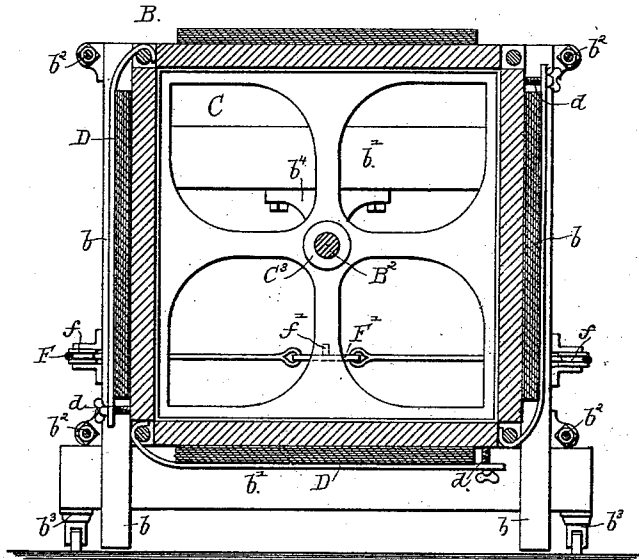
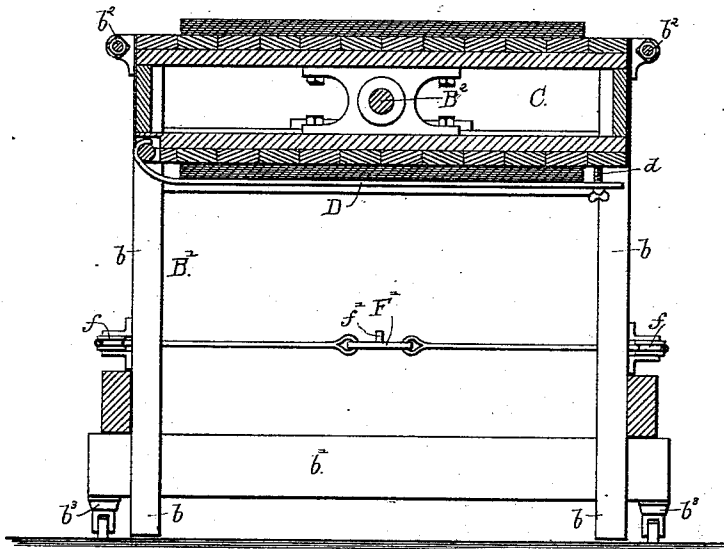

Fig. 7.



Witnesses  
*Wm. J. Hemming*  
*Louis W. Whitehead*

Inventor  
*Israel Reens*  
 by *Dayton, Pool & Brown*  
Attorneys.

# UNITED STATES PATENT OFFICE.

ISRAEL REENS, OF CHICAGO, ILLINOIS, ASSIGNOR OF ONE-HALF TO A. L. SINGER & CO., OF SAME PLACE.

## TAILOR'S TABLE.

SPECIFICATION forming part of Letters Patent No. 420,212, dated January 28, 1890.

Application filed August 24, 1889. Serial No. 321,875. (No model.)

### *To all whom it may concern:*

Be it known that I, ISRAEL REENS, of Chicago, in the county of Cook and State of Illinois, have invented certain new and useful  
5 Improvements in Marking and Cutting Tables for Cloth-Cutting Machines; and I do hereby declare that the following is a full, clear, and exact description thereof, reference being had  
10 to the accompanying drawings, and to the letters of reference marked thereon, which form a part of this specification.

This invention relates to a novel construction in a combined cloth marking and cutting  
15 table, and more particularly to that kind of table used for marking and cutting a plurality of pieces of cloth at a time, said pieces of cloth being arranged one upon the other and having the top piece suitably marked where  
20 it is intended to be cut.

The invention is adapted for use more particularly in factories and the like, where numbers of garments are made, which are known upon the market as "ready-made"  
25 garments. Heretofore in making this class of garments it has been customary to employ two large tables, the cloth being marked upon one and cut upon the other, said tables being commonly about twenty feet long and about  
30 five feet wide. A plurality of pieces of cloth, usually not less than eight in number, depending upon the weight of the goods, are arranged one upon the other and laid upon the marking-table. The top piece of cloth is then marked in a familiar manner. The  
35 pieces of cloth are then clamped together along the edges by suitable U-shaped clamps and thumb-screws, rolled up, and carried to the cutting-table by an attendant, where they are unrolled, spread out, and cut. There are  
40 many objectionable features to this method, one of which is the difficulty in preventing the disarrangement of the pieces of cloth when they are rolled up and unrolled, as described, it being found impracticable to employ such  
45 a number of clamps as would hold the pieces of cloth in the desired position. Moreover, the said rolls are not usually placed upon the cutting-table by the attendant, but are thrown upon the floor adjacent thereto, which also  
50 serves to disarrange them. It is obvious that when the cloth is unrolled it becomes neces-

sary to rearrange and smooth the same, which occupies considerable time.

In another application filed by me August 13, 1889, Serial No. 320,628, I have described a  
55 method of marking and cutting goods which entirely obviates the above-mentioned as well as other objections in systems heretofore employed. In said application I have described the use of a plurality of combined marking  
60 and cutting tables mounted upon rollers, whereon the cloth is first laid out and marked, the table then moved to the cutting implement, and the cutting-knife applied to the cloth without removing the latter from the  
65 table. I have found by experience that this method not only requires the use of a large number of marking and cutting tables, but also requires a large amount of floor-space, in order that goods may be laid out and marked  
70 upon one table while the person operating the cutting-machine is cutting the cloth upon another table. I find that by the system set forth in my said application one skilled machine-operator can cut cloth which requires  
75 eight or nine skilled markers to prepare and mark for him, thus requiring eight or nine tables to each cutting-machine in order to keep the latter constantly at work. In factories where hundreds of workmen are em-  
80 ployed it will be obvious that a very large amount of floor-space would thus be required, which, if located in a city, means a large rental. To overcome these objections I have made the present invention, which consists  
85 in providing a combined marking and cutting table with a plurality of sides and devices for securing the cloth thereto, the several sides of which are severally adapted to be brought on top for the purpose of mark-  
90 ing and cutting the cloth thereon.

The invention embraces the novel features of construction and combination of parts herein described, and more particularly pointed out in the appended claims.

In the accompanying drawings, Figure 1 is a plan view of a table constructed in accordance with my invention and arranged adjacent to the cutting devices. Fig. 2 is a view in side elevation of the table, with certain  
95 parts in vertical section. Fig. 3 is an end view of the same. Figs. 4 and 5 are detail

sectional views showing different ways of securing the cloth-clamping plate to the table. Fig. 6 is a vertical transverse view of a four-sided table. Fig. 7 is a similar view of a two-sided table.

In said drawings, A indicates a stationary horizontal frame or table, which is provided with suitable guides or ways  $a$ , upon which the cutting devices travel in a familiar manner. Said frame embraces a side piece  $A'$ , which is about the same length as that of the combined marking and cutting table herein-after described, and an end piece  $A^2$ , of about the same length as the end of said table.

$A^3$  is a traveling carriage carrying the pivoted arm  $a'$ , upon the end of which the cutting device proper is mounted.

$A^4$   $A^4$  are fast and loose pulleys mounted upon a shaft  $a^2$ , which latter is suitably journaled in the standards  $a^3$ . A driving-belt  $a^4$  passes over the fast pulley and communicates motion to the cutting-machine through the medium of an endless belt  $a^5$ , which passes over suitable pulleys  $a^6$  on the frame or table  $A$ , pulleys  $a^7$  on the carriage  $A^3$ , and pulley  $a^8$  on the end of the shaft  $a^2$ .

$A^5$  is the usual sliding bar, having two arms  $a^9$  embracing the belt  $a^4$ . Said bar  $A^5$  is pivotally connected to one end of the lever  $A^6$ , which is supported pivotally at  $a^{10}$  in any convenient manner.

I have shown several forms of supporting-table; but the construction which I prefer is the three-sided table illustrated in Figs. 1, 2, and 3. In said figures, B is the combined marking and cutting table referred to, comprising a supporting-frame  $B'$  and a revoluble table C, having a plurality of sides. The said supporting-frame  $B'$  consists of four uprights  $b$   $b$   $b$   $b$ , arranged one at each corner, connected at the ends by cross-pieces  $b'$   $b'$  and along their sides by brace-rods  $b^2$   $b^2$ . The lower one of said cross-pieces  $b'$  at each end extends somewhat beyond the uprights  $b$ , and such extended portions are each provided upon its ends with casters  $b^3$   $b^3$ , whereby the said supporting-frame is capable of being rolled from place to place. The upper cross-pieces  $b'$   $b'$  are each provided, preferably on their lower edges or faces, with the hangers  $b^4$ . The upper brace-rod  $b^2$  may be omitted, however.

The table proper is composed of three pieces  $c$ ,  $c'$ , and  $c^2$ , arranged and secured together so that an end view of the same, as seen in Fig. 3, will present an equilateral triangle. In practice said side pieces are secured together by means of brackets  $C'$ , located at each end thereof, and also at such suitable distances between the ends as will be found most convenient and practicable. Each of the said brackets  $C'$  comprises three arms  $c^3$   $c^4$   $c^5$ , arranged at equal angles to each other and provided at their outer ends with suitable plates  $c^6$ , by means of which said arms are secured to the side pieces of the table.

$C^3$   $C^3$  indicate journal-bearings formed in the brackets  $C'$  at the point of junction at the arms thereof.

$B^2$  indicates a horizontal shaft, which extends the whole length of the supporting-frame  $B'$  and is rigidly secured at its ends within the hangers  $b^4$   $b^4$ . The said shaft passes through the journal-bearings  $C^3$  of the brackets  $C'$ , thereby making said table revoluble.

D D indicate flat clamping-plates arranged upon the sides  $c'$  and  $c^2$  of the table. Said clamping-plates are arranged to extend entirely across the said side and to be secured in such position by means of set-screws  $d$   $d$  in a familiar manner. As shown in Figs. 3 and 4, said plates are provided with bended ends  $d'$ , which engage the rod  $d^2$ , located at the apex of the angle formed by two of the sides  $c'$   $c^2$ , a portion of the adjacent edges of the sides being cut away, as shown in Fig. 4, for the insertion of said rod  $d^2$ . In some cases I join the hooked or bended ends  $d'$  by an ordinary hinge-joint, as shown in Fig. 5. In some cases I may dispense with the rod  $d^2$ , in which event the adjacent edges of the sides  $c'$   $c^2$  do not touch each other, and the bended ends  $d'$  are hooked directly over the edge of said sides  $c'$   $c^2$ , as will be obvious without illustration.

E are ordinary barrel-bolts secured to the frame B and adapted to be moved so that the end  $e$  of the bolt will enter a suitable hole or opening  $e'$  in the end of one of the side pieces  $c$ ,  $c'$ , or  $c^2$ , as the case may be, and thus securely lock or fasten the table C to the frame B and prevent rotation of the table. It will be understood, of course, that any ordinary pin or plug passing through a hole or opening in the frame and into a hole or opening in the end of the table which registers with the hole in the frame will answer the same purpose—to wit, the locking of the revoluble table, and thus preventing its rotation on the shaft.

F is a cord or cable passed entirely around the table B and being supported upon suitable pulleys  $f$ , secured at convenient points on the frame  $B'$ . The ends of the cable F are secured to a plate  $F'$ , which latter is provided with an upright pin or projection  $f'$ , adapted to engage a suitable hole in the end of the pivoted lever  $A^6$ . It is obvious that by a movement of the lever  $A^6$  one way or the other the sliding bar  $A^5$  will be moved, and thereby the belt  $a^4$  will be shifted from the fast to the loose pulley, or the reverse. When, therefore, the table B has been moved into position adjacent to the cutting-machine, as illustrated in Fig. 1, the plate  $F'$  will be secured to the end of the lever  $A^6$ . The operator of the cutting implement will thus have complete control of the shifting device, and may start or stop the cutting-machine from any point at which he may happen to be by simply reaching down to the cable F and pulling the same in the desired direction.

This feature of my invention I regard as very important, inasmuch as the operator is obliged to stop and start the cutting-machine very frequently, and heretofore he has been obliged to walk to the shifting device and move the lever A<sup>6</sup> by hand, which consumed time. For example, suppose the operator to be at that end of a twenty-foot table farthest from the shifter. To stop the machine for a moment or two only, he must leave, walk twenty feet, move the shifter, walk back twenty feet, adjust the cloth or perform such work as necessary, walk back twenty feet to the shifter, start the machine, and then return to the cutting-machine and resume work. He has walked eighty feet, and he has left his cutting implement in the cloth while he has walked the half of this distance. Should the cloth have become folded or crumpled up and the operator desire to stop the machine suddenly, he could heretofore do so only by leaving the machine and walking to the shifter, as above explained, permitting the cutter in the meantime to continue to destroy the goods. In such cases it is very desirable that the operator be able to retain his hold on the cutting implement or on the goods with one hand while he stops the machine with the other. This he is enabled to do by my shifting attachment, at the same time saving valuable time.

I do not desire to limit my invention to a table having any particular number of sides, and I have therefore illustrated in Fig. 6 a table having four sides and in Fig. 7 one having two sides. While it will be understood that a greater number of sides may be employed in some instances, yet I find a three-sided table the most convenient for narrow goods and a wide two-sided table the preferable form for wide or six-quarter goods.

The parts of my invention being constructed and assembled as described, the operation is as follows: In using the devices herein described the workman or attendant whose duty it is to mark the cloth first turns the table C upon its axis until either the side c' or c<sup>2</sup> is uppermost. For example, I assume that the side c' is uppermost. After throwing back the clamp-plates D D the cloth is laid upon said side, arranged, and marked, the clamping-plates then placed across the same, and the end slacked by means of the set-screws d, thus securely fastening the cloth to the table, as before explained. The table C is then turned upon its axis until the side c<sup>2</sup> is uppermost, whereupon other pieces of cloth are laid thereon, marked, and clamped in the same manner. The table C is again turned on its axis until the side c is uppermost. The said side c, as has been noted, is not provided

with clamping-plates, so that after arranging and marking the cloth which is laid thereon the table is not turned again, but is kept in this last position, with the side c horizontal and uppermost. The entire table is then moved on its casters b<sup>3</sup> across the floor until it is in position within the frame A. The plate F' is then secured to the end of the lever A<sup>6</sup>.

The workman whose duty it is to cut the cloth performs that duty upon the cloth which is on the side c, and after cutting the said cloth is removed. The bolts E E are then withdrawn from the holes e' in the side piece c, and the table is turned on the shaft B<sup>2</sup>, and thus brings another of the sides of the table into position. When either of said side pieces c' c<sup>2</sup> is brought into a horizontal plane, the bolts E are again engaged with the holes e' thereon and the clamping-plates D D removed, the cloth cut and removed and the table again operated to bring the other of said sides into position. After the cloth thereon has been cut and removed the entire table is thereupon rolled away from the frame A to make place for another table.

I claim as my invention—

1. A table of the class specified, comprising a movable supporting-frame, a table revolvably supported upon said frame and having a plurality of sides or faces, and one or more clamps adapted to be applied to said sides or faces, substantially as specified.

2. The combination of a movable supporting-frame, a table revolvably supported thereon, provided with one or more sides or faces, and a bolt or bolts on said frame and adapted to engage the ends of said table and lock the same against revolution on its axis, with a plurality of clamps adapted to engage the face or faces of said table, substantially as specified.

3. A movable supporting-frame, a marking and cutting table revolvably supported thereon, provided with one or more sides or faces, clamps for securing cloth to said side or sides, and an endless cable secured to and passing around said movable frame and adapted to be connected to the shifting device of a machine, in combination with a cutting implement adapted to operate upon said table and a belt-shifting device whereby by a pull on said cable in either direction said shifter is operated and power applied to or shut off from said cutting implement.

In testimony that I claim the foregoing as my invention I affix my signature in presence of two witnesses.

ISRAEL REENS.

Witnesses:

TAYLOR E. BROWN,  
GEORGE W. HIGGINS, Jr.