

W. S. Smith.

Dredger.

No. 63,661.

Patented Apr. 9, 1867.

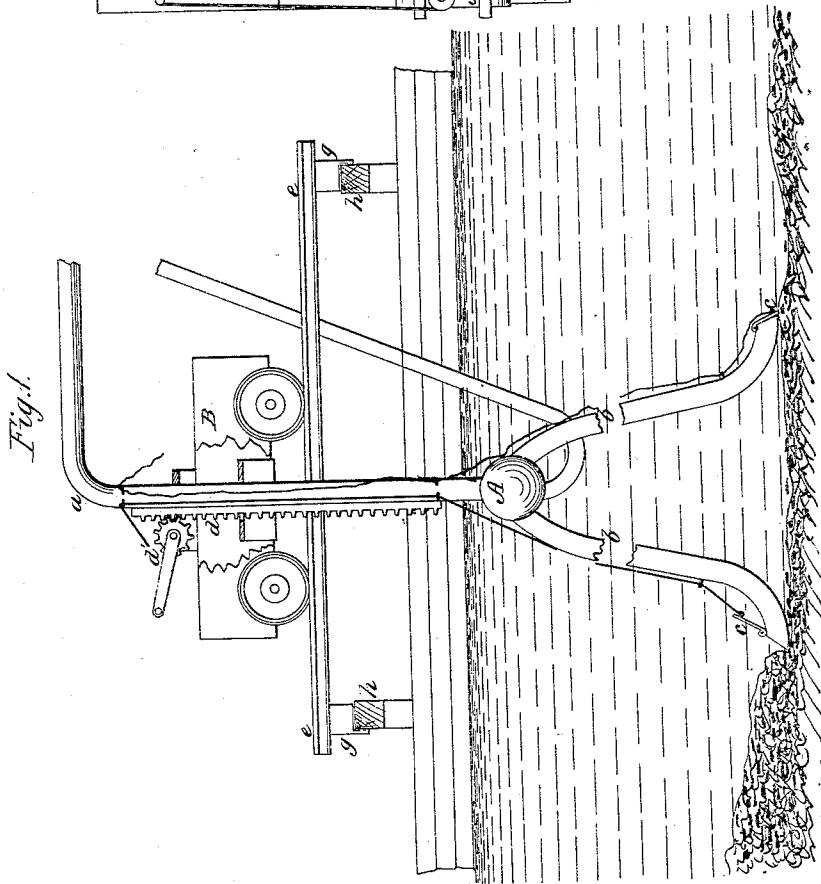
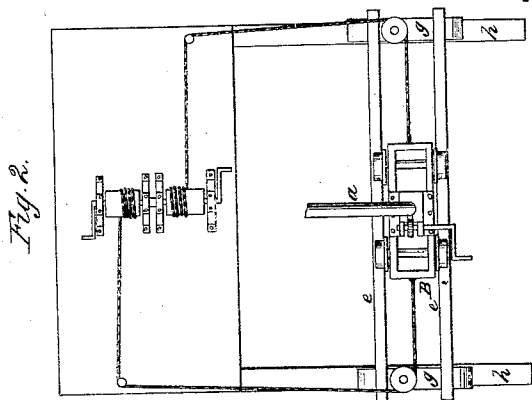

Witnesses:
Chas. Swacke
Wm. Trevin.

Inventor:
W. S. Smith
Per Munn & Co. attys

United States Patent Office.

WILLIAM SOOY SMITH, OF OAK PARK, ILLINOIS.

Letters Patent No. 63,661, dated April 9, 1867.

IMPROVEMENT IN EXCAVATING AND DREDGING.

The Schedule referred to in these Letters Patent and making part of the same.

TO ALL WHOM IT MAY CONCERN:

Be it known that I, WILLIAM SOOY SMITH, of Oak Park, in the county of Cook, and State of Illinois, have invented a new and improved Mode of Excavating Under Water for Dredging Docks, Ship Channels, and Canals, and Sinking Hollow Piles, Cylinders, or Caissons, by the direct application of steam; and I do hereby declare that the following is a full, clear, and exact description thereof, which will enable others skilled in the art to make and use the same, reference being had to the accompanying drawings, forming part of this specification, in which—

Figure 1 is a side elevation of an apparatus illustrating the mode of applying steam according to my improved mode of dredging and excavating under water.

Figure 2 is a plan of the same.

Similar letters of reference indicate like parts.

This invention relates to an improvement in the method of excavating solid and semi-fluid earthy substances for the purpose of dredging the bottoms of rivers, channels, canals, docks, wharf-slips, and other similar depositories of silt, and of removing the earth to sink hollow piles, cylinders, caissons, coffer-dams, and other similar works wherein water shall be naturally or artificially supplied for covering the bottom, in order that the operation of excavating the earthy substances may be performed under water. My improved mode of accomplishing these objects consists in the direct application of steam to the work of excavation and dredging by means of the so-called steam siphon, arranged and operated as herein described and shown in the drawings, or by any equivalent devices.

To apply the steam siphon for these purposes, as I propose, I suspend it to a movable truck or carriage, which may be shifted over the area of operations rapidly and conveniently, and in such manner as to permit the pipe to descend as the work of dredging or excavating proceeds, and be moved about freely in any required position. The arrangement and devices for effecting these objects may be modified to adapt them to the nature and conditions of the work to be performed without changing the essential features or affecting the principle of my improved mode of excavating and removing solid and semi-fluid earthy materials from under a body of water through the direct agency of steam, in the manner hereinafter shown and described.

A is the receiving chamber of an ordinary steam siphon, having a steam supply pipe leading into it, shown in red. *a* is the ejection pipe for discharging the materials excavated, with which may be coupled a flexible and incompressible pipe leading wherever it may be necessary to make the deposit. There may be one or more suction or excavating pipes, *b*, formed at the lower end with a turn or goose neck, having a scoop or scraper-shaped end, and provided with a collar for turning freely in any direction, for the purpose of operating advantageously on all sides, as hereinafter described. The ends or mouths of the suction pipes *b*, when two are employed, are provided with flap-valves or hinged caps, *c c*, to be closed and opened alternately, as desired, by means of connecting wires or ropes, for using either one or the other of them only at a time. The steam siphon will require to be lowered and raised as the work of excavation proceeds, and for this purpose I connect with it a rack, *d*, and pinion, *d'*, by which this movement may be performed. In some cases, also, it may be necessary to provide for a change in the position of the steam siphon to give movement in different directions laterally over a considerable area in order to operate rapidly and conveniently in the work of dredging or excavating. For effecting these objects I propose to employ a car-truck, B, placed upon a movable pair of rails, *e e*, which are supported by sliding frames, *g g*, that rest upon sills or beams, *h h*, projecting or extending over the place of operation. The truck B may be moved in one direction by shifting the position of the rails *e e* upon the timbers *g g*, as necessary, and in other and opposite directions by means of tackle connected with the truck and passing over sheaves or snatch-blocks to a double drum or windlass for rapidly drawing the carriage on the rails either way when required, as shown in red, fig. 2. Steam or other power may be employed for this service.

Having made these or other equivalent arrangements for dredging or excavating by my improved method, it will be observed that when the lower ends or mouths of the suction pipes of the steam siphon are placed and kept in actual contact with the mud, gravel, clay, and other earthy substances, at the bottom of docks, slips, canals, navigation channels, or other places which require dredging under water, a strong jet or column of steam is then admitted into the siphon chamber A, directed into the ejection pipe *a*, in the usual way for raising water,

thus producing a powerful suction force in the excavating pipe *b*, which will draw up the earthy materials under the water, and carry them off in a steady, continuous column, through the discharge pipe to the dumping-scow or other place of deposit. By this mode of excavating and removing the accumulations of silt under water the work of dredging may be performed with far greater rapidity and economy than by the ordinary method of operating with scoops or dredging machines.

To sink hollow piles, caissons, and other similar operations, in places not naturally covered with water, a body of water must be introduced to cover the bottom of the works, and a constant supply maintained during the process of excavation. Works of this class are often attended with damaging delays by reason of the difficult and slow progress made in excavating, and especially in connection with military operations, when the sinking of hollow piles and coffer-dams for foundations requires dispatch. By my mode of excavating under water herein described such works may be executed with facility and dispatch unexampled in any other mode of operation.

Having described my invention, I claim as new, and desire to secure by Letters Patent—

The combination and arrangement of the receiving chamber *A*, tubes *b b*, ejection pipe *a*, caps *c c*, rack *d*, pinion *d'*, car-truck *B*, movable rail *e e*, upon the sliding frames *g g* of the sills *h h*, substantially as herein set forth for the purpose specified.

The above specification of my invention signed by me this 11th day of December, 1866.

WILLIAM SOOY SMITH.

Witnesses:

WM. F. McNAMARA,

ALEX. F. ROBERTS.