

June 4, 1929.

G. E. ROGERS

1,715,513

FUSE FOR PROJECTILES

Filed July 12, 1928

Fig. 1.

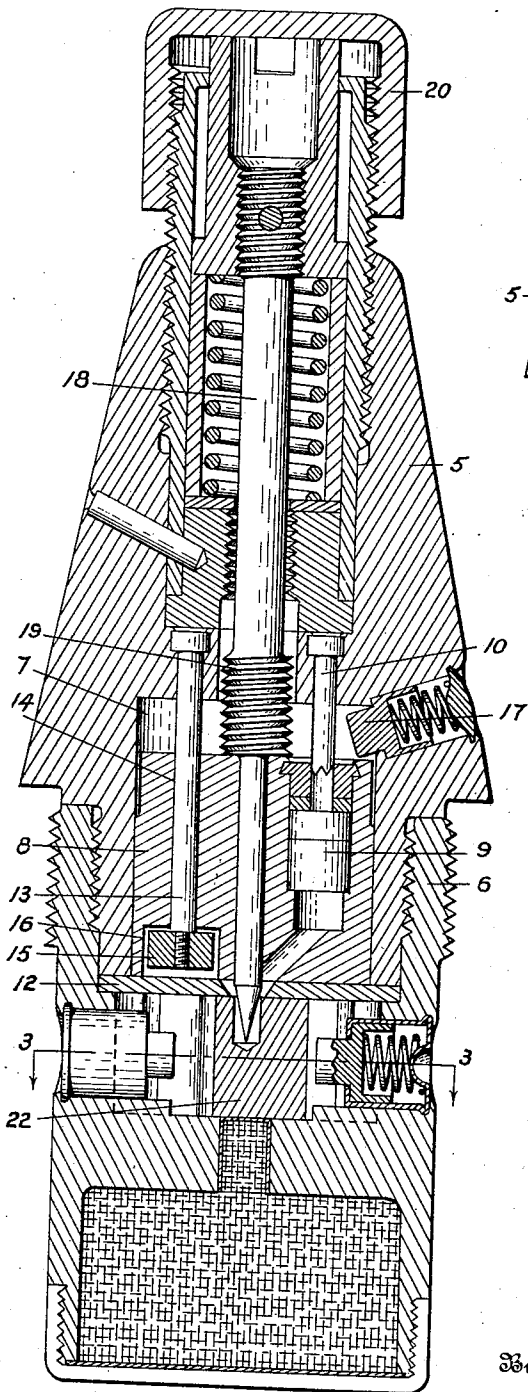

Fig. 2.

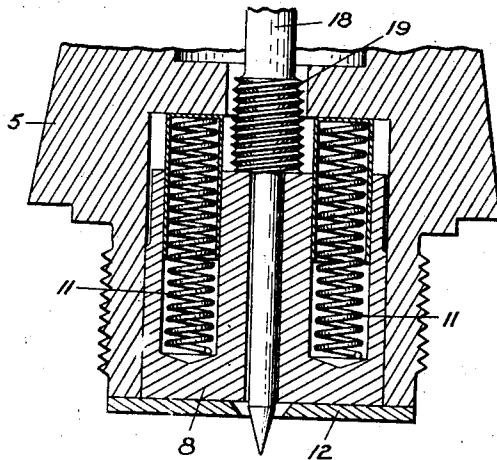
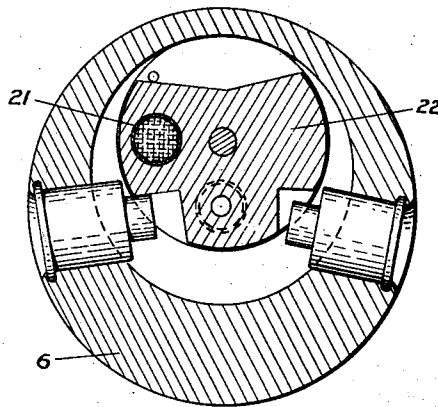

Fig. 3.



Inventor
Gilbert E. Rogers

By *W. N. Roach*

Attorney

Patented June 4, 1929.

1,715,513

UNITED STATES PATENT OFFICE.

GILBERT E. ROGERS, OF ROCKAWAY, NEW JERSEY.

FUSE FOR PROJECTILES.

Application filed July 12, 1928. Serial No. 292,155.

(GRANTED UNDER THE ACT OF MARCH 3, 1883, AS AMENDED APRIL 30, 1928; 370 O. G. 757.)

The subject of this invention is a fuse for projectiles.

The principal object of the invention is to provide a coupling for holding a spring actuated plunger in position for assembly of the fuse which coupling will also serve to restrain the plunger against rotary movement during functioning of the fuse.

With the foregoing and other objects in view, my invention resides in the novel arrangement and combination of parts and in the details of construction hereinafter described and claimed, it being understood that changes in the precise embodiment of the invention herein disclosed may be made within the scope of what is claimed without departing from the spirit of the invention.

A practical embodiment of the invention is illustrated in the accompanying drawings, wherein:

Fig. 1 is a longitudinal sectional view of a fuse constructed in accordance with the invention;

Fig. 2 is a fragmentary sectional view through the plunger taken at right angles to Fig. 1;

Fig. 3 is a sectional view on the line 3—3 of Fig. 1.

Referring to the drawings by numerals of reference:

The invention is illustrated in connection with a combination instantaneous and delay action fuse of a type disclosed in Patent No. 1,648,603. This fuse consists of a head 5 which is assembled to a fuse body 6 preferably by threaded engagement. The head 5 is formed with a cavity 7 in its rear portion in which is to be placed a plunger 8 carrying an eccentrically disposed primer 9 which is to be set off by a stationary firing pin 10 fixed to the fuse head at the base of the cavity.

The plunger is normally maintained in the unarmed position by means of a pair of springs 11 which are seated against the floor of the cavity. When the fuse body 6 is attached to the fuse head a disk 12 interposed between the two members forms a support to restrain movement of the plunger under the action of its springs 11. Prior to assembling the fuse head and body the plunger is held against the action of the

springs by means of a bolt 13 which is securable in the fuse head and after passing through a passage 14 in the plunger receives a nut 15. The outer face of the plunger may be recessed as at 16 to receive the nut. The bolt 13 by being positioned eccentrically of the plunger insures alinement of the primer 9 and firing pin 10 when inserting the plunger and prevents rotary movement of the plunger as it moves forward on impact.

Movement of the plunger to the armed position during assembly of the fuse is prevented by a centrifugally releasable locking pin 17 and also by an impact striker 18 which is axially of the fuse and is provided with an enlarged portion 19 which limits movement of the plunger in the direction of arming when the striker is held by means of a removable cap 20. The striker is adapted to function a detonator 21 carried in a rotor 22 mounted in the fuse body 6.

I claim:

1. A fuse including a head, a body secured thereto, a plunger, an element of a firing mechanism carried centrifugally by the plunger, a spring for maintaining the plunger in unarmed position, a bolt securable to the head and passing eccentrically through the plunger and a nut on the end of the bolt for opposing the action of the plunger spring.

2. In a fuse, a housing, a resiliently restrained plunger in the housing, and means passing eccentrically through the plunger and secured to the housing for holding the plunger in position of assembly.

3. In a fuse housing, a resiliently restrained plunger in the housing and means passing through the plunger and secured in the housing for holding the plunger in position of assembly.

4. A fuse housing, a plunger within the housing, and means passing through the plunger and engaging the housing to hold the plunger assembled and guide the plunger in its reciprocatory movement.

5. A fuse housing, a plunger within the housing, and means passing through the plunger and engaging the housing to hold the plunger assembled.

GILBERT E. ROGERS.