

April 4, 1967

H. STADLER ETAL

3,312,168

IGNITION DEVICE

Filed Sept. 8, 1964

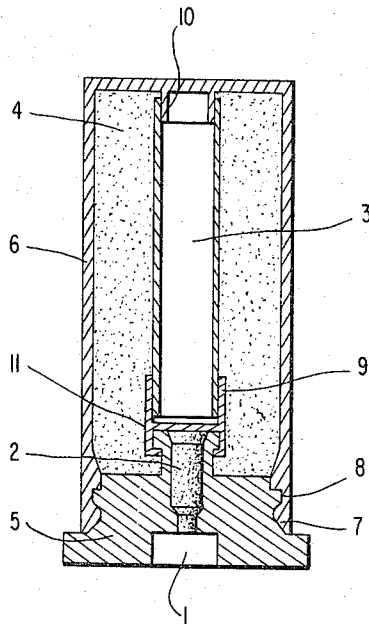

INVENTORS
HANS STADLER
HEINZ GAWLICK
BY
Dicke & Craig
ATTORNEYS

1

3,312,168

IGNITION DEVICE

Hans Stadler, Nurnberg, and Heinz Gawlick, Furth, Bavaria, Germany, assignors to Dynamit Nobel Aktiengesellschaft, Troisdorf, Germany

Filed Sept. 8, 1964, Ser. No. 395,616

Claims priority, application Germany, Sept. 7, 1963,

D 42,426

4 Claims. (Cl. 102—86.5)

The present invention relates to an ignition device, and more particularly to a surface igniter for incendiary compositions.

Certain types of apparatus exist in which an incendiary composition has to be ignited and more particularly in such a manner that the combustion or burning process sets in along the entire axial extent of the incendiary composition. For that purpose the incendiary composition is provided with a recess, into which a so-called "surface-igniter" is inserted which is called "surface-igniter" because it to ignite not only within a narrow limited zone but over the entire surface thereof. The surface-igniters used heretofore consist in general of black powder and were therefore sensitive against external influences and resulted in relatively long ignition periods.

The surface-igniter according to the present invention assures a completely satisfactory surface ignition by the following constructions:

A rapidly ignitable pyrotechnical mixture is assembled into a cartridge about a readily destructible hollow cylinder. A primer is installed at the cartridge bottom whose ignition flash or jet pierces and crushes the hollow cylinder. The latter is destroyed thereby so that the ignition flash or jet ignites the pyrotechnical mixture along the entire axial extent thereof. By reason of the very small ignition time that amounts only to 1 millisecond or less, the incendiary composition is now ignited immediately over the entire axial extent thereof. In order to produce within the hollow cylinder an ignition flash or jet which is as powerful as possible, it is appropriate to provide a supplementary charge to the rear of the primer, which produces the ignition flame or jet, properly speaking. During burning of the pyrotechnical mixture the cartridge case which consists of a readily destructible material is immediately eliminated so that the ignition flame can reach without obstruction the incendiary composition.

Paper and plastic material of any appropriate known type are thereby of particular consideration as materials for the hollow cylinder.

The pyrotechnical mixture is made appropriately of about 75 parts of barium nitrate and of about 25 parts of magnesium powder or a powder of an aluminum-magnesium alloy.

Accordingly, it is an object of the present invention to provide a surface-igniter of the type described above which obviates the drawbacks encountered with the prior art constructions.

It is another object of the present invention to provide a large surface-ignition device that is essentially insensitive against external influences and results in an ignition time that is extraordinarily short.

Another object of the present invention resides in the provision of surface-igniters for incendiary compositions or powder trains that assure completely satisfactory ignition as well as reliable operation at all times.

Still a further object of the present invention resides in the provision of a surface-igniter that is capable of producing a powerful ignition flame without the detriments normally encountered therewith in the prior art.

These and other objects, features and advantages of the present invention will become more obvious from the

2

following description when taken in connection with the accompanying drawing which shows in the single figure thereof, for purposes of illustration only, one embodiment in accordance with the present invention.

Referring now to the single figure of the drawing which is an axial longitudinal cross section of one embodiment of a surface ignition device of the present invention, the surface igniter illustrated therein has the shape of a cartridge and includes the bottom piece 5 made of metal and the case 6 consisting, for example, of plastic material and closed at the top thereof. The lower zone 7 of the case 6 is reinforced and provided with a recess into which, upon emplacement of the case 6 over the neck portion of the bottom piece 5, snaps an annular collar 8. A cup 9 is secured at the bottom piece 5 and a cup 10 is worked into the top of the case 6. A hollow cylinder 3 made of a readily destructible material is inserted between the two cups 9 and 10. The pyrotechnical mixture is designated in the drawing by reference numeral 4. As shown in the drawing, the pyrotechnical mixture 4 surrounds the hollow cylinder 3. Reference numeral 1 designates in the drawing a primer of conventional construction while reference numeral 2 designates a booster charge also of any conventional composition.

Operation

The operation of the surface-igniter according to the present invention is as follows:

During use of the surface-igniter according to the present invention, the primer 1 is ignited by any suitable known means which, in turn, ignites the booster charge 2. The separating or partition wall 11 formed by cup 9 and made of suitable material is thereby destroyed and the ignition jet or flash enters into the hollow cylinder 3. Since the hollow cylinder 3 is, according to postulation, readily destructible, it is removed and eliminated by the gas pressure and/or the flame influence, and the ignition flash or jet can now ignite the pyrotechnical mixture 4 instantaneously over its entire length. The case 6 is then destroyed also and the ignition flame is brought into contact over the entire length of the ignition charge 4 with the incendiary composition.

While we have shown and described one embodiment in accordance with the present invention, it is understood that the same is not limited thereto but is susceptible of numerous changes and modifications as known to a person skilled in the art, and we therefore do not wish to be limited to the details shown and described herein but intend to cover all such changes and modifications as are encompassed by the scope of the appended claims.

We claim:

1. A surface igniter provided with ignition means for igniting incendiary compositions, comprising a cartridge case having a tubular case shaft closed at its forward end and a bottom piece closing the rearward end of said tubular case shaft; a readily destructible axially extending hollow tubular body means within said cartridge case operable to form a substantially annular sealed chamber between said cartridge case and said body means; an axially extending firing channel formed by and within said body means consisting solely of gases, and extending for substantially the entire length of said tubular case shaft; a rapidly ignitable pyrotechnical mixture within said cartridge case substantially filling said substantially annular sealed chamber; ignition means located adjacent the rear of said body means for producing an ignition flash that will first enter and fill said firing channel, and then pierce and destroy said body means to ignite said pyrotechnical mixture substantially simultaneously over the entire internal surface adjacent said body means; said hollow tubular body means including a tubular member and a

3

separate cup-shaped member telescopically connected with the rearward portion of said tubular member; said bottom piece having a forwardly extending projection; said cup-shaped member being telescopically connected with the forward portion of said projection; and said case shaft consisting of a readily destructible material.

2. A surface igniter according to claim 1, wherein said case shaft includes a depending cup-shaped element at its forward closed end telescopically connected with the forward end of said tubular member.

3. A surface igniter provided with ignition means for igniting incendiary compositions, comprising a cartridge case having a tubular case shaft closed at its forward end and a bottom piece closing the rearward end of said tubular case shaft; a readily destructible axially extending hollow tubular body means within said cartridge case operable to form a substantially annular sealed chamber between said cartridge case and said body means; an axially extending firing channel formed by and within said body means consisting solely of gases, and extending for substantially the entire length of said tubular case shaft; a rapidly ignitable pyrotechnical mixture within said cartridge case substantially filling said substantially annular sealed chamber; ignition means located adjacent the rear of said body means for producing an ignition flash that will first enter and fill said firing channel, and then pierce and destroy said body means to ignite said pyrotechnical mixture substantially simultaneously over the entire internal surface adjacent said body means; said hollow tubular body means including a tubular member; and a separate cup-shaped member telescopically connected with the rearward portion of said tubular member and operatively connected to said bottom piece; said cup-shaped member including a transversely extending partition wall means operable to close the rearward end of said tubular member; said case shaft including a dependent cup-shaped element at its forward closed end telescopically connected to the forward end of said tubular member; and said case shaft consisting of a readily destructible material.

4. A surface igniter provided with ignition means for igniting incendiary compositions, comprising a cartridge case having a tubular case shaft closed at its forward end and a bottom piece closing the rearward end of said tubular case shaft; a readily destructible axially extending hollow tubular body means within said cartridge case operable to form a substantially annular sealed chamber between said cartridge case and said body means; an axially extending firing channel formed by and within

4

said body means consisting solely of gases, and extending for substantially the entire length of said tubular case shaft; a rapidly ignitable pyrotechnical mixture within said cartridge case substantially filling said substantially annular sealed chamber; ignition means located adjacent the rear of said body means for producing an ignition flash that will first enter and fill said firing channel, and then pierce and destroy said body means to ignite said pyrotechnical mixture substantially simultaneously over the entire internal surface adjacent said body means; said hollow tubular body means including a tubular member and a separate cup-shaped member telescopically connected with the rearward portion of said tubular member; said bottom piece having a forwardly extending projection; said cup-shaped member being telescopically connected with the forward portion of said projection; said cup-shaped member including a transversely extending partition wall means operable to close the rearward end of said tubular member and provide said cup-shaped member with substantially H-shaped cross-section; said bottom piece projection having an enlarged annular forward end; said cup-shaped member having a rearward extending tubular portion engaging said projection annular enlargement and provided with an inwardly extending annular flange at its rearward end engaging the rearward portion of said projection annular enlargement; said ignition means including primer means and booster charge means partially located within said projection; said case shaft, including its forward end closure, being homogeneously integrally made of plastic and including a depending homogeneously integrally plastic cup-shaped element at its forward closed end telescopically connected with the forward end of said tubular body means; and said case shaft consisting of a readily destructible material.

References Cited by the Examiner

UNITED STATES PATENTS

| | | | |
|-----------|---------|-------------|----------|
| 664,116 | 12/1900 | Barrallon | 102—40 |
| 2,955,535 | 10/1960 | Show et al. | 102—70 X |
| 2,959,001 | 11/1960 | Porter | 60—35.6 |

FOREIGN PATENTS

| | | |
|---------|---------|----------------|
| 215,863 | 6/1961 | Austria. |
| 1,706 | 12/1893 | Great Britain. |

BENJAMIN A. BORCHELT, *Primary Examiner*.
G. H. GLANZMAN, *Assistant Examiner*.