

Oct. 12, 1965

K. I. CHRISTENSSON

3,211,028

IMPACT WRENCH

Filed Nov. 15, 1963

2 Sheets-Sheet 1

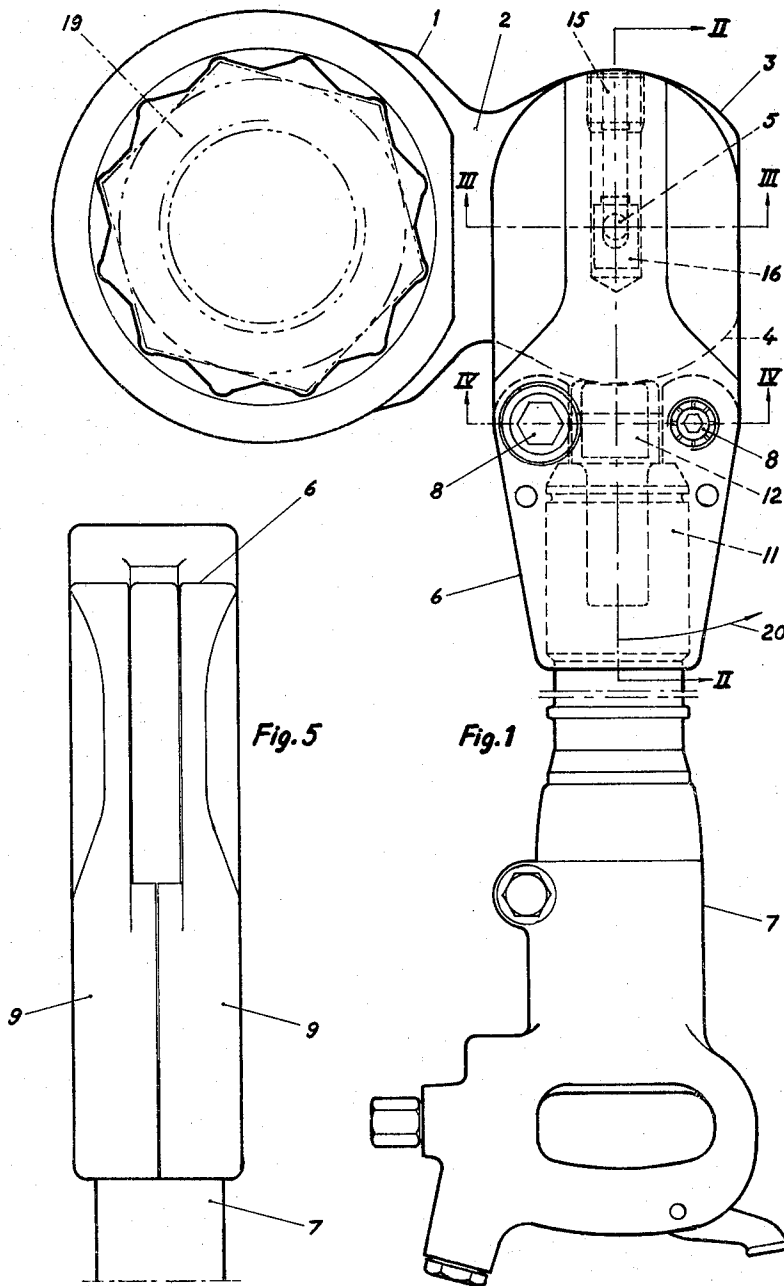

Oct. 12, 1965

K. I. CHRISTENSSON

3,211,028

IMPACT WRENCH

Filed Nov. 15, 1963

2 Sheets-Sheet 2

Fig. 2

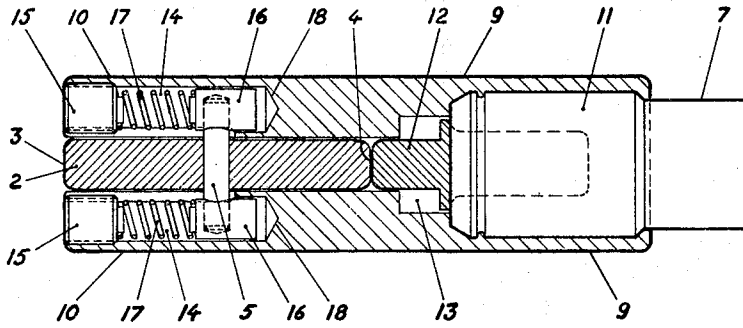

Fig. 3

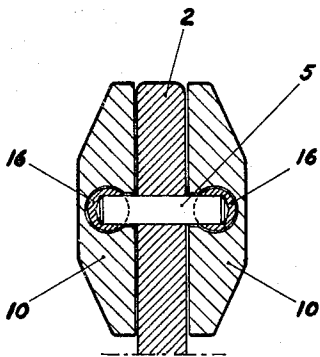
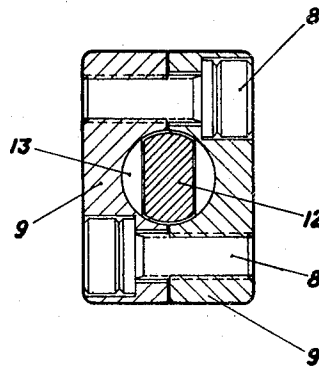

Fig. 4



1

3,211,028

IMPACT WRENCH

Kjell Ivar Christensson, Kollegiegatan 3A,

Malmö, Sweden

Filed Nov. 15, 1963, Ser. No. 324,109

Claims priority, application Sweden, Nov. 23, 1962,

12,584/62

2 Claims. (Cl. 81—52.3)

Especially in ships where the spaces are very restricted it is often very difficult to tighten and untighten the nuts on machines and machine details. These nuts may many a time have considerable dimensions and it happens that one is forced to use a sledge hammer to beat the handle of a key on the nut for obtaining an acceptable tightening. However, the tightening will then often be too hard which results in the occurring of fissures on the machine, e.g. on the cylinder head of the same. Proposals have been made to tighten and untighten nuts by intermediary of a pneumatically driven rivet hammer the beating means of which attacks the outer end of the key handle.

This invention is based on the last mentioned idea and has reference to such an implement comprising a key fitting to the nut or the like and a pneumatic hammer for turning said key. The main feature of the invention is to be seen therein that a retainer is journalled about a shaft extending through an arm on said key, the head of said pneumatic hammer being attached to said hammer in such a way that during operation of the same its beater will beat against one border of said arm, said border being shaped substantially as the arc of a circle. Due to this arrangement the key and the hammer, the latter may comprise a common rivet hammer, form a unit and after the tightening of a nut it is only necessary to swing the hammer about said shaft half a revolution for the untightening of the nut. The key arm may during the tightening of the nut turn relatively to the retainer with the hammer. The tightening can hereby be carried out in spaces hard to reach. The longitudinal direction of the hammer may be adjusted to enclose acute or obtuse angles with the longitudinal direction of the key arm. The degree of tightening may always be easily controlled.

According to a preferred embodiment the retainer at which the pneumatic hammer is attached, is bifurcated and extends with its two branches on both sides of the key arm. The implement is hereby rendered very strong and it can withstand considerable stresses.

According to another embodiment, the retainer branches are provided with each their axial bore with a piston movable therein in the longitudinal direction of said bore against the action of a spring. The shaft extending through said key arm is carried at its two ends by the two pistons. Due to this buffering device the implement will operate very smoothly at the beginning of the tightening of the nut when there does not occur any notable resistance, as well as at the end of the tightening when the resistance is very high.

When according to another preferred embodiment of the implement according to the invention the two ramming borders of the key arm extend substantially along the same arc of a circle with its centre situated in the centre of the pivot shaft, the beater of the implement may, when it has acted on one of the beat borders, be brought to act on the other border when the retainer with the hammer has been swung half a revolution relative to the key arm for turning the nut in the opposite direction.

An example of a device in accordance with the invention will now be described with reference to the accompanying, partly diagrammatic drawings, in which:

FIG. 1 is a plan view of an implement according to the invention,

2

FIG. 2 shows a longitudinal section through the retainer of the implement on the line II—II in FIG. 1,

FIG. 3 shows a cross section on the line III—III in FIG. 1,

FIG. 4 shows a cross section on the line IV—IV in FIG. 1, and

FIG. 5 is a side elevation of the retainer.

The key 1 shown in FIG. 1 comprises a so-called ring beater key from which an arm 2 extends radially. The arm 2 is provided with essentially arc-shaped beat borders 3 and 4 with the centre situated in the centre portion of said arm 2. This centre portion is passed through by a shaft 5 on which there is journalled a retainer 6 for a pneumatic rivet hammer 7. The retainer 6 comprises two plates 9 kept against each other by means of expansion bolts 8. The retainer 6 extends at one end with two branches on either side of the key arm 2. At the opposite side the plates 9 embrace the head 11 on the rivet hammer 7 so that this is steadily kept on the retainer 6. The rammer means 12 of the hammer 7 is axially movable in a longitudinal notch 13 in the retainer 6 and abuts against one of the beat borders 3 and 4 on the key arm 2 depending upon the position the hammer 7 takes relative to the key 1. The shaft 5 engages with its two ends longitudinal bores 14 in the branches 10 said bores at the outer ends closed by means of screw plugs 15. Due to this arrangement the key 1 with the arm 2 may, when the beater 12, in the position of the hammer 7 shown in FIG. 1, hits the beat border 4 of the arm, be turned in counter-clockwise direction according to FIG. 1 simultaneously as the shaft 5 is moved in the bores 14 in the direction towards the plugs 15.

So as to prevent at this movement that the shaft abuts against the plugs 15, the ends of the shaft 5 have been entered from the side into pistons 16 which are axially movable in each their bore 14 and between the plugs 15 and the adjacent end of the respective piston 16 springs 17 have been inserted in the bores 14, said springs 17 serving as buffers. The springs 17 prevent the pistons 16 from beating against the plugs 15 when the beater 12 has acted upon the key arm 2. An air cushion is formed between the bottom 18 in the bore 14 and the adjacent end of the respective piston 16 at this displacement and also this air cushion acts as a buffer at the displacement of the shaft 5 and thus also of the key arm 2 in the opposite direction or at the displacement of the retainer 6 in the beating direction.

When the nut 19 is to be tightened—it is assumed that the nut 19 has right-handed threads—the hammer 7 with the retainer 6 is swung half a revolution in counter-clockwise direction as indicated by the arrow 20 so that the beater 12 thereupon will work against the beater border 3 on the key arm 2.

The present invention has been described in detail above for purposes of illustration only and is not intended to be limited by this description or otherwise except as defined in the appended claims. Thus, the riveting hammer 7, the retainer 6 and the key 1 may be modified in many ways without departure from the scope of the invention. The retainer 6 may comprise one single bifurcated piece.

What I claim is:

1. An implement for tightening and loosening nuts and the like, comprising a key adapted to fit the nut or the like to be tightened or loosened, an arm projecting laterally from said key, a pivot shaft carried by said arm perpendicular thereto and offset from said key, said arm having two opposite convex arcuate borders approximately concentric with said pivot shaft, a retainer pivotally connected to said arm by said pivot shaft and swingable about said pivot shaft relative to said arm, a pneumatic hammer secured to said retainer and having

3

a reciprocable rammer, said retainer being swingable about said pivot shaft between a first position in which said rammer is engageable with one of said convex arcuate borders to tighten said nut or the like and a second position in which said rammer is engageable with the other of said convex arcuate borders to loosen said nut or the like.

2. An implement for tightening nuts and the like, comprising a key adapted to fit the nut or the like to be tightened, an arm projecting laterally from said key, a pivot shaft carried by said arm perpendicular thereto and offset from said key, said arm having a convex arcuate border approximately concentric with said pivot shaft, a retainer pivotally connected to said arm by said pivot shaft and swingable about said pivot shaft relative to said arm, said retainer being bifurcated with portions embracing opposite sides of said arm and said pivot shaft extending through said arm and into said opposite portions of said bifurcated retainer, a pneumatic hammer secured to said retainer and having a rammer engageable with said convex arcuate border of said arm in a direction approximately perpendicular to said line, each of said

4

opposite portions of said retainer being provided with a cylindrical recess extending parallel to the direction of movement of said hammer rammer and with a piston and buffer spring in each said recess, and opposite ends of said pivot shaft extending into transverse bores in said pistons, said buffer springs opposing movement of said arm, pivot shaft and pistons relative to said retainer by said hammer.

References Cited by the Examiner

UNITED STATES PATENTS

D. 105,338	7/37	McNaught.	
2,112,693	3/38	Douglass	81—52.3
2,119,968	6/38	Shaff	81—52.3 X

FOREIGN PATENTS

450,778 7/36 Great Britain.

WILLIAM FELDMAN, Primary Examiner.

MILTON S. MEHR, Examiner.