



US00D504147S

(12) **United States Design Patent**
Slinckx

(10) **Patent No.:** **US D504,147 S**

(45) **Date of Patent:** **** Apr. 19, 2005**

(54) **PAYMENT TERMINAL**

(75) Inventor: **René Slinckx**, Wezembeek-Oppem (BE)

(73) Assignee: **Banksys S.A.**, Brussels (BE)

(**) Term: **14 Years**

(21) Appl. No.: **29/187,898**

(22) Filed: **Aug. 8, 2003**

(30) **Foreign Application Priority Data**

Feb. 25, 2003 (WO) DM/062 930

(51) **LOC (7) Cl.** **18-01**

(52) **U.S. Cl.** **D18/4.6**

(58) **Field of Search** D18/1, 2, 4.1-4.6,
D18/5-7, 10, 11; D14/338, 339, 341, 346,
387; 235/419-434, 61 R-60.22, 2, 7 R-16,
379-382; 705/15-17; 364/706-710

(56) **References Cited**

U.S. PATENT DOCUMENTS

D310,094 S * 8/1990 Noguchi D18/7

D317,755 S * 6/1991 Lerude et al. D14/346
D340,919 S * 11/1993 Lee D18/4.6
D364,386 S * 11/1995 Bramlett et al. D14/387
D381,675 S * 7/1997 Droege et al. D18/4.6

* cited by examiner

Primary Examiner—Caron D. Veynar

(74) *Attorney, Agent, or Firm*—Kirschstein, et al.

(57) **CLAIM**

The ornamental design for a payment terminal, as shown and described.

DESCRIPTION

FIG. 1 is a front and left side, perspective view of a payment terminal according to the design of my invention; FIG. 2 is a rear and left side, perspective view thereof; FIG. 3 is a top plan view thereof; FIG. 4 is a front elevational view thereof; FIG. 5 is a left side elevational view thereof, the right side being a mirror image; FIG. 6 is a rear elevational view thereof; and, FIG. 7 is a bottom plan view thereof.

1 Claim, 7 Drawing Sheets

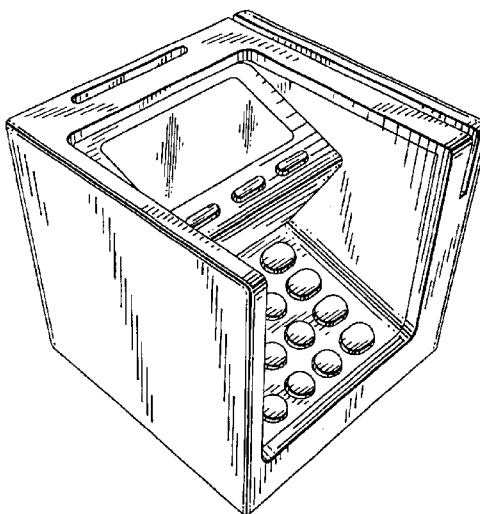

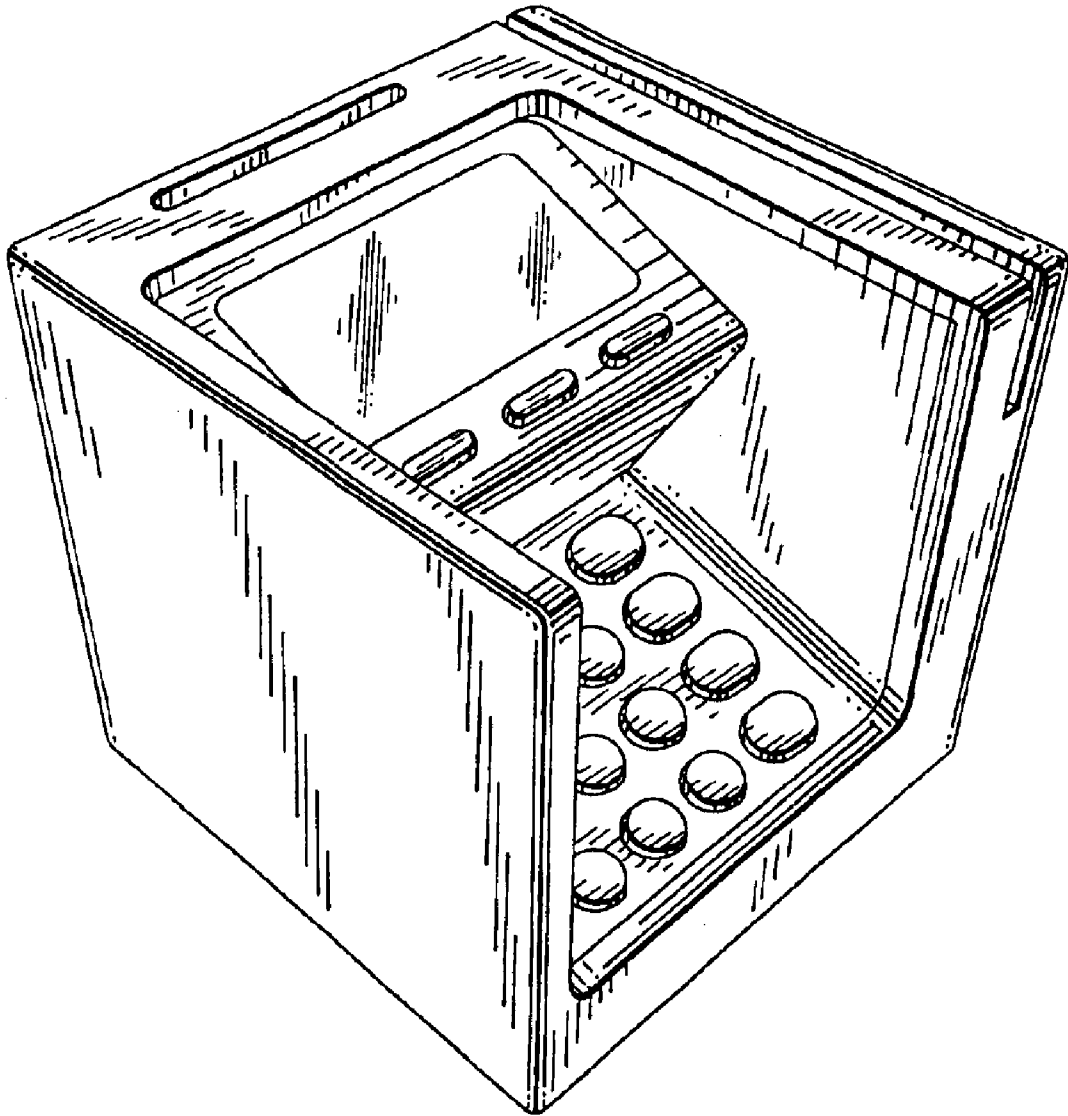

FIG. 1

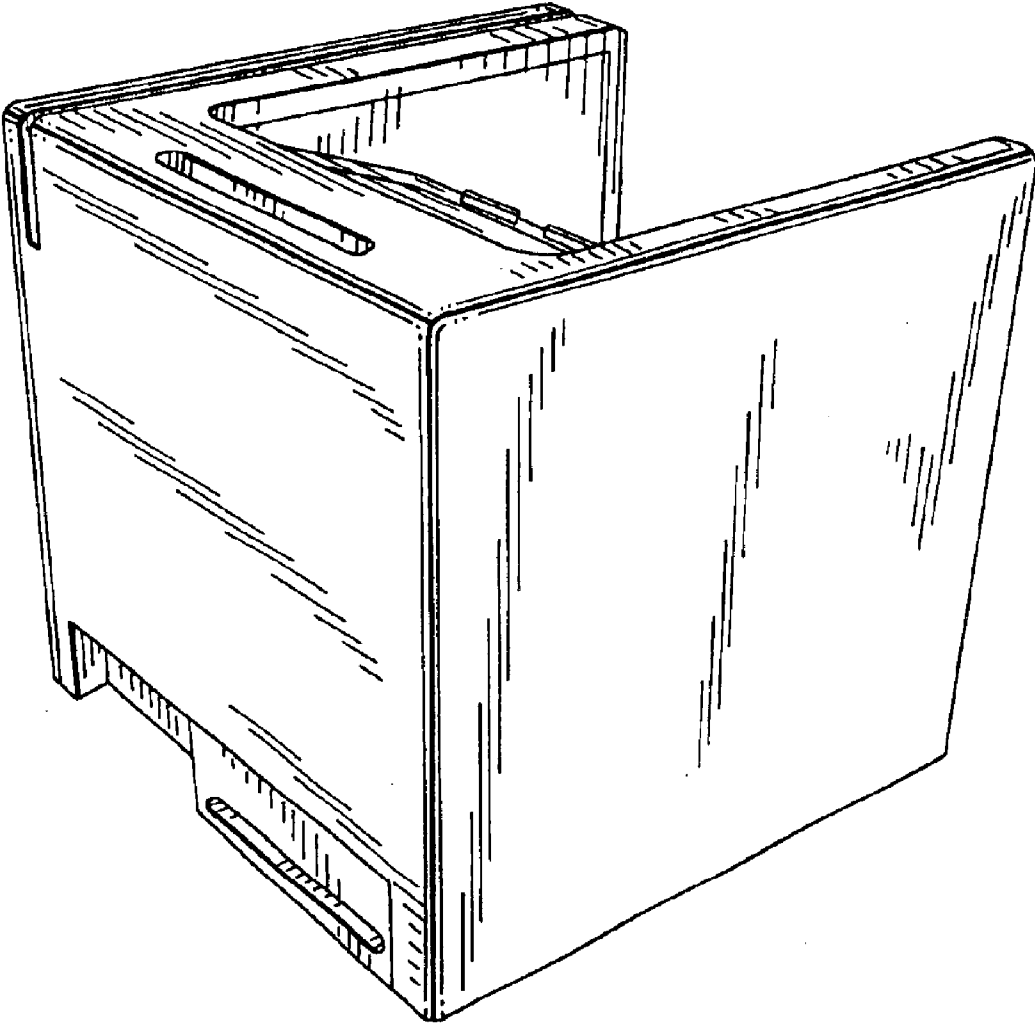

FIG. 2

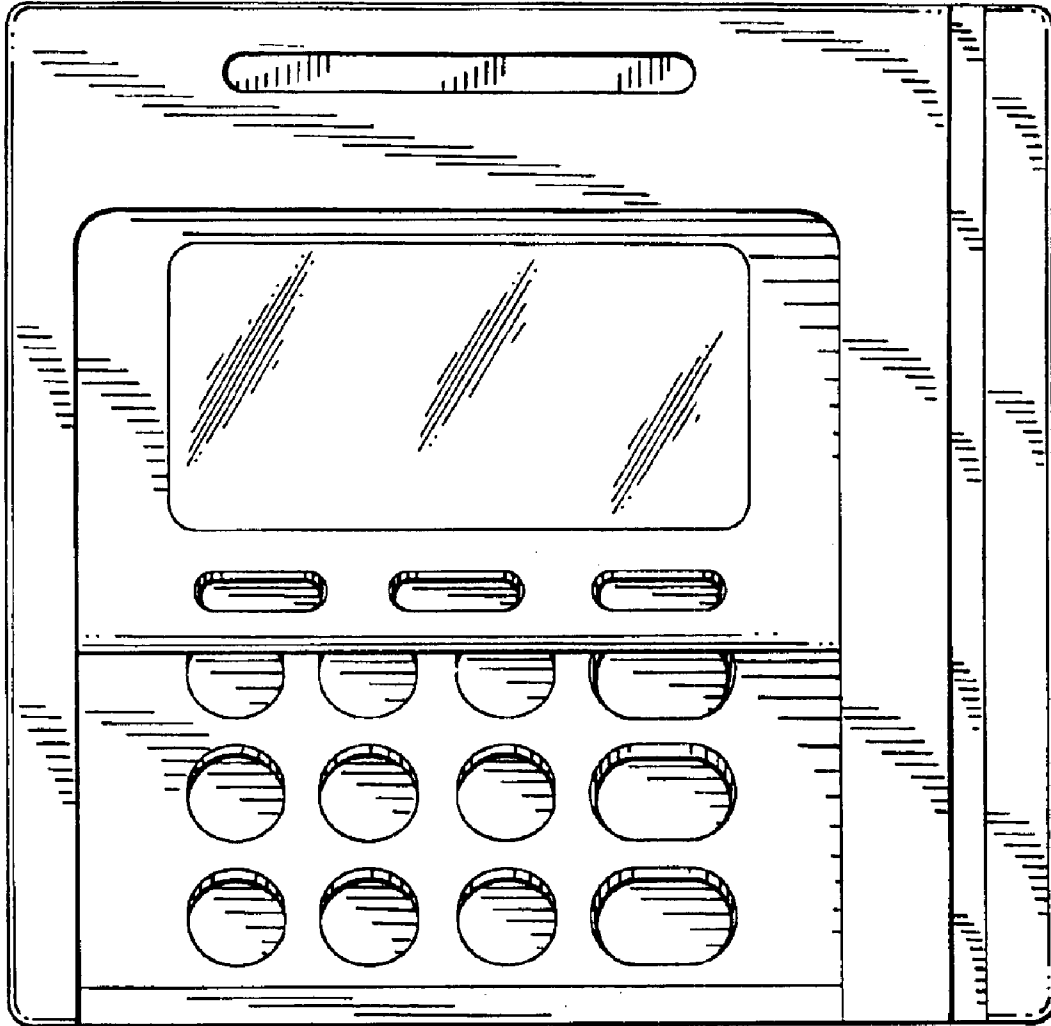

FIG. 3

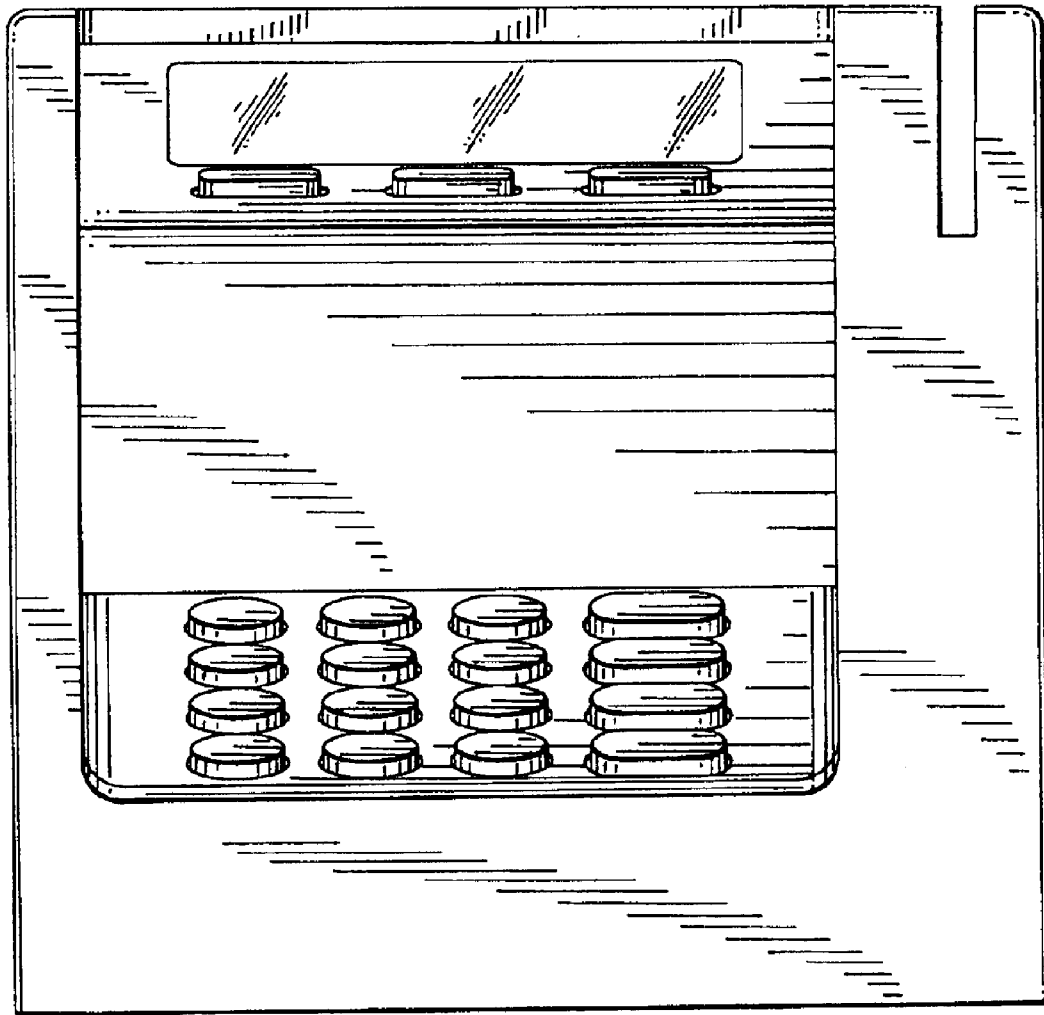

FIG. 4

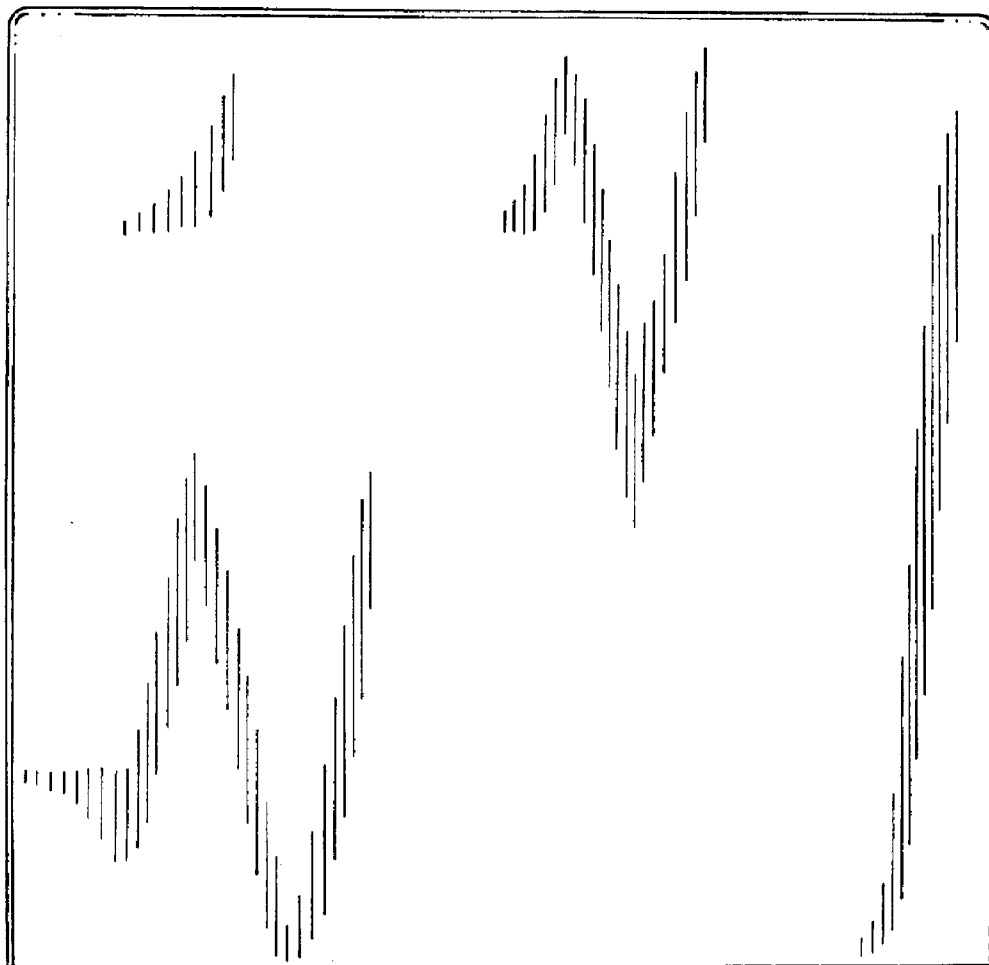

FIG. 5

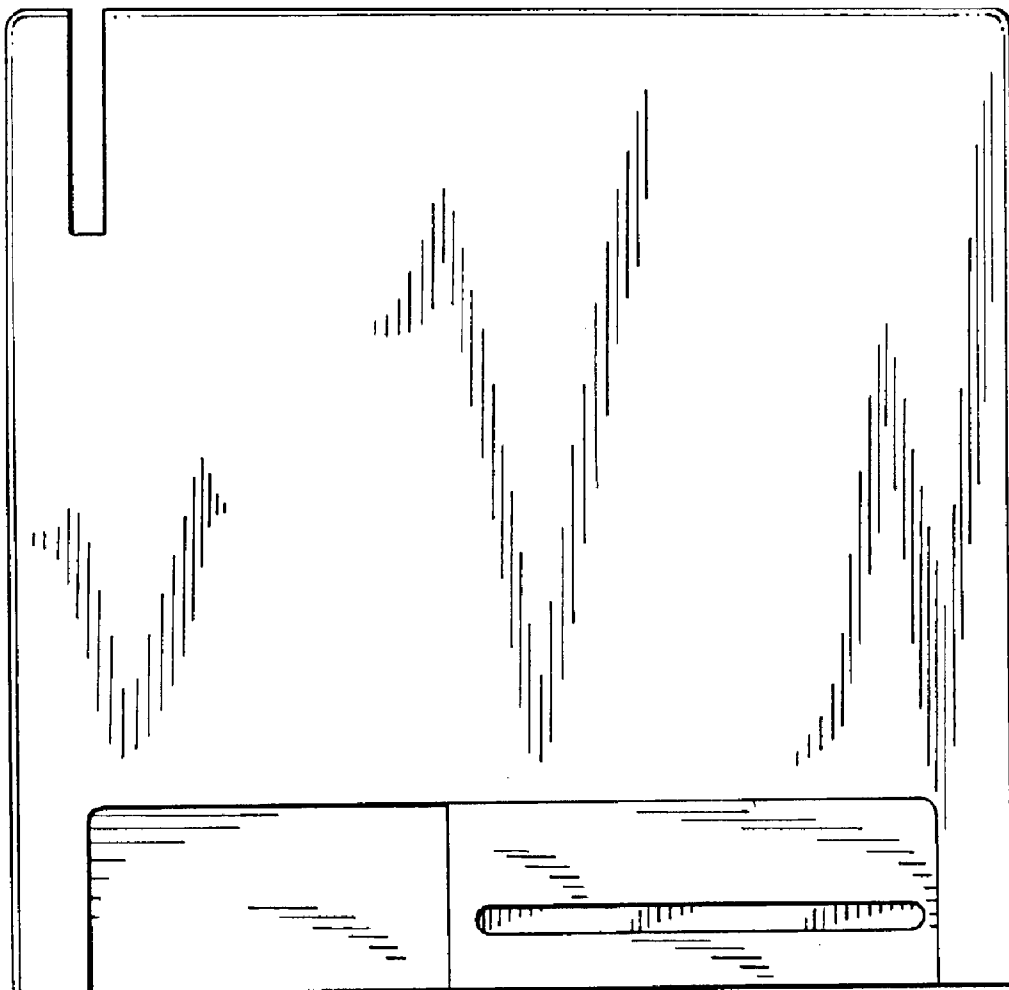

FIG. 6

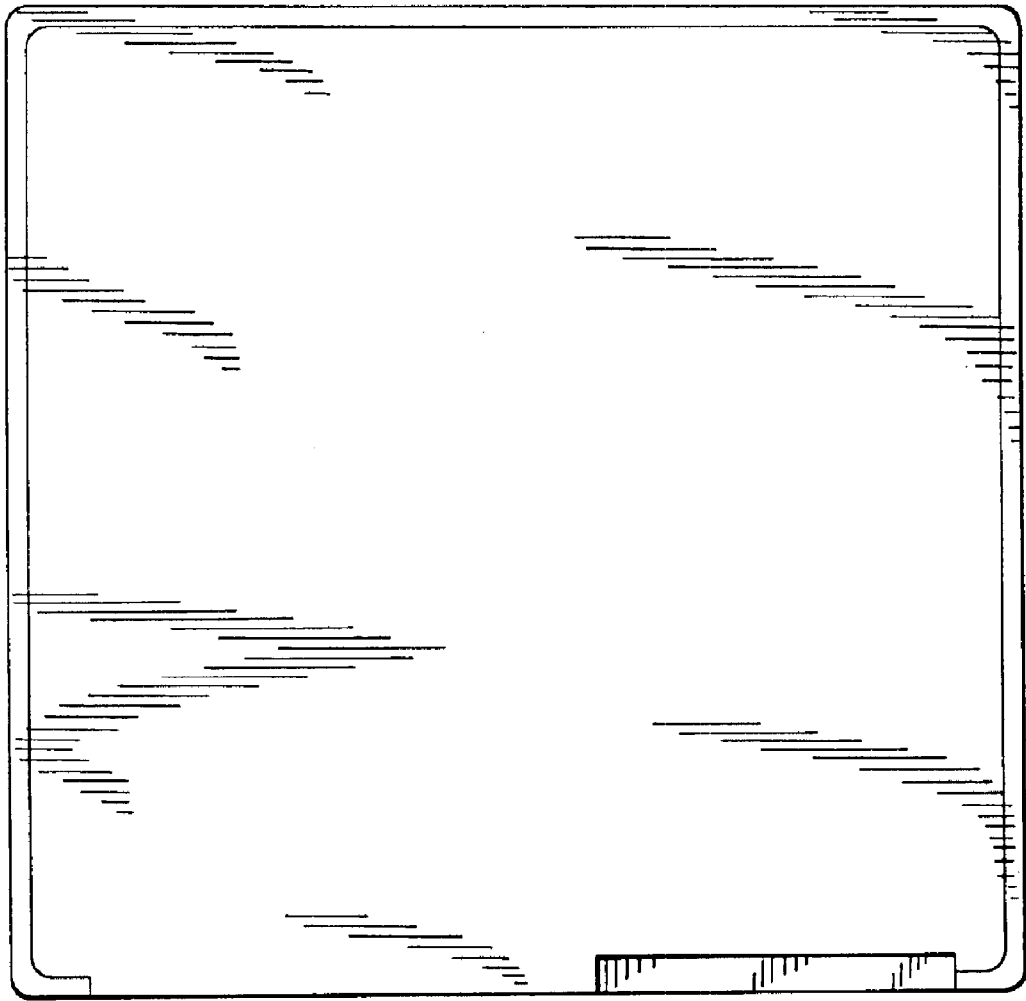

FIG. 7