

(19) World Intellectual Property Organization
International Bureau



(43) International Publication Date
12 September 2008 (12.09.2008)

PCT

(10) International Publication Number
WO 2008/108671 A1

(51) International Patent Classification:

<i>B07C 5/38</i> (2006.01)	<i>B65G 49/00</i> (2006.01)
<i>B65G 47/14</i> (2006.01)	<i>B65G 1/137</i> (2006.01)
<i>B65G 47/52</i> (2006.01)	<i>B65G 47/34</i> (2006.01)
<i>B07C 5/00</i> (2006.01)	<i>B65G 37/00</i> (2006.01)
<i>B65G 47/32</i> (2006.01)	<i>B65G 47/48</i> (2006.01)

(81) Designated States (unless otherwise indicated, for every kind of national protection available): AE, AG, AL, AM, AO, AT, AU, AZ, BA, BB, BG, BH, BR, BW, BY, BZ, CA, CH, CN, CO, CR, CU, CZ, DE, DK, DM, DO, DZ, EC, EE, EG, ES, FI, GB, GD, GE, GH, GM, GT, HN, HR, HU, ID, IL, IN, IS, JP, KE, KG, KM, KN, KP, KR, KZ, LA, LC, LK, LR, LS, LT, LU, LY, MA, MD, ME, MG, MK, MN, MW, MX, MY, MZ, NA, NG, NI, NO, NZ, OM, PG, PH, PL, PT, RO, RS, RU, SC, SD, SE, SG, SK, SL, SM, SV, SY, TJ, TM, TN, TR, TT, TZ, UA, UG, US, UZ, VC, VN, ZA, ZM, ZW.

(21) International Application Number:

PCT/NZ2008/000047

(22) International Filing Date: 7 March 2008 (07.03.2008)

(25) Filing Language: English

(26) Publication Language: English

(30) Priority Data:

553707 7 March 2007 (07.03.2007) NZ

(71) Applicant (for all designated States except US): **IBEX TECHNOLOGIES LIMITED** [NZ/NZ]; 3/9 Allens Road, East Tamaki, Auckland, 2013 (NZ).

(72) Inventor; and

(75) Inventor/Applicant (for US only): **ENGLE, Jonathan** [NZ/NZ]; 7 Muir Road, Remuera, Auckland, 1050 (NZ).

(74) Agent: **ENSOR, Donald, Rivers**; 111 Western Springs Road, Mt Albert, Auckland, 1022 (NZ).

(84) Designated States (unless otherwise indicated, for every kind of regional protection available): ARIPO (BW, GH, GM, KE, LS, MW, MZ, NA, SD, SL, SZ, TZ, UG, ZM, ZW), Eurasian (AM, AZ, BY, KG, KZ, MD, RU, TJ, TM), European (AT, BE, BG, CH, CY, CZ, DE, DK, EE, ES, FI, FR, GB, GR, HR, HU, IE, IS, IT, LT, LU, LV, MC, MT, NL, NO, PL, PT, RO, SE, SI, SK, TR), OAPI (BF, BJ, CF, CG, CI, CM, GA, GN, GQ, GW, ML, MR, NE, SN, TD, TG).

Declaration under Rule 4.17:

— of inventorship (Rule 4.17(iv))

Published:

— with international search report
— with amended claims

Date of publication of the amended claims:

13 November 2008

(54) Title: RECIRCULATING SORTING SYSTEM

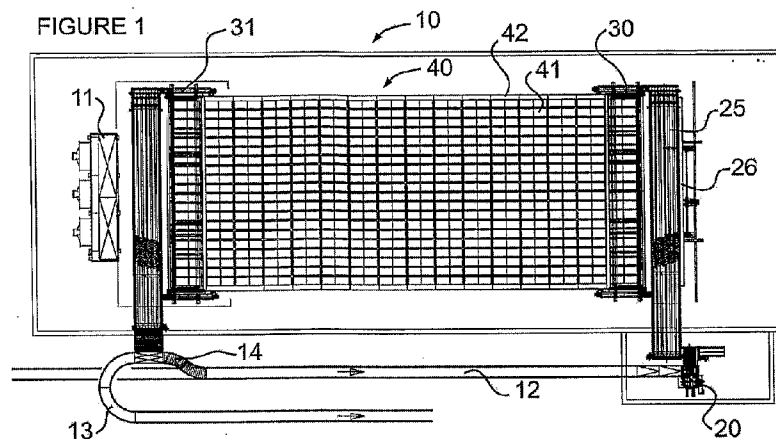

(57) Abstract: The apparatus is for sorting a range of machine-identifiable items received in random order such as meat products or cuts produced at an abattoir. In one example, the items are allocated into high, medium and low priority types (total 205 types). High priority items are allowed a smaller range of types than are low-priority items. Items are recirculated automatically for re-sorting once, twice or three times respectively into fully sorted sets of products. Preferably a freezing chamber surrounds the sorting apparatus so that the items become chilled or frozen while being sorted.

WO 2008/108671 A1

AMENDED CLAIMS**received by the International Bureau on 10 September 2008 (10.09.2008)**

1: Recirculating sorting apparatus, characterised in that the apparatus includes: a first or infeed conveyor capable of bringing identifiable items to recognition apparatus comprising a part of a controlling computer system that is capable of identifying said identifiable items and causing said identifiable items to be delivered by a first transfer means
385 to a selected shelf of a first, smaller array of two or more sorting shelves thereby forming a set of at least partially sorted items on any one sorting shelf; a second, larger array of deep holding shelves having a combined width comprised of a plurality of shelves and a combined height comprised of a plurality of levels; second transfer means capable of transferring a set of at least one item from a selected sorting shelf to a selected holding shelf;
390 and third transfer means capable of selectively carrying and delivering a set of at least one item from a selected holding shelf either to a second (outfeed) conveyor, or to a third (recirculating) conveyor capable of selectively recirculating said sets of items to the recognition apparatus, so that any set that is incompletely sorted after an earlier pass through the recirculating sorting apparatus becomes more completely sorted after a later pass.

395 2: Apparatus as claimed in claim 1, characterised in that any one sorting shelf of the first array is as long as the combined width of all shelves at one level of the second array and the second transfer means includes means capable of lifting or lowering any one selected shelf of the first array into alignment with and adjacent a selected level of the second array, so that when in use a selected set of at least one item or items is transferred from a part along a
400 sorting shelf and into a holding shelf.

3: Apparatus as claimed in claim 1, characterised in that any one sorting shelf of the first array includes means capable of horizontally moving the sorting shelf along the level of the second array so that any part of the sorting shelf may be aligned with a selected holding shelf of the second array.

405 4: Apparatus as claimed in claim 2, characterised in that any one holding shelf has a finite depth or length so that when a selected set of at least one item or items is transferred into a first end of a holding shelf, other items already on the holding shelf are pushed towards a second end of the holding shelf, so that when in use items become accessible to the third

transfer means.

- 410 5: Apparatus as claimed in claim 4, characterised in that the rack of holding shelves is placed within temperature-moderating means, such that the temperature of the items is adjusted and/or moderated while held on said holding shelves.
- 6: Apparatus as claimed in claim 5, characterised in that the temperature-moderating means includes a chamber holding the recirculating sorting apparatus and a refrigerated blower
415 capable of chilling the items on the holding shelves.
- 7: Apparatus as claimed in claim 6, characterised in that the refrigerated blower is capable of freezing the items on the holding shelves.
- 8: Apparatus as claimed in claim 1, characterised in that the first array of sorting shelves includes from two to at least ten sorting shelves.
- 420 9: A method for sorting items using recirculating sorting apparatus as claimed in claim 1, characterised in that the method includes the steps of:
- (a) taking a plurality of types of item to be sorted and allocating a predetermined sorting priority to each type, wherein a higher priority includes a smaller number of types than does a lower priority;
- 425 (b) ascertaining the type of item and physical position of each of an unsorted plurality of incoming items carried past a recognition means at a rate of delivery on an input conveyor and subsequently maintaining knowledge of the position of each item while within the apparatus, thereby giving each item an identity and a priority while within the apparatus;
- (c) quickly causing each item to be placed upon a selected shelf (herein referred to as
430 the "first shelf") of the first, smaller array of sorting shelves according to the sorting priority assigned to that type of item, thereby carrying out a first priority-based sorting procedure;
- (d) causing each item to be transferred from said first shelf to a selected horizontal position along a selected shelf (herein referred to as the "second shelf") of the second, larger array of deep holding shelves; the shelf being selected according to the sorting priority

435 assigned to that item and the horizontal position being selected according to the identity of that item, thereby carrying out a second at least partial sorting procedure for which sorting will be completed faster for those items having a higher sorting priority, thereby carrying out a second, combined priority-based and identity-based sorting procedure;

(e) and accumulating said identified items as sets within the or each second shelf until
440 a command is received for delivery of items of a specified identity out of the apparatus; thereupon causing the third transfer means to deliver the specified items from the second shelf on to the second (outfeed) conveyor);

(f) meanwhile, during downtime periods when the rate of delivery of items is small; commencing a re-sorting process wherein one or more sets of items held within the or each
445 second shelf that are partially sorted are transferred by the third transfer means on to the third (recirculating) conveyor and back to the input conveyor so as to become more completely sorted into separated types of item by means of at least one repeated pass through the apparatus.

10: A method as claimed in claim 9 for sorting items using recirculating sorting apparatus
450 wherein the method provides that the range of numbers T of types of item that may be allocated to the Xth predetermined sorting priority depends on the number of shelves N in the first, smaller array of sorting shelves and is expressed as

the function : $1 \rightarrow T \rightarrow N^X$, where X is less than or equal to N.

11: An automated method for sorting items using recirculating sorting apparatus as claimed
455 in claim 9 wherein the method is carried out in a temperature-moderated environment.

12: A method as claimed in claim 9 characterised in that the configuration provides for N -1 separate high-priority items to be separated from an incoming stream; all the remainder being left in an unsorted group until after one or more recirculations through the recirculating sorting apparatus; where N is a function of the number of sorting shelves.

460 13: A method as claimed in claim 9 characterised in that the configuration provides for N customer-directed collections of items; each collection being completely sorted after one or

more recirculations through the recirculating sorting apparatus; where N is a function of the number of sorting shelves.