



(86) Date de dépôt PCT/PCT Filing Date: 2015/02/20
 (87) Date publication PCT/PCT Publication Date: 2016/08/25
 (85) Entrée phase nationale/National Entry: 2017/06/20
 (86) N° demande PCT/PCT Application No.: US 2015/016846
 (87) N° publication PCT/PCT Publication No.: 2016/133539

(51) Cl.Int./Int.Cl. *E21B 34/06* (2006.01),
E21B 33/13 (2006.01)
 (71) Demandeur/Applicant:
HALLIBURTON ENERGY SERVICES, INC., US
 (72) Inventeur/Inventor:
STAIR, TODD ANTHONY, US
 (74) Agent: NORTON ROSE FULBRIGHT CANADA
LLP/S.E.N.C.R.L., S.R.L.

(54) Titre : ENSEMBLE DE VANNE DE REMPLISSAGE DIFFERENTIELLE POUR TROU TUBE
 (54) Title: DIFFERENTIAL FILL VALVE ASSEMBLY FOR CASED HOLE

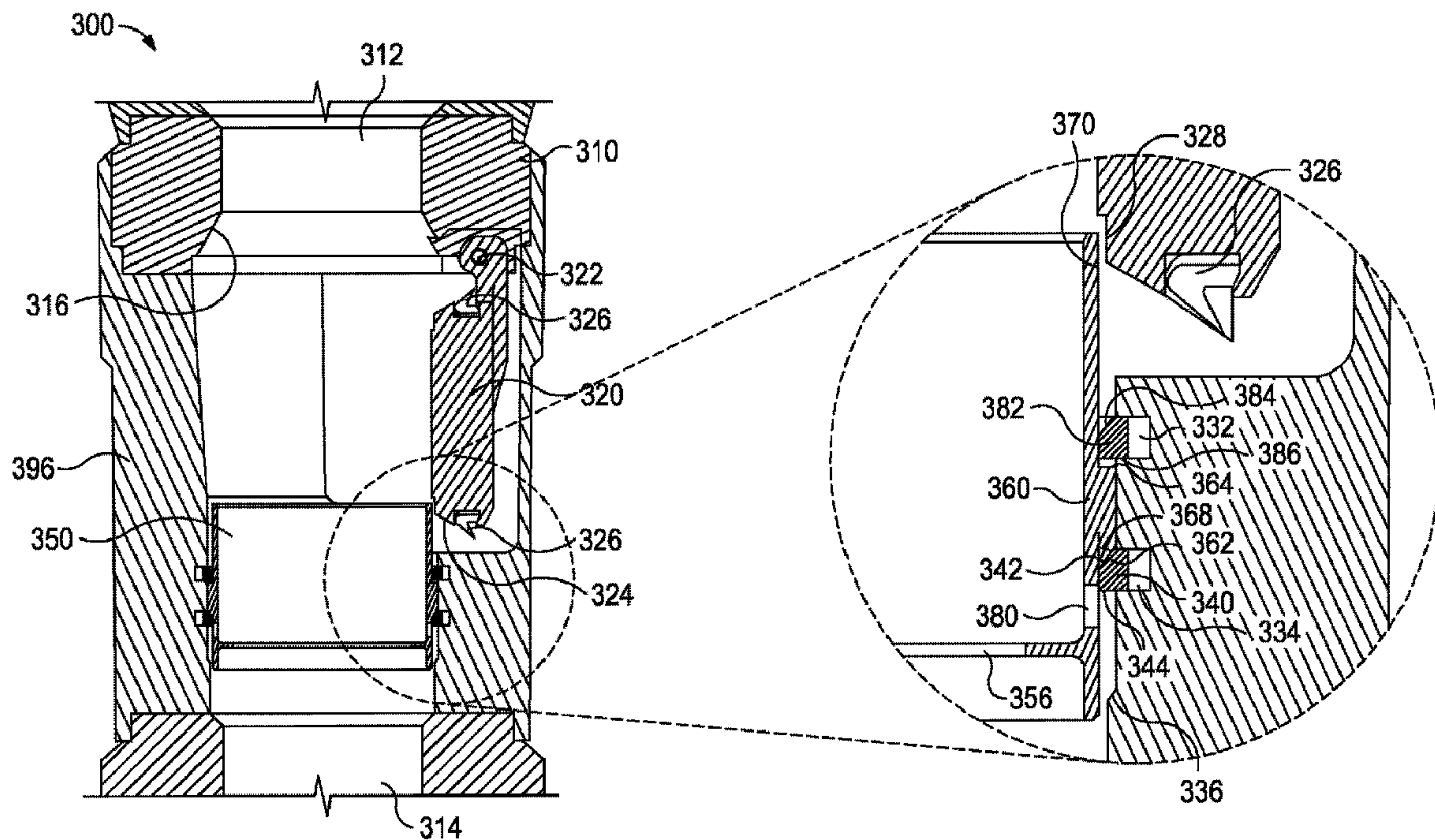

FIG. 3A

(57) Abrégé/Abstract:

A differential fill valve assembly for application in float collars or shoes in a well casing can provide locking mechanisms to limit premature movement of an activating sleeve while facilitating desired advancement of the activating sleeve. The valve assembly

(57) **Abrégé(suite)/Abstract(continued):**

comprises a backpressure flapper valve and an activating sleeve slidably disposed within a housing. The activating sleeve initially maintains the flapper valve in an open position while the activating sleeve is maintained in its position by upper and/or lower lock rings on either side of a shoulder of the activating sleeve. A tripping ball is dropped to seat in the activating sleeve. Pressure applied on the ball moves the activating sleeve downward, releasing the backpressure flapper valve, after which the tripping ball exits the bottom of the assembly. The lower lock ring maintains the activating sleeve in its lower position.

(12) INTERNATIONAL APPLICATION PUBLISHED UNDER THE PATENT COOPERATION TREATY (PCT)

(19) World Intellectual Property
Organization
International Bureau(43) International Publication Date
25 August 2016 (25.08.2016)(10) International Publication Number
WO 2016/133539 A1

(51) International Patent Classification:

E21B 34/06 (2006.01) *E21B 33/13* (2006.01)

(21) International Application Number:

PCT/US2015/016846

(22) International Filing Date:

20 February 2015 (20.02.2015)

(25) Filing Language:

English

(26) Publication Language:

English

(71) Applicant: **HALLIBURTON ENERGY SERVICES, INC.** [US/US]; 3000 N. Sam Houston Parkway E., Houston, Texas 77032-3219 (US).(72) Inventor: **STAIR, Todd Anthony**; 30531 Woodson Trace Drive, Spring, Texas 77386 (US).(74) Agents: **KAISER, Iona et al.**; McDermott Will & Emery LLP, 500 North Capitol Street, N.W., Washington, District of Columbia 20001 (US).(81) Designated States (*unless otherwise indicated, for every kind of national protection available*): AE, AG, AL, AM, AO, AT, AU, AZ, BA, BB, BG, BH, BN, BR, BW, BY, BZ, CA, CH, CL, CN, CO, CR, CU, CZ, DE, DK, DM,

DO, DZ, EC, EE, EG, ES, FI, GB, GD, GE, GH, GM, GT, HN, HR, HU, ID, IL, IN, IR, IS, JP, KE, KG, KN, KP, KR, KZ, LA, LC, LK, LR, LS, LU, LY, MA, MD, ME, MG, MK, MN, MW, MX, MY, MZ, NA, NG, NI, NO, NZ, OM, PA, PE, PG, PH, PL, PT, QA, RO, RS, RU, RW, SA, SC, SD, SE, SG, SK, SL, SM, ST, SV, SY, TH, TJ, TM, TN, TR, TT, TZ, UA, UG, US, UZ, VC, VN, ZA, ZM, ZW.

(84) Designated States (*unless otherwise indicated, for every kind of regional protection available*): ARIPO (BW, GH, GM, KE, LR, LS, MW, MZ, NA, RW, SD, SL, ST, SZ, TZ, UG, ZM, ZW), Eurasian (AM, AZ, BY, KG, KZ, RU, TJ, TM), European (AL, AT, BE, BG, CH, CY, CZ, DE, DK, EE, ES, FI, FR, GB, GR, HR, HU, IE, IS, IT, LT, LU, LV, MC, MK, MT, NL, NO, PL, PT, RO, RS, SE, SI, SK, SM, TR), OAPI (BF, BJ, CF, CG, CI, CM, GA, GN, GQ, GW, KM, ML, MR, NE, SN, TD, TG).

Declarations under Rule 4.17:

— *as to applicant's entitlement to apply for and be granted a patent (Rule 4.17(ii))*

Published:

— *with international search report (Art. 21(3))*

(54) Title: DIFFERENTIAL FILL VALVE ASSEMBLY FOR CASED HOLE

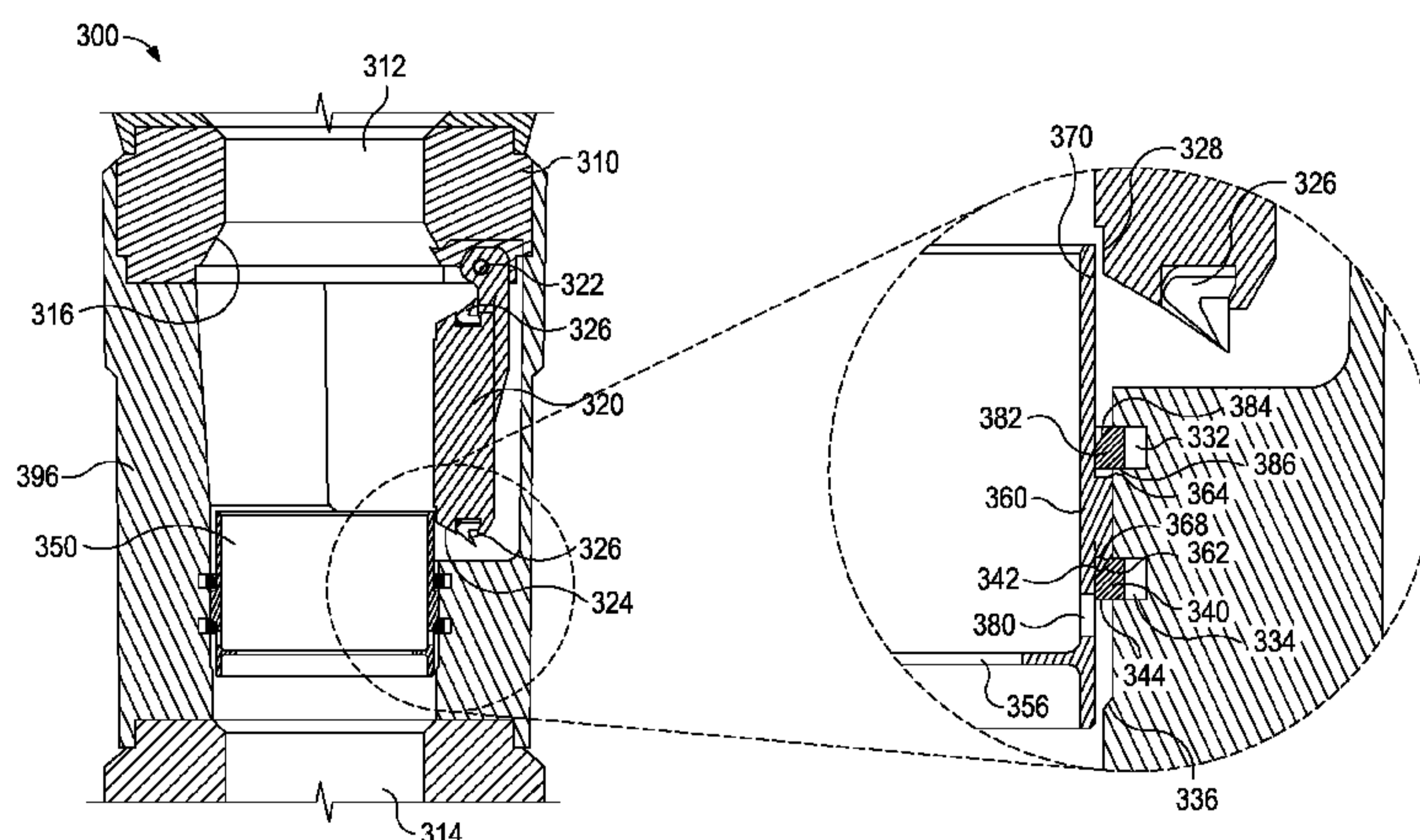

FIG. 3A

(57) Abstract: A differential fill valve assembly for application in float collars or shoes in a well casing can provide locking mechanisms to limit premature movement of an activating sleeve while facilitating desired advancement of the activating sleeve. The valve assembly comprises a backpressure flapper valve and an activating sleeve slidably disposed within a housing. The activating sleeve initially maintains the flapper valve in an open position while the activating sleeve is maintained in its position by upper and/or lower lock rings on either side of a shoulder of the activating sleeve. A tripping ball is dropped to seat in the activating sleeve. Pressure applied on the ball moves the activating sleeve downward, releasing the backpressure flapper valve, after which the tripping ball exits the bottom of the assembly. The lower lock ring maintains the activating sleeve in its lower position.

WO 2016/133539 A1

DIFFERENTIAL FILL VALVE ASSEMBLY FOR CASED HOLE**BACKGROUND**

[0001] In the oil and gas industry, wellbores are drilled into the Earth's surface in order to access underground reservoirs for the extraction of hydrocarbons. Once a wellbore is drilled, it is often lined with casing or a string of casing sections or lengths, and the casing is then secured into place using cement. In one cementing technique, a cement composition is pumped through the interior of the casing and allowed to flow back toward the surface via the annulus defined between the wellbore wall and the casing. The cement composition within the annulus is then allowed to cure, forming a hardened mass in the annulus. In another cementing technique, commonly referred to as reverse-circulation cementing, the cement composition is pumped through the annulus to the bottom of the wellbore and then back toward the surface via the interior of the casing. Once the cement composition cures within the annulus to form a hardened mass, the casing serves to stabilize the walls of the surrounding subterranean formation to prevent any potential caving into the wellbore. The casing also isolates the various surrounding subterranean formations by preventing the flow or cross-flow of formation fluids via the annulus. The casing further provides a surface to secure pressure control equipment and downhole production equipment, such as a drilling blowout preventer (BOP) or a production packer.

[0002] When casing is being run into a wellbore, particularly where deep wells are involved, it is desirable to "float" the casing down to its intended location within the wellbore fluid to relieve some of the strain from the derrick, prior to the time the casing is cemented in the well. It is also desirable to have the casing fill automatically at a predetermined rate to save rig time.

[0003] Float valves are one-way valves (i.e., check valves) that can be installed at or near the interior bottom end of a casing string. Once operational, float valves permit fluid (such as mud or cement) to flow down through the inside of the casing while preventing fluids from flowing in the reverse direction back up the inside of the casing. By doing so, float valves prevent cement that is pumped down through the casing, into the shoe track, and up into the annular space from flowing back up through the valves once the cement is in place, an occurrence known as "reverse flow" or "u-tubing." U-tube pressure is created by

the differential hydrostatic pressure between the fluid column inside the casing and the fluid column in the annulus. In cases where the cement density is close to drilling mud density, the u-tube pressure may be very small—too small to induce backflow or to be detected at the rig.

5 **[0004]** Float shoes and float collars have been developed, which permit automatic filling of the casing and incorporate a backpressure valve to prevent cement back flow into the casing after the cementing operation. Certain backpressure valves also permit the option of terminating the filling of the casing at any point in time. During the insertion of casing into the wellbore, a
10 traditional auto-fill, flapper-type float valve is held open by a pin set across a sleeve in the valve assembly bore. As the casing enters the wellbore, the preset spring tension of the flapper valve spring allows controlled filling of the casing to a predetermined differential pressure between the casing interior and the wellbore annulus. Fluid may be circulated through the casing at any time due to
15 the presence of the circulating flapper valve. When it is desired to actuate the backpressure valve to prevent further filling of the casing as it is being run in, or after circulation has been established prior to initiating of the cementing operation for the casing, a weighted tripping ball is dropped, or carried in with the float valve, which breaks the pin holding the sleeve and thereby freeing the
20 flapper valve to close. After cementing has been completed, the released flapper valve prevents cement flow back into the casing from the wellbore annulus. Due to the close operating pressures of the float valve, premature release of the flapper valve can occur. Additionally, the same operating conditions can cause the flapper valve to not release entirely.

25

BRIEF DESCRIPTION OF THE DRAWINGS

[0005] The following figures are included to illustrate certain aspects of the present disclosure, and should not be viewed as exclusive embodiments. The subject matter disclosed is capable of considerable modifications,
30 alterations, combinations, and equivalents in form and function, without departing from the scope of this disclosure.

[0006] FIG. 1A illustrates a cross-sectional side view of a wellbore system that may employ one or more principles of the present disclosure.

[0007] FIG. 1B illustrates a cross-sectional side view of a differential fill
35 valve assembly of the present disclosure, employed in a casing float collar.

[0008] FIGS. 2A-2C illustrate a cross-sectional side view of an exemplary differential fill valve assembly, in an unactuated state (FIG. 2A), an actuated state (FIG. 2B), and a reopened state (FIG. 2C).

[0009] FIGS. 3A-3D illustrate a cross-sectional side view of an exemplary differential fill valve assembly, in an unactuated state (FIG. 3A),
5 partially actuated states (FIG. 3B-C), and a fully actuated state (FIG. 3D).

DETAILED DESCRIPTION

[0001] The present disclosure is related to downhole tools and, more particularly, to the operation of downhole tools during wellbore cementing
10 operations.

[0002] Traditional fill equipment typically utilizes a match-drilled hole that is pinned with a small diameter brass pin. The pin can be peened and ground flush with the ID of the activation sleeve. These production steps
15 introduce opportunities for errors during assembly, which could produce operational issues. The match-drilled hole and pinning adds considerable time and cost to the assembly of the tool. Moreover, the brass pin may cause premature shifting of the sleeve, or may disable the sleeve from shifting entirely. When a ball lands on the lip of the sleeve, the pin is sheared and the sleeve
20 moves downward. Later, the ball extrudes through the lip. Often, the flow rate of fluid moving past the sleeve does not generate sufficient force to move the sleeve, even when unpinned.

[0003] The exemplary differential fill valve assemblies disclosed herein provide a mechanism for positive retention of a backpressure valve in an open
25 mode during run-in of the casing, a mechanism for activating a valve during operation, and a mechanism to maintain the valve in an actuated state during operation.

[0004] The differential fill valve assembly of the present disclosure includes a backpressure flapper valve disposed within a substantially tubular
30 upper housing, and a lower housing containing a slidably disposed activating sleeve therein above a double flapper valve having a fillup flapper valve mounted on a larger, circulating flapper valve, which is attached to the lower housing.

[0005] As casing is run into the wellbore, the valve assembly of the
35 subject technology is located in a float collar or float shoe, or both, in the casing.

The activating sleeve holds the backpressure flapper in an open mode, and is itself maintained in position through use of locking rings. When desired, the backpressure valve can be activated by dropping a weighted tripping ball, which will contact a seat in the bore of the activating sleeve, causing a pressure
5 buildup above the ball, which will drive the activating sleeve downwardly. As the activating sleeve moves downward, the backpressure valve is released. An additional lock ring maintains the activating sleeve in its lower position after the tripping ball is extruded through the tool.

[0006] The exemplary valve assemblies of the present disclosure allow
10 the activating sleeve to be held in place prior to entry of the weighted tripping ball. The activating sleeve can be held in place without the use of shear pins or other mechanisms that require greater force to shear a pin before moving the activating sleeve and releasing the backpressure valve. Mechanisms disclosed herein provide stable securement of the activating sleeve as well as
15 predetermined activation requirements for activating the sleeve and releasing the backpressure valve. Operational consistency is enhanced by maintaining a high retaining force during circulation and requiring only a low pressure to shift the sleeve once the ball seats on the lip.

[0007] Referring to FIG. 1A, illustrated is a cross-sectional side view of
20 a wellbore system 100 that may employ one or more of the principles of the present disclosure. More particularly, FIG. 1A depicts a wellbore 102 that has been drilled into the Earth's surface 104 and a surface casing 106 secured within the wellbore 102 and extending from the surface 104. A wellhead installation 108 is depicted as being arranged at the surface 104 and a casing string 110 is
25 suspended within the wellbore 102 from the wellhead installation 108. A casing shoe 112 may be attached at the bottom-most portion of the casing string 110, and an annulus 114 is defined between the wellbore 102 and the casing string 110.

[0008] As used herein, the term "casing string," as in the casing string
30 110, may refer to a tubular casing length extending through a wellbore that may include a plurality of tubular casing lengths coupled (*e.g.*, threaded) together to form a continuous tubular conduit of a desired length. It will be appreciated, however, that the casing string 110 may equally refer to a single tubular length or structure, without departing from the scope of the disclosure.

[0009] At the surface 104, a feed line 116 may be operably and fluidly coupled to the wellhead installation 108 and in fluid communication with an interior 118 of the casing string 110. The feed line 116 may have a feed valve 120 configured to regulate the flow of cement 122 into the interior 118 of the casing string 110, and the feed line 116 may be fluidly coupled to a source 124 of cement 122. In the depicted embodiment, the source 124 of the cement 122 is a cement truck, but could equally be a cement head, a standalone pump, or any other pumping mechanism known to persons skilled in the art and capable of introducing the cement 122 into the interior 118 of the casing string 110. A return line 126 may also be connected to the wellhead installation 108 and in fluid communication with the annulus 114. In some cases, as illustrated, the return line 126 may include a return valve 128 configured to regulate the flow of fluids returning to the surface 104 via the annulus 114.

[0010] In order to secure the casing string 110 within the wellbore 102, cement 122 may be pumped from the source 124 and into the interior 118 of the casing string 110 via the feed line 116. The cement 122 flows to the bottom of the casing string 110 and is diverted at the casing shoe 112 back toward the surface 104 within the annulus 114.

[0011] Referring to FIG. 1B, with continued reference to FIG. 1A, a differential fill valve assembly 200 may be provided within a float collar 136 of a casing string 110. The float collar 136 can be suspended in a wellbore from upper casing 132, having a bore 142. Float collar 136 can include a generally cylindrical tubing section, which can interface with the upper casing 132 by a mating interface (e.g., threads, etc.). A collar 136 can be attached at its lower end to lower casing 134, having a bore 144, by another mating interface (e.g., threads, etc.). The float collar 136 has a substantially uniform inner diameter at an inner surface thereof to hold cement casting 140 in place. The differential fill valve assembly 200 may be securely maintained in place, relative to the float collar 136, by the cement casting 140.

[0012] Referring to FIGS. 2A-2C, the valve assembly 200 can include a substantially tubular upper housing 210 defining an axial entry bore 212. Below entry bore 212, a frustoconical bore wall 216 can extend radially outward to a larger diameter in the downward direction. The interior of the lower housing 296 also forms a frustoconical surface 236 that tapers from an upper, larger diameter bore wall to a lower, smaller diameter bore wall.

[0013] A backpressure flapper 220 may be provided on one side of the valve assembly 200. The flapper 220 is pivotable on a pin 222, and is biased toward a closed position by a torsion spring, or other biasing mechanism, acting thereupon. In some embodiments, one surface of the flapper 220 can include a slight annular undercut surface 228 at its periphery to engage an outer wall 270 of the sleeve 250. An outwardly flaring frustoconical surface 224 extends from the surface 228 to an elastomeric seal 226. The elastomeric seal 226 can extend annularly and provide a flexible lip at an outer extent thereof.

[0014] An activating sleeve 250 is slidably contained within the lower housing 296, and can include an annular lip 256 extending from an inner wall thereof. The annular lip 256 can have an inner cross-sectional dimension (e.g., a diameter) that is smaller than an outer cross-sectional dimension (e.g., a diameter) of a weighted tripping ball 299 (FIG. 2B), as described further herein. The annular lip 256 may be flexible and otherwise configured to bend, expand, or bow radially outwardly upon application of a force corresponding to a predetermined threshold, as described further herein. The exterior of the activating sleeve 250 provides an annular shoulder 260 having a radially flat upper face and a frustoconical lower face. One or more ports 280 extend through the wall of activating sleeve 250 from a radially outer wall 270 of the activating sleeve 250 to a radially inner surface of the activating sleeve 250.

[0015] According to some embodiments, the activating sleeve 250 can be initially secured to lower housing 296 by one or more shear fasteners 292 that extend into corresponding apertures defined in the annular shoulder 260. The shear fastener 292 can extend from a first radial side of the annular shoulder 260 through the lower housing 296 and the shoulder 260. The shear fastener 292 can be peened and ground flush with the inner diameter of the activation sleeve 250.

[0016] According to some embodiments, a split lock ring 240 surrounds an exterior surface of the activating sleeve 250, and is contained within an annular recess 234. An upper inner frustoconical surface of the lock ring 240 is configured to flare upwardly and radially outwardly. A lower surface can extend in a radial plane.

[0017] With continued reference to FIGS. 1A-2C, exemplary operation of the valve assembly 200 will now be provided, according to one or more embodiments.

[0018] Differential fill float collar 136, as previously noted, is run into the open wellbore as suspended from the casing 132. The wellbore is generally filled with fluid such as drilling mud, and the casing is thereby "floated" into the wellbore. The casing bore 142 above the differential fill float collar 136 is filled with wellbore fluid at a gradual rate, so that the casing 132 above float collar 136 is only partially filled and "floated" into the hole, and thereby lessening strain on the derrick that introduces the casing 132 downhole. The fluid level above float collar 136 will thus be below that outside the casing. More particularly, the difference in fluid level is a function of the weight of the drilling fluid and the fillup spring size and the fillup spring may be selected to provide a desired fill rate.

[0019] While the casing is being run, the top end of activating sleeve 250 maintains backpressure flapper 220 in an open position. Consequently, circulation can be established at any time during the running of the casing without releasing activating sleeve 250.

[0020] As shown in FIG. 2B, a weighted tripping ball 299 may be dropped down the casing bore 142 until locating and landing on the annular lip 256 defined within the activating sleeve 250. The pressure above the ball 299 will build until shear pin 292 shears (if installed), and activating sleeve 250 will travel downward releasing backpressure flapper 220. Activating sleeve 250 can be prevented from rotating by the shear fastener 292.

[0021] As shown in FIG. 2C, after the activating sleeve 250 reaches the full extent of its travel, ball 299 can extended past the annular lip 256 and be pumped out of the float collar 136 to the bottom of the wellbore. Ports 280 in the wall of activating sleeve 250 permit any fluid trapped near the annular shoulder 260 of the activating sleeve 250 to escape when the activating sleeve 250 moves down. The activating sleeve 250 is prevented from moving back to its original position by the lock ring 240. More specifically, as the shoulder 260 on activating sleeve 250 contacts the frustoconical upper face on the lock ring 240, the lock ring 240 is forced apart and over the shoulder 260 so that when differential pressure is released (as when ball 299 leaves the float collar 136), the radially flat lower face of the lock ring 240 will engage the shoulder 260 of the activating sleeve 250.

[0022] As the cementing operation is performed, the released backpressure flapper 220 is able to control any back flow of cement up into

casing bore 142, as the elastomeric seal 226 seats on the annular surface 216 of the upper housing 210 as the hydrostatic pressure in the casing bore 144 and the force of the spring 222 urges the backpressure flapper 220 into a closed position. At the resumption of cement pumping, pump pressure in the casing bore 142 overcomes the spring force and hydrostatic pressure below the float collar 136, and the backpressure flapper 220 reopens.

[0023] After the cementing operation is completed, the interior components of the float collar 136 can be drilled out by means known in the art to provide an open casing bore to the bottom of the casing.

[0024] Referring now to FIGS. 3A-D, with continued reference to FIGS. 1A-1B, an exemplary valve assembly 300 can include substantially tubular upper housing 310 defining an axial entry bore 312. Below entry bore 312, a frustoconical bore wall 316 can extend radially outward to a larger diameter in a downward direction. The interior of the lower housing 396 also forms a frustoconical surface 336 that tapers from an upper, larger diameter bore wall to a lower, smaller diameter bore wall.

[0025] A backpressure flapper 320 is provided on one side of the valve assembly 300. The flapper 320 is pivoted on pin 322, and is biased toward a closed position by a torsion spring, or other biasing mechanism, acting thereupon. One surface of the flapper 320 can include a slight annular undercut surface 328 at its periphery to engage an outer wall 370 of the sleeve 350. An outwardly flaring frustoconical surface 324 extends from the surface 328 to an elastomeric seal 326. The elastomeric seal 326 can extend annularly and provide a flexible lip at an outer extent thereof.

[0026] An activating sleeve 350 is slidably contained within a lower housing 396, and can include an annular lip 356 extending from an inner wall thereof. The annular lip 356 can have an inner cross-sectional dimension (e.g., a diameter) that is smaller than an outer cross-sectional dimension (e.g., a diameter) of a weighted tripping ball 399, as described further herein. The annular lip 356 may be flexible and otherwise configured to bend, expand, or bow radially outwardly upon application of a force corresponding to a programmed threshold. One or more ports 380 extend through the wall of activating sleeve 350 from a radially outer surface of the activating sleeve 350 to a radially inner surface of the activating sleeve 350. The activating sleeve 350 can be formed from one or more of a variety of materials, including brass,

aluminum, composite materials, elastomers, and thermoplastic or thermoset polymers. Material selection for the activating sleeve 350 can provide predetermined retention of the ball 399 up to selected force limits, beyond which the annular lip 356 can be elastically or plastically deformed to allow passage of the ball 399. Material selection for the activating sleeve 350 can facilitate drilling through the valve assembly 300 at the completion of an operation.

[0027] The exterior of the activating sleeve 350 provides an annular shoulder 360 with an upper face 364 in a radial plane. For example, the upper face 364 can face axially toward the axial entry bore 312 at any point thereon. Alternatively, the upper face 364 can be frustoconical by flaring upwardly and radially outwardly. Other shapes of the upper face 364 are contemplated, such as concave and/or convex contoured surfaces. The upper face 364 can be configured to securely engage opposing and/or complementary surfaces on an upper side of the shoulder 360.

[0028] The annular shoulder 360 can further have a frustoconical lower face 362. For example, the lower face 362 can face radially outwardly and downwardly (i.e., toward the axial exit bore 314) at any point thereon. By further example, the lower face 362 can form an oblique angle relative to a longitudinal axis of the valve assembly 300. Such an angle can be selected to determine, at least in part, the force required to shift the activating sleeve 350 past a lower lock ring 340. For example, the angle can be between 10° and 80°. An exemplary lower face 362 can form an angle of about 27°. As will be appreciated, greater angles can result in a greater force being required to expand the lower lock ring 340, and smaller angles can result in a smaller force being required. The required force can be significant enough to avoid premature movement of the activating sleeve 350, yet still be less than a force required to both shear a pin and move an activating sleeve. Other shapes of the lower face 362 are contemplated, such as concave and/or convex contoured surfaces. The lower face 362 can be configured to engage and/or separate structures providing opposing and/or complementary surfaces on a lower side of the shoulder 360.

[0029] According to some embodiments, an upper split lock ring 382 surrounds an exterior surface of the activating sleeve 350, and is contained within an annular recess 332. The upper split lock ring 382 can be formed as a circumferentially discontinuous ring that can expand to increase an opening there through. Other radial locking mechanisms can be used to controllably

retain the activating sleeve 350. For example, one or more retractable protrusions, biased radially inwardly, can individually engage the shoulder 360. By further example, a radial locking mechanism can be provided to receive the activating sleeve 350 from the entry bore 312 when a force by the activating sleeve 350 causes elastic or plastic deformation of such a radial locking mechanism. Other locking methods could include collet mechanisms, j-slots, snap-fit, interference fit, or friction alone. The upper split lock ring 382 can be formed from one or more of a variety of materials, including brass, aluminum, steel, composite materials, elastomers, and thermoplastic or thermoset polymers. Material selection for the upper split lock ring 382 can provide predetermined retention of the shoulder 360 of the activating sleeve 350 up to selected force limits, beyond which the upper split lock ring 382 can be elastically or plastically deformed to allow passage of the shoulder 360. Material selection for the upper split lock ring 382 can facilitate drilling of the components at the completion of an operation.

[0030] An upper inner frustoconical surface 384 of the upper lock ring 340 flares radially upwardly and outwardly. For example, the upper surface 384 can face radially inwardly and upwardly (i.e., toward the axial entry bore 312) at any point thereon. A lower surface 386 can extend in a radial plane. For example, the lower surface 386 can face axially toward the axial exit bore 314 at any point thereon. The upper split lock ring 382 can have an inner cross-sectional dimension (e.g., a diameter) that is smaller than an outer cross-sectional dimension (e.g., a diameter) of the shoulder 360 of the activating sleeve 350.

[0031] Before the activating sleeve 350 moves downwardly, the upper split lock ring 382 can prevent the activating sleeve 350 from moving upwardly by engaging the shoulder 360. According to some embodiments, no shear fastener is required to prevent the activating sleeve 350 from moving upwardly. For example, as shown in FIG. 3A, the upper lock ring 382 can be biased to contract radially inwardly such that the lower surface 386 of the upper lock ring 382 can contact and engage the upper face 364 of the shoulder 360. The surface contours of the lower surface 386 and the upper face 364 can be such that an upward force applied by the upper face 364 to the lower surface 386 does not tend to cause radial expansion of the upper lock ring 382.

[0032] According to some embodiments, a lower split lock ring 340 surrounds an exterior surface of the activating sleeve 350, and is contained within an annular recess 334. An upper inner frustoconical surface 342 of the lower lock ring 340 flares radially upwardly and outwardly. For example, the upper surface 342 can face radially inwardly and upwardly (i.e., toward the axial entry bore 312) at any point thereon. By further example, the upper surface 342 can form an oblique angle relative to a longitudinal axis of the valve assembly 300. Such an angle can be selected to determine, at least in part, the force required to shift the activating sleeve 350 past the lower lock ring 340. An angle formed by the upper surface 342 relative to a longitudinal axis can be equal to an angle formed by the lower face 362 relative to the same longitudinal axis. A lower surface 344 can extend in a radial plane. For example, the lower surface 344 can face axially toward the axial exit bore 314 at any point thereon. The lower split lock ring 340 can have an inner cross-sectional dimension (e.g., a diameter) that is smaller than an outer cross-sectional dimension (e.g., a diameter) of the shoulder 360 of the activating sleeve 350.

[0033] When the activating sleeve 350 moves downwardly, the lower face 362 is configured to apply a force against the upper surface 342 of the lower split lock ring 340. The lower split lock ring 340 can be discontinuous or otherwise sufficiently flexible to move radially outwardly into the annular recess 334 and allow passage of the shoulder 360. The lower split lock ring 340 can be formed as a circumferentially discontinuous ring that can expand to increase an opening there through. Other radial locking mechanisms can be used to controllably retain the activating sleeve 350. For example, one or more retractable protrusions, biased radially inwardly, can individually engage corresponding portions of the shoulder 360. By further example, a radial locking mechanism can be provided to retain the activating sleeve 350 until a force by the activating sleeve 350 causes elastic or plastic deformation of such a radial locking mechanism. Other locking methods could include collet mechanisms, j-slots, snap-fit, interference fit, or friction alone. The lower split lock ring 340 can be formed from one or more of a variety of materials, including brass, aluminum, steel, composite materials, and polymers. Material selection for the lower split lock ring 340 can provide predetermined retention of the shoulder 360 of the activating sleeve 350 up to selected force limits, beyond which the lower split lock ring 340 can be elastically or plastically deformed to allow

passage of the shoulder 360. Material selection for the lower split lock ring 340 can facilitate drilling of the components at the completion of an operation. The lower face 362 and the upper surface 342 can provide complementary surface contours to maximize an amount of surface contact between the lower face 362 and the upper surface 342.

[0034] After the activating sleeve 350 moves downwardly, the lower split lock ring 340 can prevent the activating sleeve 350 from moving upwardly again by engaging the shoulder 360. For example, as shown in FIG. 3D, the lower face 362 of the shoulder 360 can settle upon the frustoconical surface 336 of the lower housing 396. The lower face 362 and the frustoconical surface 336 can provide complementary surface contours to maximize an amount of surface contact between the lower face 362 and the frustoconical surface 336. After the activating sleeve 350 complete such downward travel, the lower lock ring 340 can contract radially inwardly such that the lower surface 344 of the lower lock ring 340 can contact and engage the upper face 364 of the shoulder 360. The surface contours of the lower surface 344 and the upper face 364 can be such that an upward force applied by the upper face 364 to the lower surface 344 does not tend to cause radial expansion of the lower lock ring 340.

[0035] With reference to FIGS. 1A-1B and 3A-3D, exemplary operation of the valve assembly 300 is now provided, according to one or more embodiments.

[0036] Differential fill float collar 136, as previously noted, is run into the open wellbore suspended from casing 132. The wellbore is generally filled with fluid such as drilling mud, and the casing is "floated" into the wellbore. The casing bore 142 above the differential fill float collar 136 is filled with wellbore fluid at a gradual rate, so that the casing 132 above float collar 136 is only partially filled and "floated" into the hole, lessening strain on the derrick. The fluid level above float collar 136 will thus be below that outside the casing. The difference in fluid level is a function of the weight of the drilling fluid and the fillup spring size; the fillup spring may be selected to provide the desired fill rate.

[0037] While the casing is being run, the top end of activating sleeve 350 maintains backpressure flapper 320 in an open position. Circulation can be established at any time during the running of the casing without releasing activating sleeve 350.

[0038] Referring to FIGS. 3B-3C, a weighted tripping ball 399 is dropped down the casing bore 142, where it travels downward until it seats on annular lip 356 in activating sleeve 350. The pressure above ball 399 will build until the activating sleeve 350 travels downward, releasing backpressure flapper 5 320. According to some embodiments, the only force required to allow travel of the activating sleeve 350 is the force required to actuate the lower lock ring 340. According to some embodiments, the activating sleeve 350 is not secured to the lower housing 396 or any portion of the valve assembly 300. Rather, the only limits on axial movement of the activating sleeve 350 are imposed by the upper 10 lock ring 382 and a lower lock ring 340.

[0039] As shown in FIG. 3D, after the activating sleeve 350 reaches the full extent of its travel, ball 399 can be extended past the annular lip 356 and be pumped out of the float collar 136 to the bottom of the wellbore. Ports 380 in the wall of activating sleeve 350 permit any fluid trapped near the annular 15 shoulder 360 of the activating sleeve 350 to escape when the activating sleeve 350 moves down. The activating sleeve 350 is prevented from moving back to its original position by the lock ring 340. As the shoulder 360 on activating sleeve 350 contacts the frustoconical upper face 342 on the lock ring 340, the lock ring 340 is forced apart and over the shoulder 360. When differential 20 pressure is released (as when ball 399 leaves the float collar 136), the lower face 344 of the lock ring 340 will engage corresponding portions of the shoulder 360 of the activating sleeve 350.

[0040] As the cementing operation is performed, the released backpressure flapper 320 is able to control any back flow of cement up into 25 casing bore 142, as the elastomeric seal 326 seats on the annular surface 316 of the upper housing 310 as the hydrostatic pressure in the casing bore 144 and the force of the spring 322 urges the backpressure flapper 320 into a closed position. At the resumption of cement pumping, pump pressure in the casing bore 142 overcomes the spring force and hydrostatic pressure below the float 30 collar 136, and the backpressure flapper 320 reopens.

[0041] After the cementing operation is completed, the interior components of the float collar 136 can be drilled out by means known in the art to provide an open casing bore to the bottom of the casing.

[0042] Embodiments disclosed herein include:

[0043] A. A valve assembly, including: a flapper valve biased to move from a restrained position to a released position to cover an entry bore; an activating sleeve retaining the flapper valve in the restrained position and having a shoulder; an upper radial lock mechanism configured to prevent movement of the shoulder toward the entry bore and past the upper radial lock mechanism; a lower radial lock mechanism between the shoulder and an exit bore, the lower radial lock mechanism configured to prevent movement of the shoulder toward the exit bore and past the lower radial lock mechanism until a force threshold is exceeded.

[0044] B. A tool string, including: a casing; a float collar within the casing; a valve assembly within the float collar, the valve assembly including: a flapper valve biased to move from a restrained position to a released position to cover an entry bore; an activating sleeve retaining the flapper valve in the restrained position and having a shoulder; an upper radial lock mechanism configured to prevent movement of the shoulder toward the entry bore and past the upper radial lock mechanism; a lower radial lock mechanism between the shoulder and an exit bore, the lower radial lock mechanism configured to prevent movement of the shoulder toward the exit bore and past the lower radial lock mechanism until a force threshold is exceeded.

[0045] C. A method, including: providing a valve assembly with (i) an activating sleeve retaining a flapper valve in a restrained position and (ii) an upper radial lock mechanism preventing movement of a shoulder of the activating sleeve toward an entry bore of the valve assembly and past the upper radial lock mechanism; advancing the activating sleeve toward an exit bore by delivering a tripping ball to the activating sleeve; and releasing the flapper valve to move from a restrained position to a released position to cover the entry bore.

[0046] Each of embodiments A, B, and C may have one or more of the following additional elements in any combination:

[0047] Element 1: when the shoulder is between the lower radial lock mechanism and the exit bore, the lower radial lock mechanism can be configured to prevent movement of the shoulder toward the entry bore and past the lower radial lock mechanism. Element 2: the upper radial lock mechanism can be between the shoulder and the entry bore. Element 3: the upper radial lock mechanism can have an inner cross-sectional dimension that is smaller than an

outer cross-sectional dimension of the shoulder. Element 4: the lower radial lock mechanism can have an inner cross-sectional dimension that is smaller than an outer cross-sectional dimension of the shoulder. Element 5: the flapper valve, in the released position, can allow fluid flow from the entry bore to the exit bore and prevents fluid flow from the exit bore to the entry bore. Element 6: the activating sleeve can provide an annular lip having an inner cross-sectional dimension that is smaller than an outer cross-sectional dimension of a tripping ball size to travel through the entry bore to the activating sleeve. Element 7: a lower radial lock mechanism between the shoulder and the exit bore can be configured to prevent the advancing until a force threshold is exceeded. Element 8: the advancing can include moving the shoulder toward the exit bore and past a lower radial lock mechanism. Element 9: fluid flow can be allowed from the entry bore to the exit bore through the flapper valve, in the released position, and preventing fluid flow from the exit bore to the entry bore. Element 10: advancing the activating sleeve can include seating a tripping ball on an annular lip of the activating sleeve and creating a pressure differential across the activating sleeve. Element 11: the tripping ball can be advanced through the annular lip.

[0048] Therefore, the disclosed systems and methods are well adapted to attain the ends and advantages mentioned as well as those that are inherent therein. The particular embodiments disclosed above are illustrative only, as the teachings of the present disclosure may be modified and practiced in different but equivalent manners apparent to those skilled in the art having the benefit of the teachings herein. Furthermore, no limitations are intended to the details of construction or design herein shown, other than as described in the claims below. It is therefore evident that the particular illustrative embodiments disclosed above may be altered, combined, or modified and all such variations are considered within the scope of the present disclosure. The systems and methods illustratively disclosed herein may suitably be practiced in the absence of any element that is not specifically disclosed herein and/or any optional element disclosed herein. While compositions and methods are described in terms of "comprising," "containing," or "including" various components or steps, the compositions and methods can also "consist essentially of" or "consist of" the various components and steps. All numbers and ranges disclosed above may vary by some amount. Whenever a numerical range with a lower limit and an

upper limit is disclosed, any number and any included range falling within the range is specifically disclosed. In particular, every range of values (of the form, "from about a to about b," or, equivalently, "from approximately a to b," or, equivalently, "from approximately a-b") disclosed herein is to be understood to set forth every number and range encompassed within the broader range of values. Also, the terms in the claims have their plain, ordinary meaning unless otherwise explicitly and clearly defined by the patentee. Moreover, the indefinite articles "a" or "an," as used in the claims, are defined herein to mean one or more than one of the element that it introduces. If there is any conflict in the usages of a word or term in this specification and one or more patent or other documents that may be incorporated herein by reference, the definitions that are consistent with this specification should be adopted.

[0049] As used herein, the phrase "at least one of" preceding a series of items, with the terms "and" or "or" to separate any of the items, modifies the list as a whole, rather than each member of the list (*i.e.*, each item). The phrase "at least one of" allows a meaning that includes at least one of any one of the items, and/or at least one of any combination of the items, and/or at least one of each of the items. By way of example, the phrases "at least one of A, B, and C" or "at least one of A, B, or C" each refer to only A, only B, or only C; any combination of A, B, and C; and/or at least one of each of A, B, and C.

[0050] The use of directional terms such as above, below, upper, lower, upward, downward, left, right, uphole, downhole and the like are used in relation to the illustrative embodiments as they are depicted in the figures, the upward direction being toward the top of the corresponding figure and the downward direction being toward the bottom of the corresponding figure, the uphole direction being toward the surface of the well and the downhole direction being toward the toe of the well.

CLAIMS

What is claimed is:

1. A valve assembly, comprising:
 - a flapper valve biased to move from a restrained position to a released position to cover an entry bore;
 - an activating sleeve retaining the flapper valve in the restrained position and having a shoulder;
 - an upper radial lock mechanism that prevents movement of the shoulder toward the entry bore and past the upper radial lock mechanism;
 - a lower radial lock mechanism positioned axially between the shoulder and an exit bore, the lower radial lock mechanism preventing movement of the shoulder toward the exit bore and past the lower radial lock mechanism until a force threshold is exceeded.
2. The valve assembly of claim 1, wherein, when the shoulder is axially positioned between the lower radial lock mechanism and the exit bore, the lower radial lock mechanism prevents movement of the shoulder toward the entry bore.
3. The valve assembly of claim 1, wherein the upper radial lock mechanism is positioned axially between the shoulder and the entry bore.
4. The valve assembly of claim 1, wherein the upper radial lock mechanism has an inner cross-sectional dimension that is smaller than an outer cross-sectional dimension of the shoulder.
5. The valve assembly of claim 1, wherein the lower radial lock mechanism has an inner cross-sectional dimension that is smaller than an outer cross-sectional dimension of the shoulder.
6. The valve assembly of claim 1, wherein the flapper valve, in the released position, allows fluid flow from the entry bore to the exit bore and prevents fluid flow from the exit bore to the entry bore.
7. The valve assembly of claim 1, further comprising an annular lip defined within the activating sleeve and having an inner cross-sectional dimension that is smaller than an outer cross-sectional dimension of a tripping ball sized to travel through the entry bore to the activating sleeve.
8. A tool string, comprising:
 - a casing;
 - a float collar within the casing;

a valve assembly within the float collar, the valve assembly comprising:

- a flapper valve biased to move from a restrained position to a released position to cover an entry bore;
- an activating sleeve retaining the flapper valve in the restrained position and having a shoulder;
- an upper radial lock mechanism that prevents movement of the shoulder toward the entry bore and past the upper radial lock mechanism;
- a lower radial lock mechanism positioned axially between the shoulder and an exit bore, the lower radial lock mechanism preventing movement of the shoulder toward the exit bore and past the lower radial lock mechanism until a force threshold is exceeded.

9. The tool string of claim 8, wherein, when the shoulder is axially positioned between the lower radial lock mechanism and the exit bore, the lower radial lock mechanism prevents movement of the shoulder toward the entry bore and past the lower radial lock mechanism.

10. The tool string of claim 8, wherein the upper radial lock mechanism is positioned axially between the shoulder and the entry bore.

11. The tool string of claim 8, wherein the upper radial lock mechanism is an expandable lock ring having an inner cross-sectional dimension that is smaller than an outer cross-sectional dimension of the shoulder.

12. The tool string of claim 8, wherein the lower radial lock mechanism is an expandable lock ring having an inner cross-sectional dimension that is smaller than an outer cross-sectional dimension of the shoulder.

13. The tool string of claim 8, wherein the flapper valve, in the released position, allows fluid flow from the entry bore to the exit bore and prevents fluid flow from the exit bore to the entry bore.

14. The tool string of claim 8, further comprising an annular lip defined within the activating sleeve and having an inner cross-sectional dimension that is smaller than an outer cross-sectional dimension of a tripping ball sized to travel through the entry bore to the activating sleeve.

15. A method, comprising:

providing a valve assembly with an activating sleeve that retains a flapper valve in a restrained position and an upper radial lock mechanism

that prevents movement of a shoulder of the activating sleeve toward an entry bore of the valve assembly and past the upper radial lock mechanism;

advancing the activating sleeve toward an exit bore by locating a tripping ball on the activating sleeve; and

releasing the flapper valve to move from a restrained position to a released position to cover the entry bore.

16. The method of claim 15, further comprising preventing the activating sleeve from advancing toward the exit bore with a lower radial lock mechanism positioned axially between the shoulder and the exit bore is configured to prevent the advancing until a force threshold is exceeded.

17. The method of claim 16, wherein advancing the activating sleeve toward the exit bore comprises exceeding a force threshold of the lower radial lock mechanism and thereby moving the shoulder past the lower radial lock mechanism.

18. The method of claim 15, further comprising:

allowing fluid flow from the entry bore to the exit bore through the flapper valve with the flapper valve in the released position; and

preventing fluid flow from the exit bore to the entry bore with the flapper valve in the released position.

19. The method of claim 15, wherein advancing the activating sleeve comprises:

seating the tripping ball on an annular lip defined on an inner surface of the activating sleeve; and

creating a pressure differential across the activating sleeve.

20. The method of claim 19, further comprising advancing the tripping ball through the annular lip.

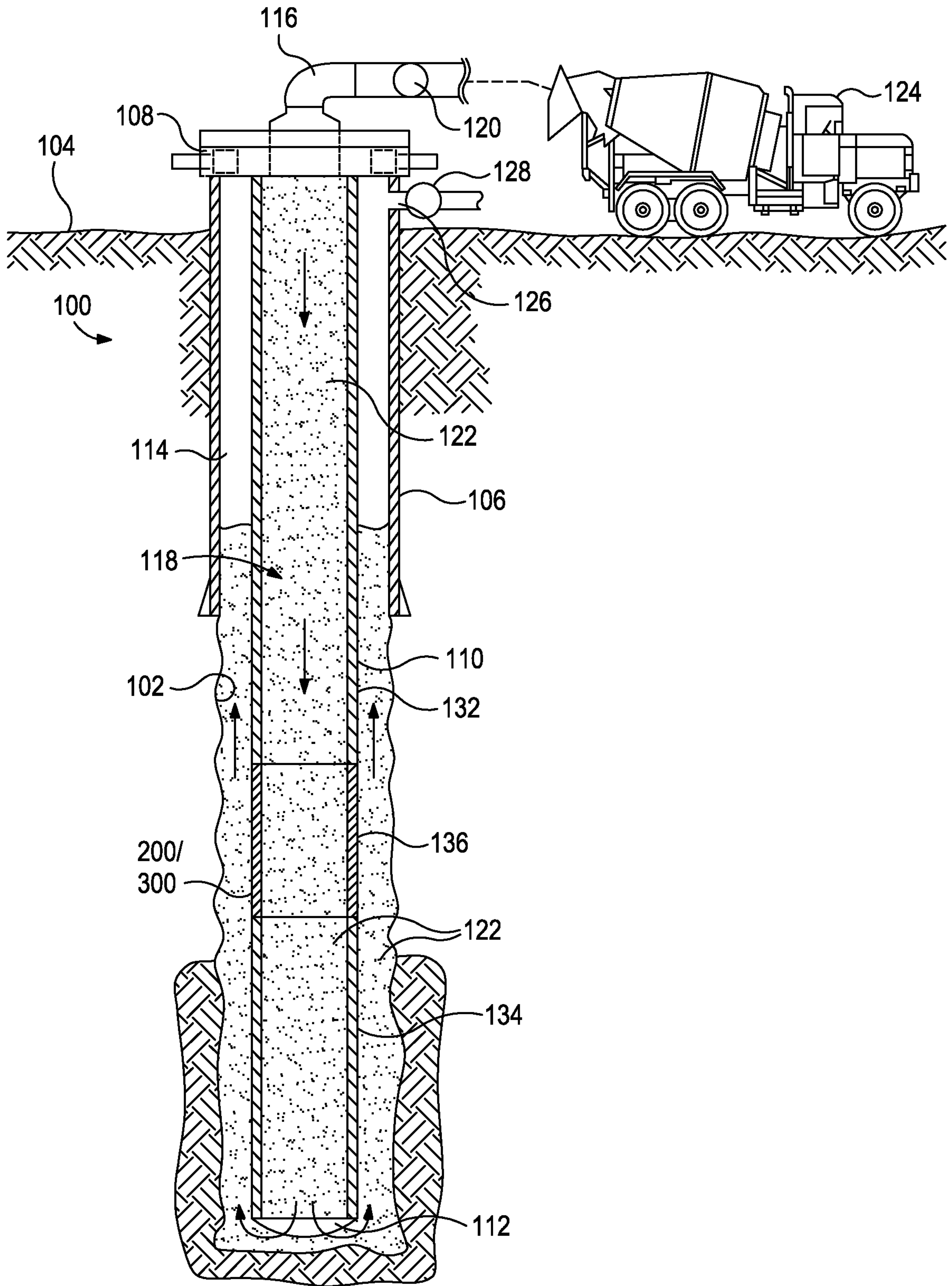

FIG. 1A

L

2/7

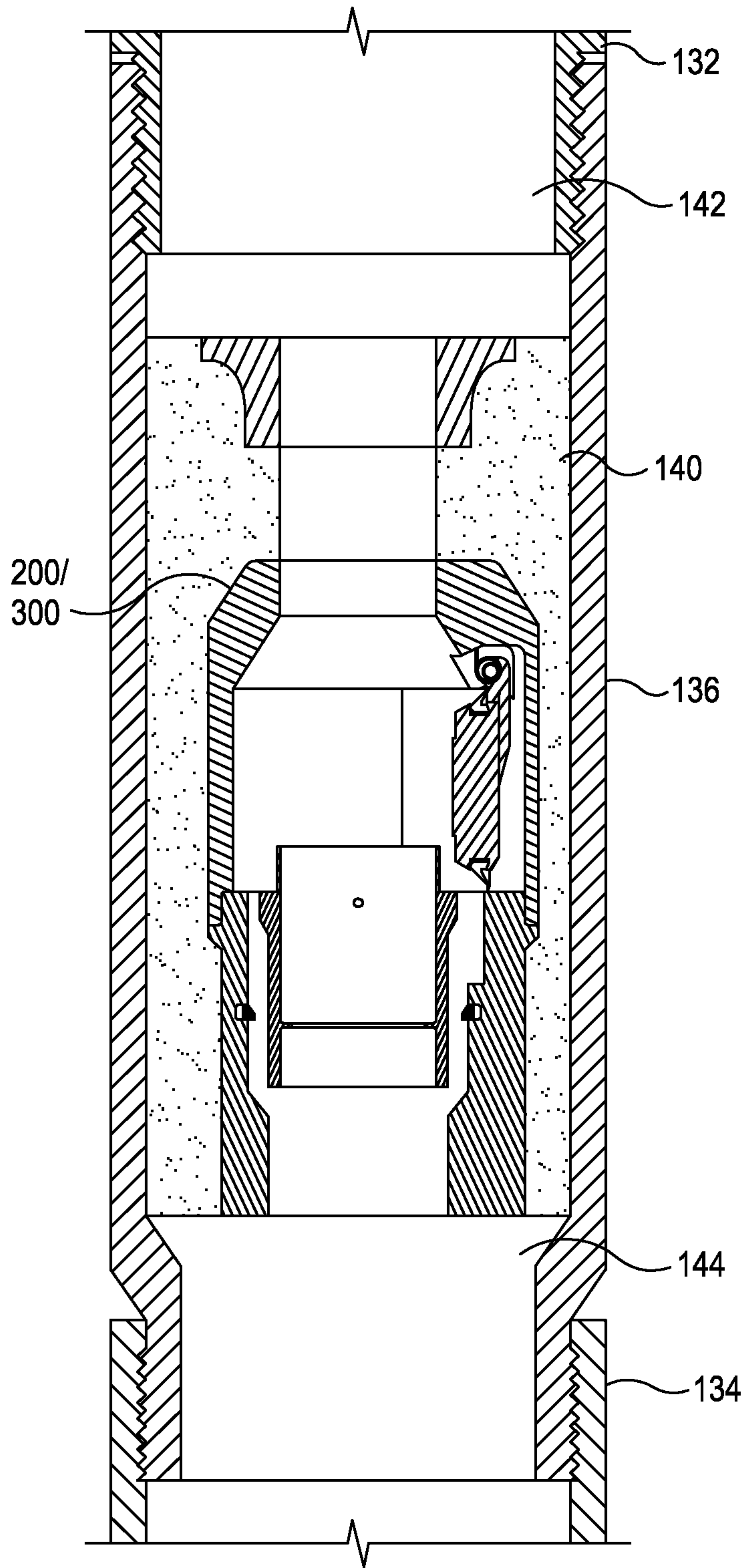

FIG. 1B

L

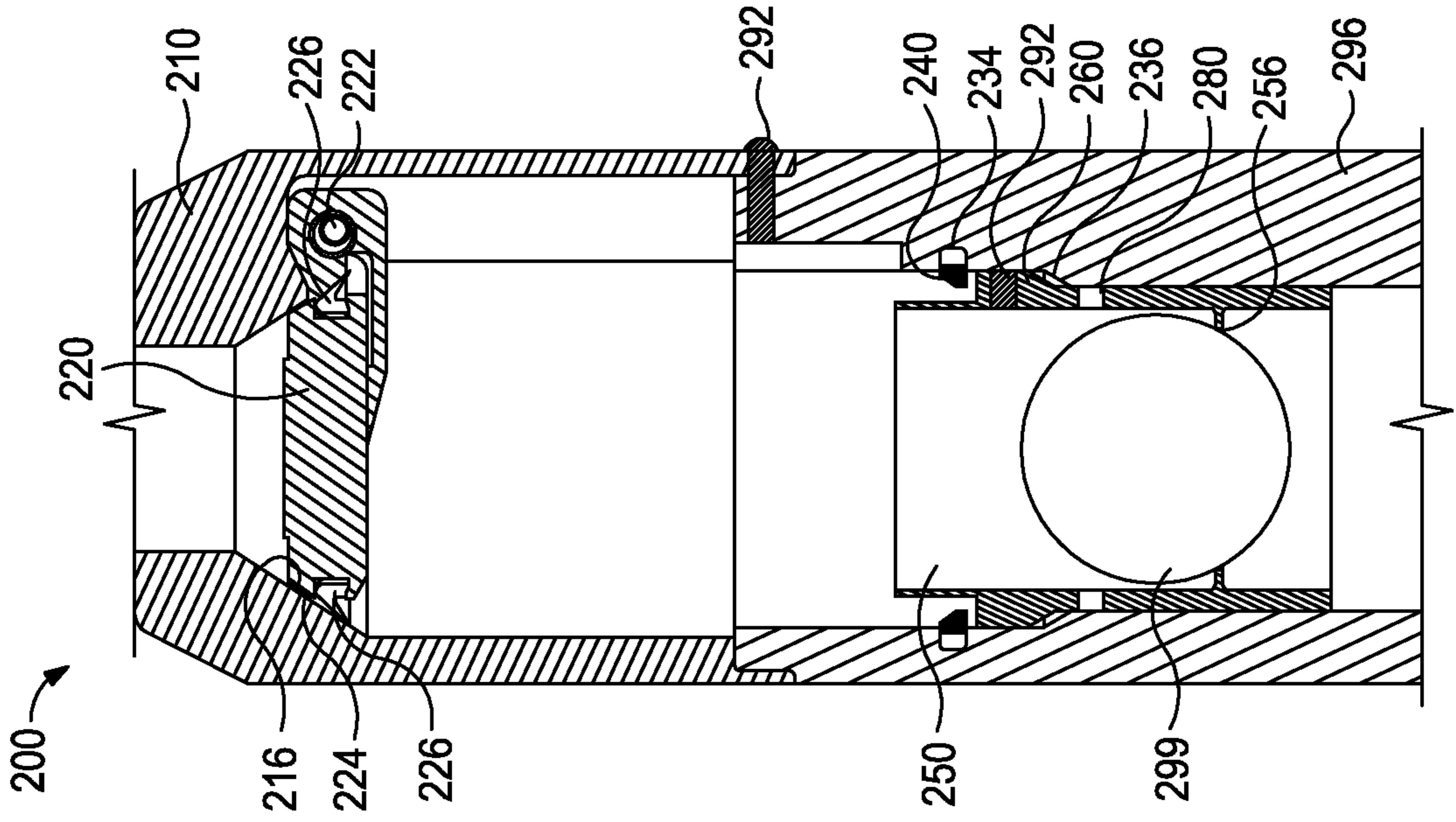

FIG. 2A

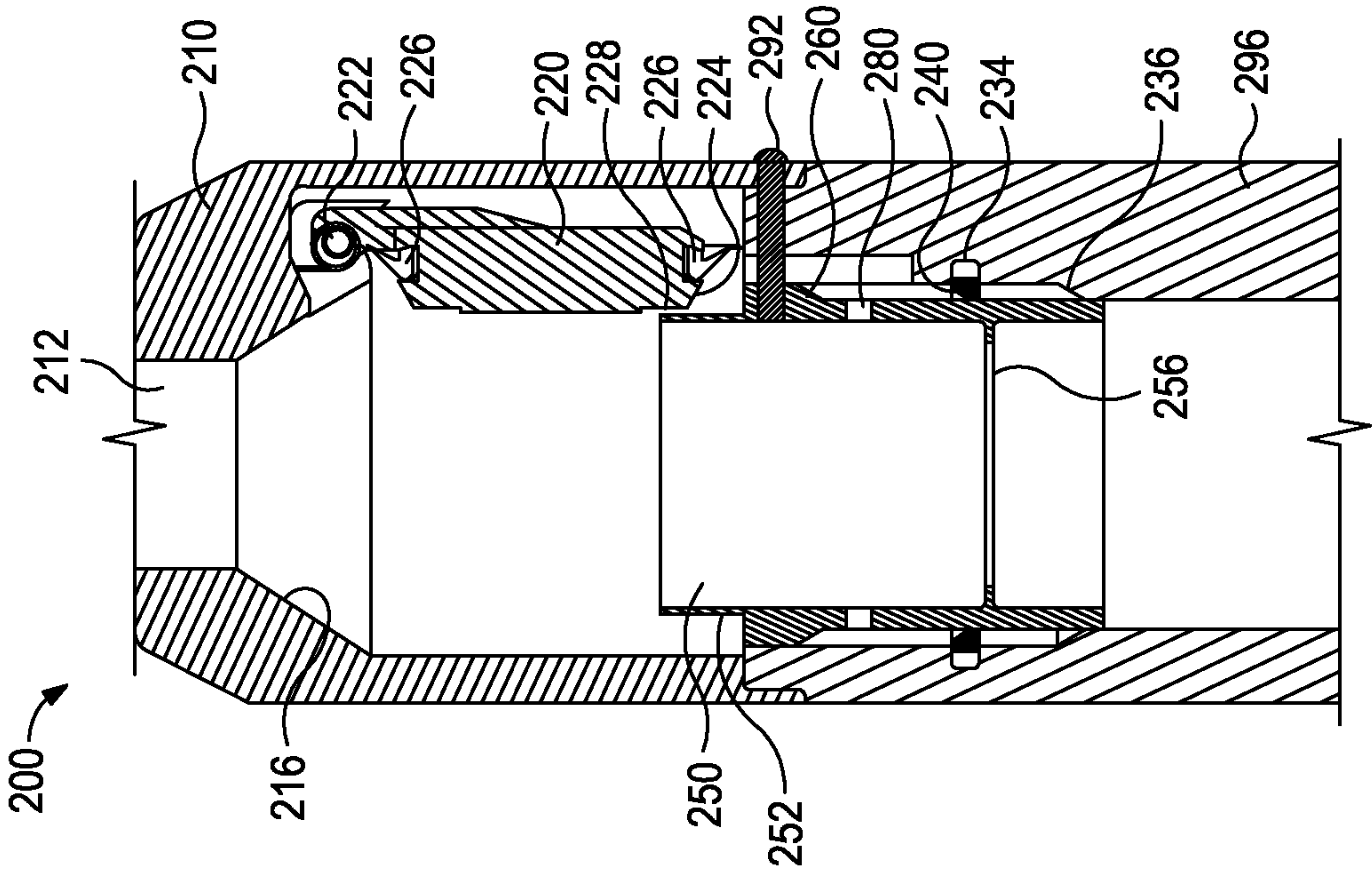

FIG. 2B

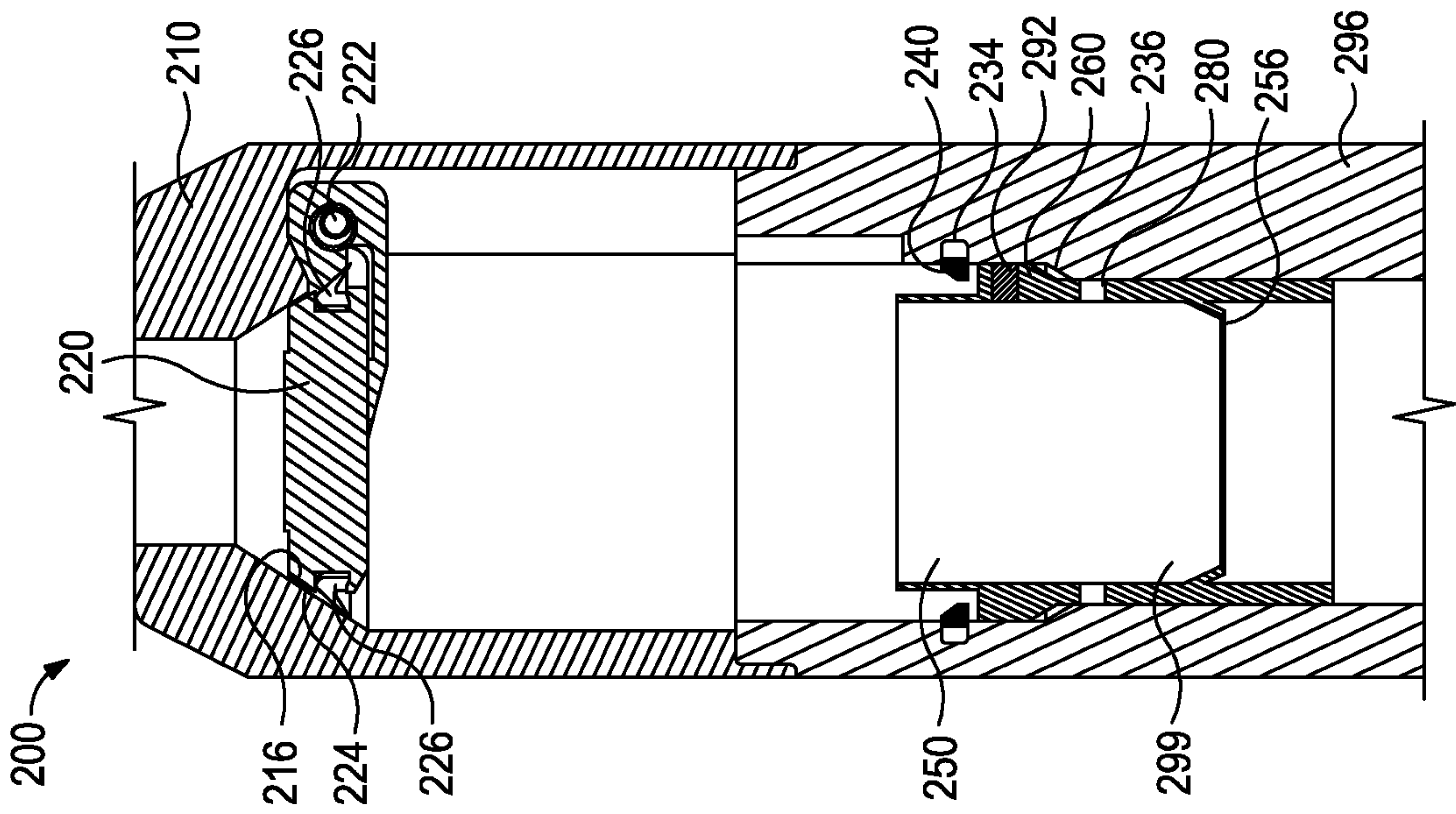
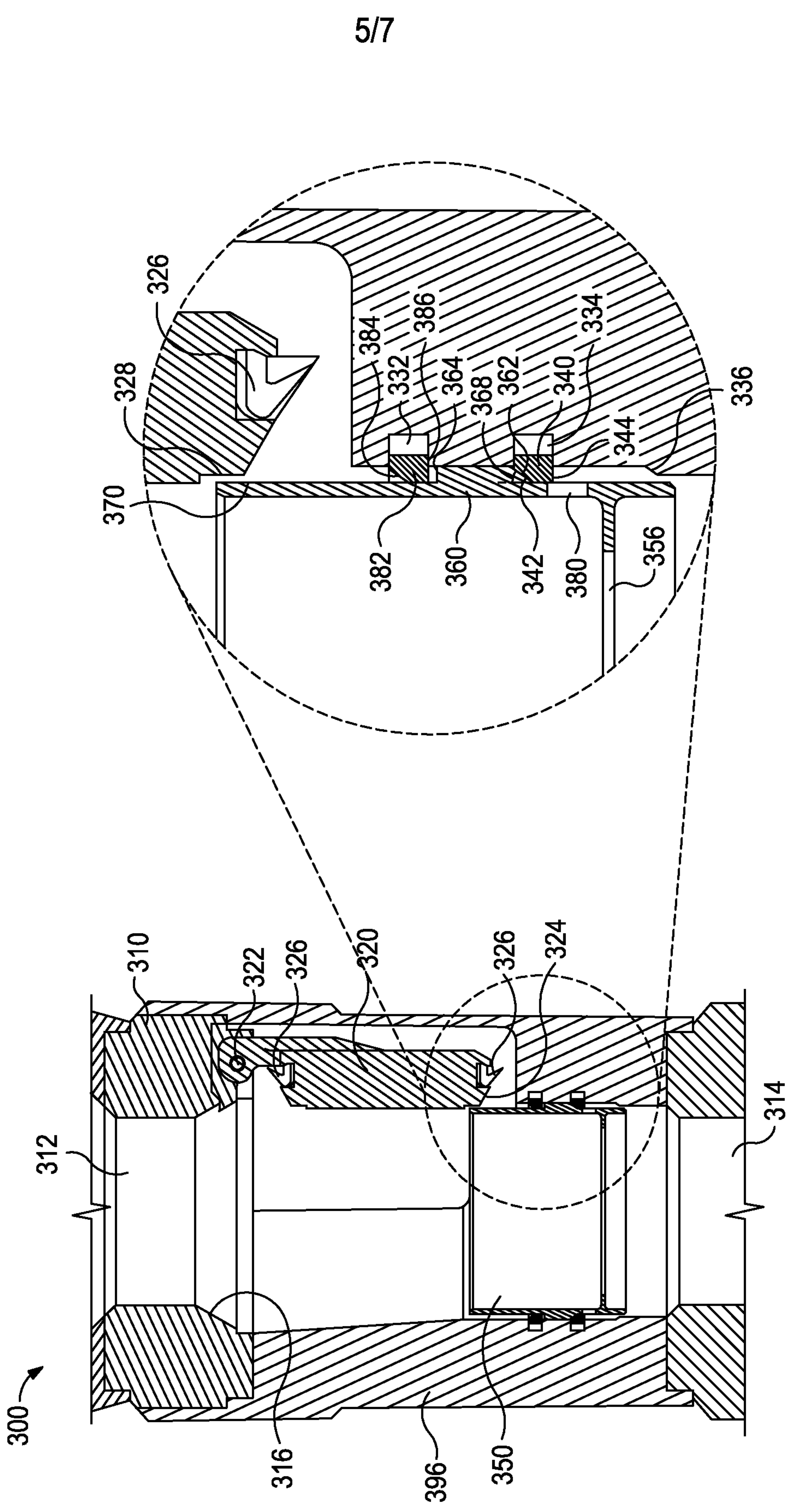

FIG. 2C



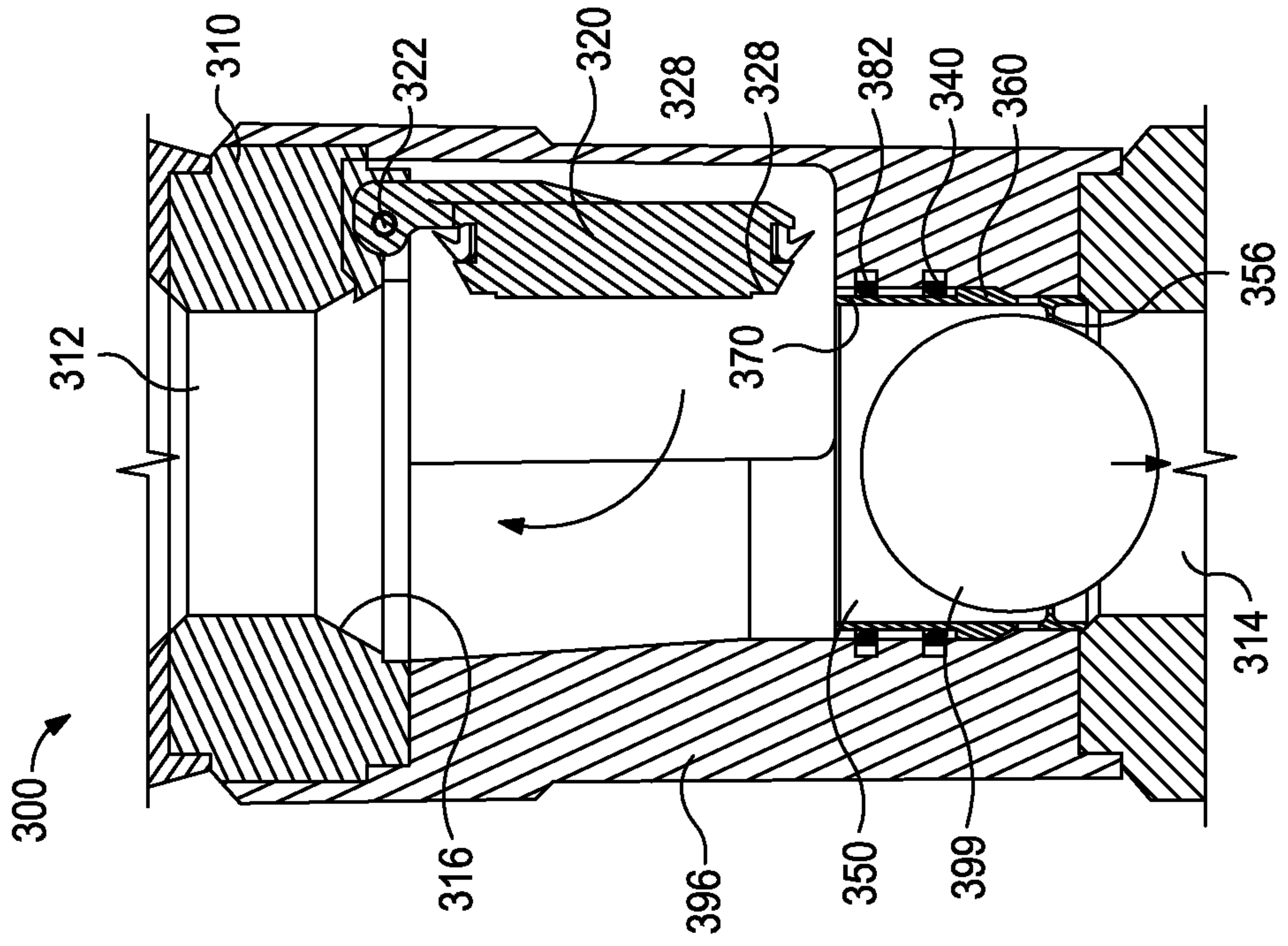

FIG. 3C

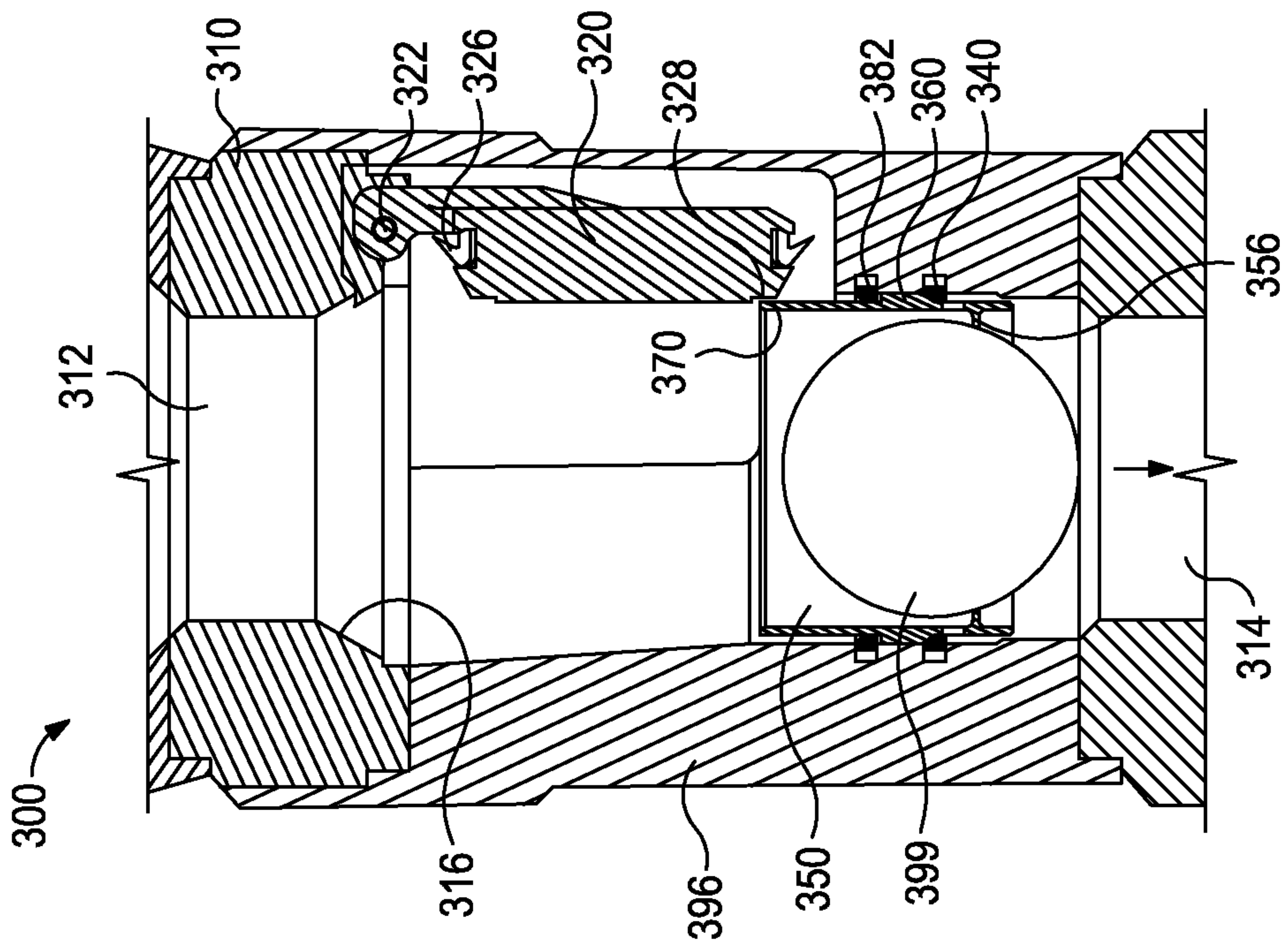

FIG. 3B

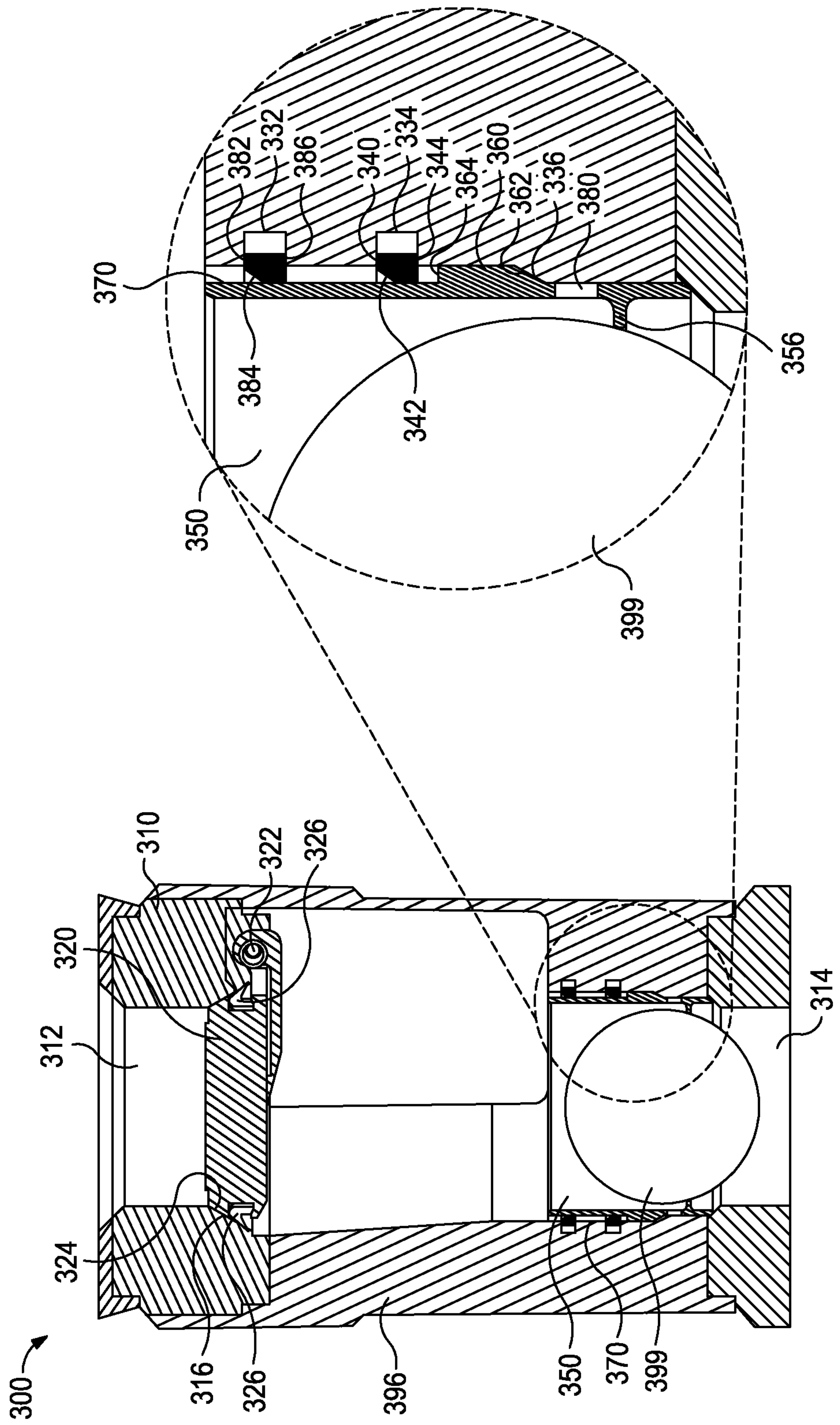

FIG. 3D

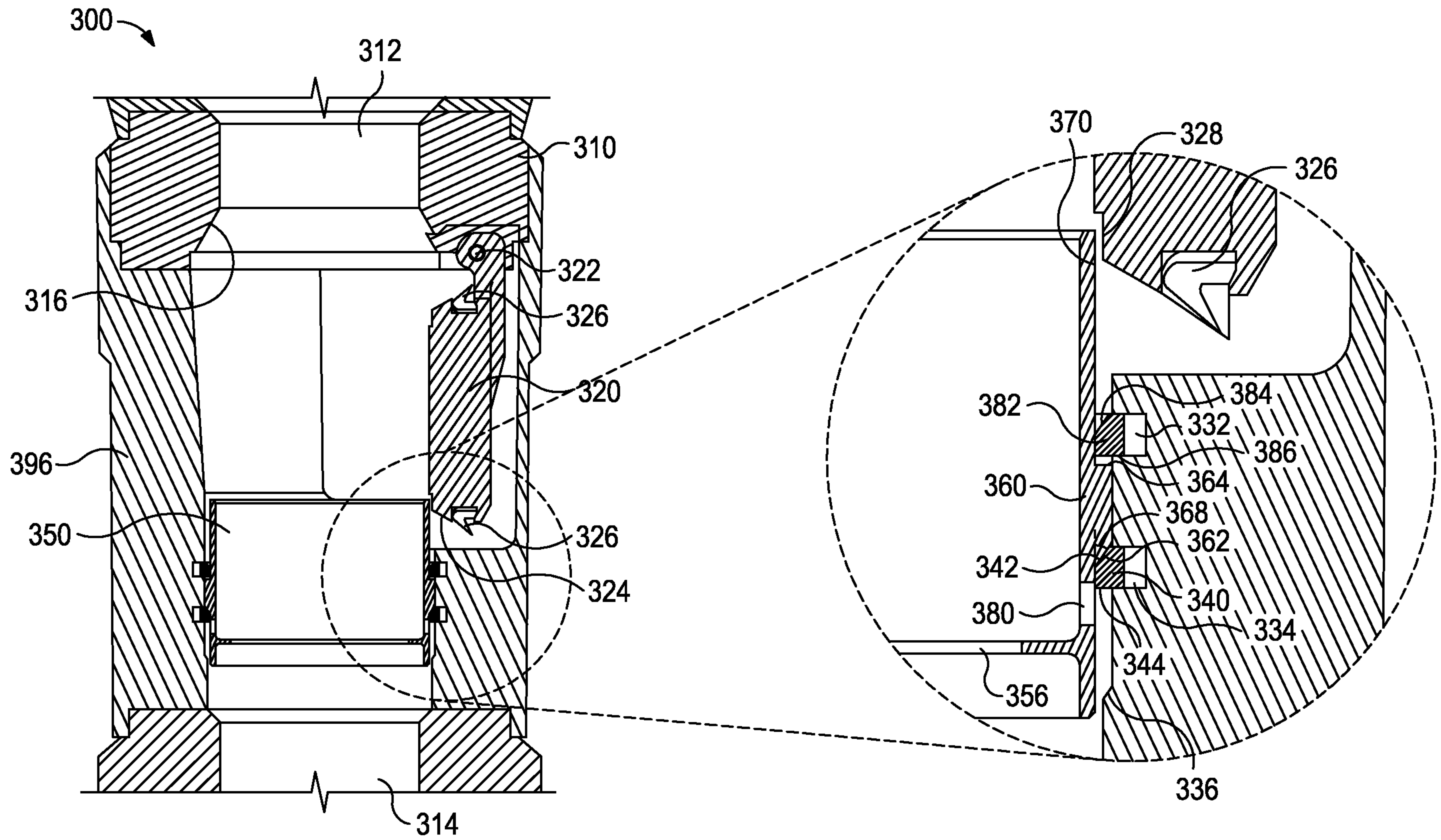

FIG. 3A