

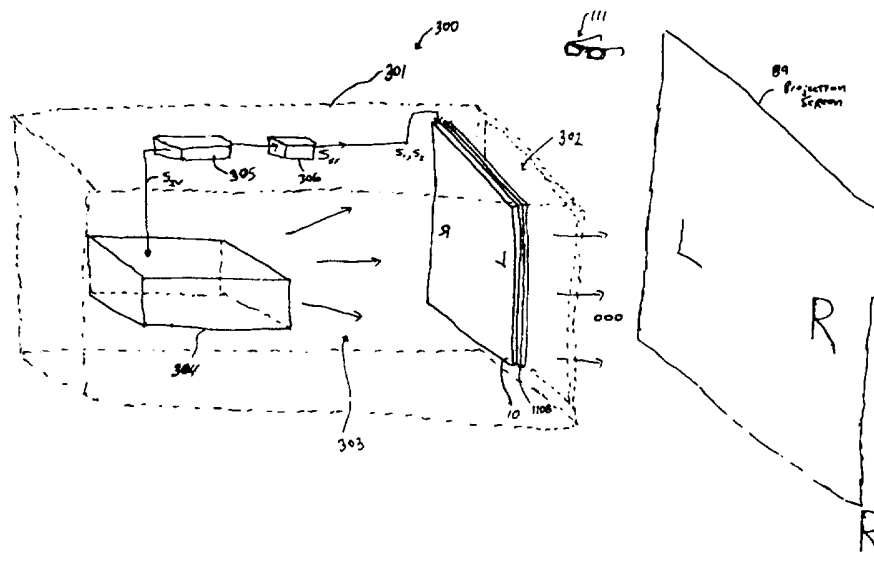

INTERNATIONAL APPLICATION PUBLISHED UNDER THE PATENT COOPERATION TREATY (PCT)

<p>(51) International Patent Classification ⁶ : G02F 1/13, 1/1335, 1/1347, G02B 21 /56, 21 /132</p>	A1	<p>(11) International Publication Number: WO 97/20250</p> <p>(43) International Publication Date: 5 June 1997 (05.06.97)</p>
<p>(21) International Application Number: PCT/US96/19718</p> <p>(22) International Filing Date: 29 November 1996 (29.11.96)</p> <p>(30) Priority Data: 08/563,520 28 November 1995 (28.11.95) US</p> <p>(71) Applicant (for all designated States except US): REVEO, INC. [US/US]; 8 Skyline Drive, Hawthorne, NY 10532 (US).</p> <p>(72) Inventors; and (75) Inventors/Applicants (for US only): FARIS, Sadeg, M. [US/US]; 24 Pocantico River Road, Pleasantville, NY 10570 (US). LI, Le [CN/CN]; 3491 Overlook Avenue, Yorktown Heights, NY 10598 (US).</p> <p>(74) Agent: PERKOWSKI, Thomas, J.; 10 Waldon Road, Darien, CT 06820 (US).</p>		<p>(81) Designated States: AL, AM, AT, AU, AZ, BB, BG, BR, BY, CA, CH, CN, CZ, DE, DK, EE, ES, FI, GB, GE, HU, IS, JP, KE, KG, KP, KR, KZ, LK, LR, LS, LT, LU, LV, MD, MG, MK, MN, MW, MX, NO, NZ, PL, PT, RO, RU, SD, SE, SG, SI, SK, TJ, TM, TR, TT, UA, UG, US, UZ, VN, ARIPO patent (KE, LS, MW, SD, SZ, UG), Eurasian patent (AM, AZ, BY, KG, KZ, MD, RU, TJ, TM), European patent (AT, BE, CH, DE, DK, ES, FI, FR, GB, GR, IE, IT, LU, MC, NL, PT, SE), OAPI patent (BF, BJ, CF, CG, CI, CM, GA, GN, ML, MR, NE, SN, TD, TG).</p> <p>Published With international search report. Before the expiration of the time limit for amending the claims and to be republished in the event of the receipt of amendments.</p>

(54) Title: IMAGE DISPLAY SYSTEMS HAVING DIRECT AND PROJECTION VIEWING MODES



(57) Abstract

A transportable image display system (300) has direct and projection viewing modes of operation. The system (300) comprises a transportable housing (301) having a light transmission aperture (302) and an interior volume (303) within which the electro-optical panel assembly (10), the micropolarization panel (110B), the light projection system (304), the system controller (305) and the image inverter (306) are configured to carry out the direct and projection viewing modes of operation. During the direct viewing mode, light from the light projection system (304) is scattered and modulated by the electro-optical panel (10) to form a first image for direct viewing. During the projection viewing mode, light from the light projection system (304) is modulated without substantial scattering by the electro-optical panel (10) to form a second image for projection onto a projection screen (89).

FOR THE PURPOSES OF INFORMATION ONLY

Codes used to identify States party to the PCT on the front pages of pamphlets publishing international applications under the PCT.

AM	Armenia	GB	United Kingdom	MW	Malawi
AT	Austria	GE	Georgia	MX	Mexico
AU	Australia	GN	Guinea	NE	Niger
BB	Barbados	GR	Greece	NL	Netherlands
BE	Belgium	HU	Hungary	NO	Norway
BF	Burkina Faso	IE	Ireland	NZ	New Zealand
BG	Bulgaria	IT	Italy	PL	Poland
BJ	Benin	JP	Japan	PT	Portugal
BR	Brazil	KE	Kenya	RO	Romania
BY	Belarus	KG	Kyrgyzstan	RU	Russian Federation
CA	Canada	KP	Democratic People's Republic of Korea	SD	Sudan
CF	Central African Republic	KR	Republic of Korea	SE	Sweden
CG	Congo	KZ	Kazakhstan	SG	Singapore
CH	Switzerland	LI	Liechtenstein	SI	Slovenia
CI	Côte d'Ivoire	LK	Sri Lanka	SK	Slovakia
CM	Cameroon	LR	Liberia	SN	Senegal
CN	China	LT	Lithuania	SZ	Swaziland
CS	Czechoslovakia	LU	Luxembourg	TD	Chad
CZ	Czech Republic	LV	Latvia	TG	Togo
DE	Germany	MC	Monaco	TJ	Tajikistan
DK	Denmark	MD	Republic of Moldova	TT	Trinidad and Tobago
EE	Estonia	MG	Madagascar	UA	Ukraine
ES	Spain	ML	Mali	UG	Uganda
FI	Finland	MN	Mongolia	US	United States of America
FR	France	MR	Mauritania	UZ	Uzbekistan
GA	Gabon			VN	Viet Nam

IMAGE DISPLAY SYSTEMS HAVING
DIRECT AND PROJECTION VIEWING MODES

5

BACKGROUND OF INVENTION

Technical Field

The present invention relates to transportable systems having both direct and projection viewing modes of operation, and to electro-optical backlighting panels for use therein.

Background Art

Presently, most portable computing systems include a flat liquid crystal display (LCD) panel for directly viewing video imagery displayed thereon. Portable computer systems of this type include notebook, laptop, and palmtop computers.

In general, prior art LCD display panels have essentially the same basic construction in that each includes a conventional backlighting structure affixed to the rear surface of either a passive or active matrix LCD panel. Several different backlighting panel designs are described in the technical paper "New Backlighting Technologies for LCDs" by Kevin J. Hathaway, et al., published at pages 751-754 in SID 91 Digest. In recent times, the "light pipe" backlight design, in particular, has been widely used in many commercially available notebook computers.

Specifically, prior art "light pipe" backlight assemblies are constructed from a rectangularly shaped light guiding panel, typically fabricated from an acrylic plastic sheet having a thickness of about 4 millimeters or so. Along the opposite side edges of the acrylic sheet, a pair of miniature fluorescent light tubes are mounted within suitably designed light reflective mounts. The function of the fluorescent light

tubes is to produce and direct incoherent light into the interior of the light guiding panel within which the light is typically bounded by the well known principle of "total internal reflection". Under ideal conditions, light will not leak out of the surfaces of the acrylic plastic sheet. However, light can be extracted or leaked out from these surfaces by forming therein scratches, undulations, or any other means of locally altering the critical angle for total internal reflection. By achieving light extraction in this manner, the backlighting panel can be used to illuminate an LCD panel.

10 In order to compensate for the decrease in light intensity in the light guiding panel at distances away from the fluorescent tubes, a light extracting pattern is permanently formed on one or both surfaces of the light guiding panel. Typically the light extracting pattern is realized as a dot pattern permanently embossed or sand-blasted upon the front surface of the acrylic light guiding panel. The density of the dot pattern is made to increase quadratically with distance from the fluorescent light tubes in order to achieve light intensity compensation along the light guiding panel. With this construction, a constant backlighting brightness is maintained across the light guiding panel.

20 In order to integrate (i.e. diffuse) the spotted distribution of light emanating from the light extracting pattern towards the LCD panel, a first light diffusing structure is placed on top of the light guiding panel. Typically, the first light diffusing structure is made from one or more thin sheets of translucent plastic attached to the front surface of the light guiding panel. In most commercial "light pipe" backlight designs, a second light diffusing structure is placed over the rear surface of the light guiding panel to diffuse the spotted distribution of light emanating from the permanently formed light extracting pattern towards the

reflective surface disposed behind the light guiding panel. Typically, the second light diffusing structure is made from one or more thin sheets of translucent plastic attached to the rear surface of the light guiding panel. Together, the light guiding panel, fluorescent light tubes, light diffusing sheets and the light reflective layer cooperate to produce a plane of backlight having a uniform spatial intensity for optical processing by the LCD panel affixed to the backlighting panel.

While the prior art backlighting panel design described above has proven useful in the direct viewing of visual imagery on LCD display screens, its permanently formed light extracting pattern renders it unsuitable in projection viewing modes of operation. This fact is best illustrated by example.

In the recently introduced notebook computer, marketed under the tradename "Cruiser™" by EMCO/REVERED Technologies, Inc. and generally described in U.S. Patent No. 5,353,075 to Conner, et al., the above-described "light pipe" backlighting panel design is used to construct a portable computer system having both direct and projection viewing modes of operation. In the direct viewing mode, the prior art backlighting panel is positioned against the active-matrix LCD panel. Each time the user desires to operate the notebook computer in its projection viewing mode, the user must mechanically reconfigure the Cruiser™ notebook computer by physically removing the prior art backlighting panel in order to reveal the active matrix LCD panel, and provide an optically clear path for the light rays to pass therethrough.

Recently, Intellimedia, Corporation of Benton Harbor, Michigan has introduced the IntelliMedia™ Multimedia Presentation System which consists of portable computer system having a flat LCD projection panel which can support both direct and projection viewing modes. In

the direct viewing mode, the user of this system is required to affix an auxiliary backlighting panel beneath the LCD panel. Then, when operated in the projection viewing mode, the user is required to remove the auxiliary backlighting panel, and place the LCD panel upon an external overhead projector, much like that required by the Cruiser™ computer system.

While the above-described image display systems provide both direct and projection viewing modes, they both nevertheless suffer from a number of serious shortcomings and drawbacks which make them less than commercially attractive products.

In particular, the need to physically remove the entire backlighting panel from the Cruiser™ computer during its projection viewing mode, poses a substantial risk of damage to the backlighting panel and imposes an added responsibility upon the user to safely store the same when the computer system is operated in its projection viewing mode. Also, from a practical standpoint, the need to place the display panel assembly of the Cruiser™ computer and the entire display panel of the Intellimedia™ system upon an overhead projector during projection viewing, necessitates that the user either tote an overhead projector along with such prior art systems, or have access to one during projection viewing. Consequently, such prior art image display systems lack the versatility of operation in either direct or projection modes of viewing, and thus are incapable of functioning as truly portable systems.

Thus, there is a great need in the art for an improved image display system which has direct and projection viewing modes, without the shortcomings and drawbacks of the prior art systems.

DISCLOSURE OF THE INVENTION

Accordingly, a primary object of the present invention is to
5 provide a novel electro-optical light panel construction particularly
designed for use in image display systems having both direct and
projection viewing modes of operation.

A further object of the present invention is to provide a portable
image display system having direct and projection viewing modes.

10 A further object of the present invention is to provide an image
display system in the form of a portable computer-based system which
can be easily configured into its projection viewing mode using an
electro-optical light panel having light scattering and non-scattering
states of operation selectable under electronic control.

15 A further object of the present invention is to provide a portable
device for illuminating the electro-optical display panel of a computer-
based image display system having direct and projection viewing
modes, in order to project focused video images therefrom onto a
desired viewing surface.

20 A further object of the present invention is to provide a portable
computer-based image display system with a rear housing panel that is
hingedly connected to a light guiding panel and supports a light
reflective surface and covers the rear light transmission aperture when
the system is operated in its direct viewing mode.

25 A further object of the present invention is to provide such a
portable computer-based image display system, in which the display
panel assembly thereof includes a thin light focusing panel, such a
Fresnel or holographic lens panel, for use during the projection viewing

mode.

A further object of the present invention is to provide such a portable computer-based image display system, in which a film slide or optical transparency carrying imagery can be placed upon the display surface of the display panel assembly thereof and the imagery viewed in either the direct or projection viewing mode.

A further object of the present invention is to provide a flat electro-optical display panel assembly having direct and projection viewing modes of operation, and an electro-optical light panel having a light emission state in which light is emitted from the electro-optical panel during the direct viewing mode of operation, and a light transmission state in which externally generated light is permitted to pass through the electro-optical panel without substantial scattering during the projection viewing mode of operation.

A further object of the present is to provide such a flat display panel assembly as described above, in which the light emission and transmission states of the electro-optical light panel are electronically selectable during the first and second modes of operation, respectively.

A further object of the present invention is to provide a flat display panel as described above, in which the electro-optical light panel is realized as a polymer dispersed liquid crystal (PDLC) panel assembly having a light-diffusive state of operation that is electronically selectable during the direct viewing mode, and also a light non-diffusive state of operation that is electronically selectable during the projection viewing mode of operation, without removal or other physical modification of the light panel.

A further object of the present invention is to provide a flat display panel construction different from the display panel described

above, in which the electro-optical light panel is realized as a
electroluminescent (EO) panel assembly having a layer of
electroluminescent material that emits light from the panel during the
direct viewing mode, and permits externally generated light to pass
5 through the electro-luminescent panel during the projection viewing
mode without substantial scattering.

A further object of the present invention is to provide a novel
computer-based image display system which incorporates such a
display panel assembly construction, and can be easily reconfigured for
10 its projection viewing mode of operation without physical modification
to the display panel assembly construction.

A further object of the present invention is to provide such a
portable computer-based image display system with a housing having a
light aperture that permits an external source of intense light to pass
15 directly through the display panel assembly in order to project focused
video images therefrom onto a desired viewing surface.

A further object of the present invention is to provide such a
portable computer-based image display system with a hinged housing
panel disposed behind the display panel assembly for supporting a light
20 reflective panel and covering the light aperture when the system is
operated in its direct viewing mode.

A further object of the present invention is to provide such a
portable computer-based image display system, in which a film slide or
optical transparency carrying imagery can be placed upon the display
25 surface of the display panel assembly of the present invention and the
imagery viewed in either the direct or projection viewing mode.

A further object of the present invention is to provide a portable
computer-based image display system having both direct and projection

viewing modes of operation, in which "spatially-multiplexed" images of 3-D objects or imagery are viewable through an LCD display panel during the direct viewing mode, and viewable on a wall surface or projection screen during the projection viewing mode, so as to permit the 3-D object to be perceived with stereoscopic depth sensation when the spatially-multiplexed images are viewed through polarized viewing spectacles.

A further object of the present invention is to provide a portable image display system having both direct and projection viewing modes of operation so that it is capable of selectively displaying color video images on its display surface during its direct viewing mode, and projecting such video images onto a projection display surface during its projection viewing mode.

A further object of the present invention is to provide a portable pen-computing device capable of supporting pen-based data entry operations and stereoscopic image display in both direct and projection viewing modes of operation.

A further object of the present invention is to provide a portable light projection accessory device that is particularly adapted for use with the portable computer-based systems of the present invention.

A further object of the present invention is to provide such a portable light projection device having first and second housing portions that are interconnected by a foldable structure that permits these housing portions to be selectively reconfigured for use during the projection viewing mode of operation, and for compact storage during the direct viewing mode of operation.

A further object of the present invention is to provide such a portable light projection device, wherein the first housing portion

contains an intense light source and a light polarizing filter for producing an intense source of polarized light, and an optics assembly for projecting the produced polarized light, and wherein the second housing portion contains an image projection lens that can be adjustably
5 positioned with respect to the display panel assembly thereof for projecting a focused video image onto a desired viewing surface.

A further object of the present invention is to provide a method of projecting images from such a portable computer-based system, by moving the rear housing panel away from the display panel assembly,
10 positioning an external projection lens in front of the display panel assembly, electrically selecting the projection viewing mode of operation for the display assembly, and projecting an intense source of polarized light through the display panel assembly so that when the intense polarized light rays pass through the display panel assembly and are
15 optically processed thereby and focused by the projection lens, a focused video image is projected onto a desired viewing surface.

An even further object of the present invention is to provide such a computer-based image display system in the form of either a palmtop, laptop or notebook computer, personal digital assistant or personal
20 communicator which, with the portable light projecting device hereof, can be easily stored and transported in a lightweight carrying case having physical dimensions on the same order as the portable computer itself.

These and other objects of the present invention will become
25 apparent hereafter.

BRIEF DESCRIPTION OF THE DRAWINGS

For a more complete understanding of the present invention, the
5 Best Modes For Carrying Out The Present Invention is to be read in
conjunction with the accompanying Drawings, in which:

Fig. 1 is a first perspective view of the portable computer-based
system of the first illustrative embodiment of the present invention,
shown arranged in its direct viewing configuration;

10 Fig. 1A is a second perspective view of the portable computer-
based system of Fig. 1, shown arranged in its direct viewing
configuration;

Fig. 2 is a block system diagram of the portable image display
system shown in Figs. 1 and 1A;

15 Fig. 3 is a schematic representation of the image display
subsystem of the portable computer system of the first illustrative
embodiment, shown in its direct viewing configuration;

Fig. 3A is a cross-sectional view of the display panel assembly of
the first illustrative embodiment, taken along line 3A-3A of Fig. 3,
20 showing the electro-optical light diffusing panels thereof being
constructed in accordance with a first manufacturing technique;

Fig. 3B is a cross-sectional view of the display panel assembly of
the second illustrative embodiment, taken along line 3B-3B of Fig. 3,
showing the electro-optical light diffusing panels thereof being
25 constructed in accordance with a second manufacturing technique;

Fig. 3C is an enlarged cross-sectional view of a portion of an
electro-optical light diffusing panel in the display panel assembly of Fig.
3, shown during the direct viewing mode;

Fig. 3D is a schematic representation of an electrode pattern formed on one of the surfaces of the light guiding structure of the display panel assembly of Figs. 3A or 3B in order to achieve light intensity compensation thereacross during the direct viewing mode;

5 Fig. 3E is a cross-sectional view of the light guiding structure employing the electrode pattern of Fig. 3D;

Fig. 4 is a perspective view of the portable computer-based system of the first illustrative embodiment, shown arranged in its first projection viewing configuration;

10 Fig. 4A is an elevated side view of the portable computer-based system of the first illustrative embodiment, shown arranged in its first projection viewing configuration;

Fig. 4B is an elevated side view of the portable computer-based system of the first illustrative embodiment, shown arranged in its
15 second projection viewing configuration using an alternative embodiment of the portable light projecting device of the present invention;

Fig. 5 is a schematic representation of the image display subsystem of the portable computer system of the first illustrative
20 embodiment, shown in its projection viewing configuration;

Fig. 5A is a cross-sectional view of the image display panel assembly of the first illustrative embodiment, taken along line 5A-5A of Fig. 5, showing the electro-optical light diffusing panels thereof being constructed in accordance with a first manufacturing technique of the
25 present invention;

Fig. 5B is a cross-sectional view of the display panel assembly of the second illustrative embodiment, taken along line 5B-5B of Fig. 5, showing the electro-optical light diffusing panels thereof being

constructed in accordance with a second manufacturing technique of the present invention;

Fig. 5C is an enlarged, cross-sectional view of a portion of an electro-optical light diffusing panel in the display panel assembly of Fig. 5, shown during the projection viewing mode;

Fig. 6A is a perspective view of the portable accessory device of the present invention, shown arranged in its compact storage configuration;

Fig. 6B is a perspective view of the portable light projection device of the present invention, shown partially extended but not completely arranged in its light projecting and image focusing configuration;

Fig. 7 is a schematic diagram of the first housing portion of the portable light projecting device of the present invention, showing various subcomponents contained within this portion of the device;

Fig. 8 is a perspective view of the second housing portion of the portable light projecting device of the present invention, showing the various subcomponents contained within this portion of the device;

Fig. 9 is a first perspective view of the portable computer-based system of the second illustrative embodiment of the present invention, shown configured for direct stereoscopic image viewing, and also illustrating the removal of the light reflective back panel from the hinged display portion of the housing;

Fig. 10 is a perspective view of the portable computer-based system of the second illustrative embodiment, shown arranged in its projection viewing configuration, upon a conventional overhead image projector, with its light reflective back panel removed as shown in Fig. 9, for stereoscopic image projection;

Fig. 10A is an elevated side view of the portable computer-based

system of the second illustrative embodiment, shown arranged in its projection viewing configuration, upon a conventional overhead image projector of Fig. 10, for stereoscopic image projection;

Fig. 11 is a schematic representation of the image display
5 subsystem of the portable computer-based system of Fig. 10, shown with its display panel assembly configured in its projection viewing mode of operation;

Fig. 11A is a cross-sectional view of the display panel assembly of the second illustrative embodiment of the present invention, taken
10 along line 11A-11A of Fig. 11, showing the electro-optical light diffusing panels thereof being constructed in accordance with a first manufacturing technique of the present invention;

Fig. 11B is a cross-sectional view of the display panel assembly, taken along line 11B-11B of Fig. 11, showing the electro-optical light
15 diffusing panels thereof being constructed in accordance with a second manufacturing technique of the present invention;

Fig. 11C is an enlarged, cross-sectional view of a portion of the electro-optical light diffusing panel in the display panel assembly of Fig. 11, shown during the projection viewing mode;

20 Fig. 12 is a perspective view of the portable image display device of the present invention being used to directly view imagery recorded in a film structure (e.g. film slide) while operated in its backlighting mode;

Fig. 12A is a perspective view of the image display device of Fig.
25 12, shown interfaced with a conventional computer system while being operated in its direct viewing mode;

Fig. 12B is a perspective view of the image display device of Fig. 12, shown interfaced with a conventional computer system while being

operated in its projection viewing mode;

Fig. 12C is a cross-sectional view of the image display panel assembly of the third illustrative embodiment, taken along line 12C-12C of Fig. 12;

5 Fig. 12D is a cross-sectional view of the display panel assembly of the fourth illustrative embodiment, also taken along line 12C-12C of Fig. 12;

10 Fig. 13 is a perspective view of the portable pen-computing device of the present invention, shown being used in its pen-type data entry mode of operation, and direct viewing modes of operation;

Fig. 13A is a cross-sectional view of the portable pen computing device of the present invention, taken along line 13A-13A of Fig. 13, showing in greater detail the construction of the display/touch-screen panel assembly employed therein;

15 Fig. 13 B is a perspective view of the portable pen-computing device of the present invention, shown being operated in its projection viewing mode;

20 Fig. 14 is a perspective view of yet another embodiment of the electro-optical backlighting panel of the present invention, realized using electroluminescent materials;

Fig. 14A is a cross sectional view of the electro-optical backlighting panel of Fig. 14;

25 Fig. 15 is an elevated side view of a portable computer-based system of another illustrative embodiment of the present invention, shown arranged in its projection viewing configuration;

Fig. 15A is a perspective view of the portable computer-based system of Fig. 15, showing the image projection lens and removable support structure being removed from its internal storage compartment

disposed beneath the central lower base portion of the computer system;

Fig. 15B is a perspective view of the portable computer-based system of Fig. 15, showing the image projection lens supported along the projection axis of the display panel assembly hereof by way of the removable support structure mounted with the support slot formed in the base portion of the computer system;

Fig. 16 is a schematic diagram of a transportable image display system of another illustrative embodiment of the present invention, having both a direct viewing mode of operation during which spatially-multiplexed images are displayed on the surface of its electro-optical light panel for stereoscopic 3-D viewing, and a projection viewing mode of operation during which spatially-multiplexed images are projected onto a projection viewing surface for stereoscopic 3-D viewing; and

Fig. 17 is a schematic diagram of a transportable image display system of yet another illustrative embodiment of the present invention, having both a direct viewing mode of operation during which spatially-multiplexed images are displayed on the surface of its electro-optical light panel for stereoscopic 3-D viewing, and a projection viewing mode of operation during which spatially-multiplexed images are projected onto a projection viewing surface for stereoscopic 3-D viewing.

BEST MODES FOR CARRYING OUT THE PRESENT INVENTION

In general, the electro-optical light panel (e.g. backlighting panel) of the present invention can be used in various image display environments. For purposes of illustration, the light panel of the present invention is shown incorporated as a component in various portable computer-based systems, namely: the portable notebook/laptop computer illustrated in Figs. 1 to 5C; the portable notebook/laptop computer illustrated in Figs. 9 to 11C; the portable image display device illustrated in Figs. 12 to 12 E; the portable pen-computing device illustrated in Figs. 13 to 13B; the portable notebook/laptop computer illustrated in Figs. 15 and 15A; and the portable image display systems in Figs. 16 and 17. It is understood, however, that the electro-optical backlighting panel of the present invention may be used with other types of computer-based systems and equipment, including computer monitors, optical transparencies, film structures and the like, without departing from the scope and spirit of the present invention.

In general, the light panel of the present invention comprises an electro-optical structure having a light emission state in which light is emitted therefrom, and a light transmission state which permits the electro-optical structure to pass externally generated light therethrough without substantial scattering. In many embodiments, the electro-optical structure will be realized in the form of a thin electro-optical panel having first and second modes of operation. Electronic circuitry is provided for selecting the light emission state during the first mode of operation, and the light transmission state during the second mode of operation. The electro-optical backlighting panel is particularly suited

for use in various applications where backlighting illumination is required or desired.

The electro-optical light panel of the present invention may be realized in a variety ways, using a variety of technologies, without
5 departing from the scope or spirit of the present invention. Such technology may include, for example, the use of polymer-dispersed liquid crystal (PDLC) or electroluminescent (EO) materials, but of course is not limited to such electro-optical technologies.

In accordance with one illustrative embodiment of the present
10 invention, the light panel is realized by integrating several components, namely: a light producing means; a light guiding structure; a light diffusing structure, and a state selection means. The light guiding structure is formed from optically transparent material and has first and second light guiding surfaces and at least a first light conducting
15 edge. The function of the light producing means is to produce visible light for transmission through the light conducting edge and internal reflection between the first and second light guiding surfaces. The light guiding structure. The light diffusing structure is operably associated with the light guiding structure, and has a light scattering (i.e. diffusing)
20 optically transparent state of operation which is selectable during the direct viewing mode, and a light non-scattering optically transparent state of operation which is selectable during the projection viewing mode. In this particular embodiment, the function of the state selection means is to select the light scattering state during the direct viewing
25 mode, and the light non-scattering state during the projection viewing mode. In the preferred embodiments of the present invention, the state selection means is realized so as to enable electronic switching of the light diffusing structure from its light scattering state of operation, to its

light non-scattering state of operation.

During the direct viewing mode, a light reflective surface is disposed adjacent the second light guiding surface of the light guiding structure, and the light producing means produces visible light for transmission through the light conducting edge and into the light guiding structure, wherein it is totally internally reflected between the first and second light guiding surfaces thereof. In the direct viewing mode, the state selection means electronically switches the light diffusing structure to its the light scattering state of operation. While operated in its light scattering state, the light diffusing structure scatters light rays internally reflected within the light guiding panel, and as such, a certain percentage of these scattered light rays are no longer satisfy the conditions for total internal reflection within the light guiding panel. Consequently, these scattered light rays are permitted to pass or leak through the first light guiding surface of the light guiding panel, and direct illuminate optical transparencies, film structures, flat LCD panels and the like.

During the projection viewing mode, the light reflective surface is not disposed adjacent the second light guiding surface of the light diffusing structure, and light is typically not produced from the light producing means. Rather, light is produced from an external light source and projected through the light guiding panel. Without physically removing the light diffusing structure from the light guiding panel, the state selection means electronically switches the light diffusing structure to its the light non-scattering state of operation. While operated in its light non-scattering state, the light diffusing structure permits the projected light rays to pass freely through the light guiding structure and light diffusing structure, without substantial

scattering. Consequently, the projected light rays emerging from the backlighting panel can be used to illuminate optical transparencies, film structures, flat LCD panels and the like, and project images on large viewing surfaces.

5 Alternatively, the electro-optical light panel of the present invention can be realized as an electroluminescent panel assembly having a layer of electroluminescent material that emits light from the panel during the direct viewing mode, and permits externally generated light to pass through the electroluminescent panel during the projection
10 viewing mode without substantial scattering. With this alternative method of construction, a special choice of electroluminescent materials, rather than PDLC materials, are used to achieve the light emission and transmission states of the electro-optical light panel.

In general, the light panel of the present invention can be used in
15 many different applications requiring illumination of optical transparencies, film structures, flat LCD panels and the like. However, for purposes of illustration only, light panel of the present invention will be described in great detail with reference to several computer-based embodiments described below.

20 With the above overview of the present invention in mind, the illustrative embodiments thereof will now be described in detail below. Notably, throughout the drawings, like figures shall be indicated with like reference numbers.

As shown in Figs. 1 and 1A, portable computer system 1 includes
25 a housing having a base portion 2 and a hingedly connected display (or cover) portion 3. As illustrated in Fig. 2, portable computer system 1 comprises a number of integrated system components, namely: one or more central processing units 4 (e.g. microprocessors); high-speed

random access memory storage device (e.g. RAM) 5 for storing system parameters, operating system routines, application programs, and the like during execution; a high-speed read only memory device (e.g. ROM) 6 for storing portions of an operating system program; a hard-disc drive subsystem 7 for reading and writing onto hard-type magnetic or opto-magnetic discs, information files, programs, image data and the like for long term storage; a floppy-disc drive subsystem 8 for reading and writing onto floppy-type magnetic discs, information files, programs, image data and the like for long term storage; a visual display subsystem 9 including a LCD display panel assembly 10 and X and Y driver circuitry 11 shown in Figs 3 and 3A; a video image storage subsystem including a video random access memory device (e.g., VRAM) 12 for buffering frames of video data to be displayed on the display panel assembly, and a display processor 13 for accessing frames of video data stored in VRAM 12 and providing these video frames to the X and Y driver circuitry 11; a keyboard or other text input device 14 and associated interface circuitry; a pointing and selecting device (e.g. mouse or track-ball) 15 and interface circuitry and an external input/output port 16 for interfacing one or more input or output devices, such as CD-ROM (optical disc) player, stereo-video camera, facsimile unit, and the like. As illustrated, each of these system components is operably associated with processor(s) 4 by way of one or more system buses 17 in a manner known in the art. In addition, the computer system also includes a rechargeable battery pack 18 and power distribution circuitry 19 well known in the portable computing art.

In the preferred embodiment, the operating system may be realized by Macintosh ® System 7.0 operating system software from

Apple Computer, Inc., Windows ® operating system software from Microsoft Corporation, or UNIX® X-Windows operating system software from AT&T, allowing the processors to support a plurality of input/output windows, pointing and selecting device 15, and multi-
5 media input and output devices. It is understood, however, that other suitable operating system programs can be used with acceptable results without departing from the scope and spirit of the present invention.

In the first illustrative embodiment of the computer-based
10 system, all of the above-described system components, except for display panel assembly 10, are contained in the base portion of the computer housing shown in Figs. 1 and 1A, and only display panel assembly 10 is mounted within the hinged cover portion of the housing. It is understood, however, the particular distribution of system
15 components will vary from embodiment to embodiment of the present invention.

As shown in Figs. 1 and 1A, both the front and rear sides of cover
3 have an rectangular light transmission apertures 20A and 20B formed therethrough. The size of these apertures are substantially the same,
20 yet slightly smaller in length and width dimensions than display panel assembly 10 of the present invention in order to support the perimetrical edges of the display panel assembly in a conventional manner known in the art. In the first illustrative embodiment, an optically opaque rear panel 21 is hingedly connected to the rear portion
25 of the cover so as to completely close off light transmission aperture 20B when panel 21 is rotated downwardly into its direct viewing configuration shown in Fig. 1A. When rotated upwardly in order to arranged the portable computer into its projection viewing configuration

as shown in Fig. 4, rear panel 21 is held in position at a 45 degree angle with respect to the plane of display panel assembly 10. The dimensions of rear panel 21 are slightly smaller than the dimensions of the rear aperture 20B.

5 As shown in the direct viewing configuration of Figs. 3 and 3A, display panel assembly 10 is constructed by integrating a first illustrative embodiment of the electro-optical backlighting panel of the present invention with a programmable spatial light modulator (SLM), realized as a conventional LCD panel 33. As illustrated in these
10 drawings, the first illustrative embodiment of the light panel comprises a number of subcomponents, namely: a light guiding structure 25 in the form of a first polymer dispersed liquid crystal (PDLC) panel (25) consisting of a pair of spaced apart, optically transparent panels 25A and 25B having exteriorly disposed light guiding surfaces 25C and 25D
15 and interiorly disposed surfaces 25E and 25F, a uniformly thick layer of polymer-dispersed liquid crystal material 26 deposited between panels 25A and 25B; a pair of fluorescent lighting tubes 27 and 28 electrically connected to power supply 19 and controlled by processor 4; elongated concave light reflectors 29 and 30; a second PDLC panel 31 affixed to the
20 front surface of light guiding structure 25 with an ultra-thin air gap 32 disposed therebetween; a third PDLC panel 34 affixed to the rear surface of second PDLC panel 31 with an ultra-thin air gap 35 therebetween; a fourth PDLC panel 36 affixed to the rear surface of light guiding structure 25 with an ultra-thin air gap 37 therebetween; and a
25 thin lens panel, realized as a Fresnel lens zone structure or holographic optical lens element in a thin optically transparent layer 38 directed laminated onto the rear surface of the fourth PDLC panel 36, with an ultra-thin air gap 39 therebetween. Together, panels 25, 31, 34, 36 and

38 form the electro-optical backlighting panel of the first illustrative embodiment. As shown in Fig. 3A, active-matrix LCD display panel 33 is affixed to the rear surface of the front surface of second PDLC panel 34 with an ultra-thin air gap 50 disposed therebetween. Alternatively, thin lens panel 38 may be disposed between second PDLC panel 34 and LCD display panel 33 with an appropriate air gap formed between PDLC panel 34 and thin lens panel 38. As such, panels 25, 31, 33, 34, 36 and 38 are integrally connected together to form as a single composite structure, display panel assembly 10. In the preferred embodiment, the overall thickness of this composite structure is less than 10 millimeters. Ultra-thin air gaps 32, 35, 37, 39 and 50 can be formed by very thin panel spacers realized as dimples formed in respective panels or any other suitable techniques known in the art.

While PDLC material is used in the illustrative embodiment to form the light diffusive structure of the present invention, it is understood that other suitable electro-optical structures, having switchable light scattering and non-light scattering states of operation, may be used.

As shown in Figs 3 and 3A, a reflective layer 40 is applied to the inner surface of rear panel 21, which is hingedly connected to the computer display (or cover) portion. In the direct viewing mode, reflective layer 40 is disposed adjacent Fresnel lens panel 38 with an air gap 41 disposed therebetween, whereas reflective layer 40 and rear panel 21 are removed away from display panel assembly 10 during the projection viewing mode shown in Figs. 5 and 5C.

In the first illustrative embodiment, light guiding structure 25 has a thickness in the range of from about 1 to about 5 millimeters.

Fluorescent lighting tubes 27 and 28 are driven by power supply 19

and supported in miniature fixtures well known in the art. The lighting tubes are closely positioned along and in close proximity with opposing side edges of light guiding structure 25. Light rays emitted from these lighting tubes are focused by reflectors 28 and 29 along the side edges of the light guiding structure, and effectively conducted into the interior of the light guiding structure so that they are normally bounded (i.e. internally reflected) between light guiding surfaces 25A and 25B in accordance with the well known optical principle of "total internal reflection".

10 Particularly during the direct viewing mode of operation, it is necessary that the light trapped within the light guiding structure be uniformly extracted or "leaked out" in the direction of the LCD panel 33. By doing so, only LCD panel 33 is allowed to spatially modulate (and spectrally filter) the light intensity distribution produced from the backlighting panel and display color imagery. In accordance with the present invention, this function is performed by electrically-controlling the first PDLC panel 25 (i.e. light guiding structure) so that it interrupts the total internal reflection of the light guided between the light guiding surfaces 25C and 25D of the light guiding structure. In the illustrative embodiment, this function is realized by coating the opposing interior surfaces 25E and 25F of optically transparent panels 25A and 25B with optically transparent electrically-conductive layers 42 and 43 (e.g. Indium Tin Oxide) having ultra-thin dimensions (e.g. 1000 to 5000 Angstroms). As best shown in Fig. 3C, PDLC layer 26 is disposed between these electrically-conductive layers. Importantly, specific optical materials are selected so that optically transparent panels 25A and 25B and cured polymer matrix 44 therebetween (suspending liquid crystal molecules 45) have identical indices of refraction.

As best shown in Fig. 3C, during the direct viewing mode, no external electric field (i.e. voltage) is applied across electrode surfaces 42 and 43. Under such conditions, the electric field vectors of polymer-dispersed liquid crystals 45 between electrode surfaces 42 and 42 are randomly oriented and light rays reflected between light guiding surfaces 25C and 25D are scattered in accordance with the well known Lambertian distribution. Those scattered light rays no longer satisfying the critical angle for total internal reflection are transmitted directly through both light guiding surfaces 25C and 25D.

As shown in Fig. 5C, during the projection mode an external field (i.e. voltage) is applied across electrode surfaces 42 and 43, causing the PDLC molecules to align in the direction of the electric field, perpendicular to the light guiding surfaces 25C and 25D, and thereby eliminates light scattering. During this mode of operation, the PDLC panel assumes its light non-scattering state so that the condition of total internal reflection is satisfied, with substantially no light leaking from the light guiding structure. Only externally generated light rays, propagating substantially perpendicular to the light guiding surfaces of the light guiding structure, are permitted to pass completely through the backlighting panel onto LCD panel 33. To switch the display system to its direct viewing mode, all that is required is to remove the voltage (i.e. external field) applied across electrode surfaces 42 and 43, causing PDLC panel 26 to revert back to its light scattering (i.e. diffusive) state of operation.

In order to ensure that the light leaked out through the front surface of the light guiding panel 25 is substantially uniform, it is necessary to compensate for the inherent decrease in conducted light intensity in the direction of the central axis of the light conductive

panel. In the illustrative embodiments of the present invention, this compensation function can be achieved using any one of the techniques described below.

A first method of light intensity compensation involves

5 distributing the liquid crystal molecules within the PDLC 26 as a function of distance across the horizontal dimensions of the light guiding panel. Specifically, in the dual fluorescent tube configuration of the first illustrative embodiment, the density of liquid crystals is made to be greater towards the center of the light guiding panel 25 where the

10 intensity of conducted light is least. By doing so, compensation for diminishing light intensity can be achieved. This technique can be carried out by preparing an emulsion of PDLC material formed from polyvinyl acetate (PVA), polymethyl methacrylate (PMMA) or other suitable polymer material, all well known in the art. Then liquid crystal

15 molecules are added to the emulsion. Using the prepared emulsion and screen printing techniques well known in the art, a pattern of PDLC emulsion material is formed on optically transparent electrode surface 42 or 43. Notably, the geometry of the PDLC emulsion pattern will be selected with consideration to light intensity compensation across the

20 backlighting panel. Thereafter during PDLC film formation, microdroplets are formed spontaneously in the resulting PDLC film using a phase separation process. The phase separation can be induced by polymerization, temperature, or a combination of solvent and temperature. In particular, a phase-separation technique, such as

25 Polymerization-Induced Phase Separation(PIPS), Thermally-Induced Phase Separation(TIPS) or Solvent-Induced Phase Separation can be used to form liquid crystal microdroplets dispersed in the PDLC film structure. The PDLC film is fixed (i.e. cured) using UV radiation with

photo-initiators, both well known in the art. Finally, a layer of PVA or PMMA is applied over the fixed patterned PDLC film layer in order to fill-in the gaps between the pattern and form an optically smooth surface.

5 When the light guiding structure 25 is completely fabricated, there should be complete index refraction matching from light guiding surface 25C to light guiding surface 25D. While this optical condition must be satisfied to ensure optimal performance of the light guiding structure, it is understood that the choice of materials and fabrication
10 techniques used to realize this structure may vary from embodiment to embodiment.

A second method of light intensity compensation illustrated in Figs 3D and 3E involves forming (i) primary and secondary sets of interleaved (optically-transparent) electrode strips 42A and 42B on the
15 interiorly disposed surface 25E of optically transparent panel 25A, and (ii) a uniform optically transparent electrode surface 43 on the interiorly disposed surface 25F of optically transparent panel 25B. As shown in Figs 3D and 3E, electrode strips 42A and 42 B extend parallel to the vertical direction of light guiding structure 25. Electrode strips
20 42A are electrically connected to a bus strip 42C, whereas electrode strips 42B are electrically connected to bus strip 42D. As shown in Fig. 3D, an unpatterned uniform PDLC layer 26' is formed between these electrode surface structures. In order to cause greater light scattering towards the central region of the light guiding structure and thus
25 compensate for light intensity in this region, the width of the interleaved electrode strips 42A and 42B increases a towards the center of the light guiding structure, as shown. In general, the width of the gap between adjacent electrode strips is substantially smaller than the

width of the electrode strips. This ensures that during the projection viewing mode, when an external electric field is applied across both the primary and secondary sets of electrode strips and all liquid crystal molecules align therewith and pose no light scattering in this state of operation perturbations in the electric field intensity is negligible at the fringe areas of the electrode surfaces. Also, the thickness of the PDLC layer 26 is made substantially smaller than the width of the narrowest electric strip to ensure that the electric field between the electrode strip and the ground electrode surface is substantially uniform.

10 In the direct viewing mode, it is essential that light internally reflected between light guiding surfaces 25C and 25D is permitted to escape or leak out towards LCD panel 33. During the direct viewing mode, internally reflected light is permitted to escape light guiding structure by applying an external field only across the secondary set of electrode strips 42B. In response, the electric field vectors of the liquid crystal molecules below the secondary set of electrode strips 42B, are randomly oriented and a pattern of non-scattering liquid crystal molecules are formed. Between the primary set of electrode strips 42A and the uniform electrode surface 43, across which no electric field is applied, the electric field vectors of the liquid crystal molecules are randomly oriented and light scattering occurs. Naturally, during the direct viewing mode, a greater degree of light scattering occurs under the wider electrode strips of the primary set of electrodes 42A, than under the narrower electrode strips in the primary set. Collectively, the resulting light scattering pattern so formed provides the degree of light intensity compensation required for high quality imaging through LCD panel 33.

A third method of light intensity compensation is illustrated in the

drawings of Figs. 3F to 3H. As shown in Fig. 3F, the first step of the method involves providing a uniform layer of PDLC film 26' between a pair of unpatterned optically transparent electrode layers 42 and 43. Typically, each optically transparent electrode layer is formed from a material such as Indium Tin Oxide. Preferably, PDLC film layer 26' consists of a distribution of encapsulated liquid crystal microdroplets (i.e. "liquid crystal microdroplets") with diameters of about 0.1 to about 10 microns, surrounded by or uniformly dispersed in a light transmissive matrix of photo-sensitive polymer, such as Norland Photopolymer, commercially available from Norland, Inc., of New Jersey.

At this stage of the manufacturing process, a suitable emulsion for the PDLC film must be prepared. In the illustrative embodiment, the first step in preparing the emulsion involves forming a homogeneous, fairly viscous solution formed by intermixing nematic, smectic or cholesteric liquid crystal molecules with appropriate liquid polymer precursors (e.g. prepolymer or monomer) and curing agent, such as liquid UV photo-initiator. Suitable materials for use in preparing the homogeneous solution are well known to those with ordinary skill in the art. Also well known details regarding PDLC film manufacture are disclosed in the paper "Polymer-Dispersed and Encapsulated Liquid Crystal Films" by G. Paul Montgomery, Jr., published in Large-Area Chromogenics: Materials and Devices for Transmittance Control, SPIE Institute Series Vol. IS 4, pages 577-606, incorporated herein by reference in its entirety. Once prepared, the viscous solution can be applied between a pair of substrates coated with optically transparent conducting electrode layers 42 and 43, to form a film emulsion structure of the required thickness. Typically, Indium Tin Oxide (ITO) is used to form optically transparent electrode layers 42 and 43.

In general, microdroplets in the PDLC film emulsion structure are formed spontaneously by a phase separation process which occurs during film formation. The phase separation can be induced by polymerization, temperature, or a combination of solvent and

5 temperature. In particular, a phase-separation technique, such as Polymerization-Induced Phase Separation (PIPS), Thermally-Induced Phase Separation (TIPS) or Solvent-Induced Phase Separation can be used to form liquid crystal microdroplets dispersed in the PDLC film structure.

10 In the illustrative embodiment, the liquid phase encapsulated within each liquid crystal microdroplet generally comprises: (i) a large percentage of liquid crystal molecules (e.g. about 99% by volume); (ii) a very small percentage of liquid prepolymer or monomer (e.g. less than 1.0 % by volume); and (ii) a very small percentage of curing agent, such

15 as liquid photo-initiator (e.g. less than 1.0% by volume). While the encapsulated liquid crystals may be of the nematic, smectic or cholesteric type, nematic liquid crystals are the preferred light scattering medium in the illustrative embodiments. Upon completing this stage of the manufacturing process, the substrates are removed to

20 provide a PDLC film structure having a thin layer of PDLC film sandwiched between optically transparent, conducting electrode layers 42 and 43. The length and width dimensions of the resulting PDLC film structure may be large or small depending upon the commercial application.

25 As shown in Fig. 3G, the second step of the method involves exposing the entire PDLC film structure to a pattern of ultra-violet(UV) light projected using spatial mask 140 and UV light projector 141, while a "reference" electric field, directed substantially perpendicular to the

plane of the PDLC film structure, is applied across optically transparent electrode layers 42 and 43 in order to align the optical axis of each liquid crystal microdroplet parallel therewith. Preferably, the pattern of light transmission apertures 140A in spatial mask 140 is substantially similar to the electrode pattern shown in Fig. 3D. During this stage of the manufacturing process, several chemical reactions occur. Firstly, those portions of the photo-sensitive polymer matrix (i.e. PDLC film structure) that have been exposed to the UV light pattern become cured. Secondly, the monomer material in the liquid crystal microdroplets that have been exposed to the UV light pattern becomes polymerized in the presence of the photo-initiator and UV light, thereby forming a polymer network in each such liquid crystal microdroplet. The function of the polymer network within each microdroplet is to physically entrap the liquid crystal molecules therewithin so that the optical axis of the microdroplet is elastically biased or aligned parallel to the direction of the reference electric field (i.e. perpendicular to the plane of PDLC film layer). During this stage of the manufacturing process, the regions of the PDLC film structure that are blocked by the spatial mask, do not cure in the absence of UV light. The result of this step of the manufacturing process is the formation of a first pattern of polymer-dispersed liquid crystal microdroplets whose optical axes are elastically biased in a direction perpendicular to the plane of the PDLC film structure.

As shown in Fig. 3H, the third step of the method involves first removing the reference electric field from across the electrode layers 42 and 43. In the absence of an external electric field, the optical axes of the microdroplets blocked from the UV light pattern during the previous stage, are now permitted to orient their respective optical axes

in a random manner within the photo-sensitive polymer matrix. Then, the entire PDLC film structure is exposed to ultra-violet(UV) light using the UV light projector 141 (without spatial mask 140), while the "reference" electric field is removed from across electrode layers 42 and 43. During this stage of the manufacturing process, several photo-chemical reactions occur. Firstly, the remainder of the photo-sensitive polymer matrix is cured. Secondly, monomer material in microdroplets with randomly oriented optical axes, becomes polymerized in the presence of the photo-initiator and UV light, thereby forming a polymer (i.e. polydomain) network in each such microdroplet. The function of the polymer network within each such microdroplet is to physically entrap the liquid crystal molecules therewithin so that the optical axis of each microdroplet is elastically biased in a random orientation.

The resulting structure is a PDLC panel having a first pattern of polymer-dispersed liquid crystal microdroplets whose optical axes are elastically biased in a direction perpendicular to the plane of the PDLC panel, and a second pattern of polymer-dispersed liquid crystal microdroplets whose optical axes are elastically biased in directions that are random with respect to the plane of the PDLC panel.

When there is no external electric field applied across the electrode layers 42 and 43 of the PDLC panel, the randomly oriented optical axes of the second pattern of liquid crystal microdroplets provide the "light scattering (i.e. diffusing) state" of operation required to extract light from the backlighting panel during the direct viewing mode. At the same time, the second pattern of liquid crystal microdroplets in PDLC panel 26' achieves the desired degree of intensity compensation required in the light panel.

When an external electric force field is applied across the

electrode layers 42 and 43 in a direction perpendicular to the plane of the PDLC panel, the optical axes of second pattern of liquid crystal microdroplets are forcefully reoriented away from their random directions and aligned parallel to the direction of the elastically biased optical axes of the first pattern of liquid crystal microdroplets. This provides the "light non-scattering state" of operation required for non-diffusive passage of projected light during the projection viewing mode.

For the remainder of the description of the present invention, it shall be assumed for exposition purposes only that light intensity compensation in light guiding structure 25 is achieved using a patterned PDLC layer 26 and electrode surfaces 42 and 43, as shown in Figs 3A and 5B and described above. It is understood, however, that the description generally applies when PDLC layers 26', 26" or any other functionally equivalent structure is used for selectively controlling light diffusion in the light panel of the present invention.

In the direct viewing mode of operation, when no applied electric field is applied across electrodes 42 and 43 of the first PDLC panel, the liquid crystal molecules dispersed therein are randomly oriented. Consequently, the light conducted within light guiding structure 25 is scattered the most along the central portion thereof. The result is a substantially uniform light intensity distribution emanating from light guiding structure 25 in the direction of LCD panel 33, as well as in the direction of PDLC panel 31.

To ensure that only LCD panel 33 of the display panel assembly imparts a spatial intensity modulation to the light distribution emanating from the display surface towards the viewer's eyes, it is essential the light intensity behind LCD panel 33 be highly uniform along the x and y coordinates of the display panel assembly. The

function of the PDLC panel 31 is to further ensure that this condition is satisfied by uniformly diffusing (i.e. scattering) light passing through light guiding surface 25D. In the illustrative embodiment, this light diffusion function is achieved by constructing the PDLC panel 31 in a manner similar to that of the first PDLC panel (i.e. light guiding structure 25). Specifically, opposing interior surfaces 31E and 31F of optically transparent panels 31A and 31B are coated with optically transparent electrically-conductive layers 46 and 47 (e.g. , Indium Tin Oxide ITO) having ultra-thin dimensions (e.g. 1000 to 5000 angstroms). As shown, PDLC layer 31G is disposed between these electrically conductive electrode surfaces. In the PDLC panel 31, the distribution (i.e. density) of liquid crystal molecules is substantially uniform across the horizontal dimensions of the panel. The index or refraction of optically transparent panels 31A and 31B and the cured polymer matrix (supporting liquid crystal molecules) therebetween are substantially identical. In the direct viewing mode, when no external electric field is applied across electrode surfaces 46 and 47, the electric field vectors of the polymer-dispersed liquid crystals between these electrode surfaces are randomly oriented and light rays emerging from light guiding structure 25 and passing through the PDLC panel 31 are uniformly scattered in accordance with the well known Lambertian distribution. The result is a highly uniform light intensity distribution emerging from the PDLC panel 31 in the direction of PDLC panel 34. In the projection viewing mode, when an external electric field (i.e. voltage) is applied across electrode surfaces 46 and 47, the electric field vectors of the polymer-dispersed liquid crystals between these electrode surfaces align with the applied electric field, to yield the light non-scattering state of operation. In this switched optical state, light rays projected

perpendicularly through light guiding structure 25 from an external light projector, pass through PDLC panel 31 without scattering, as required to illuminate LCD panel 33 during the projection viewing mode of the display subsystem of the present invention.

5 In display panel assembly 10, the function of the PDLC panel 34 is similar to the function of PDLC panel 31, described above. Specifically, during the direct viewing mode, the function of PDLC panel 34 is to further diffuse (i.e. scatter) light emerging from PDLC panel 31. In the illustrative embodiment, this light diffusion function is achieved by
10 constructing the PDLC panel 34 in a manner identical to that of the PDLC panel 31. Specifically, opposing interior surfaces 34E and 34F of optically transparent panels 34A and 34B are coated with optically transparent electrically-conductive layers 48 and 49 (e.g. Indium Tin Oxide ITO) having ultra-thin dimensions (e.g. 1000 to 5000 Angstroms).
15 As shown, PDLC layer 34G is disposed between these electrically conductive electrode surfaces. In the PDLC panel 34, the distribution (i.e. density) of liquid crystal molecules is substantially uniform across the horizontal dimensions of the panel. The index or refraction of optically transparent panels 34A and 34B and the cured polymer matrix
20 (supporting liquid crystal molecules) therebetween are substantially identical. In the direct viewing mode, when no external electric field is applied across electrode surfaces 48 and 49, the electric field vectors of the polymer-dispersed liquid crystals between these electrode surfaces are randomly oriented and light rays emerging from PDLC panel 31 and
25 passing through the PDLC panel 34 are uniformly scattered in accordance with the well known Lambertian distribution. The result is a very-highly uniform light intensity distribution emerging from the PDLC panel 34 in the direction of LCD panel 33.

In the direct viewing mode, light scattering within the light guiding structure 25 generally occurs in accordance with the well known Lambertian distribution. The scattered light rays propagating in the direction of reflective surface 40 first passes through PDLC panel 36 and Fresnel lens panel 38, reflects off reflective surface 40 and then passes through Fresnel lens panel 38, PDLC panel 36 and light guiding structure 25 prior to passing through PDLC panels 31 and 34 and ultimately onto LCD panel 33. During the direct viewing mode, PDLC panel 36 functions to diffuse this scattered/reflected light as it propagates through light transmission surfaces 36C and 36D of PDLC panel 36. This light diffusion function is achieved by constructing the PDLC panel 36 in a manner similar to that of the PDLC panels 30, 31 and 34. Specifically, opposing interior surfaces 36E and 36F of optically transparent panels 36A and 36B are coated with optically transparent electrically-conductive layers 51 and 52 (e.g., Indium Tin Oxide ITO) having ultra-thin dimensions (e.g. 1000 to 5000 Angstroms). As shown, PDLC layer 36G is disposed between these electrically conductive electrode surfaces. In the PDLC panel 36, the distribution (i.e. density) of liquid crystal molecules is substantially uniform across the horizontal dimensions of the panel. The index of refraction of optically transparent panels 36A and 36B and the cured polymer matrix (supporting liquid crystal molecules) therebetween are substantially identical. In the direct viewing mode, when no external electric field is applied across electrode surfaces 51 and 52, the electric field vectors of the polymer-dispersed liquid crystals between these electrode surfaces are randomly oriented and light rays reflecting off reflective surface 40, and passing through PDLC panel 36 are uniformly scattered in accordance with the well known Lambertian distribution. The result is a highly uniform

light distribution emanating from PDLC panel 36 in the direction of light guiding structure 25.

In the direct viewing mode, the collective function of light guiding structure 25 and electronically-controlled light diffusing panels 31, 34, and 36 is to produce a plane of backlighting having a highly uniform light intensity characteristics along the x and y coordinate directions of LCD panel 33. In order to display imagery of one sort or another from the computer system, LCD panel 33 spatially modulates the intensity of the plane of uniform backlighting as it propagates through the LCD panel.

In the illustrative embodiments, LCD panel 33 comprises a programmable spatial color mask (i.e. spatial spectral mask) disposed over a programmable spatial light intensity mask (i.e. spatial light modulator or SLM). In general, the programmable spatial light mask comprises a first array (i.e. matrix) of electrically addressable pixels, and the programmable spatial color mask comprises a second array of electrically addressable pixels.

In a manner well known in the art, each pixel in the programmable spatial light mask is formed from a material having a light transmittance (over the optical band) which can varied in accordance with pixel intensity information to be displayed. In a conventional manner, each pixel in this spatial light mask is driven by pixel driver circuitry 11 operated under the control of display controller 13. The degree to which the light transmittance of each pixel in the array is modulated, is determined by the gray-scale or intensity information contained in the corresponding pixel location in frame buffer 12. The gray scale information of a particular image to be displayed is written in frame buffer 12 by display processor 13, and is

scanned and converted into pixel drive signals by the pixel driver circuitry 11.

When color images are to be displayed, the programmable spatial color (i.e. spectral) mask is actively driven by pixel driver circuitry 11.

5 Each pixel in the programmable spatial color mask has spectral transmittance characteristics which can varied in accordance with color information to be displayed. In a conventional manner, each of the pixels in the programmable spatial color mask is driven by designated driver lines of X and Y pixel drivers 11. The spectral transmittance
10 characteristics of each pixel in the array are determined by the pixel color information in frame buffer 12.

Having described the first illustrative embodiment of the display panel assembly of the present invention, it is appropriate to describe the second illustrative embodiment thereof designated by reference
15 numeral 10'.

As shown in Figs. 3 and 3B in particular, the display panel assembly 10' comprises a novel electro-optical light panel construction integrated with a conventional LCD display panel. The electro-optical light panel construction comprises a number of integrated components,
20 namely: an optically transparent light guiding panel 25'; fluorescent lighting tubes 27 and 28; elongated concave light reflectors 29 and 30; electrically-controlled PDLC panel 31 directly laminated onto front surface 25B' of light guiding panel 25'; electrically-controlled PDLC panel 34 affixed to the front surface of electrically-controlled PDLC panel 31
25 with an ultra-thin air gap 35 disposed therebetween; electrically-controlled PDLC panel 36 affixed to rear surface 25A' of light guiding panel 25' with an ultra-thin air gap 37 therebetween; and Fresnel lens zone structure formed in a thin optically transparent layer 38 affixed to

the rear surface of electrically-controlled PDLC panel 36 with ultra-thin air gap 39 disposed therebetween. Together, panels 25',31,34,36 and 38 form the electro-optical light panel of composite construction. In the illustrative embodiment, active-matrix LCD display panel 33 is affixed
5 to the front surface of the electrically-controlled PDLC panel 34 with ultra-thin air gap 50 disposed therebetween. As such, panels 25', 31,33, 34, 36 and 38 are integrally connected to form as a single composite structure, display panel assembly 10'. In the preferred embodiment, the overall thickness of this composite structure is less than 10
10 millimeters.

As shown in Figs 3 and 3B, reflective layer 40 is applied to the inner surface of rear panel 21 in substantially the same manner provided in the first illustrative embodiment of the display panel assembly. In the direct viewing mode, reflective layer 40 is disposed
15 adjacent Fresnel lens panel 38, whereas reflective layer 40 and rear panel 21 are removed away from the light panel hereof in the projection viewing mode shown in Figs. 5 to 5B.

In display panel assembly 10', light guiding panel 25' is in the form of solid sheet of material (e.g. PVA or PMMA) having the same
20 index of refraction as optically transparent panels 31A and 31B, and the polymer matrix of PDLC layer 31G disposed therebetween. Preferably, the thickness of light guiding panel 25' is in the range of from about 1 to about 5 millimeters. Electrically controlled PDLC panel 31 is constructed as described above in connection with display panel assembly 10.

25 When light guiding panel 25' and optically transparent panel 31A are secured together by a suitable adhesive, the index of refraction is constant (i.e. substantially the same) from light guiding surface 25A' to light transmission surface 31D of PDLC panel 31.

In display panel assembly 10', fluorescent lighting tubes 27 and 28 are driven by power supply 19 and supported in miniature fixtures attached to the side edges of light guiding panel 25'. The fluorescent tubes are closely positioned along and in close proximity with opposing side edges of light guiding panel 25' so that emitted light from the tubes is focused by reflectors 29 and 30 along the side edges of the light guiding panel and effectively conducted into the interior of light guiding panel 25'. In all other respects, display panel assembly 10' is constructed in a manner similar to display panel assembly 10.

10 In the direct viewing mode of operation, when no applied electric field is applied across electrodes 46 and 47 of PDLC panel 31, the liquid crystal molecules dispersed therein are randomly oriented. Consequently, the conducted light within the light guiding panel 25' is scattered the most along the central portion of PDLC panel 31, with a substantially uniform light intensity distribution emanating from PDLC panel 31 in the direction of PDLC panel 34. In the direct viewing mode, PDLC panels 34 and 36, Fresnel lens panel 38, reflective layer 40, and LCD panel 33 of display panel assembly 10' operate and function in the same manner in display panel assembly 10. In the projection viewing mode, PDLC panels 34 and 36, and LCD panel 33 of display panel assembly 10' operate and function in the same manner in display panel assembly 10.

Computer-based system 1 of the illustrative embodiment has two direct viewing modes of operation, namely: An Illuminated Direct Viewing Mode for directly viewing images displayed on LCD panel 33; and An Illuminated Direct Backlighting Mode for directly viewing optically translucent film structures, such as slides and optical transparencies. Both of these direct viewing modes will be described

below.

Portable computer system 1 is operated in its Illuminated Direct Viewing Mode of operation by performing the following simple operations: (i) moving rear panel 21 and reflective surface 40 against
5 Fresnel lens panel 38 of display panel assembly 10; (ii) electronically reconfiguring display panel assembly 10 into its direct viewing state of operation by not applying an electric field across the optically transparent electrodes of the PDLC panels 25, 31, 34 and 36; and (iii) then driving fluorescent tubes 27 and 28 in order to inject light into
10 light guiding panel 25, while driving LCD panel 33 with pixel drive signals derived from the image data set written into frame buffer 12. However, in certain circumstances it might be desirable to operate the computer system in an alternative direct viewing mode, in which the fluorescent tubes 27 and 28 and light diffusing panels 25, 31, 34 and 36
15 are not driven, and backlighting is provided solely by ambient light passing through the display panel assembly 10 and reflecting off reflective layer 40 in the direction of the viewer of LCD panel 33. This alternative mode of direct viewing is referred to as the Direct Reflection Viewing Mode of operation and is particularly useful when the intensity
20 of ambient light is high, as in outdoor environments, and when electrical power reserves in the portable computer are limited.

Preferably, portable computer system 1 is operated in its Illuminated Direct Backlighting Mode of operation by performing the following simple operations: (i) moving rear panel 21 and reflective
25 surface 40 against Fresnel lens panel 38 of display panel assembly 10; (ii) electronically reconfiguring display panel assembly 10 into its direct viewing state of operation by not applying an electric field across the optically transparent electrodes of the PDLC panels 25, 31, 34 and 36;

and (iii) then driving fluorescent tubes 27 and 28 in order to inject light into light guiding panel 25, while not driving LCD panel 33 with pixel drive signals.

The structure and function of display panel assemblies 10 and 10' have been described above in great detail. It is appropriate at this juncture to now describe the portable light projection device of the present invention.

As shown in Figs 6A to 8, portable light projection device 60 of the present invention comprises a number of structural components, namely: first and second housing portions 61 and 62; and foldable structure 63. As shown in its compact storage configuration in Fig. 6A, first and second housing portions 61 and 62 are releasably joined at their ends in a snap-fit manner. As shown in its partially extended configuration in Fig. 6B, the first and second housing portions are shown interconnected by foldable structure 63. In the illustrative embodiment, first and second housing portions 61 and 62 each have a cubical geometry, while foldable structure 63 is realized as a plurality of hingedly connected panels 63A to 63E. As shown, each panel is hinged to at least one other panel, and one panel is hinged to the bottom of the first housing portion, and another panel is hinged to the bottom of second housing portion. These panels can be folded upon each other in sequence, and then the upper rim 65 of first housing portion connected to the upper groove 66 formed in the second housing portion, as shown in Fig. 6A. When the portable light projection device is needed for the projection viewing mode, the first and second housing portions can be separated and the panels unfolded so that the housing portions are separated by a distance substantially equal to the width of the base of the computer system, as shown in Fig. 4A.

As shown in Fig. 7, first housing portion 61 contains electrical power circuitry 70 for transforming standard household AC power (60 Hz), supplied over electrical wiring 71, to a sufficient level of DC power. Mounted above this circuitry is an electrical socket 72 within which is mounted an incandescent lamp 73. About the lamp is a parabolic light focusing reflector 74. Electrical socket 72 and an ON/OFF switch 75 externally mounted through the side wall of the first housing portion are connected to electrical power circuitry 70. An internal fan unit 76 is connected to electrical power circuitry 70 for maintaining the temperature of the lamp at a safe operating level. Mounted above the light focusing reflector 74 is a polarizing filter panel 77 which polarizes the light produced from lamp. Preferably, polarization filter 77 is manufactured from cholesteric liquid crystal (CLC) material, as disclosed in U.S. Patent No. 5,221,982 to Applicant, which is incorporated by reference in their entirety. While polarizing filter 77 is shown in the form of a panel, the function which it achieves can be realized in a material applied as a coating over a high-intensity light bulb, such as incandescent lamp 73. Significantly, the installation of polarizing filter 77 in the portable light projection device avoids dissipating the power of the undesired polarization component across LCD panel 33 of the LCD panel assembly. Consequently, display panel assembly 10 (and 10') is permitted to operate at lower temperatures without need for cooling or display-panel temperature measures in the portable computer system when operated in its projection viewing mode.

Above the light polarizing panel 77, and below light aperture 68 in housing 61, is an adjustable optics assembly 78 for focusing produced polarized light on the interior surface of the rear panel. Optics assembly 78 includes a lens system mounted in housing portion 61 in a

conventional manner. Preferably, slidable lens mounts are used to support the lenses of this system in a manner that permits adjust of the focal length thereof by rotation of knob 69, external to housing portion 61.

5 As shown in Fig. 6B and 8, the second housing portion contains an optical platform 80 a lens holder 81, light projection lens 82, and first and second platform support sleeves 83 and 84. As shown in Fig. 4A, platform 80 is mounted upon the top portion of platform support 82, whereas platform support sleeves 83 and 84 are telescopically
10 interconnected and joined to the cubic shaped second housing portion 62. As shown in Figs. 4A and 6B, lens holder 81 is slidably mounted within grooves 85 and 86 formed in optical platform 80 such that the position of lens holder 81 along the optical platform can be easily adjusted by simply rotating a knob 87. In the preferred embodiment,
15 knob 87 is operably associated with a platform translation mechanism 88 contained beneath optical platform 80 itself. Within lens 81, image projection lens 82 is securely mounted. With the above described arrangement, image projection lens 82 can be adjustably positioned with respect to LCD panel 33 in order to project a focused video image
20 onto a desired viewing surface.

A method of using portable light projection device 60 with portable computer system 1 will be described below. However, as display panel assemblies 10 and 10' have similar modes of operation, the following description shall be made with reference to portable
25 computer system 1 incorporating display panel assembly 10 into its image display subsystem.

In Figs. 4 and 4A, portable computer system 1 is shown arranged in its first projection viewing configuration using portable light

projection device 60 of the present invention. The first projection viewing configuration is achieved by arranging the portable light projecting device in its extended configuration, about base 2 of the computer system, as shown. Hinged rear housing panel 21 is pulled
5 outwardly away from Fresnel lens panel 38 so that light reflective surface 40 is supported at about a 45 degree position with respect to the Fresnel lens panel by a conventional support mechanism 21A, as shown in Fig. 4A. In projection viewing configuration, the first housing portion 61 of the portable light projecting device is disposed below the
10 reflective surface, while an image projection lens 62 extends from the second housing portion 63.

Once configured as shown in Fig. 4A, portable light projection device 60 is adjusted as follows. First, the lateral position of first housing section 61 is adjusted so that the optical axis of projection lens
15 78 in the first housing portion is aligned under reflective surface 40. Lens holder 81 is then pulled upwardly out of the frictional embrace of the second platform support sleeve 84, as shown in Fig. 6B. Then by pulling further upwardly, the second platform support sleeve 84 slides out of the frictional embrace of the first platform support sleeve 83 and
20 then when further pulled upwardly, the first platform support sleeve slides out of the frictional embrace of the cubic shaped second housing portion, as shown in Fig. 4 A. Then, with power supplied to light source 73 and light emitting therefrom, the position of projection lens 82 along the optical axis of Fresnel lens panel 38 is adjusted so that the images
25 formed on the display surface of LCD panel 33 are projected as enlarged focused images onto large viewing surface 89. In general, projection lens 82 is positioned in front of the display panel assembly at a distance equal to the focal length of Fresnel lens panel 38.

When it is desired to arrange portable light projecting device 60 back into its compact storage configuration, as shown in Fig. 6, lens holder 81 is simply pushed downwardly, to collapse platform support sleeves 83 and 84 in a manner opposite to the telescopic extension

5 process described above. Thereafter, hingedly connected panels 63A to 63E are folded upon each other and finally first housing portion 61 is snap-fit connected to second housing portion 62, to provide a single interconnected unit of physical dimensions of 3" x 3" x 6", as shown in Fig. 6A

10 The geometrical optics that describe the image projection process are graphically illustrated in Fig. 4A. Specifically, during the projection viewing mode, the light rays produced from light source 73 in the first housing portion are first polarized by polarizer 77, and then focused in a divergent manner onto reflective surface 40 by projection lens 78. The

15 polarized light rays are then reflected off reflective surface 40, passed through backlighting construction of display panel assembly 10 with minimal attenuation and ultimately passed through and optically processed by LCD panel 33. The light rays emanating from actively driven LCD panel 33 are spatial intensity modulated and spectrally

20 filtered in accordance with the X,Y drive signals provided to pixel driver circuitry 11, and are then focused by projection lens 82 to produce a focused video image on viewing surface 89, which is typically located at the focal distance of projection lens 82. The structural details of the display panel assembly in the projection viewing configuration are

25 shown in Figs. 5 to 5A.

In Fig. 4B, portable computer system 1 is shown arranged in its second projection viewing configuration using an alternative embodiment of portable light projection device 60 of the present

invention, indicated by reference numeral 60'. All some respects, first housing portion 61' of light projection device 60' is different from that of light projection device 60 shown in Fig. 4A. In particular, the polarized light source contained in the first housing portion of light projection device 60' is telescopically extendable to the height of projection axis 200, and is ported on its side, as shown, to permit direct projection of focused polarized light towards the light panel assembly 10 with its integrated Fresnel lens panel. In all respects, the second housing portion 62 of light projection device 60' is the same as the second housing portion of light projection device 60 shown in Fig. 4A. During transport, both the first and second housing portions are collapsible and then configurable as described in connection with light projection device 60 above.

As shown in Fig. 4B, the second projection viewing configuration is achieved by arranging the portable light projecting device 60' in its extended configuration, about the base of the computer system. Hinged rear housing panel 21 is pulled outwardly away from Fresnel lens panel 38 so that light reflective surface 40 is supported at about a 65 degree position with respect to the Fresnel lens panel by a conventional support mechanism 21A, as shown in Fig. 4B. In the second projection viewing configuration, the first housing portion 61' of the portable light projecting device 60' is disposed below the reflective surface and along the optical projection axis 200 of the Fresnel lens panel, while an image projection lens 82 is telescopically extended from the second housing portion 62 and is aligned along the optical projection axis, as shown. In this alternative embodiment, first housing portion 61' includes a polarized light source 73, 77 of the type disclosed in Fig. 7, which projects a diverging yet focused beam of polarized light directly through

the display panel 10, without the need to reflect off the reflective surface 40 on the hinged display panel cover. In fact, in this second projection configuration, it is possible to remove the display panel cover 21 if desired. During operation, polarized light from the light projection device 60' is projected through the display panel 10 while it is being operated in its projection mode and video signals are driving the pixels thereof. The polarized light rays passing through the display panel are spatial intensity modulated, and thereafter focused by image projection lens 82 onto a projection display surface (e.g. wall surface) remotely situated from the computer system, as shown in Fig. 4B.

In the alternative portable light projection device 60' shown in Fig. 4B, the first housing portion 61' may be adapted to contain a number of electronic components and circuitry, namely: a pair of small audio speakers with amplification circuitry; power supply circuitry for the polarized light source; input signal ports for receiving audio signals from the computer system; and output signal ports for transmitting control signals back to the computer system in order to control the operation of the computer system during video presentations. Addition, a PCMCIA port may also be provided within the first housing portion 61' for receiving a PCMCIA-based infrared transceiver card adapted for transmitting and receiving IR-control signals between itself and a remote control device in order to control the operation of the computer system in a remote fashion in manner well known in the art.

Advantageously, portable computer system 1 has two different projection viewing modes, namely: a Projection Viewing Mode and an Enhanced Projection Viewing Mode. Notably, selection of either of these modes of image viewing is achieved without having to disassemble or mechanically reconfigure the display panel assembly of the present

invention.

Computer system 1 can be operated in its Projection Viewing Mode by performing the following simple operations: (i) moving rear panel 21 and reflective surface 40 away from Fresnel lens panel 38 of display panel assembly 10; (ii) electronically reconfiguring display panel assembly 10 into its projection viewing state of operation by applying an electric field across the optically transparent electrode surfaces of PDLC panels 25, 31, 34 and 36; and (iii) then projecting an external source of light therethrough while driving LCD panel 33 with X,Y pixel drive signals derived from the image data set written into frame buffer 12. Notably during this mode of operation, fluorescent tubes 27 and 28 are not supplied with electrical power and light from portable light projecting device 60 is used to provide backlighting for LCD panel 33, as described above.

Computer system 1 can be operated in its Enhanced Projection Viewing Mode by performing the following simple operations: (i) moving rear panel 21 and reflective surface 40 away from Fresnel lens panel 38 of the display panel assembly; (ii) electronically reconfiguring the display panel assembly into its projection viewing state of operation by applying an electric field across the optically transparent electrode surfaces of PDLC panels 25, 31, 34 and 36; (iii) supplying electrical power from supply 19 to fluorescent tubes 27 and 28; and (iv) then projecting an external source of preferably polarized light therethrough while driving LCD panel 33 with pixel drive signals derived from the image data set written into frame buffer 12.

In either of the above-described projection viewing modes, power supply 19 is used to apply an electric field across the optically transparent electrode surfaces of PDLC panels 25, 31, 34 and 36. In the

illustrative embodiment, the electric field strength applied across each of these panels is in the range of about 2 to about 20 Volts/micron. In each of these projection viewing modes, the electric field vectors of the dispersed liquid crystal molecules become physically aligned in the
5 direction of the externally applied electric field, as illustrated in Fig. 5C. In this optical state, light passes through these physically aligned liquid crystal molecules without scattering, and is ultimately intensity and spectrally modulated by LCD panel 33, on a pixel by pixel basis.

Referring now to Figs. 9 to 11A, the second illustrative
10 embodiment of the present invention is realized in the form of a portable computer system 1' capable of displaying spatially multiplexed images of 3-D objects for stereoscopic viewing thereof. In the illustrative embodiment, computer system 1' has the general system architecture shown in Fig. 2. In Fig. 9, computer system 1' is shown
15 arranged in the direct viewing configuration. In Figs. 10 and 10A, computer system 1' is shown arranged in its projection viewing configuration using a conventional overhead projector 90. Display panel assembly 10" of the third illustrative embodiment is shown in Figs. 11 and 11A, whereas display panel assembly 10'" of the fourth illustrative
20 embodiment is shown in Figs. 11 and 11B.

As can be seen from Figs. 11 and 11A, display panel assembly 10" is identical to display panel assembly 10 of the first embodiment, and the display panel assembly 10" is identical to display panel assembly 10'", with several modifications. In particular, a micropolarization panel
25 110 is directly laminated onto the front surface of LCD panel 33, and there is no Fresnel lens panel 36 affixed to PDLC panel 36. Notably, however, Fresnel lens panel 38 may be retained as in the first illustrative embodiment of the present invention. In addition, rear

panel 21' in computer system 1' is adapted for simple removal during the projection viewing mode, as shown in Fig. 9.

In portable computer system 1', the function of LCD panel 33 is to display "spatially multiplexed images (SMI)" of a 3-D object for stereoscopic viewing through a pair of polarized glasses 111 worn by viewers thereof. In general, each spatially-multiplexed image displayed from either display panel assembly 10" or 10'" is a composite pixel pattern composed of first and second spatially modulated perspective images of the 3-D object. The first spatially modulated perspective image consists of a first pixel pattern that is representative of a first perspective image of the object and spatially modulated according to a first spatial modulation pattern. The second spatially modulated perspective image consisting of a second pixel pattern that is representative of a second perspective image of the object and spatially modulated according to a second spatial modulation pattern. The second spatial modulation pattern is the logical complement of the first spatial modulation pattern.

As best shown in Figs. 11 and 11A, each spatially-multiplexed image displayed from LCD panel 33 is optically processed by micropolarization panel 110. In the illustrative embodiment, micropolarization panel 110 is realized as a optically transparent sheet directly mounted onto the display surface of LCD panel 33. Permanently formed within the optically transparent sheet are first and second optically transparent patterns. The first optically transparent pattern spatially corresponds to and is spatially aligned with the first pixel pattern in the displayed spatially-multiplexed image. The function of the first optically transparent pattern is to impart a first polarization state P1 to the radiant energy (i.e. light) associated with the first pixel

pattern. The second optically transparent pattern spatially corresponds to and is spatially aligned with the second pixel pattern in the displayed spatially-multiplexed image. The function of the second optically transparent pattern is to impart a second polarization state P2 to the
5 radiant energy (i.e. light) associated with the second pixel pattern. Importantly, the second polarization state P2 is different than the first polarization state P1 so that encoded perspective images are simultaneously displayed from polarization panel 110 with optically different polarization states. To ensure high spatial separation between
10 the displayed perspective images, the first and second optically transparent patterns each have a spatial period of less than about 50 microns.

Details regarding the manufacture of micropolarization panel 110 are disclosed in U.S. Patent No. 5,327,285. Methods and apparatus for
15 producing spatially-multiplexed images of 3-D objects are disclosed in copending U.S. Patent Nos. 5,537,144 and 5,553,203. Each of these Patents are incorporated by reference in its entirety as if set forth fully herein.

In the illustrative embodiment, optically-transparent polarizing
20 lenses 112A and 112B are mounted within the frame 112C of polarized glasses 111. During stereoscopic viewing of images displayed or projected from computer system 1', the viewer wears polarized glasses 111 as he or she would wear conventional eyeglasses. When worn on a viewer's head, polarizing lens 112A is positioned adjacent to the left eye
25 of a viewer, while the second optically transparent element 112B is positioned adjacent to the right eye of the viewer. Polarizing lens 112A is characterized by the first polarization state P1 so as to permit the left eye of the viewer to view the first spatially modulated perspective

image displayed from the micropolarization panel, while substantially preventing the left eye of the view from viewing the second spatially modulated perspective image displayed from the micropolarization panel. Polarizing lens 112B is characterized by the second polarization state P2 so as to permit the right of the view to view the second spatially modulated perspective image displayed from the micropolarization panel, while substantially preventing the right eye of the viewer from viewing the first spatially modulated perspective image displayed therefrom. This way, the viewer is capable of 3-D stereoscopic viewing of the 3-D object without "cross-viewing" from adjacent visual channels established by the stereoscopic imaging scheme.

Using the above-described spatial-multiplexing technique and display panel assembly 10' or 10'', portable computer system 1' can directly-display or project polarized spatially-multiplexed images of 3-D objects for stereoscopic viewing through light-weight polarized glasses that can be adapted to the aesthetics of the viewer.

Portable computer system 1' is configured for the projection viewing mode by first removing back panel 21' as shown in Fig. 9. Then the display portion of the housing is placed over the light projection window of the overhead projector, as shown in Fig. 10. In the illustrative embodiment, the base portion of the computer is permitted to extend vertically, by itself, or by a simple bracing device 92 that can be snapped onto the edge of the base and display portions of the computer system, as shown in Fig. 10A. In other embodiments of the present invention, the display portion of the computer system can be detached from the base thereof, and connected therewith by a standard communication cable well known in the art. In this way, the display

portion of the computer system containing display panel assembly 10" or 10'" can be placed on top of the lens panel of the overhead projector, while the heavier base portion can be conveniently located elsewhere determined the user.

5 As shown in Fig. 10A, overhead projector 90 typically contains the following components within housing 93: power supply 94, lamp 95, focusing reflector 96, focusing lens 97, and Fresnel lens 98. Image projection head 99 is supported over the light projection window 91 of the projector by way of an adjustable support comprising vertical
10 support member 100 attached to housing base 93, and horizontal support member 101 to which image head projector is connected at one end, and the vertical support member 100 is releasably connected at its other end, as shown, by slide mechanism 102. Within image projection head 99, image projection lens 104 and plane mirror 105 are mounted
15 at about 45 degrees to the projection lens 104. The geometrical optics involved in the projection viewing process are clearly described by the ray tracing shown in Fig. 10A.

When configured as shown in Figs. 10 and 10A, the computer system of the second illustrative embodiment is operated in its
20 projection viewing mode by turning on the power to lamp 95 by ON/OFF switch 106, and then selecting the Projection Viewing Mode. In any embodiment of the present invention disclosed herein, selection of a Viewing Mode command can be made by way of either a keyboard entry operation, or by selecting the command or its graphical icon in a
25 pulled-down menu supported by either the Macintosh System 7.1 operating system, the Microsoft Windows operating system, or like operating system. Alternatively, Viewing Modes can be selected by depressing designated switches accessible through the system housing.

As shown in Figs. 12 to 12D, the portable computer-based system of the present invention can be realized as a portable image display system shown incorporating any one of display panel constructions 10, 10', 10", and 10''' described above. As illustrated, portable image display system 110 includes a picture-frame shaped housing 111 having light transmission apertures 111A and 111B, through which display panel construction 10, 10', 10", or 10''' is securely mounted. Preferably, the system components shown in Fig. 2, or their functional equivalents are mounted within portable housing 111 in a conventional manner. While image display system 110 is capable of storing, and even generating frames of color image data, image display system 110 is shown in the drawings interfaced with an auxiliary computer system 112 by way of a conventional serial data communication cable 113. The function of auxiliary computer 113 is to supply color image data (e.g. SMI data) to image display system 110 for display in either its direct viewing mode, shown in Fig. 12A, or in its projection viewing mode, shown in Fig. 12B, using a slightly portable light projection device 60' of the present invention.

In Fig. 12A, image display system 110 is shown vertically supported on a desktop by way of a stand 114 that is hingedly connected to portable housing 111. Stand 114 retracts against the side walls of housing 111 during transport or storage, as shown in Fig. 12. In the direct viewing mode shown in Fig. 12A, rear housing panel 115 is snapped into place over the rear light transmission aperture so that reflective surface 40' is disposed adjacent Fresnel lens panel 38 of display panel assembly 10'. In the configuration shown in Fig. 12A, image display system 110 can be used as a backlighting panel for backlighting slides, transparencies, film structures and the like. To

enter the Backlighting Viewing Mode, LCD panel 33 is deactivated, fluorescent tubes 27 and 28 are driven, and no external electric fields are applied across PDLC panels 25, 31 34, and 36. In this mode, rear panel 115 is in place and a plane of light having a uniform intensity
5 distribution emanates from the display surface of the display panel assembly. The plane of light passes through the slide, film structure or transparency placed over the display surface, and is spatial intensity modulated and spectrally filtered thereby to display imagery graphically represented therein. In the Backlighting Viewing Mode, the
10 slide, film structure or transparency functions as a non-programmable spatial light mask placed over the backlighting panel of the present invention.

As shown in Fig. 12B, image display system 110 is configured for projection viewing by simply removing rear housing panel 115,
15 arranging portable light projection device 60' about the housing as shown, and then selecting the Projection Viewing Command, as described above. In this embodiment of the present invention, portable light projection device 60' is similar to light projection device 60 shown in Fig. 4, except for several minor modifications. First, portable light
20 projection device 60' and image display system 110 are designed so that the housings of each are adapted to interfit into a single housing of compact construction, as shown in Fig. 12. Second, first housing portion 61' is constructed similar to second housing portion 62, in that first housing portion 61' can be telescopically extended to a required height
25 by frictional engagement amongst sleeves 61A and 61B. Third, divergent polarized light rays emerge from side wall 61C of first housing portion 61' so that it can be directed through display panel assembly 10" without reflection off specularly reflective surface 40' on

the inside surface of rear housing panel 115.

Once configured as shown in Fig. 12B, portable light projection device 60' is adjusted as follows. First, the height of first housing section 61 is adjusted so that the optical axis of projection lens 78 in the first housing portion is aligned with the optical axis of Fresnel lens panel 38 in display panel assembly 10". Then, the height of optical platform 80 in the second housing portion is adjusted so that the optical axis of projection lens 82 in the second housing portion is aligned with the optical axis 117 of Fresnel lens 38. Finally, with power supplied to light source 73 and light emitting therefrom, the position of projection lens 82 along the optical axis of Fresnel lens panel 38 is adjusted so that the images formed on the display surface of by LCD panel 33 are projected onto viewing surface 89, as enlarged focused SMI images.

As shown in Figs. 13 to 13B, the portable computer-based system of the present invention can be realized as a portable pen-computing device. In the illustrative embodiment, portable pen-computing device 120 is a computer-based system having a general system architecture, as shown in Fig. 2. In addition, however, it incorporates the display/touch-screen panel assembly 121 illustrated in Fig. 13B in order to provide the same with a pen-type mode of data entry, and direct and projection modes of stereoscopically viewing 3-D objects. All of these system components are mounted within a hand-supportable housing 122 that has light transmission apertures 123A and 123B through which display/touch-screen panel assembly is supported using conventional display panel mounting techniques known in the art. A rear panel 124 snap-fits into place to cover rear light transmission aperture 123B during the direct viewing mode of operation, shown in phantom in Fig. 13. As shown in Fig. 13B, rear panel 124 supports

specularly reflective layer 40"

As illustrated in Fig. 13A, optically transparent touch-screen/display panel 121 panel comprises a number of components, namely: display panel construction 10, 10', 10" or 10''' (preferably 10");
5 a writing panel 126 having first and second surfaces 126A and 126B, respectively; a base panel 127 having first and second surfaces 127A and 127B, respectively; a plurality of optically transparent ultra-thin conductive strips 128 applied to the second surface 127A of base panel 127 in a spaced apart manner on the order of inter-pixel spacing of a
10 suitable spatial resolution; an optically transparent conductive layer 129 applied to the second surface 126B of the writing panel; and a non-conductive viscous gel 130 disposed between and electrically isolating the writing panel from the base panel. As shown, the second surface of base panel 127B is directly affixed to the display surface of LCD panel
15 33 of the display panel assembly. Writing surface 126A is exposed to the ambient environment.

The writing panel 126 is made of flexible optically transparent material, such as Mylar, which elastically deforms in response to the application of pressure on writing surface 126A by, for example, a
20 writing stylus 131 moved thereover during conventional writing operations by its user. Preferably, base panel 127 is made from an optically transparent material such as glass, although other materials may be used without significantly compromised performance. Non-conductive gel 130 contains microscopic spheres 132 made of
25 substantially non-conductive material, such as plastic, and are free to move within non-conductive gel 130 in response to the application of pressure by writing stylus 131.

As shown in Fig. 13A, each optically transparent conductive strip

128 extends parallel to every other optically transparent conductive strip and each such conductive strip is preassigned a corresponding x-coordinate value along the x-coordinate direction of the 2-D array represented along the writing surface. The y-coordinate direction in the 2-D array extends along each optically transparent conductive strip.

Whenever the stylus is moved over the writing surface, the pressure path formed therealong at each instant in time, elastically deforms the writing surface, and causes the plastic microspheres to move away from under the tip of the writing stylus. This permits a selected one of the optically transparent conductive strips 128 to momentarily establish contact with optically transparent conductive layer 129 and in response to the voltage applied across strips 128 and conductive layer 129, a small electrical current to flows therebetween. A scanning mechanism 133 is operably associated with the conductive strips and conductive layer, to cyclically determine, at each scanning interval, the x-coordinate value associated with the optically transparent conductive strip that establishes contact with the optically transparent conductive layer. The scanning mechanism also measures the small electrical current flow associated with the established electrical contact. Using this small current measure, the scanning mechanism computes the resistance associated with the circuit formed by the point of electrical contact beneath the elastically deformable writing surface. Then, using a preconstructed resistance/y-coordinate look-up table, the computed resistance measure is converted into a corresponding y coordinate value on the writing surface. For each X,Y coordinate pair assembled as described above, the processor is able to construct an image data set of the graphical pattern that was traced out on the writing surface over a specified time interval. This image data

set is stored in bit-mapped form in memory (e.g. VRAM) for subsequent display using display panel assembly 10 of the portable pen-computing device of the present invention.

Having described the method and apparatus of the present invention with reference to the above illustrative embodiments, several modifications readily come to mind

In particular, as illustrated in Figs. 14 and 14A, the light panel of the present invention can be realized without the use of polymer-dispersed liquid crystal(PDLC) technology. In this alternative embodiment, a flat display panel is constructed by affixing conventional LCD panel 33 to the front surface of light panel 140, which utilizes principles of electroluminescence, rather than disruption of total internal reflection, in order to emit light from the light panel during the light emission state thereof.

As illustrated in Figs. 14 and 14A, in particular, the flat display panel of this particular embodiment uses an electroluminescent structure having both light emissive and light transmissive modes of operation which, as will be explained above in connection with the other embodiments, are electronically selectable during direct viewing and projection viewing modes of operation, respectively.

As best illustrated in Fig. 14A, light panel 140 can be formed by depositing a thin layer of optically transparent conducting material 141, such as Indium Tin Oxide (ITO) or gold foil, about 20 to 30 Angstroms thick, on a thin optically transparent (support) panel 142, to form a first optically transparent electrode layer thereon. Thereafter, a layer of optically transparent material 143, such as the oxides of aluminum niobium tantalum, is deposited over optically transparent electrode layer 142 and panel 141. Using depositing techniques well known in

the art, a layer of electroluminescent material 144 having a high energy-band gap (e.g. greater than 73.0 electron volts) between its conduction and valence bands, such as aluminum dioxide 8.4 electron volts, is deposited over the optically transparent electrode layer 143.

5 The reason that the electroluminescent material must have such a high energy-band gap between its conduction and valence bands is that this condition ensures that the layer of electroluminescent material is optically transparent when the operating voltage (i.e. electric field) is not applied thereacross, and yet emits light when an electric field is
10 applied. Then, a layer of Indium Tin Oxide 145 is applied to a second optically transparent panel 146. Finally, optically transparent panels 141 and 146 are brought together so that electroluminescent layer 144 comes in intimate electrical contact with electrode layer 145, and electroluminescent light panel 140 of integral construction is thereby
15 formed. To the front surface of panel 146, LCD panel 33 is affixed in conventional manner. To the rear surface of panel 142, Fresnel lens panel 147 is affixed in a similar manner described above in connection with the other embodiments of the present invention.

During the direct viewing mode, an external electric field is
20 applied across electrode layers 141 and 145, and in response thereto electrons are excited to the conduction band of electroluminescent material 143 and permitted to drop to the valence band thereof, whereby photons are emitted having wavelengths in the visible portion of the electromagnetic spectrum. Details regarding the physics of the
25 electroluminescent panel hereof during its emission mode are generally described in the paper entitled "Diffraction-grating-enhanced light emission from tunnel junctions" by J. R. Kirtley, et al., published in Applied Physical Letters, Volume 37, No. 5, September 1, 1980, which is

incorporated herein by reference. In the direct viewing mode, the reflective layer adjacent Fresnel lens panel 148 functions to reflect light in the direction of LCD panel 133. In general, the intensity distribution of the light emitted from the light panel during this mode of operation is
5 substantially uniform in the x and y coordinate directions, and thus intensity compensation measures are not required.

During the projection viewing mode, no voltage (i.e. electric field) is applied across electrode layers 141 and 145, the light panel 140 is operated in its light transmission state and thus layer 141 and
10 electroluminescent layer 144 are each optically transparent and do not present significant light diffraction or scattering. In the projection viewing mode, rear panel 21' is removed away from Fresnel lens panel 147 and an external source of light, such as from device 60, is projected through the entire flat display panel assembly. In its light transmission
15 state, the projected light rays are first focused by Fresnel lens panel 147 and thereafter pass completely through the electroluminescent panel without substantial scattering or absorption of the light rays. Thereafter, the focused light rays are spatial intensity modulated by LCD panel 33 and after passing through a projection lens, as described
20 hereinabove, are ultimately projected onto a wall surface or projection screen for large field viewing.

In other embodiments of the present invention, flat display panel 140 can be mounted beneath optically transparent writing panel 126, described above, to provide a novel writing/display panel for use in a
25 variety of pen computing applications.

In yet other embodiments of the present invention, micropolarization panel 110 can be affixed to the front display surface of LCD panel 33 of writing panel 126, to permit stereoscopic viewing of

spatially multiplexed images.

As illustrated in Figs. 15, 15A and 15B, it is also possible to combine the inventive features of the portable computer system 1 and light projection device 60 disclosed herein and thereby produce a
5 lightweight, transportable computer system 1'' of integrated construction having both direct and projection viewing modes of operation. The primary advantage of this novel construction is that it avoids altogether the use of portable light projection devices as well as overhead projectors.

10 As shown in Fig. 15, the computer system 1'' is similar in all respects with the computer system 1 of the first illustrative embodiment shown in Fig. 4, except that the base portion 2'' of the housing is extended slightly in the rearward directions in order to embody the polarized light source 73, reflector lens 74, polarizing filter
15 77 and light focusing/projecting lens 78, as shown. In addition, a light transmission aperture 201 is formed in the top surface of the rear extension portion of computer system base 2'' and is selectively coverable by a hinged aperture cover 202, as shown in Fig. 15.

As shown in Figs. 15, 15A and 15B, an image projection lens
20 assembly 203 is used with computer system 1'' during its projection viewing mode of operation. As shown, image projection device 203 comprises a thin image projection lens 204 supported in a lens frame 205, from which a support stem 206 extends. Preferably, the lens frame and support stem are realized as a integral unit, fabricated from a
25 lightweight plastic. Notably, the focal lengths of image projection lens 204 and Fresnel lens panel 38 are selected so that video images are projected onto a remote projection surface (e.g. image plane 84) typically located at least 10 or more feet from the computer system.

During transport and direct viewing modes of operation, the image projection lens assembly 203 is safely housed within a vacant storage compartment 207 formed in the central lower portion of the computer system base, as shown in Figs. 15 and 15A. In general, the physical dimensions of storage compartment 207 are slightly greater than the physical dimensions of the projection lens assembly. An access opening 207A is formed in the front of computer system base to provide access to storage compartment 207, as shown in Fig. 15A. To store the projection lens assembly, all that is necessarily is to slide the stem portion of the assembly into the access opening 207A, as shown in Fig. 15A, and push it thereinto until it is completely accommodated by the walls of the storage compartment. To remove the projection lens assembly, the reverse operations are performed. As shown in Fig. 15B, the projection lens is mounted along the projection axis of the Fresnel lens panel 38 by inserting the end of stem portion 206 into stem mounting slot 208 formed in the edge of the computer system base.

During the projection viewing mode of operation, the computer system 1'' is configured as shown in Fig. 15. In this configuration, aperture cover 202 is arranged in its open configuration and projection lens 204 is mounted along the projection axis of the Fresnel lens panel 38. The computer system is induced in its projection viewing mode and video signals are provided to the pixel drivers of the display panel assembly. As polarized light rays are produced from internal light source 73, they are reflected off light reflective surface 40 on rear housing panel 21 and projected through the display panel assembly 10. Simultaneously, the polarized light rays are spatial intensity modulated in accordance with the video signals driving the pixel drivers and focused by Fresnel lens panel 38 onto the principal plane of image

projection lens 205 supported along the projection axis thereof. The focused color images formed at the principal plane of projection lens 205 are then projected onto a remote projection display surface located at a predetermined distance away from the computer system. The
5 projection display surface may be a wall surface, a projection display screen or like surface. Alternatively, image projection lens 205 may be adapted with an image focusing adjustment mechanism 210 that permits projection lens 205 to be simply translated along the projection axis of Fresnel lens 38 in order to adjust the focal distance, and thus the
10 projection plane onto which projected color images are to be projected by computer system 1'' in its projection viewing mode. This feature permits the computer system 1'' to project in-focus color images onto electrically passive surfaces located at a broad range of distances from the display panel thereof.

15 During the direct viewing mode, the computer system 1'' is reconfigured so that the image projection lens assembly is dismounted and stored within the storage compartment 207. The display panel assembly 10 is induced in its direct viewing mode. The viewer is permitted to view displayed imagery directly from the display surface
20 of the display panel in a conventional manner. Preferably, the computer system 1'' is adapted for multi-media presentations, combining both video and sound in both direct and projection viewing modes of operation.

In Figs. 16 and 17, two alternative embodiments of the
25 transportable image projection system hereof are schematically illustrated. Like the other illustrative embodiments disclosed herein, these transportable image projection systems employ the electro-optical light panel of the present invention to realize a transportable system

having both direct and projection viewing modes of operation. During the direct viewing mode of operation, spatially-multiplexed images (SMIs) can be displayed on the surface of the electro-optical light panel of the system for use in stereoscopic 3-D viewing through a pair of polarization eyeglasses, such as polarizing eyeglasses 111 shown in Figs. 12A and 12B. During its projection viewing mode of operation, SMIs can be projected onto a remotely situated projection viewing screen 89 for stereoscopic 3-D viewing through polarization eyeglasses 111. As will become apparent hereinafter, the image display systems of these alternative embodiments can be used in virtually any environment where direct or projection viewing is desired or required.

As shown in Fig. 16, image display system 300 comprises a transportable housing 301 having a light transmission aperture 302 and an interior volume 303 within which the various optical and electro-optical components of system are configured to carry out the objects of the present invention. In this illustrative embodiment, any one of the electro-optical panel assemblies shown in Figs. 5A, 5B, 11A, 11B, 12C and 12D (hereinafter collectively denoted by "10") is mounted within or adjacent light transmission aperture 302 by way of conventional panel mounting techniques. As described in great detail hereinabove, each of one there electro-optical panel assemblies has a plurality of PDLC light diffusing panels, which have light-scattering and light non-scattering states of operation selectable under electronic control.

As shown in Fig. 16, a light projection system 304 is mounted behind the electro-optical panel assembly 10, within the transportable housing. Light projection system 304 can be realized by arranging, for example, optical elements 73, 74, 77 and 78 as shown in Fig. 4B. The image display system of Fig. 16 also includes a system controller 305 for

producing control signals used to control light projection system 304 and electro-optical display panel 10. Stereoscopic 3-D viewing capabilities are provided to the image display system of Fig. 16 by affixing a retardation-based micropolarization panel 110B to the surface of the LCD panel, and providing viewers polarizing eyeglasses 11 through which to view micropolarized SMIs displayed in either the direct or projection viewing mode. The selection of the focal distances for projection lens 78 and Fresnel lens 38 will be made by considering the functions that must be achieved during the direct and projection viewing modes when using the electro-optical display panel 10, or variation thereof.

When the image display system of Fig. 16 is operated in its direct viewing mode, light projection system 304 focuses polarized light rays onto the electro-optical panel assembly 10 while the PDLC light diffusing panels thereof diffusely scatter these polarized light rays and the LCD panel 33 spatial intensity modulate the diffusely scattered light rays. 10. These functions can be achieved by realizing the following conditions. During the direct viewing mode, PDLC light diffusing panels of electro-optical panel assembly 10 are operated in their light non-scattering state of operation. The focal distance of projection lens 78 is selected to equal the distance between the principal lens of projection lens 78 and the principal plane of Fresnel lens 38. Also, the focal distance of Fresnel lens 38 is selected to be relatively long in comparison with the focal distance of projection lens 78 so that Fresnel lens 38 has little effect on the light rays being directly viewed by a viewer positioned closely adjacent the display panel during the direct viewing mode.

When the image display system of Fig. 16 is operated in its

projection viewing mode, the projection lens within light projection system 304 cooperates with the Fresnel lens panel within electro-optical panel assembly 10 to focus polarized light rays onto projection display surface 89. During this mode of operation, the PDLC light diffusing panels within electro-optical panel assembly 10 are operated in their light transmissive, non-scattering mode so that they transmit, without scattering, projected light rays while the LCD panel of electro-optical panel assembly 10 spatial intensity modulates the same before being projected onto projection display surface 89. In order to correctly view images displayed on the projection display screen during the projection viewing mode, image inverter 306 is used to process the pixel drive signals provided to the LCD panel during the spatial intensity modulation (i.e. image formation) process so that viewers may correctly view imagery being display on projection screen 89. Image inverter 306 can be readily realized using computer software or logic circuitry in a manner known in the art.

The stereoscopic image display system shown in Fig. 17 can be obtained by modifying the image display system of Fig. 16 in a number of respects. As will be apparent below, the resulting image display system is characterized by a simpler, more efficient construction.

As shown in Fig. 17, image display system 300' comprises: housing 301 and light transmission aperture 302; a simplified electro-optical light panel assembly 10'''' consisting of only plexiglass support substrate 25', PDLC light diffusing panel 31, and micropolarization panel 110B shown in Fig. 11B, assembled together in the named order to form an integral display panel structure having a projection axis normal to its display surface; an image projector 307 (e.g. the Model CPJ-100 LCD Projector from the SONY Corporation, of Tokyo, Japan, or a state-of-the

art photo slide-film projector) mounted within the housing along the projection axis of electro-optical light panel assembly 10''''; a variable focal-distance projection lens system 308 mounted within the housing between the image projector 307 and electro-optical light panel assembly 10''''', for projecting focused image to a first focal distance $f(dv)$ in the direct viewing mode, and for projecting focused image to a second, substantially longer focal distance $f(pv)$ in the projection viewing mode; an image inverter 309 (e.g. VCD drive signal processor for the CPJ-100 LCD Projector, and image inversion optics for the state-of-the-art photoslide-film projector) for inverting projected images so that they are correctly viewed from left-to-right and right-to-left on projection display screen 89; and a microprocessor-realized system controller 305' for producing control signals that are used to control the state of operation of the image projector 307, the variable focal-distance projection lens system 308, the electro-optical light panel assembly 10'''' and image inverter 309 during direct and projection modes of operation. Stereoscopic 3-D viewing capabilities are provided to the image display system of Fig. 17 by affixing a retardation-based micropolarization panel 110B to the surface of the LCD panel within the CPJ-100 LCD Projector, or to the surface of film-slides to be viewed, depending on which embodiment of the image projector is being realized, and providing viewers polarizing eyeglasses 111 through which micropolarized SMIs can be viewed in either the direct or projection mode.

25 When the image display system of Fig. 17 is operated in its direct viewing mode, the electrically-addressable LCD panel within the CPJ-100 LCD Projector, or the film structure of film slide being viewed, spatial intensity modulates projected light rays, while variable-focus

projection lens system 308 focuses the spatial-intensity modulated light rays onto the PDLC light diffusing panel 31 of electro-optical panel assembly 10'''' which diffusely scatters such rays to form a focused image thereupon for directly viewing by a nearby viewer. Then when
5 the image display system of Fig. 17 is operated in its projection viewing mode, the electrically-addressable LCD panel within the CPJ-100 LCD Projector, or the film structure of film slide being viewed, spatial intensity modulates light rays projected towards the electro-optical light panel assembly 10'''', and variable-focus projection lens system 308
10 focuses the spatial-intensity modulated light rays onto projection display surface 89, while the PDLC light diffusing panel of electro-optical light panel assembly 10'''' allows projected light rays to be transmitted therethrough with minimal light scattering. These functions are achieved as follows. In the direct viewing mode, the system
15 controller 305' sets the focal distance of variable-focus projection lens system 308 to equal the distance between the principal plane of projection lens system and the principal plane of the PDLC light diffusing panel within electro-optical light panel assembly 10'''', while operating the PDLC light diffusing panel in its light scattering state. In
20 the projection viewing mode, the system controller 305' sets the focal distance of variable-focus projection lens system 308 to equal the distance between the principal plane of projection lens system 308 and projection display surface 89, while operating the PDLC light diffusing panel of electro-optical light panel assembly 10'''' in its light non-
25 scattering state and operating image inverter 309 so that projected images are correctly displayed (i.e. from left-to-right and vice versa) on projection display surface 89.

For purposes of clarity, the various information storage and

processing facilities shown in Fig. 2 have not been explicitly shown in Figs. 16 and 17. It is understood, however, that such functionalities can and will typically be embodied within image display systems 300 and 300' described in great detail above.

5 The modifications to the various aspects of the present invention described above are merely exemplary. It is understood that other modifications to the illustrative embodiments will readily occur to persons with ordinary skill in the art. All such modifications and variations are deemed to be within the scope and spirit of the present
10 invention as defined by the accompanying Claims to Invention.

CLAIMS TO INVENTION

1. An image display system having direct and projection viewing
5 modes, comprising;
light producing means for producing light during said direct and
projection viewing modes;
an electro-optical panel having a light scattering state in which
light being transmitted therethrough is scattered in a diffusive manner,
10 and a light transmission state in which light being transmitted
therethrough is transmitted without substantial scattering;
a light modulation structure for modulating the spatial intensity of
light produced from said light producing means during said direct
viewing mode and during said projection viewing mode; and
15 state selection means for selecting the light scattering state of said
electro-optical panel during said direct viewing mode, and the light
transmission state of said electro-optical panel during said projection
viewing mode;
wherein during said direct viewing mode, light produced from
20 said light producing means is scattered by said electro-optical panel and
spatial intensity modulated by said light modulation structure to form a
first image for direct viewing; and
wherein during said projection viewing mode, light produced from
said light producing means is transmitted through said electro-optical
25 panel without substantial scattering and spatial intensity modulated by
said light modulation structure to form a second image for projection
onto a projection display surface for projection viewing.
2. The image display system of claim 1, wherein said light modulation

structure is an electrically-addressable spatial light modulation panel that is mounted closely adjacent said electro-optical panel.

3. The image display system of claim 2, wherein said electro-optical
5 panel is disposed between said light source and said electrically-addressable spatial light modulation panel.

4. The image display system of claim 3, wherein said electro-optical
panel and said electrically-addressable spatial light modulation panel
10 are mounted together to form an integrated display panel assembly.

5. The image display system of claim 4, which further comprises a
micropolarization panel mounted onto said electrically-addressable
spatial light modulation panel for micropolarizing spatially multiplexed
15 images displayed in either said direct or projection viewing mode.

6. The image display system of claim 2, wherein said electro-optical
panel comprises a polymer-dispersed liquid crystal (PDLC) panel having
optically transparent electrode surfaces.
20

7. The image display system of claim 2, which further comprises a thin
light focusing panel disposed closely adjacent to said electrically-
addressable spatial light modulation panel, for focusing spatial intensity
modulated light onto said projection display surface located at a
25 predetermined focal plane during said projection viewing mode.

8. The image display system of claim 7, wherein said thin light focusing
panel is an optical element selected from the group consisting of a
holographic lens panel and a Fresnel lens panel.
30

9. The image display system of claim 2, wherein said electrically-addressable spatial light modulation panel comprises an active-matrix LCD panel.

5 10. The image display system of claim 9, wherein light producing means produces light having a polarization state which is employed by said active-matrix LCD panel.

10 11. The image display system of claim 1, wherein said light modulation structure is disposed near said light producing means.

12. The image display system of claim 11, wherein said light modulation structure is an electrically-addressable spatial light modulation panel disposed between said said light source and said
15 electro-optical panel.

13. The image display system of claim 11, which further comprises a variable-focus projection lens system disposed near said light modulation structure,

20 said variable-focus projection lens system having at least a first focal distance for focusing spatial intensity modulated light from said light modulation panel onto said electro-optical panel during said projection viewing mode, and a second focal distance for projecting spatial intensity modulated light from said light modulation structure
25 through said light diffusing panel, onto said projection display surface located at said second focal distance, during said projection viewing mode.

14. The image display system of claim 12, which further comprises a

micropolarization panel mounted onto said electrically-addressable spatial light modulation panel for micropolarizing spatially multiplexed images displayed in either said direct or projection viewing mode.

5 15. The image display system of claim 14, wherein said electrically-addressable spatial light modulation panel and said micropolarization panel are mounted together to form an integrated electro-optical structure.

10 16. The image display system of claim 13, wherein said electro-optical panel comprises a polymer-dispersed liquid crystal (PDLC) panel having optically transparent electrode surfaces.

15 17. The image display system of claim 12, wherein said electrically-addressable spatial light modulation panel comprises an active-matrix LCD panel.

20 18. The image display system of claim 17, wherein light producing means produces light having a polarization state which is employed by said active-matrix LCD panel.

25 19. The image display system of claim 1, which further comprises a transportable housing having an interior volume within which the components of the system are enclosed, and a light transmission aperture through which spatial intensity modulated light can be transmitted during said direct and projection viewing modes.

20. The image display system of claim 11, wherein said light modulation structure is a slide-film structure to be viewed.

21. An image display system having direct and projection viewing modes,

wherein during said direct viewing mode, light produced from a light producing means is scattered by an electro-optical panel and spatial intensity modulated by a light modulation structure to form a first image for direct viewing; and

wherein during said projection viewing mode, light produced from said light producing means is transmitted through said electro-optical panel without substantial scattering and spatial intensity modulated by said light modulation structure to form a second image for projection onto a projection display surface for projection viewing.

22. The image display system of claim 21, wherein said light modulation structure is an electrically-addressable spatial light modulation panel that is mounted closely adjacent said electro-optical panel.

23. The image display system of claim 22, wherein said electro-optical panel is disposed between said light source and said electrically-addressable spatial light modulation panel.

24. The image display system of claim 23, wherein said electro-optical panel and said electrically-addressable spatial light modulation panel are mounted together to form an integrated display panel assembly.

25. The image display system of claim 24, which further comprises a micropolarization panel mounted onto said electrically-addressable spatial light modulation panel for micropolarizing spatially multiplexed images displayed in either said direct or projection viewing mode.

26. The image display system of claim 22, wherein said electro-optical panel comprises a polymer-dispersed liquid crystal (PDLC) panel having optically transparent electrode surfaces.

5

27. The image display system of claim 22, which further comprises a thin light focusing panel disposed closely adjacent to said electrically-addressable spatial light modulation panel, for focusing spatial intensity modulated light onto said projection display surface located at a predetermined focal plane during said projection viewing mode.

10

28. The image display system of claim 27, wherein said thin light focusing panel is an optical element selected from the group consisting of a holographic lens panel and a Fresnel lens panel.

15

29. The image display system of claim 22, wherein said electrically-addressable spatial light modulation panel comprises an active-matrix LCD panel.

20

30. The image display system of claim 29, wherein light producing means produces light having a polarization state which is employed by said active-matrix LCD panel.

25

31. The image display system of claim 21, wherein said light modulation structure is disposed near said light producing means.

32. The image display system of claim 31, wherein said light modulation structure is an electrically-addressable spatial light modulation panel disposed between said said light source and said

30

electro-optical panel.

33. The image display system of claim 31, which further comprises a variable-focus projection lens system disposed near said light

5 modulation structure,

said variable-focus projection lens system having at least a first focal distance for focusing spatial intensity modulated light from said light modulation panel onto said electro-optical panel during said projection viewing mode, and a second focal distance for projecting

10 spatial intensity modulated light from said light modulation structure through said light diffusing panel, onto said projection display surface located at said second focal distance, during said projection viewing mode.

15 34. The image display system of claim 32, which further comprises a micropolarization panel mounted onto said electrically-addressable spatial light modulation panel for micropolarizing spatially multiplexed images displayed in either said direct or projection viewing mode.

20 35. The image display system of claim 34, wherein said electrically-addressable spatial light modulation panel and said micropolarization panel are mounted together to form an integrated electro-optical structure.

25 36. The image display system of claim 33, wherein said electro-optical panel comprises a polymer-dispersed liquid crystal (PDLC) panel having optically transparent electrode surfaces.

37. The image display system of claim 32, wherein said electrically-

addressable spatial light modulation panel comprises an active-matrix LCD panel.

38. The image display system of claim 37, wherein light producing
5 means produces light having a polarization state which is employed by said active-matrix LCD panel.

39. The image display system of claim 21, which further comprises a
10 transportable housing having an interior volume within which the components of the system are enclosed, and a light transmission aperture through which spatial intensity modulated light can be transmitted during said direct and projection viewing modes.

40. The image display system of claim 31, wherein said light
15 modulation structure is a slide-film structure to be viewed.

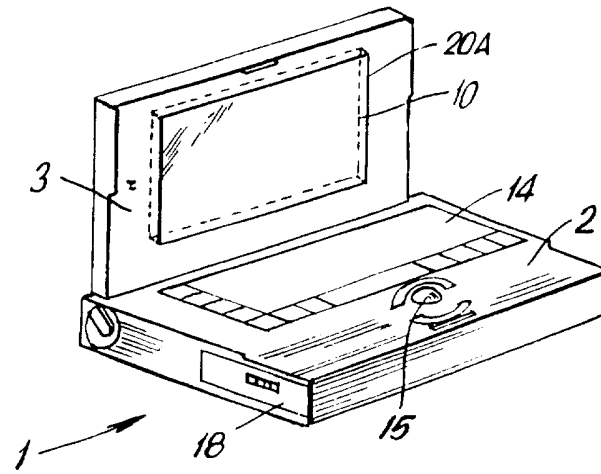

FIG. 1

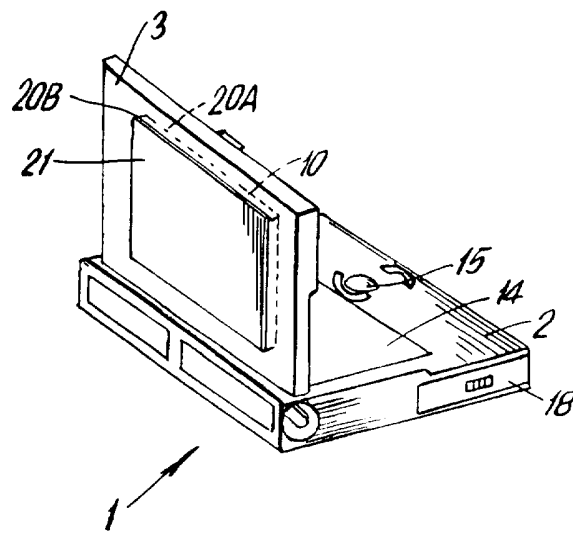

FIG. 1A

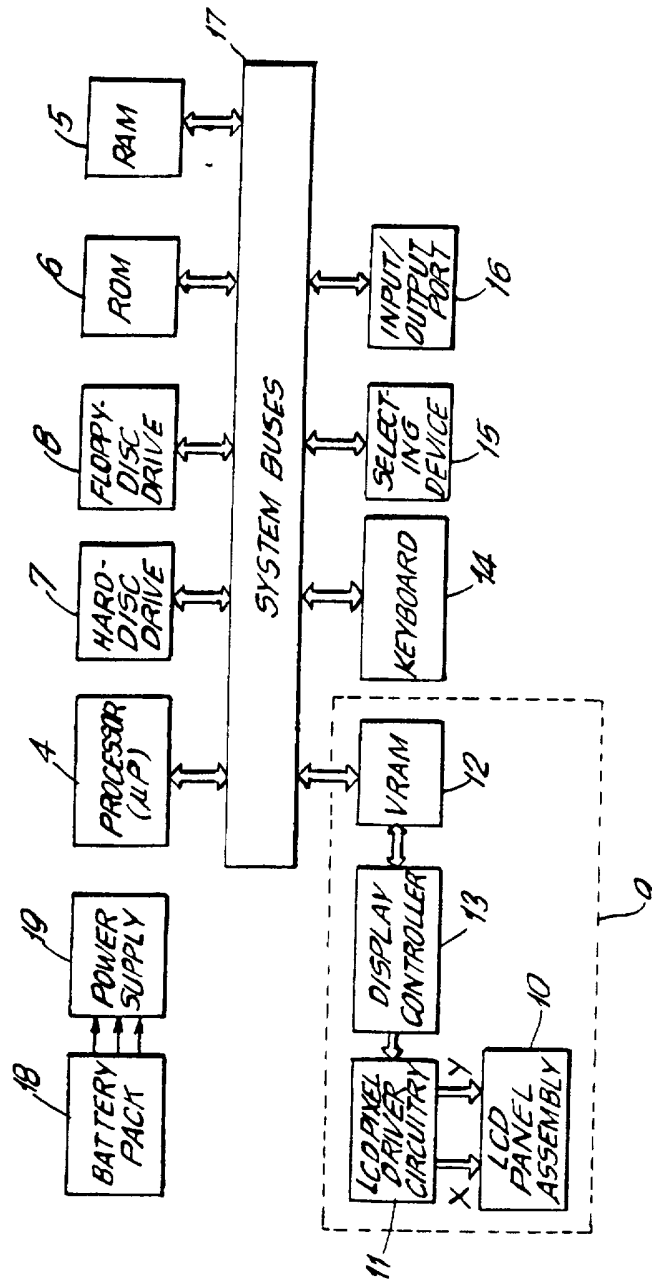

FIG. 2

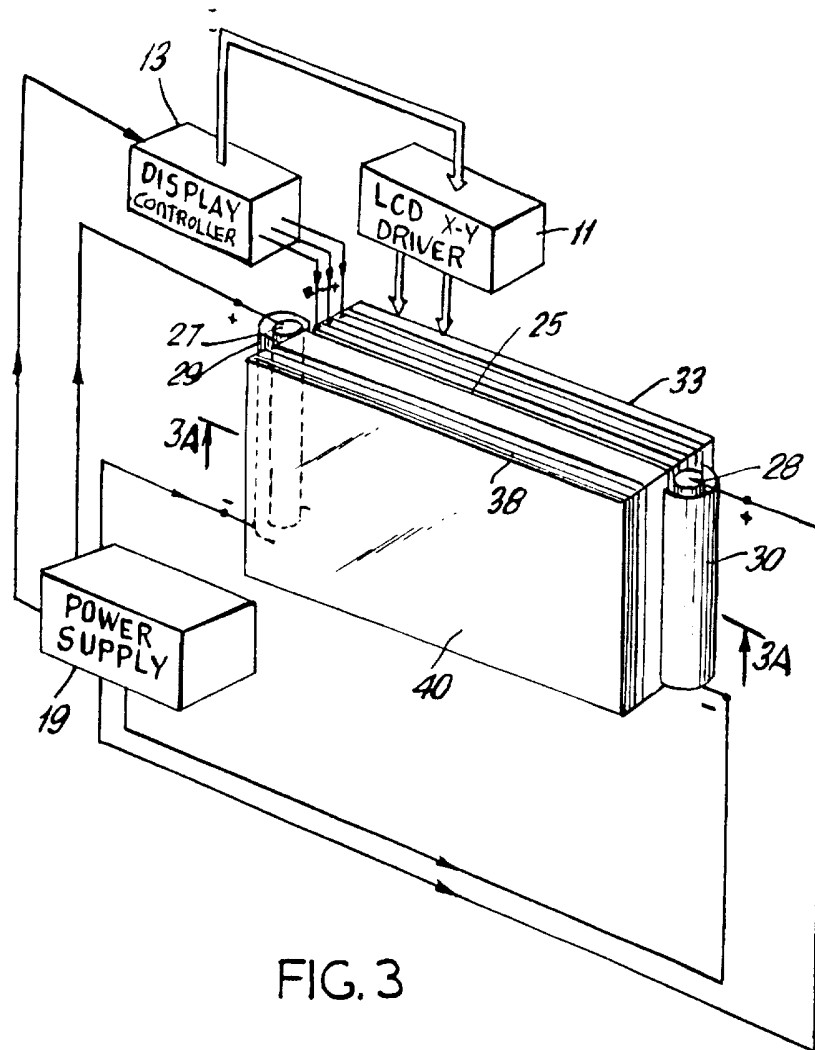

FIG. 3

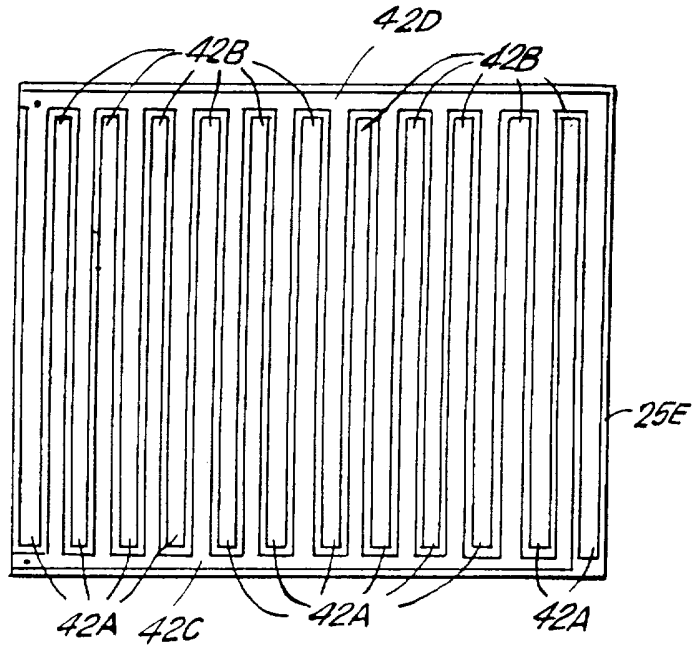

FIG. 3D

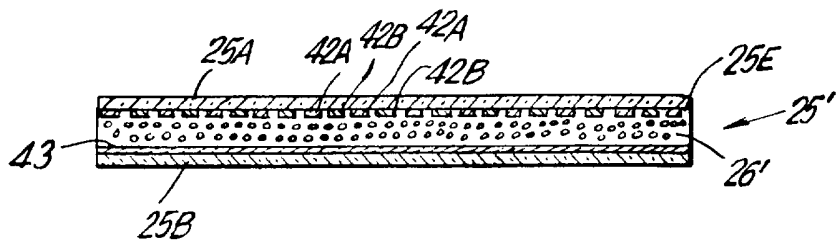

FIG. 3E

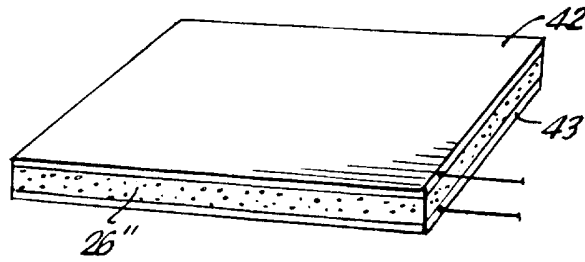

FIG. 3F

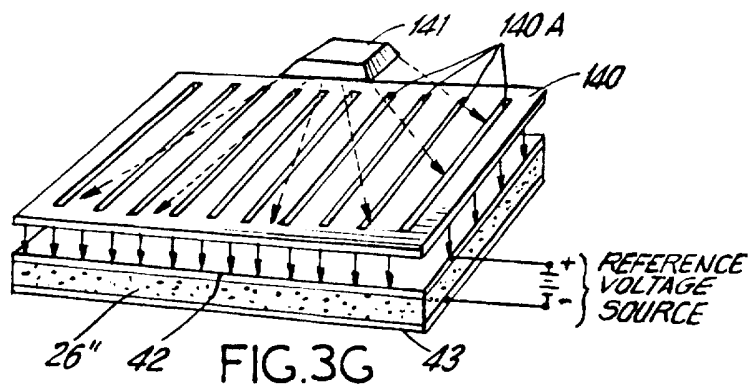

FIG. 3G

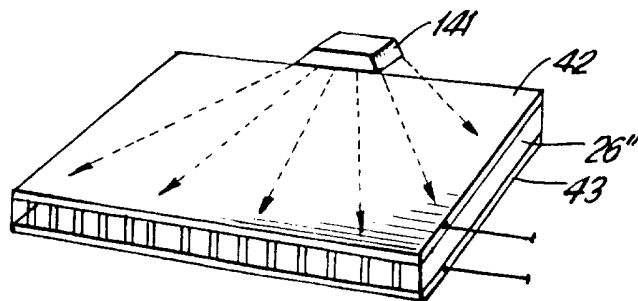
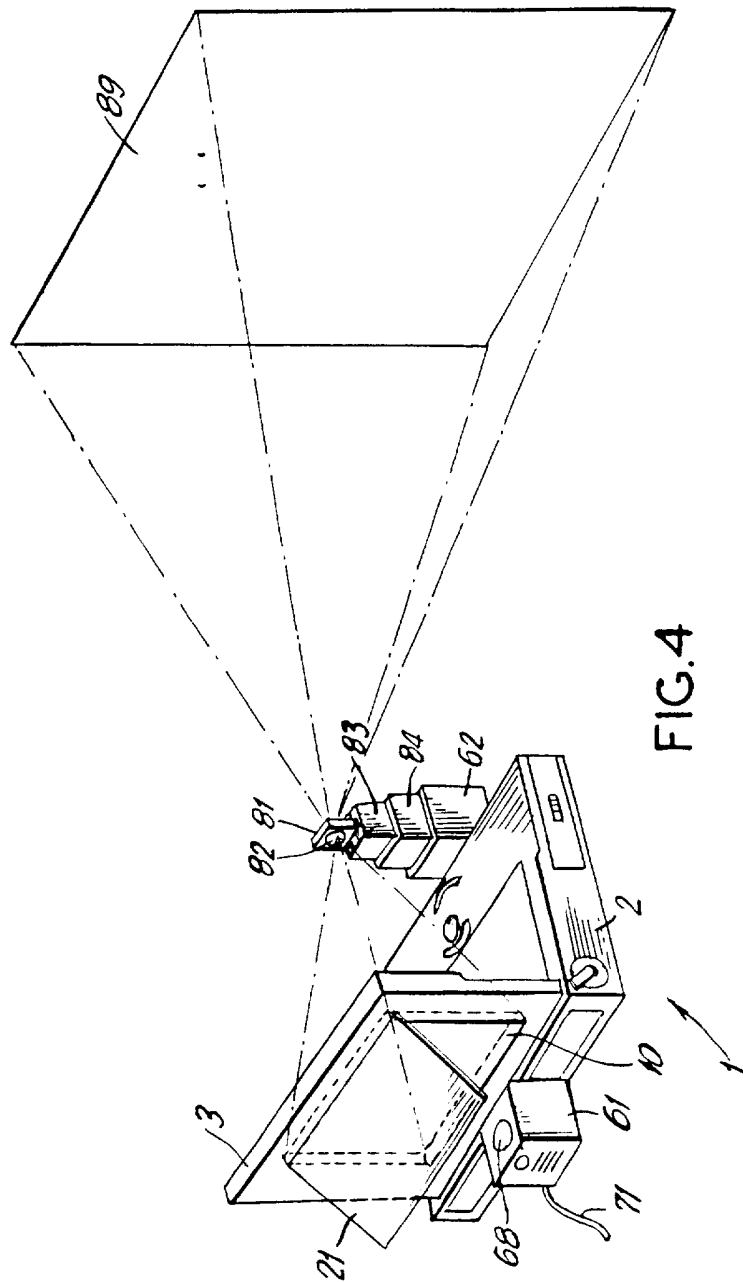

FIG. 3H



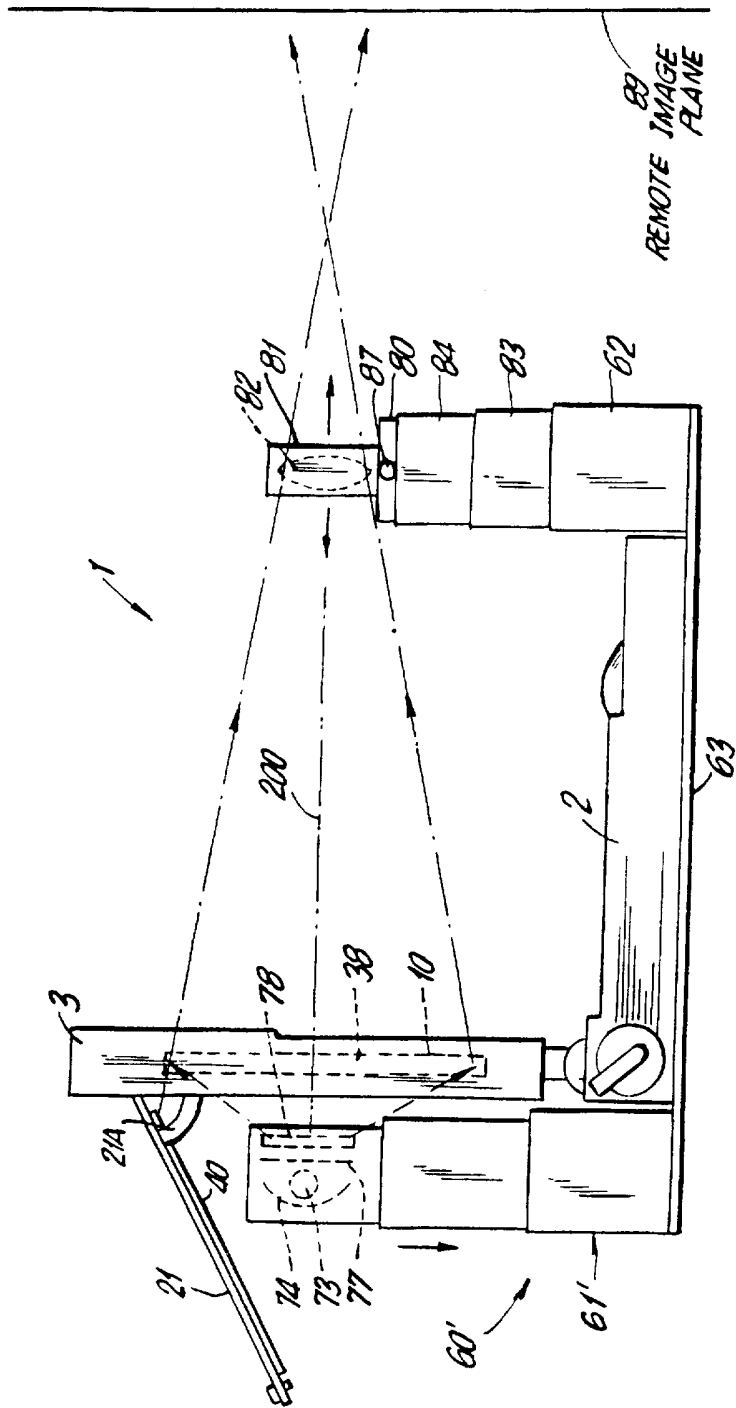

FIG. 4B

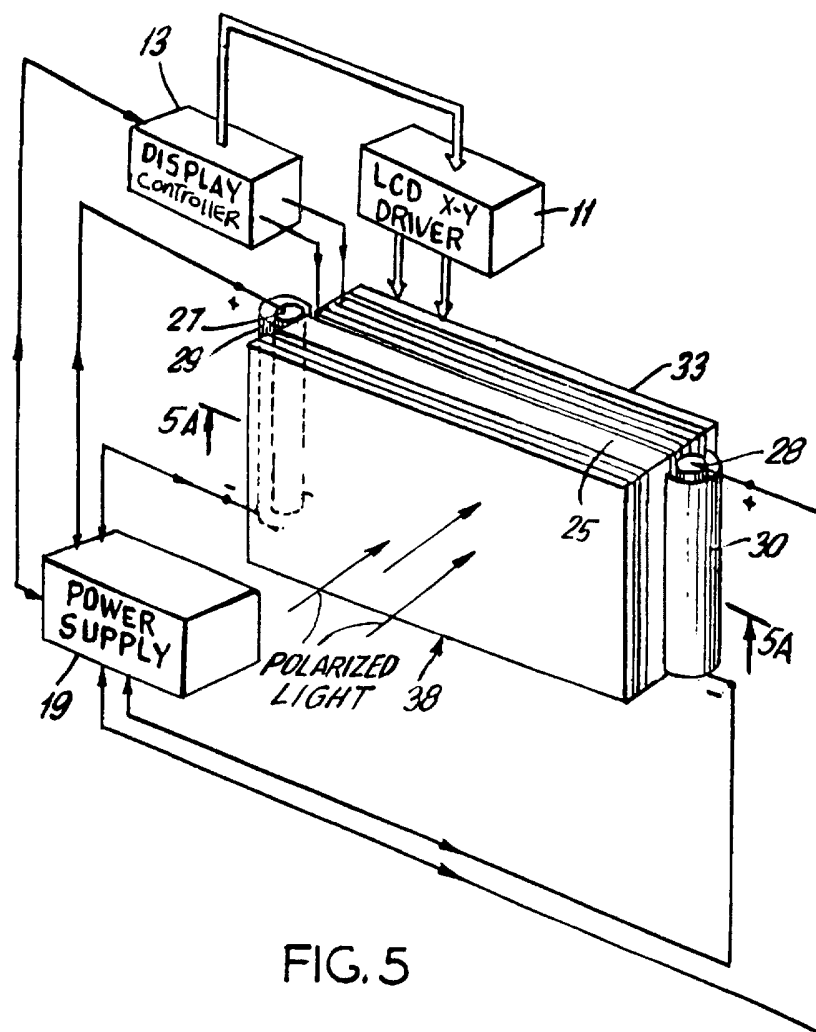
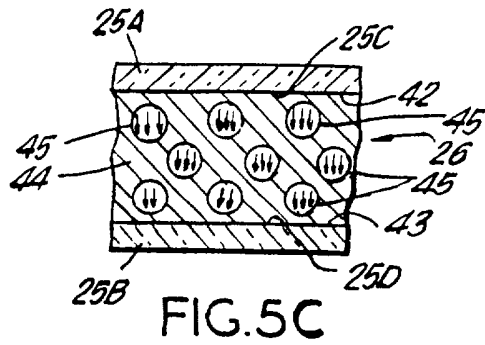
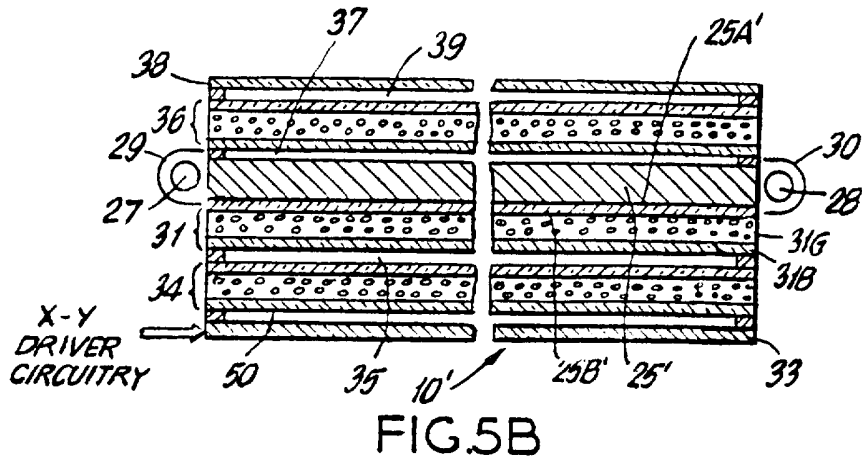
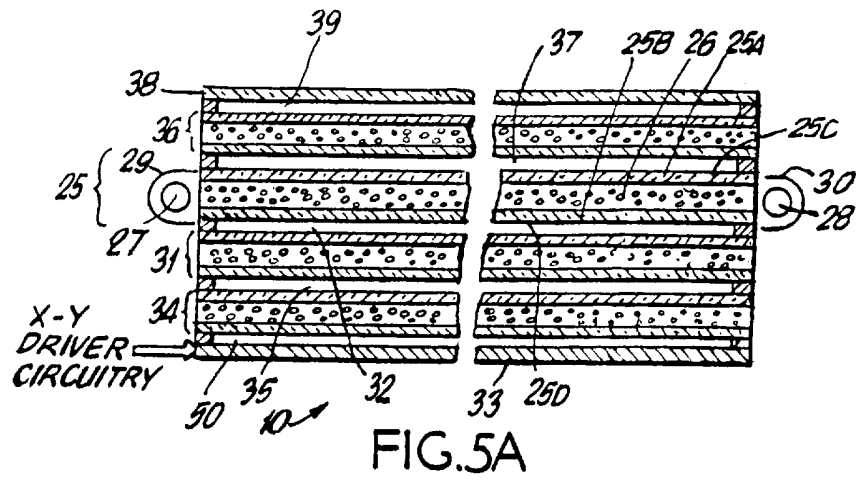

FIG. 5



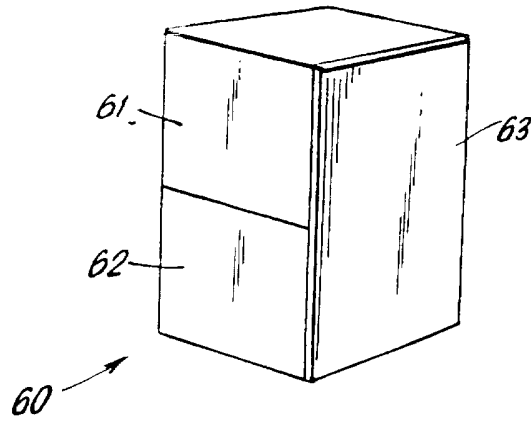

FIG. 6A

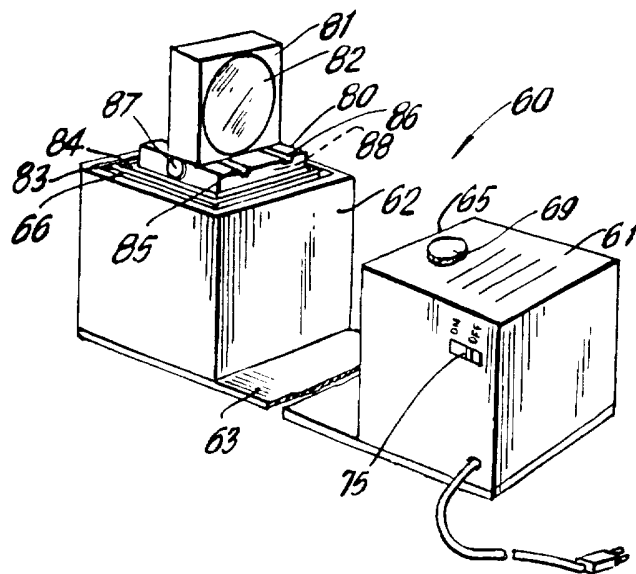

FIG. 6B

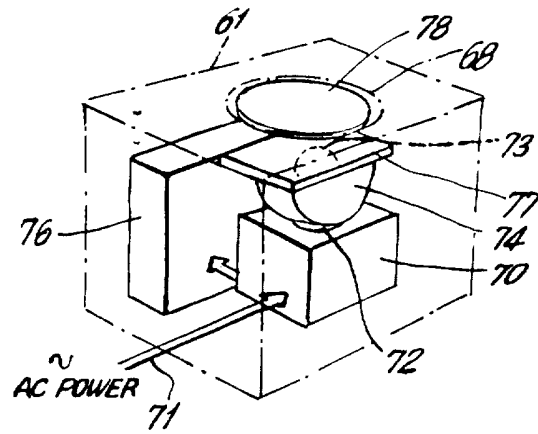

FIG. 7

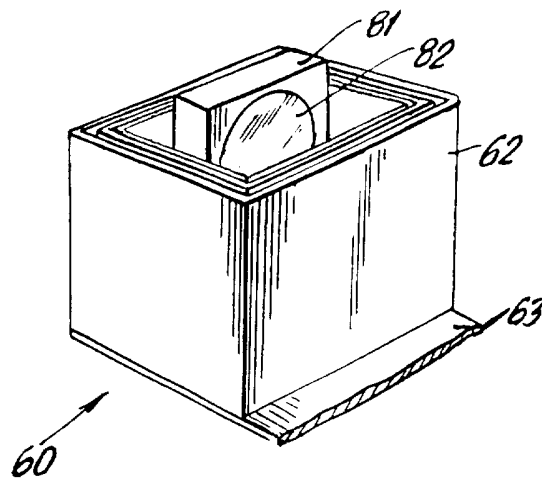

FIG. 8

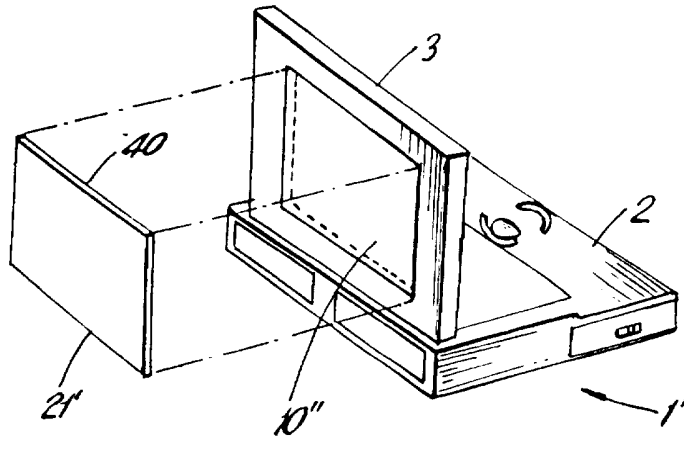

FIG. 9

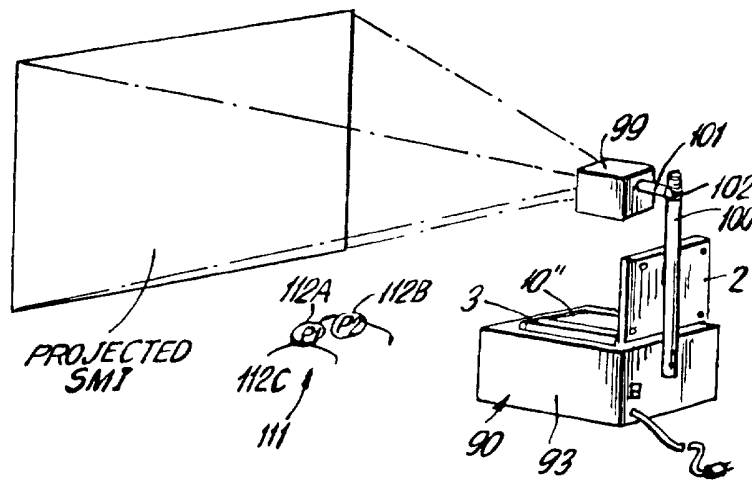

FIG. 10

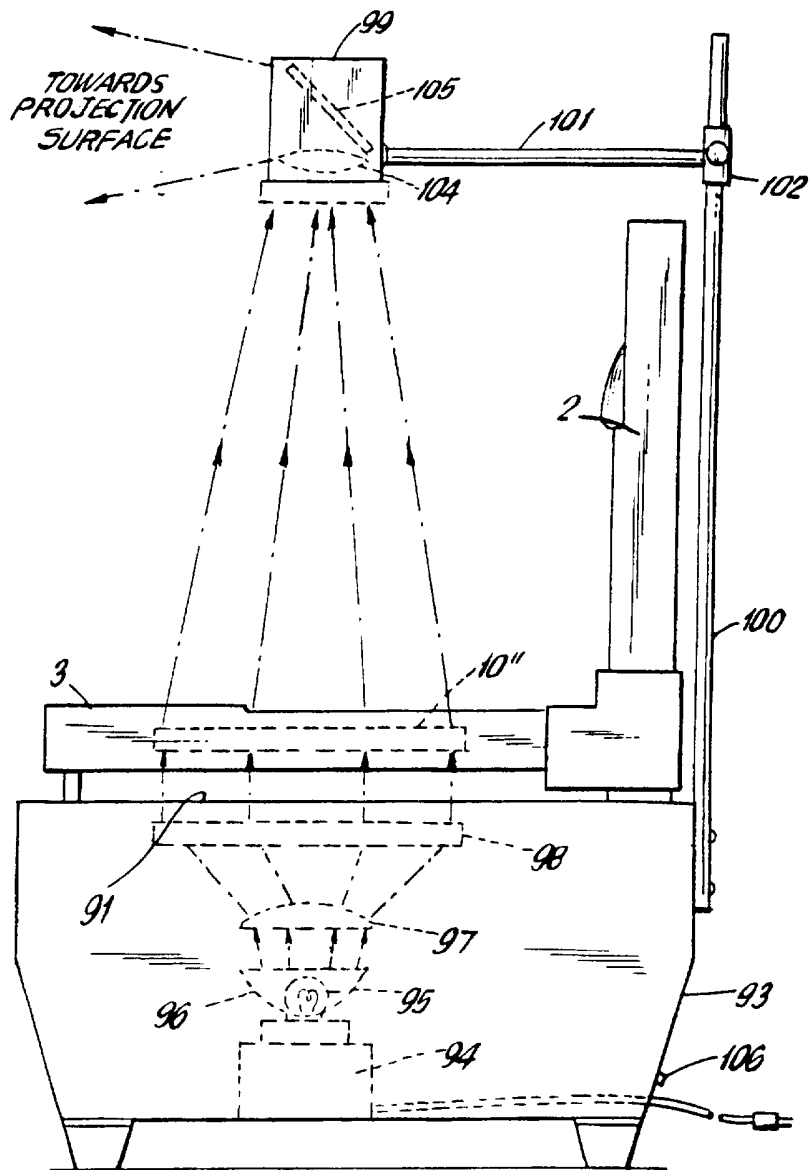
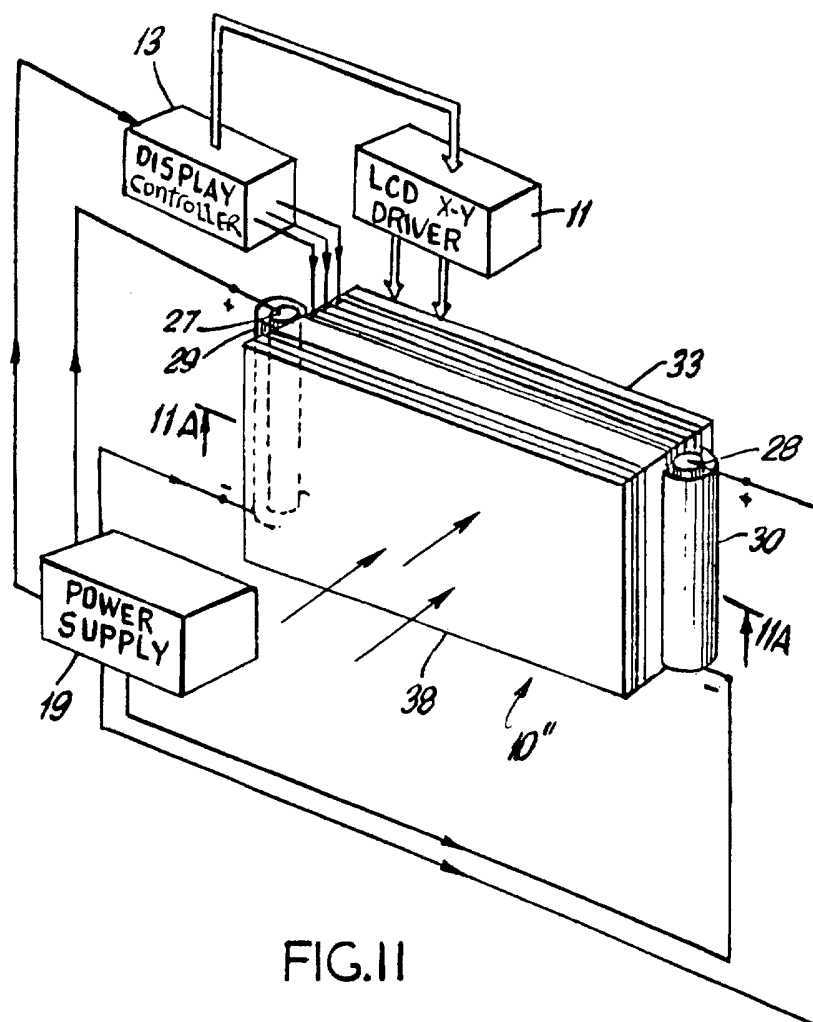
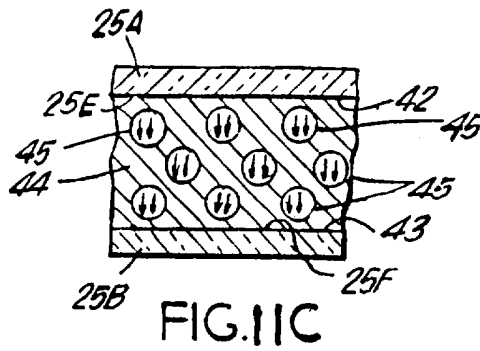
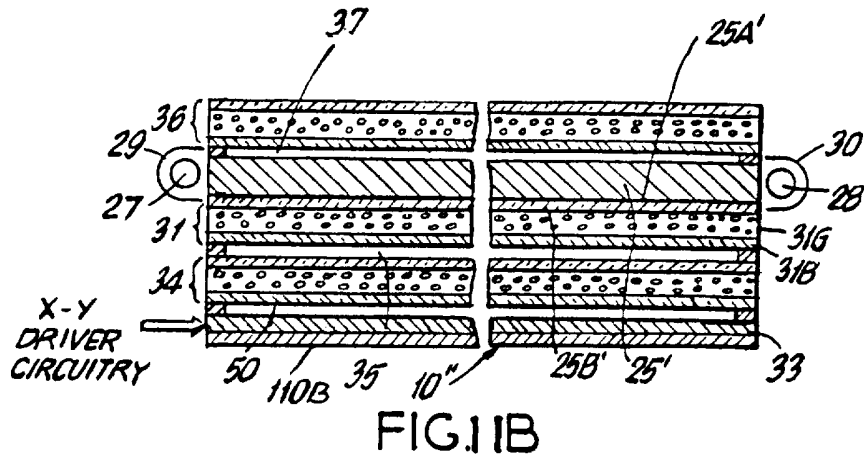
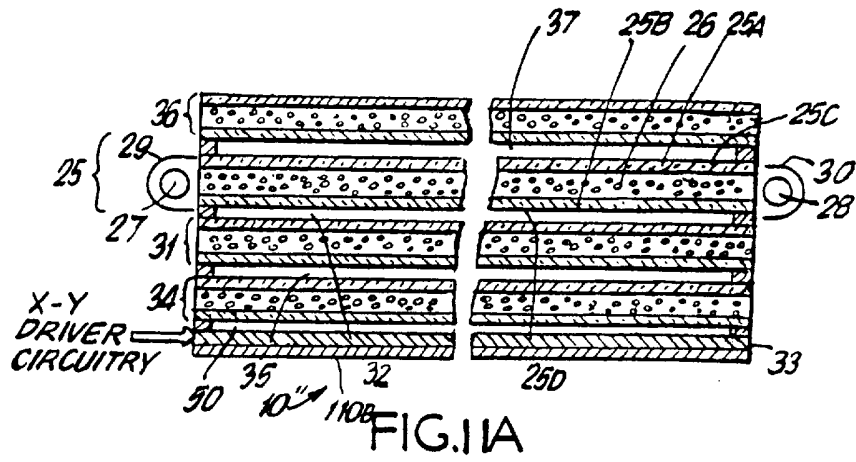
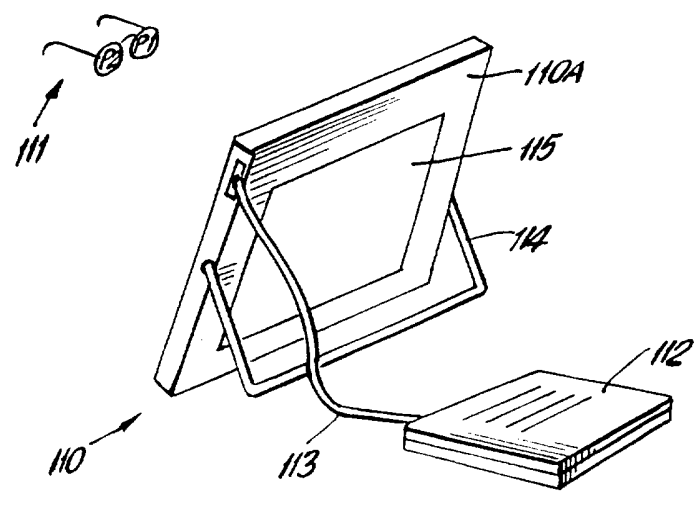
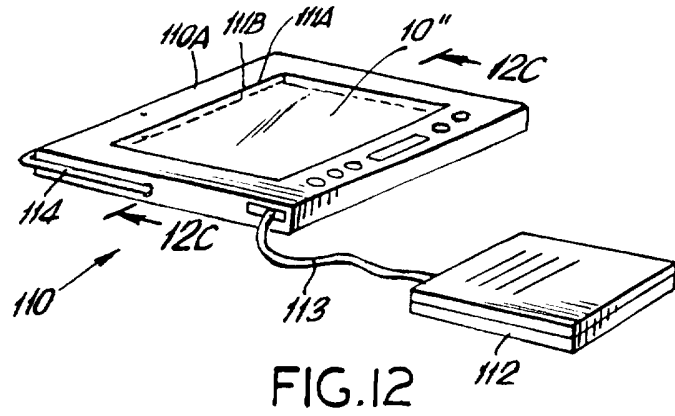

FIG.10A







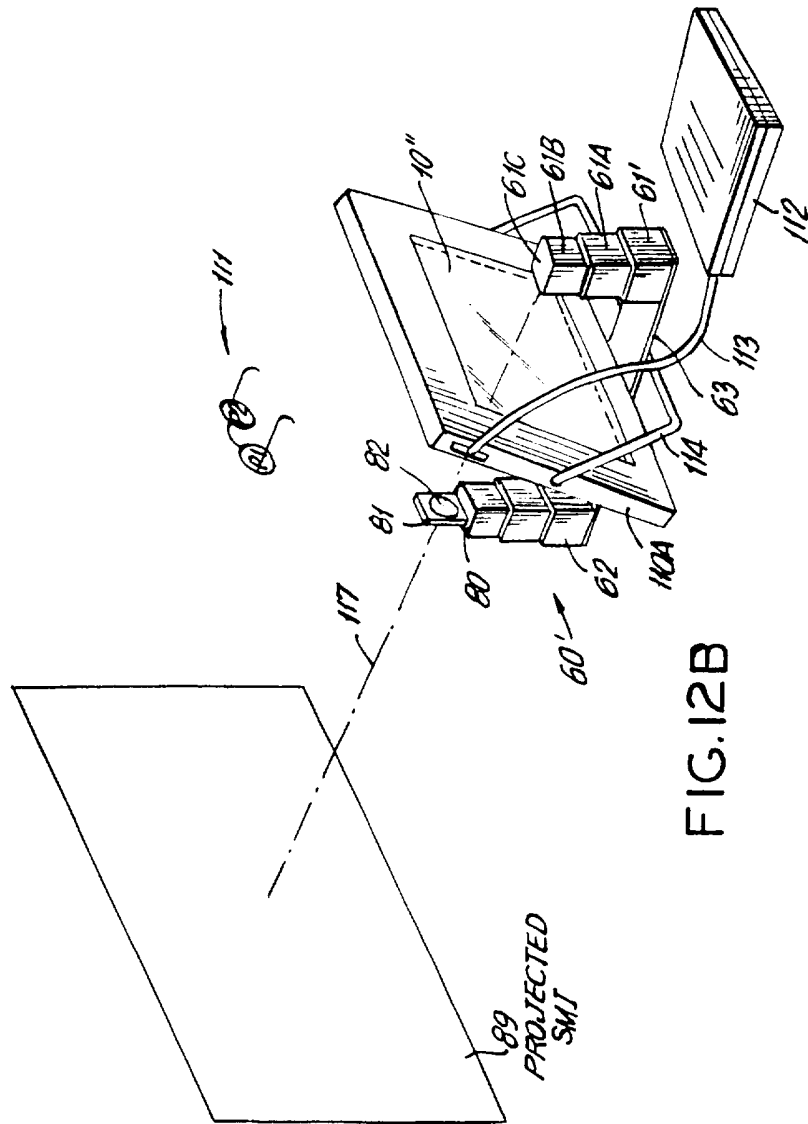
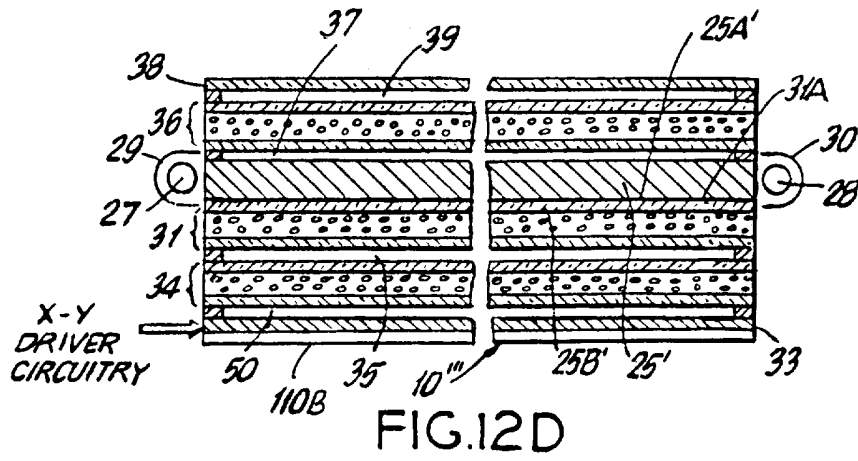
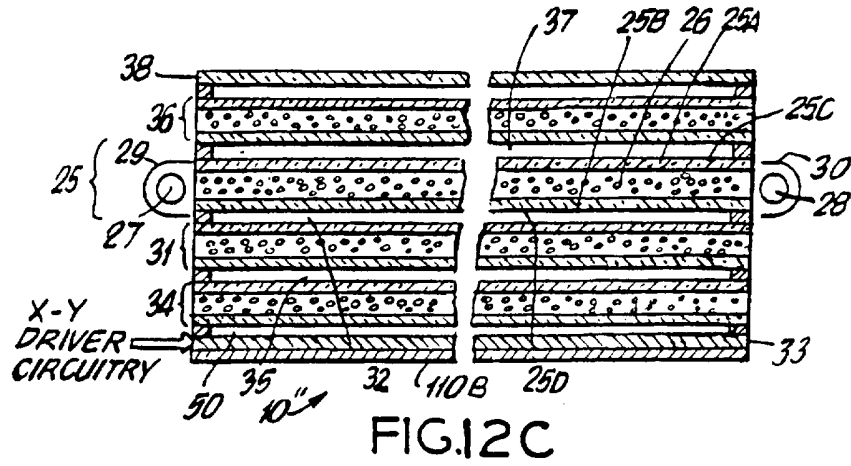

FIG. 12B



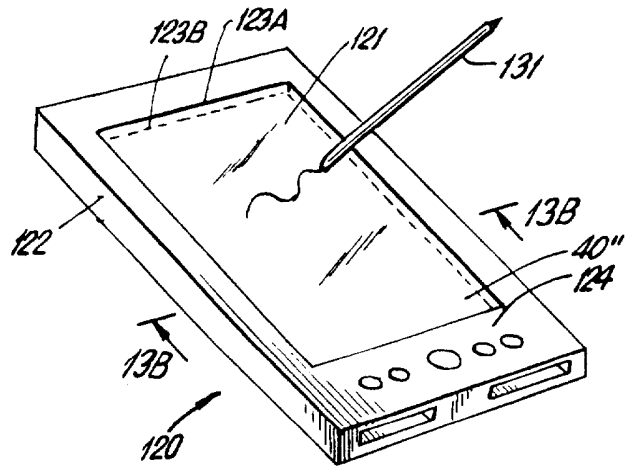

FIG. 13

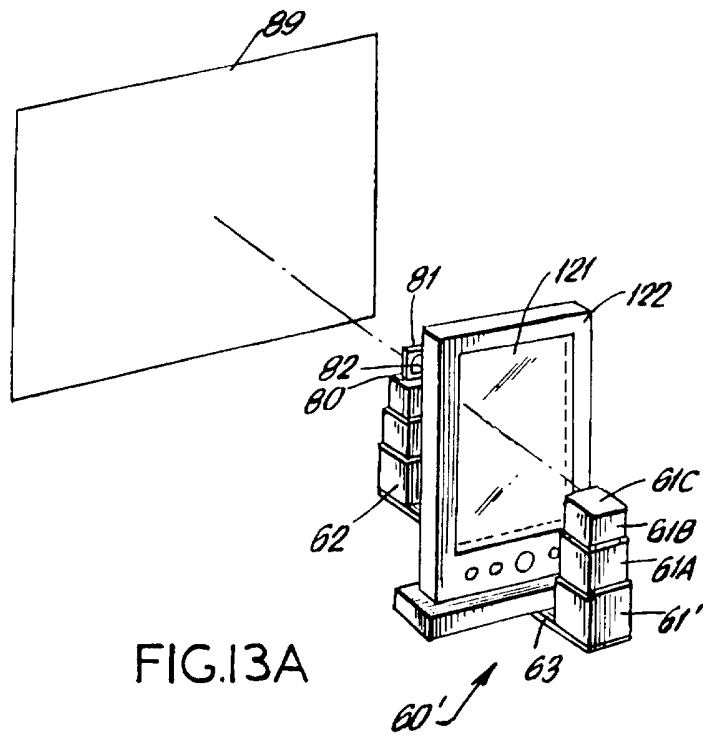

FIG. 13A

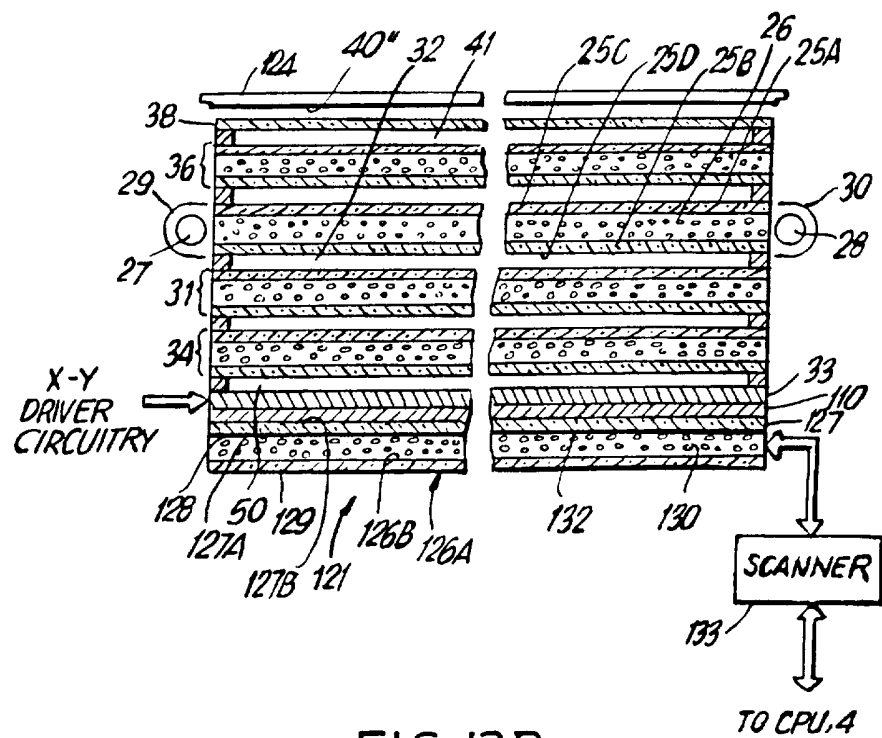
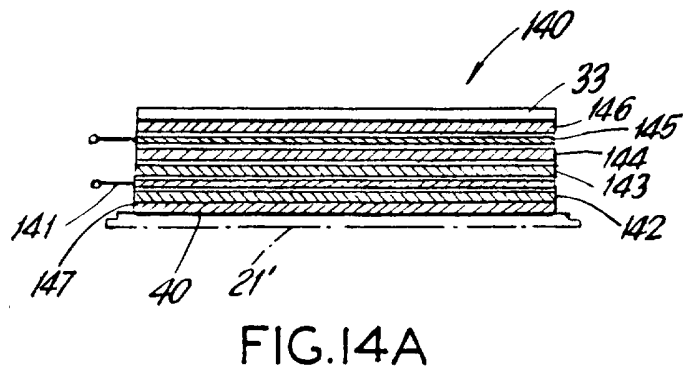
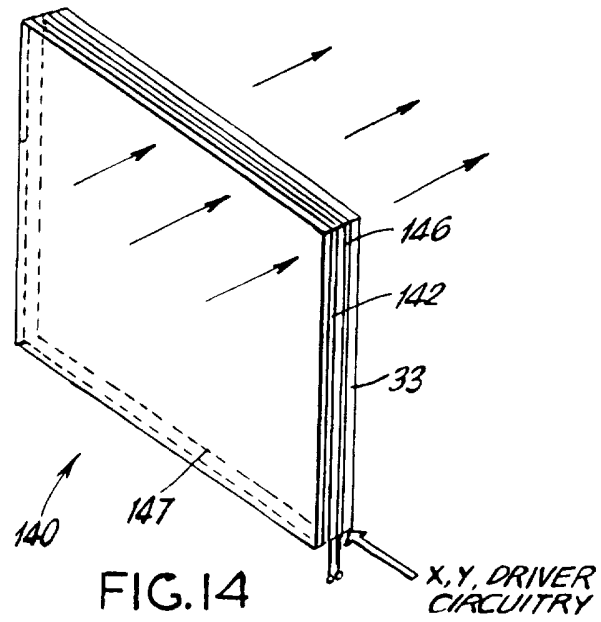

FIG. 13B



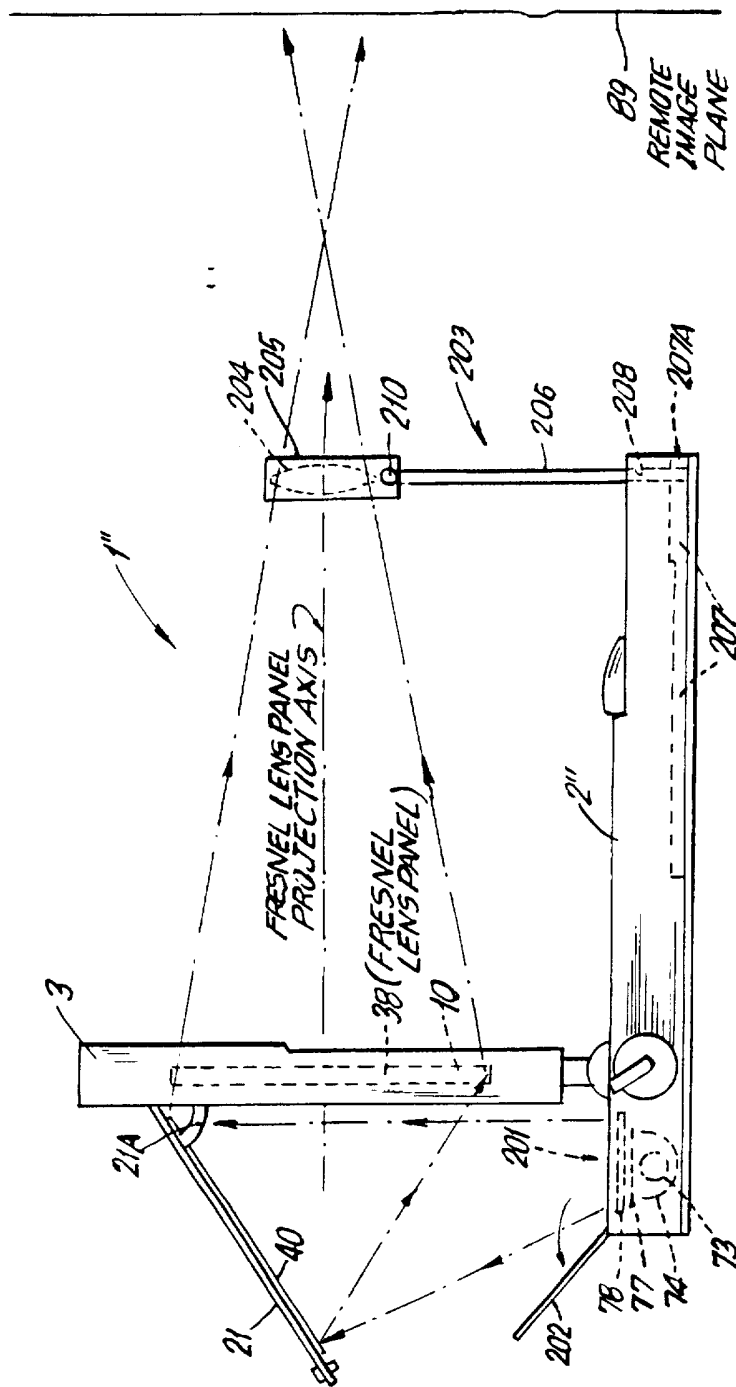

FIG. 15

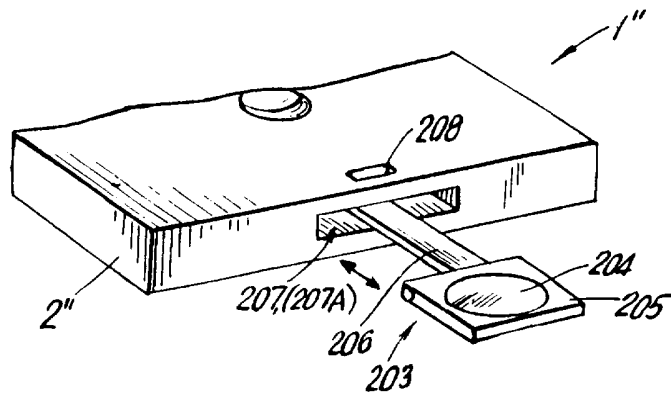

FIG. 15A

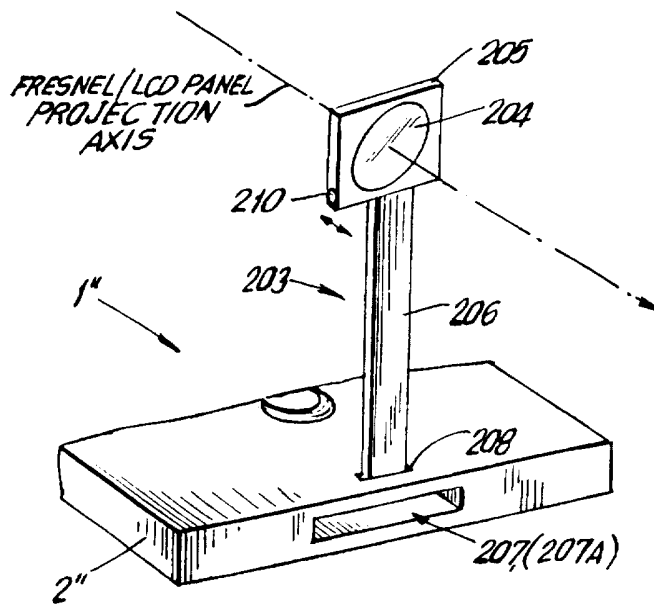

FIG. 15B

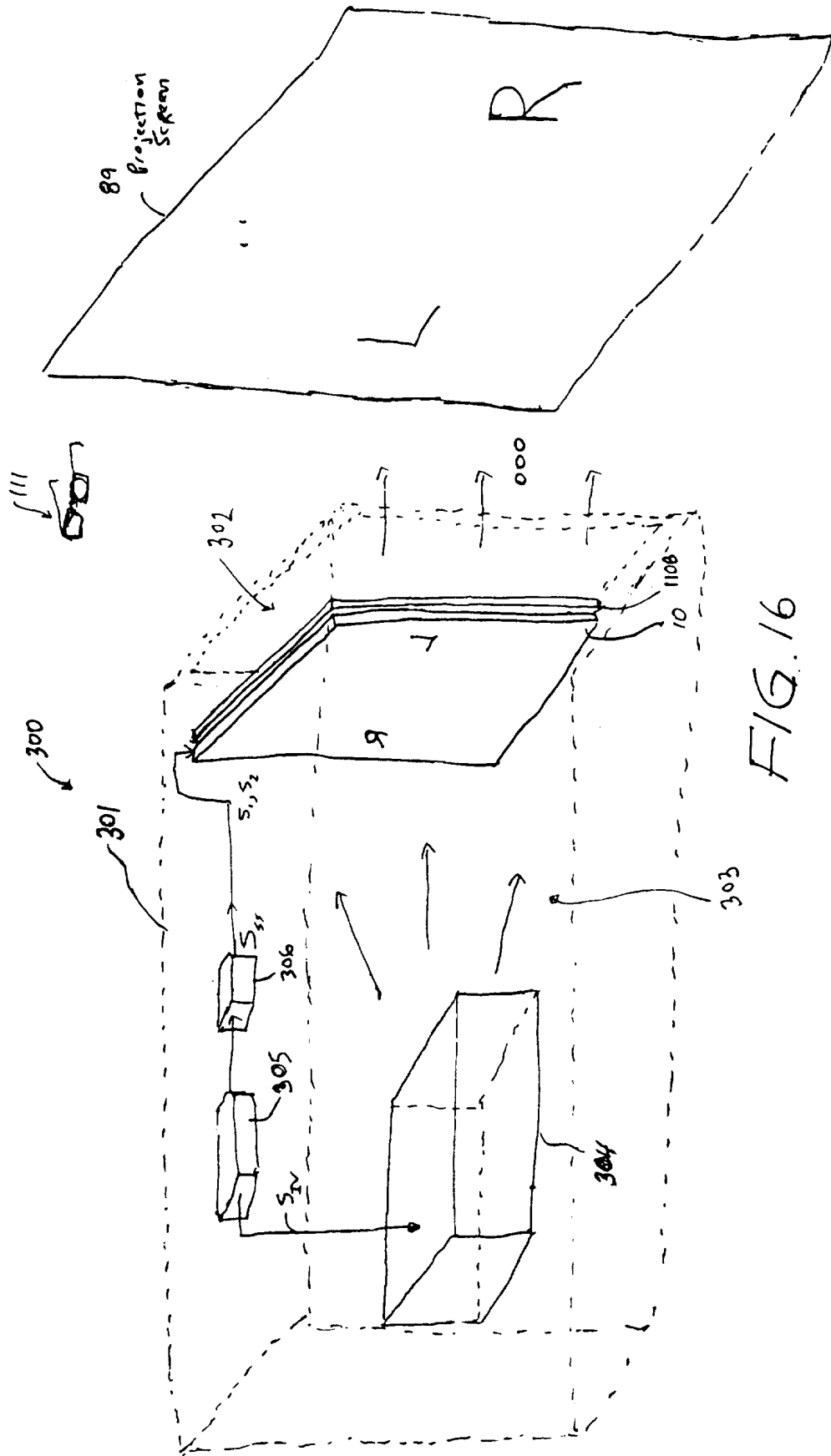

FIG. 16

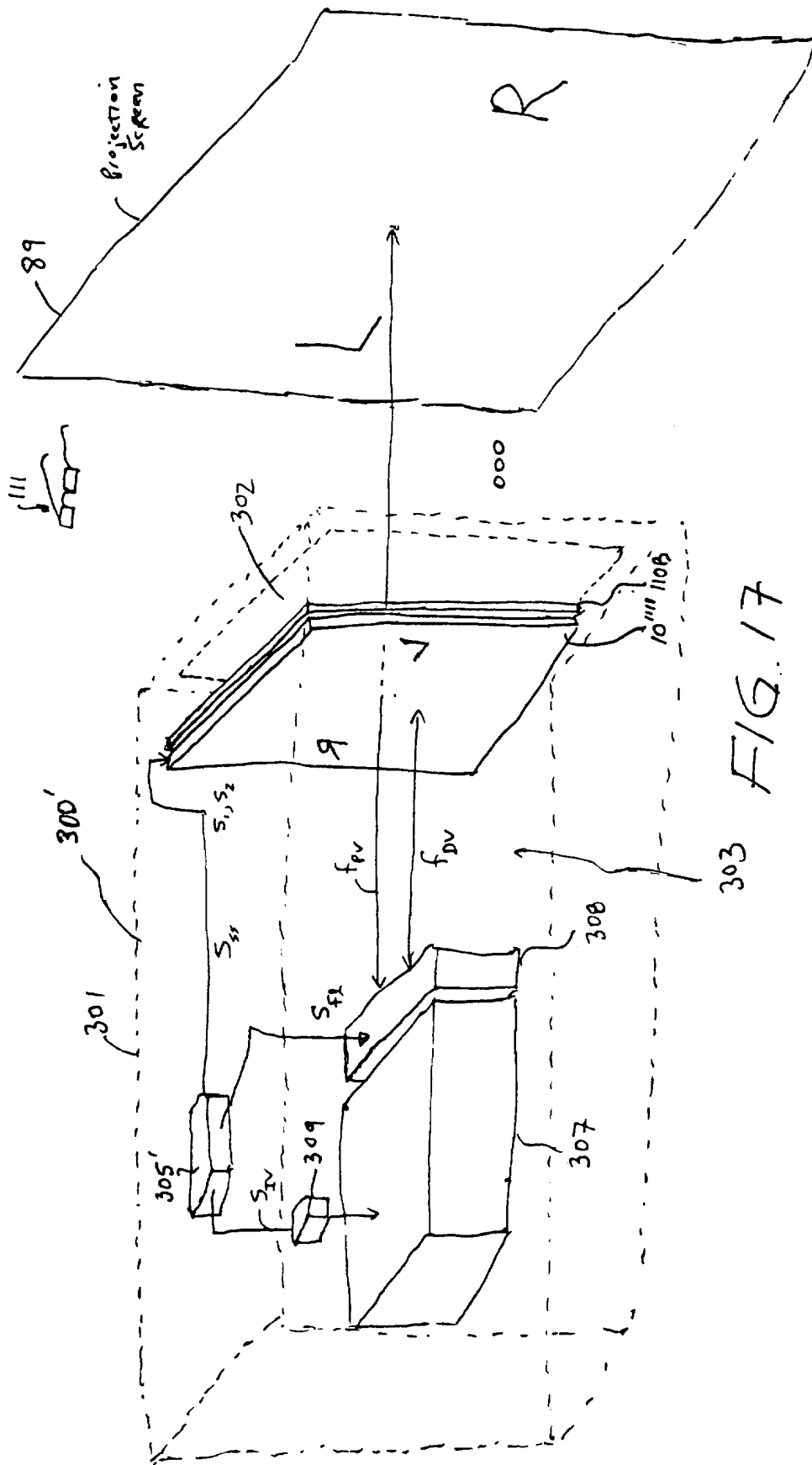

FIG. 17

INTERNATIONAL SEARCH REPORT

International application No.
PCT/US96/19718

A. CLASSIFICATION OF SUBJECT MATTER
 IPC(6) :G02F 1/13, 1/1335, 1/1347; G02B 21/56, 21/132
 US CL :349/5, 15, 57, 62, 64, 77, 86; 353/71, 122, Dig.3, Dig.5
 According to International Patent Classification (IPC) or to both national classification and IPC

B. FIELDS SEARCHED
 Minimum documentation searched (classification system followed by classification symbols)
 U.S. : 349/5, 15, 57, 58, 62, 64, 65, 68, 77, 86, 96; 353/71, 72, 74, 119, 122, Dig.3, Dig.5 ; 359/464, 465, 466; 345/4; 362/18, 31

Documentation searched other than minimum documentation to the extent that such documents are included in the fields searched

Electronic data base consulted during the international search (name of data base and, where practicable, search terms used)
 APS
 search terms : direct view?, projection mode, scatter?, diffuser?, PDLC

C. DOCUMENTS CONSIDERED TO BE RELEVANT

Category*	Citation of document, with indication, where appropriate, of the relevant passages	Relevant to claim No.
X ----- Y	JP 6-167689 A (SHARP CORP.) 14 June 1994 (14/06/94) , abstract, Figs. 4-13.	1-4, 6, 21-24, 26 ----- 7-10, 27-30
X,P	US 5,537,233 A (MIURA ET AL) 16 July 1996 (16/07/96) , see entire document, Figs. 1-6.	21-24, 26, 29
Y	US 5,325,218 A (WILLETT ET AL) 28 June 1994 (28/06/94), col. 3, lines18-28, col. 5, line 49 - col. 6, line 27, Figs. 2, 6, 7.	7, 8, 10, 27, 28, 30
Y ----- A	US 5,353,075 A (CONNER ET AL) 04 October 1994 (04/10/94), col. 3, lines 34-48, Figs. 1-6.	9, 29 ----- 1, 21

Further documents are listed in the continuation of Box C. See patent family annex.

* Special categories of cited documents:	*T	later document published after the international filing date or priority date and not in conflict with the application but cited to understand the principle or theory underlying the invention
*A		document defining the general state of the art which is not considered to be of particular relevance
*E	*X	earlier document published on or after the international filing date
*L		document which may throw doubts on priority claim(s) or which is cited to establish the publication date of another citation or other special reason (as specified)
*O	*Y	document referring to an oral disclosure, use, exhibition or other means
*P	*&	document published prior to the international filing date but later than the priority date claimed
		document of particular relevance; the claimed invention cannot be considered novel or cannot be considered to involve an inventive step when the document is taken alone
		document of particular relevance; the claimed invention cannot be considered to involve an inventive step when the document is combined with one or more other such documents, such combination being obvious to a person skilled in the art
		document member of the same patent family

Date of the actual completion of the international search 21 MARCH 1997	Date of mailing of the international search report 27 MAR 1997
--	---

Name and mailing address of the ISA/US Commissioner of Patents and Trademarks Box PCT Washington, D.C. 20231 Facsimile No. (703) 305-3230	Authorized officer TAI DUONG Telephone No. (703) 308-4873
--	---

INTERNATIONAL SEARCH REPORT

International application No.
PCT/US96/19718**Box I Observations where certain claims were found unsearchable (Continuation of item 1 of first sheet)**

This international report has not been established in respect of certain claims under Article 17(2)(a) for the following reasons:

1. Claims Nos.:
because they relate to subject matter not required to be searched by this Authority, namely:

2. Claims Nos.:
because they relate to parts of the international application that do not comply with the prescribed requirements to such an extent that no meaningful international search can be carried out, specifically:

3. Claims Nos.:
because they are dependent claims and are not drafted in accordance with the second and third sentences of Rule 6.4(a).

Box II Observations where unity of invention is lacking (Continuation of item 2 of first sheet)

This International Searching Authority found multiple inventions in this international application, as follows:

Please See Extra Sheet.

1. As all required additional search fees were timely paid by the applicant, this international search report covers all searchable claims.
2. As all searchable claims could be searched without effort justifying an additional fee, this Authority did not invite payment of any additional fee.
3. As only some of the required additional search fees were timely paid by the applicant, this international search report covers only those claims for which fees were paid, specifically claims Nos.:

4. No required additional search fees were timely paid by the applicant. Consequently, this international search report is restricted to the invention first mentioned in the claims; it is covered by claims Nos.:
1-10, 19, 21-30 and 39

Remark on Protest

- The additional search fees were accompanied by the applicant's protest.
 No protest accompanied the payment of additional search fees.

BOX II. OBSERVATIONS WHERE UNITY OF INVENTION WAS LACKING

This ISA found multiple inventions as follows:

This application contains claims directed to the following patentably distinct species of the claimed inventions:

Species I, claims 2-10 and 22-30, directed to an image display system comprising an electrically-addressable spatial light modulation panel which is mounted closely adjacent to the electro-optical panel (Figure 16).

Species II, claims 11-18, 20, 31-38 and 40, directed to an image display system comprising a light modulation structure (an electrically-addressable spatial light modulation panel or a slide-film structure) which is disposed near the light producing means (Figure 17).

Currently, claims 1, 19, 21 and 39 are generic.

The inventions listed as species I and II do not meet the requirements for Unity of Invention for the following reasons:

The listed species of inventions lack unity because there are no common "special technical features" with each claimed species. It is noted that the term "special technical features" is defined as meaning those technical features that define a contribution which each of the inventions considered as a whole, makes over the prior art. In the instant application, the "special technical features" are the particular arrangements of the light modulation panel with respect to the electro-optical panel (Figure 16), and the light producing means (Figure 17). The "special technical features" of species I are mutually exclusive with respect to the "special technical features" of species II. Therefore, there are no common "special technical features" between species I and II.

In order for more than one species to be examined, the appropriate additional examination fees must be paid.