

⑫ **EUROPEAN PATENT APPLICATION**

⑲ Application number: 82300302.5

⑤① Int. Cl.³: **H 04 R 19/00**
H 04 R 1/40

⑳ Date of filing: 21.01.82

③① Priority: 15.05.81 US 264011

④③ Date of publication of application:
01.12.82 Bulletin 82/48

⑧④ Designated Contracting States:
AT BE CH DE FR GB IT LI LU NL SE

⑦① Applicant: **BEARD, Terry D.**
2471 Sagra Street
Thousand Oaks, CA 91360(US)

⑦② Inventor: **BEARD, Terry D.**
2471 Sagra Street
Thousand Oaks, CA 91360(US)

⑦④ Representative: **Crawford, Andrew Birkby et al,**
A.A. THORNTON & CO. Northumberland House 303-306
High Holborn
London WC1V 7LE(GB)

⑤④ Travelling wave electrical/acoustic transducer system and a microphone and loudspeaker incorporating such a system.

⑤⑦ A high efficiency electrical/acoustic transducer system formed from a plurality of electrical/acoustic transducer stages (6, 26, 8; 8, 28, 10; etc.) electrically and mechanically connected in succession to propagate electric and acoustic signals through the successive stages. An inductance network ($L/2$, L , L , L , $L/2$) is connected in circuit with the transducer (6, 26, 8; 8, 28, 10; etc.) stages to slow the electrical signal propagation speed through the system to a speed which is substantially synchronous with the acoustic signal propagation speed, enabling the travelling electrical and acoustic waves to interact and to efficiently transform one form of energy into the other. In the preferred embodiment a plurality of acoustically transparent screens (6, 8, 10, 12, 14, 16, 18, 20, 22) form the transducer plates, each successive stage sharing a screen (8, 10, 12, 14, 16, 18, 20) in common with the previous stage, and the inductance network renders the input impedance substantially resistive. The invention is applicable to both acoustic speakers and microphones.

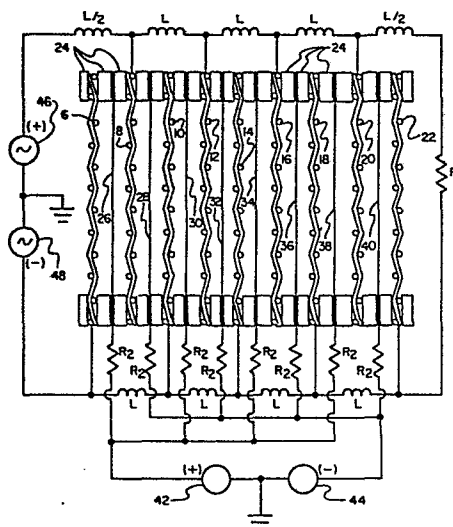

FIG.2.

TRAVELLING WAVE ELECTRICAL/ACOUSTIC
TRANSDUCER SYSTEM AND A MICROPHONE AND
LOUDSPEAKER INCORPORATING SUCH A SYSTEM

This invention relates to electrical/acoustic transducers, and more particularly to a traveling wave transducer in which electrical and acoustic signals are transmitted in coordination with each other through the transducer system.

5 Electrical/acoustic transducers can be used either as speakers to transform input electrical signals into output acoustic signals, or as microphones to transform input acoustic signals into output electrical signals. One variety of electrical/acoustic transducer is an electrostatic transducer which
10 consists of a pair of parallel plates, between which a flexible membrane is positioned. An electrical charge is established on the membrane, which is caused to vibrate between the plates as a result of either input electrical signals applied to the plates, or input acoustic waves striking the membrane.
15 Functioning as an audio speaker, a voltage differential corresponding to the input electrical signal is applied across the plates. This causes the charged membrane to flex toward the plate of opposite polarity, resulting in a membrane vibration at the input frequency for an AC electrical input. The movement of the membrane sets up acoustic waves, which are perceived
20 as an audio output. A similar apparatus can be used as a microphone, with the inputs and outputs reversed. In the microphone mode, an input acoustic signal causes the charged membrane to vibrate between the two plates, which in turn induces a flow
25 of current between the plates and a load which can be perceived as an electrical output.

Such electrostatic transducers are theoretically quite efficient. However, the theoretical efficiency is not available in practice because of the reactive nature of the transducer
30 as an electrical load. This results in a requirement for a

considerably greater amount of input energy than the energy output of the system in the form of either acoustic or electrical signals. Thus, there is a need for an electrical /acoustic transducer capable of operating at higher efficiencies than presently available transducers.

SUMMARY OF THE INVENTION

In view of these and other problems associated with the prior art, it is an object of the present invention to provide a novel and improved electrical/acoustic transducer having a greater operating efficiency and corresponding lower energy input requirement than presently available electrical/acoustic transducers.

Another object of the invention is the provision of a novel and improved electrical/acoustic transducer which appears as a substantially resistive load to an input signal, thereby reducing reactive losses associated with prior transducers.

A further object of the present invention is the provision of a traveling wave electrical/acoustic transducer in which electrical and acoustic signals are propagated through the transducer in synchronism, enabling energy to be coupled between the electrical system and the acoustic wave, and resulting in an energy efficient transducer device.

These and other objects are achieved in the present invention by electrically and mechanically coupling a plurality of electrical/acoustic electrostatic transducer stages in succession, such that electrical and acoustic signals are propagated through successive stages. Impedance means in the form of inductance elements are connected to the various stages and together with the transducer capacitances form an electrical delay line which matches the propagation of an electrical signal through successive stages to a speed which is substantially synchronous with

0065810

-3-

the propagation speed of an acoustic signal through the transducer. By thus matching the propagation of electrical and acoustic signals through the succession of transducer stages, a marked increase in transducer efficiency is achieved. A terminal resistor is also matched with the characteristic impedance of the delay line, thereby reducing the amount of energy that would otherwise be dissipated in the resistor.

In a preferred embodiment, each transducer stage comprises a pair of opposed, substantially acoustically transparent plate members which are spaced apart from each other and establish an equivalent stage capacitance, and a flexible charge-supporting membrane supported midway between the plates. Each successive stage shares a plate with the previous stage, so that each plate except for the one at each end of the array forms a part of two stages. By connecting every other plate in association with an electrical signal of one polarity, connecting the remaining plates in association with an electrical signal of opposite polarity, applying a static charge of one polarity to every other membrane, and applying a static charge of opposite polarity to the remaining membranes, a compact and highly efficient device is achieved. Inductance networks are connected in circuit with the plate members to form an electrical delay line which matches the electrical propagation speed to the acoustic propagation speed through successive stages. The transducer thus appears as a non-reactive load to the driving source. If a greater membrane excursion is desired, the spacing between successive plate members can be enlarged by adding a plurality of intermediate inductive-capacitive delay stages to the various transducer stages, thereby slowing down the electrical signal propagation speed. If, on the other hand, the acoustic signal falls within a frequency spectrum characterized by wavelengths which are much greater than the spacing between successive plate members, synchronization of the electrical and acoustic

propagation speeds can be adequately achieved by simply making the inductance elements substantially short circuits.

These and other features and advantages of the invention will become apparent to those skilled in the art by a consideration of the following detailed description of preferred
5 embodiments of the invention, along with the accompanying drawings, in which:

DESCRIPTION OF THE DRAWINGS

Fig. 1 is a schematic diagram of an electrical delay line, the principle of which is employed in the invention;
10

Fig. 2 is a combined side view and electrical schematic diagram showing the construction of a transducer embodying the invention;

Fig. 3 is an end view of the device shown in Fig. 2;

Fig. 4 is a schematic diagram showing an equivalent electrical circuit for the device of Fig. 2;
15

Fig. 5 is a combined side view and schematic diagram showing a portion of a second embodiment of the invention, in which additional electrical delay stages are used, and

Fig. 6 is a schematic diagram of a third embodiment of the invention.
20

DETAILED DESCRIPTION OF PREFERRED EMBODIMENTS

Referring first to Fig. 1, an electrical delay line is shown which forms one of the theoretical underpinnings of the present invention. A general reference on delay lines is
25 provided in Chapter 22 of the text "The Feynman Lectures on Physics," Feynman, Leighton and Sands, California Institute of Technology. Connected across input terminals 2 and 4 are a series of inductance elements of substantially equal value, except for the first and last elements which are half the
30 inductance value of the others, and a plurality of capacitors connected between each successive pair of inductors and terminal 4. The delay line is terminated by a resistor R1 in series with the last inductance element. It is known that in such

0065810

-5-

delay lines, for input signals having a frequency well below $\sqrt{4/LC}$, the characteristic impedance of the line is approximately the square root of L/C , L being inductance in henrys and C capacitance in farads. For example, if the capacitor elements are each 10^{-8} farads (.01 μ f) and each inductor L is 10 millihenrys, then the characteristic impedance of the circuit would be about 1,000 ohms within the given frequency range. That is, for frequencies of up to about 20kHz, the circuit would act as a 1,000 ohm register across terminals 2 and 4, when terminated with a matching 1000 Ω resistor R_1 . The propagation of an electrical input signal at terminals 2 and 4 through the delay line would be delayed by the square root of LC at each successive LC stage, or in the above example by about 10^{-5} seconds per stage.

The invention utilizes the fact that sound traveling at 330 meters per second would travel about 3.3 mm in a 10^{-5} second interval, thereby making it theoretically possible to synchronize the propagation of electrical and acoustic signals through a transducer system by constructing the system to emulate a delay line, with each stage of the delay line physically spaced 3.3 mm apart from the next succeeding stage. In accordance with the invention, a series of electrostatic electrical/acoustic transducer stages are electrically and mechanically connected in succession to propagate electrical and acoustic signals through successive stages, and appropriate impedance means such as discrete inductance elements are connected to synchronize the travel of the electrical signal through the system with the traveling acoustic waves. It has been found that, when the propagation of the electrical and acoustic signals are substantially synchronized through a succession of electrostatic electrical/acoustic transducer stages, the resulting signal energy output of the coupled set of stages taken together exceeds the arithmetic sum of the individual stages operating independently of each other. The energy normally lost to a terminating resistor

in conventional electrostatic speaker systems is instead passed on to the next stage in the present invention. The result is a more efficient transducer system which requires a smaller energy input for a given output level, and which is capable
5 of producing a greater output for a given input level.

An implimentation of the invention as a plurality of electrically and mechanically coupled electrostatic electrical/acoustic transducer stages is shown in Fig. 2. A plurality of plate members in the form of grids or wire mesh screens 6, 8,
10 10, 12, 14, 16, 18, 20 and 22 (shown with exaggerated widths in Fig. 2) are supported in a parallel array by a plurality of non-conductive spacing and support members 24 which support the periphery of the screens and space them equidistantly apart. Spacing and support members 24 also hold a plurality of flexible
15 membrane members 26, 28, 30, 32, 34, 36, 38 and 40 equidistantly spaced between each successive pair of screens, respectively. The membranes are preferrably formed from a thin mylar material which has been lightly aluminized sufficiently for the membrane to support a static electrical charge, whereby the membranes
20 flex towards one or the other of their adjacent screens in response to applied electrical field forces which accompany electric signals applied to the screens.

Each membrane together with the adjacent screens on either side form an electrical/acoustic transducer stage capable of
25 transducing electrical signals on the screen to an acoustic signal from the resulting membrane movement, or of transducing an acoustically induced movement of the membrane into an output electrical signal on the screens. Except for the outermost screens 6 and 22, it can be seen that each screen is common to
30 two transducer stages, thereby saving both materials and space.

As stated above, it is a feature of the invention that a plurality of electrical/acoustic transducer stages are made to

0065810

-7-

perform as an electrical delay line to enable a synchronization between electrical and acoustic signals propagated through the transducer system. To accomplish this object, a plurality of impedance elements in the form of inductors L are connected
5 respectively between each screen and the screen once removed, with half value inductors L/2 connected between screen 8 and an electrical input, and between screen 10 and a termination resistor R1.

10 It is desirable that the entire transducer system be as acoustically transparent as practicable, to minimize losses in the propagation of acoustic signals. For this purpose fairly open screens, for example of 1 mm mesh, formed from wire are used, along with thin lightly aluminized mylar membranes of about 6 micrometers thickness or less. As mentioned above, the
15 spacing between successive stages, that is, the spacing between the center lines of successive membranes or screens, is selected to synchronize the electrical and acoustic propagation speeds. With an inductance network and transducer stages producing a delay of 10^{-5} seconds per stage, the distance between stages
20 would be 3.3 mm for an assumed acoustic velocity of 330 meters per second.

The embodiment of Fig. 2 illustrates an electrical to acoustic transducer. Every other membrane 26, 30, 34 and 38 is charged to one polarity through respective coupling resistors R2
25 by a first voltage source 42, while the remaining membranes 28, 32, 36 and 40 are charged to the opposite polarity through respective coupling resistors R2 by a second DC voltage source 44. In general, the operating efficiency of the system will increase as the charge on the membrane is increased, but a
30 tendency of the membranes to arc limits the charge that can be applied to them. Immersing the membranes in a non-arcing gaseous environment permits them to be charged to higher voltages.

In the use of the invention as a speaker as in Fig. 2, an electrical input signal from an AC source 46 to be transduced to an acoustic signal is applied through the upper inductive network to every other screen 8, 12, 16 and 20, while the polar mirror of the input electrical signal is applied from equivalent AC source 48 through the lower conductance network to the remaining screens 6, 10, 14, 18 and 22; sources 46 and 48 may conveniently be provided from a center tapped transformer. In this manner the screens forming the plates of each successive transducer stage are charged to opposite polarities, creating an electric field which causes the charged membrane between the two screens to flex away from the screen of like polarity and towards the screen of opposite polarity. This in turn creates an acoustic wave which arrives at the next membrane at the same time the electric input signals have reached the screens surrounding that membrane and set up a similar electric field as in the first transducer stage. Thus, the second membrane is acted upon by both a traveling electric field and the acoustic waves set up by the preceding membrane, and produces an acoustic wave which is considerably greater than that produced by the first stage. The acoustic wave continues to travel through the system, arriving at each successive membrane at the same time the electrical input signals cause the screens on either side of the membrane to establish an electrical field which cooperates with the arriving acoustic wave in flexing the associated membrane.

Optimally, the output energy with the described transducer should approach the square of the arithmetic sum of the output energies of a similar number of individual transducer stages acting independent of each other. Analytically, this may be attributed to two factors. First, each transducer stage arithmetically adds to the pressure of the traveling acoustic wave, so that the output pressure from the eight stage device shown in Fig. 2 would be eight times as great as the output pressure from a single stage. However, the energy in an acoustic wave is proportional to the square of the pressure. Thus, eight stages connected in succession would produce an output of sixty-four units of acoustic energy, while the same stages



0065810

-9-

operating independent of each other would each produce only one unit of output acoustic energy, for a total of eight units. Secondly, the transducer system of Fig. 2 appears substantially as a purely resistive load to the input, passing electrical energy stored in the reactive capacitance of one stage on to the next instead of dissipating it immediately in a damping resistor as is necessary with conventional electrostatic speakers. This consideration again increases the efficiency of the system by a factor approximately equal to the number of stages, assuming the efficiency of each stage is low. The combined effect is to increase the efficiency of the described system by approximately the square of the number of stages, compared with a conventional single stage electrostatic transducer. While the above situation applies to a lossless device, and in practice some losses are experienced due to the resistive load and the movement of the individual membranes, the efficiency of the system will still greatly exceed that of individual single stage electrostatic transducers.

The transducer described thus far has an upper frequency limitation of approximately $\sqrt{4/LC}$. At higher frequencies, the electrical signal is exponentially attenuated as it progresses through the system. For the example given above in which the capacitance between the plates of each stage was 10^{-8} farads and inductors of 10 millihenrys were used (5 millihenrys for the terminal inductance elements), the upper frequency limit would be about 32 kHz. Since the capacitance associated with each stage is directly proportional to the area of the elements and inversely proportional to the distance between stages, the upper frequency limitation can be modified by adjusting the physical configuration of the transducer elements.

An end view of the transducer system illustrated in Fig. 2 is shown in Fig. 3. In this configuration, spacer and support

elements 24 are seen to be generally rectangular. Small pads 50 are shown in place between the screens and membranes, limiting the area of membrane movement essentially to the region between pads. Smaller area elements could also be used, and the pads
5 eliminated.

Referring now to Fig. 4, an equivalent circuit of the system of Fig. 2 is depicted, including an equivalent resistance R_{eq} associated with each transducer stage. In this circuit the capacitance associated with each stage is represented by an equivalent capacitor C_{eq} . Because the electrostatic elements interact with the acoustic field, they do not appear as pure capacitances in the equivalent circuit, but rather appear as capacitors C_{eq} bridged by resistors R_{eq} in the case of a speaker, or as capacitors bridged by power sources in the case of a microphone.
10 For a speaker, it can be shown that R_{eq} is to the first order proportional to the square of the spacing between successive stages, and inversely proportional to the square of the electrostatic charges on the membranes. R_{eq} exists because of and represents the conversion of electrical energy into acoustic energy and is
15 generally small compared to the characteristic impedance R_1 of the delay line, if the efficiency of the transducer is fairly low. As the efficiency rises, as is the case with a well designed example of the invention, R_{eq} becomes smaller and has a significant effect on the characteristic impedance of the electrical
20 delay and should be taken into account for optimum design.

The first order square relationship described above is most accurately applied to lower frequencies. In the case of higher frequencies, on the other hand, the acoustic waves radiated back to the first stages by the later excited stages will be delayed,
25 causing the propagation of the electrical signal to go out of phase with the acoustic propagation. The principal effect is that at higher frequencies some variation in input impedance and signal propagation may be expected.
30

The above frequency limitation may be alleviated to a great extent by a judicious selection of the spacing between the transducer elements and of the size of the inductors. The relationship stated above whereby R_{eq} is proportional to the square of the spacing between successive screens or membranes (which spacings in the preferred embodiment are equal) suggests that the efficiency of the system can be increased by reducing the spacing between the screens and membranes. However, as the spacing is made smaller, C_{eq} increases since it is inversely proportional to the spacing. With conventional single stage electrostatic transducers such an increase in capacitance would tend to decrease operating efficiency and also to limit the range of the frequency spectrum over which the device could operate. In the present invention, on the other hand, the efficiency problem may be compensated for by an increase in the size of the inductor elements, thereby making possible the greater efficiency of smaller spacing without limiting the operating frequency of the device.

While the invention thus far has been described in terms of an audio speaker with an input electrical signal, an output audio signal, and electrical and audio waves propagating from left to right in Figs. 2 and 4, it should be understood that the principles of the invention are equally applicable to a microphone which transduces acoustic to electrical signals. A microphone could be constructed by merely replacing voltage sources 46 and 48 with a load and propagating input acoustic signals from right to left.

Referring now to Fig. 5, another embodiment of the invention is shown which allows for greater membrane excursions and thereby higher pressure, more efficient acoustic waves. In this embodiment intermediate inductive-capacitive delay stages are connected between successive membranes in the delay line to retard the propagation speed of an electrical signal through the system. As a result, a greater spacing between stages and a greater membrane

excursion becomes possible. In the implementation of this concept shown in Fig. 5, an intermediate inductor L' at the top of the delay line and intermediate screen $8'$ are added between membranes 26 and 28, while intermediate inductor L' at the bottom of the delay line and intermediate screen $10'$ are added between membranes 28 and 30. Each added screen in effect forms a new capacitive element with its adjacent screen. Similar inductors and screens are added to the remaining stages in the system, the size of each inductor and spacing between screens being selected to achieve the desired slowing of the electrical propagation speed.

The inventive concept of incorporating an electrostatic electrical/acoustic transducer in a delay line with an essentially resistive input impedance can also be applied to a single transducer stage, as shown in Fig. 6. In this embodiment a single electrostatic speaker stage represented by C_{eq} is the first element of an immediately terminated delay line. C_{eq} represents the equivalent capacitance of a conventional electrostatic speaker, and is connected through an inductance element of $L/2$ value to an input signal source 52. The system is terminated by another inductor element of $L/2$ value connected in series with a termination resistor R_2 across C_{eq} . For most efficient operation, the value of R_2 is $\sqrt{L/C}$. The system shown is capable of efficiencies up to double the efficiency of the electrostatic speaker operating by itself. Again, the system could be used as a microphone by simply replacing signal source 52 with a load.

CLAIMS:

1. An energy efficient electrical/acoustic transducer system, comprising:

a plurality of electrostatic electrical/acoustic transducer stages electrically and mechanically connected in succession to propagate electrical and acoustic signals through successive stages, said transducer stages presenting a predetermined input impedance, and

impedance means connected to said transducer stages to substantially match the propagation of an electrical signal through the successive stages to a speed which is substantially synchronous with the propagation speed of an acoustic signal through the successive stages,

whereby an input signal to the system is transduced to an output signal, the energy output of which is greater than the energy output of a similar single stage transducer.

2. The electrical/acoustic transducer system of claim 1, said impedance means comprising a plurality of inductor means connected respectively in circuit with said transducer stages, said transducer stages each being characterized by respective input capacitances, said inductor means together with the capacitive transducer stages comprising an electrical delay line having the desired electrical propagation speed.

3. The electrical/acoustic transducer system of claim 2, further comprising intermediate electrical delay stages connected to successive transducer stages to retard the propagation speed of an electrical signal through the system, and thereby permitting a greater

physical spacing between successive stages for a given frequency response range.

4. An energy efficient electrical/acoustic transducer system, comprising:

a) a plurality of electrostatic/acoustic transducer stages, each stage comprising:

1) a pair of opposed, substantially acoustically transparent plate members spaced apart from each other, and establishing a stage capacitance, and

2) a flexible membrane member capable of supporting a static electrical charge, said membrane member being positioned between said plate means for flexing towards either one of said plate means in response to applied electric field force,

b) means supporting said transducer stages in a substantially linear array with a predetermined spacing between successive stages, the membrane members of the various stages being mutually aligned to propagate an acoustic signal through successive stages,

c) means for applying a static electrical charge to the membrane member of each transducer stage, and

d) inductance means connected in circuit with the plate members to form a delay line therewith, the electrical propagation speed along said delay line being substantially in synchronism with the propagation speed of an acoustic signal through successive transducer stages, whereby an input signal applied at one end of the array of transducer stages is transduced to an output signal at the other end of the array.

5. The transducer system of claim 4, further comprising a plurality of intermediate inductive-capacitive delay stages connected respectively to

- 3 -

successive transducer stages to retard the propagation speed of an electrical signal through the system, thereby permitting a greater spacing between stages and a greater membrane member excursion for a given frequency response range.

6. An acoustic speaker, comprising:

a) a plurality of substantially acoustically transparent, equidistantly spaced, parallel plate members, each successive pair of plate members having an associated equivalent capacitance,

b) a plurality of flexible, charge supporting membranes respectively secured substantially equidistantly between adjacent pairs of plate members,

c) an inductance circuit connected in circuit with the plate members to form a delay line therewith, the propagation speed of an input electrical signal along the delay line being substantially synchronous with the propagation speed of an induced acoustic signal between successive membranes, said inductance circuit comprising:

1) a first inductance network comprising one or more inductance elements connected between every other plate member, respectively, and

2) a second inductance network comprising one or more inductance elements connected between the remaining plate members, respectively, and

d) means for applying a static electrical charge of one polarity to every other membrane, and a static electrical charge of opposite polarity to the remaining membranes,

e) one of said inductance networks being adapted to receive an input electrical signal, and the other of said inductive networks being adapted to receive a signal which is the polar mirror of said input signal, whereby an input A.C. electrical signal induces a corresponding

acoustic movement of the membranes, and the electrical signal is propagated through the speaker substantially in synchronism with the induced membrane movements, thereby increasing the speaker's electro-acoustic conversion efficiency to a level greater than that of a similar single-membrane electrostatic speaker.

7. An acoustic microphone, comprising:

a) a plurality of substantially acoustically transparent, equidistantly spaced, parallel plate members, each successive pair of members having an associated equivalent capacitance,

b) a plurality of flexible, charge supporting membranes secured respectively between adjacent pairs of plate members,

c) an inductance circuit connected with the plate members to form a delay line therewith, the propagation speed of an input acoustic signal between successive membranes being substantially synchronous with the propagation speed of an induced electrical signal along the delay line, said inductance circuit comprising:

1) a first inductance network comprising one or more inductance elements connected between every other plate member, respectively, and

2) a second inductance network comprising one or more inductance elements connected between the remaining plate members, respectively, and

d) means for applying a static electrical charge of one polarity to every other membrane, and a static electrical charge of opposite polarity to the remaining membranes,

e) an outer one of said membranes being adapted to receive an input acoustic signal and to transmit said acoustic signal to the other membranes in succession, the propagation of the acoustic signal through each

- 5 -

successive membrane inducing a corresponding electrical signal which is amplified and propagated along the delay line substantially in synchronism with the acoustic signal, whereby the total amplification of the induced electrical signal exceeds the arithmetic sum of the amplifications imparted by a similar number of single-membrane electrostatic microphones operating independent of each other.

8. An improved electrical/acoustic transducer system, comprising:

an electrostatic electrical/acoustic transducer stage, said transducer stage having an equivalent capacitance, and

inductive circuit means connected in circuit with said transducer stage to form a delay line therewith having a substantially resistive input impedance.

9. The transducer system of claim 8, said transducer stage having an equivalent capacitance of C, said inductive circuit means comprising a pair of inductor elements each having an inductance of $L/2$ to one side of the transducer stage, and further comprising a terminating resistor means having a resistance of $\sqrt{L/C}$ connected in series with one of said inductor elements across the transducer stage.

10. The apparatus of claims 2, 4, 6, 7 or 8, wherein the inductance means together with the capacitance of the remaining apparatus presents a substantially resistive input impedance.

11. An energy efficient electrical/acoustic transducer system, comprising:

at least one electrostatic electrical/

acoustic transducer stage electrically connected in succession to propagate electrical and acoustic signals through successive stages, and having an input at one end,

impedance means connected in circuit with each of said transducer stages to produce with said stages a combined characteristic impedance, and

a terminal resistance means connected in circuit with said transducer stages and impedance means at the opposite end thereof, said terminal resistance means substantially matching the combined characteristic impedance of the transducer stages and impedance means, and thereby reducing the amount of power dissipated in said resistance means.

1/2

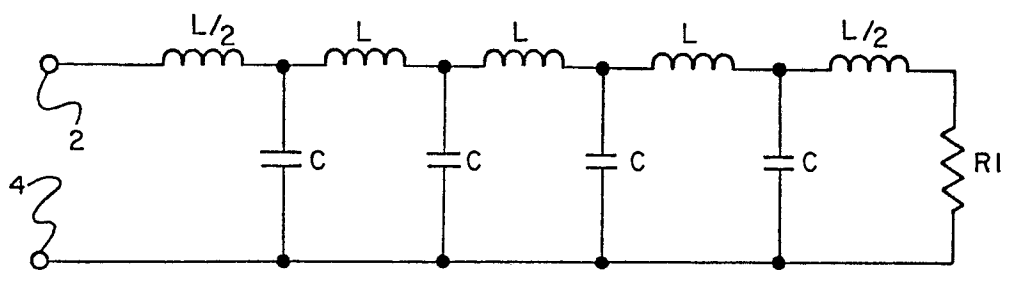

FIG. 1.

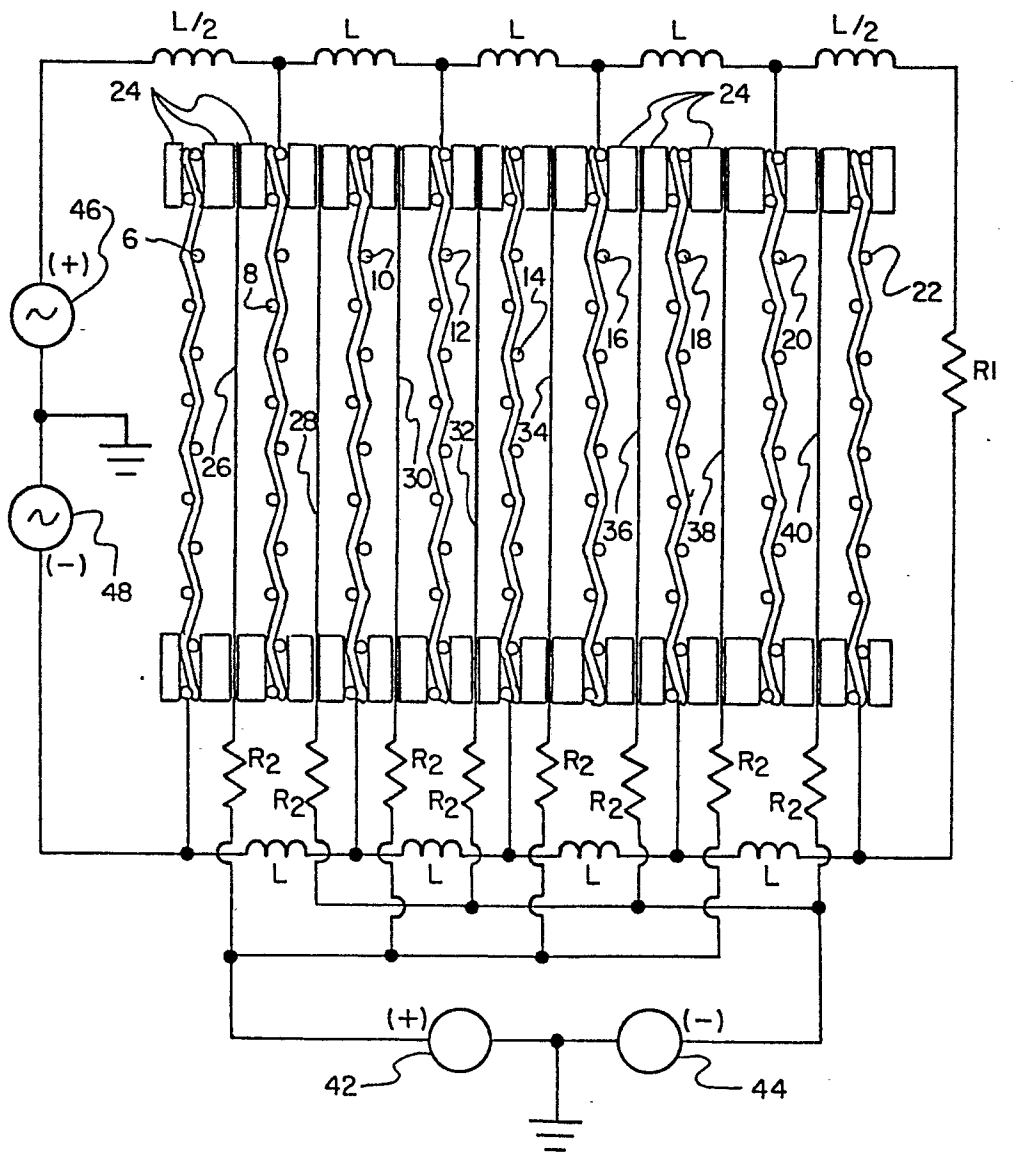

FIG. 2.

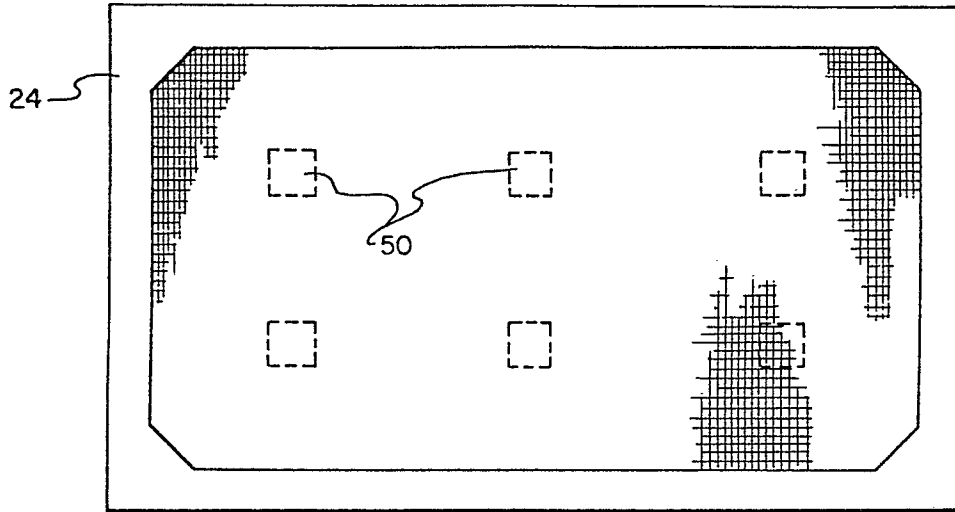

FIG. 3.

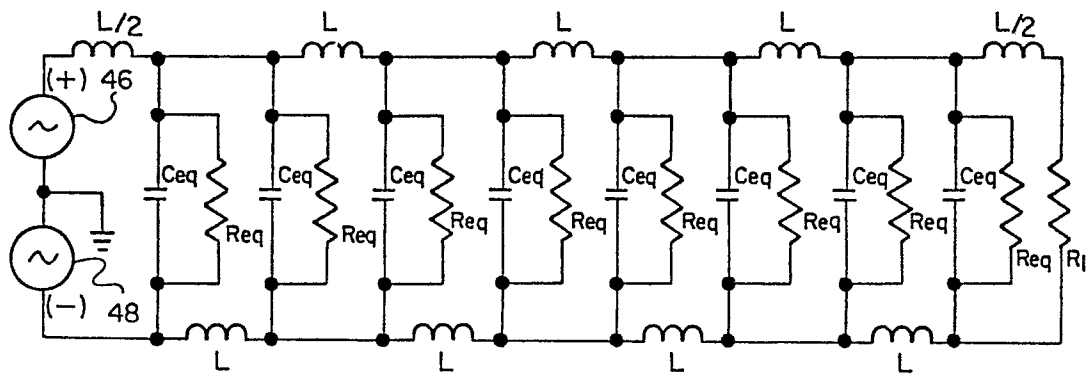

FIG. 4.

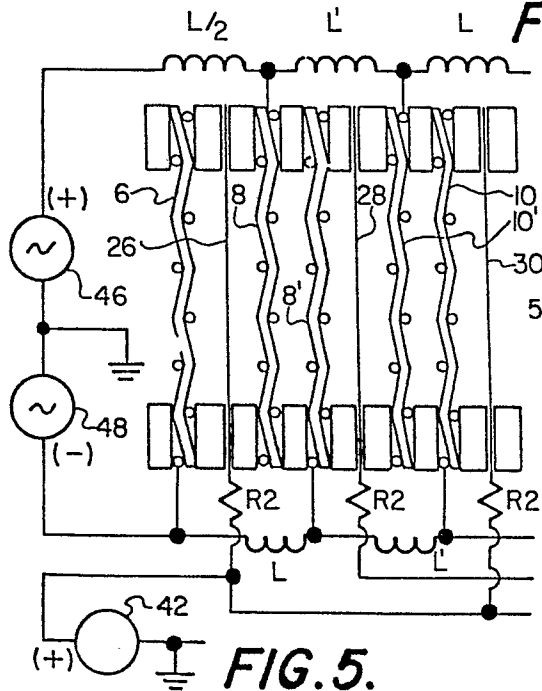

FIG. 5.

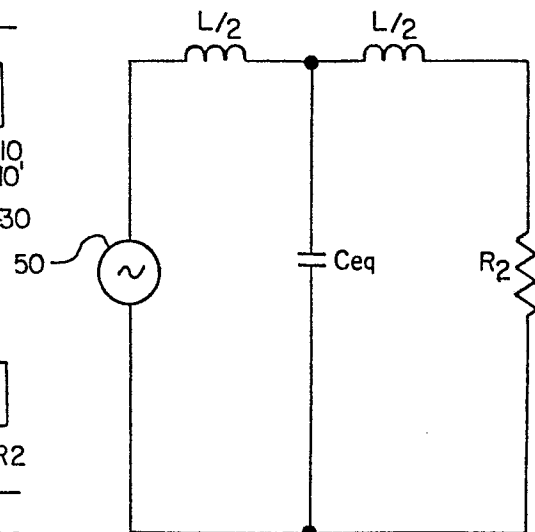

FIG. 6.