

(12) STANDARD PATENT
(19) AUSTRALIAN PATENT OFFICE

(11) Application No. **AU 2013201665 B2**

(54) Title
OVERLAP ARRANGEMENT OF AT LEAST TWO DECKING PLANKS

(51) International Patent Classification(s)
E04G 5/08 (2006.01) **E04G 7/02** (2006.01)
E04G 1/00 (2006.01)

(21) Application No: **2013201665** (22) Date of Filing: **2013.03.19**

(30) Priority Data

(31) Number	(32) Date	(33) Country
20 2012 101 000.3	2012.03.21	DE

(43) Publication Date: **2013.10.10**

(43) Publication Journal Date: **2013.10.10**

(44) Accepted Journal Date: **2015.05.07**

(71) Applicant(s)
Wilhelm Layher Verwaltungs-GmbH

(72) Inventor(s)
KRELLER, Helmut

(74) Agent / Attorney
Griffith Hack, GPO Box 4164, Sydney, NSW, 2001

(56) Related Art
DE 20318090

ABSTRACT

The invention relates to an overlap arrangement of at least two decking planks (22, 23), for example for construction scaffolding (34). It comprises a first decking plank (23) composed of metal, and a second decking plank (22) composed of metal. Each decking plank (22, 23) has a decking surface (24, 25) composed of sheet metal (84), which is provided with essentially round passage holes (27, 31), which are delimited, in each instance, by a beaded and circumferential hole edge (28, 32). The first decking plank (23) and the second decking plank (22) are braced, relative to one another, without play, in releasable manner, by means of a locking screw (20) composed of metal, to prevent displacement relative to one another in a displacement plane (21) that runs parallel to their decking surfaces (24, 25), and to prevent lift-off from one another, with force fit and shape fit, wherein the locking screw (20) is screwed in, with its thread, without any plastic deformation and without plastic widening of the hole edge (32) of a passage hole (31) of at least one of the decking planks (23).

Fig. 2

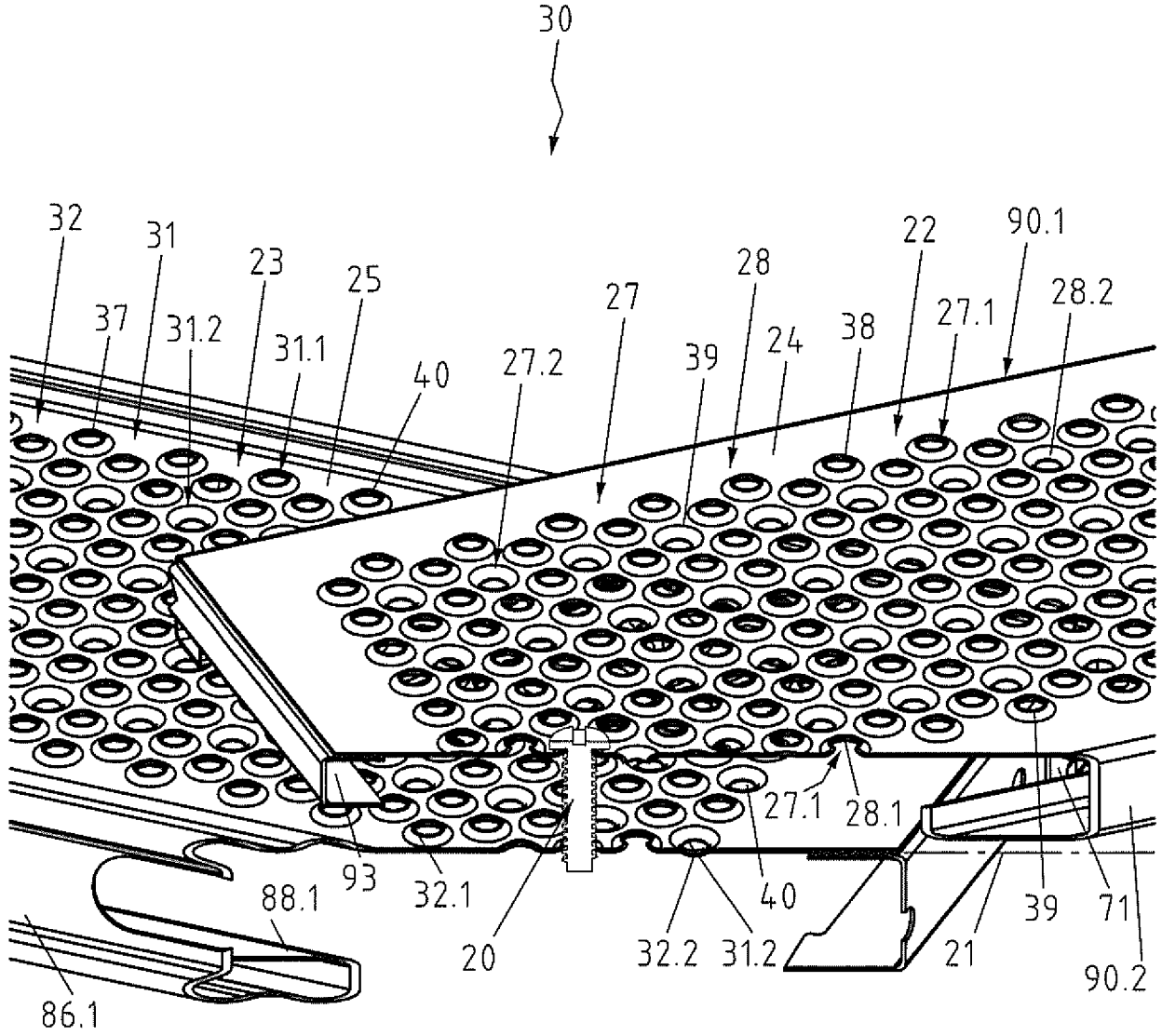

Fig. 2

2013201665 15 Apr 2015

OVERLAP ARRANGEMENT OF AT LEAST TWO DECKING PLANKS

Technical Field

The present invention generally relates to an overlap arrangement of at least two decking planks.

Background Art

When setting up scaffolding, particularly so-called system scaffolding, there can be set-up regions or placement regions, for example in the region of corners of buildings, in which no standardized attachment of scaffold decks is possible and/or in which gaps of wall regions must be bridged or where it is supposed to be possible to provide scaffolding elements that can be walked on. In such regions, for example, the scaffold decks are disposed to overlap with their end regions, and to lie at a slant one on top of the other, in order to be able to make a continuous decking surface available. In many cases, decking planks composed of metal are used as scaffold decks. Such decking planks have become known, for example, from DE 27 54 226 A, from DE 29 16 826 A, from DE 79 12 134 U1, from DE 198 58 969 A1, from DE 198 58 970 A1 or from DE 102 54 033 A1. In practice, these decking planks are also referred to as steel decks, because they preferably consist of steel, particularly of sheet steel.

In earlier times, a wooden plank was frequently laid down as a bridging deck. However, such wooden planks have only a limited weather resistance, and their non-slip safety,

2013201665 15 Apr 2015

particularly in rain, is not satisfactory. Also, such wooden planks cannot satisfy increased demands with regard to fire safety.

For this reason, it is desirable to be able to use bridging or supplemental decks composed of metal, particularly of steel and/or of aluminum. A particularly advantageous sheet-steel bridging decking plank has become known, for example, from DE 20 2004 021 196 U1. In practice, these decking planks are also referred to as steel planks, because they preferably consist of steel, particularly of sheet steel.

Such bridging decks or supplemental decks must be secured, for safety reasons, to prevent lift-off and lateral displacement. For this purpose, for example, one could use a screw that has a screw head and a threaded shaft, the threaded shaft of which could be inserted, for attachment assembly, through recesses of the scaffolding decks to be secured, which lie one on top of the other at least in partial regions, from above or from below. Subsequently, a nut could be screwed into the threaded shaft and tightened by means of a tool, in order to be able to achieve sufficient security to prevent lateral displacement and lift-off of the bridging deck or supplemental deck, in each instance, relative to at least one second scaffold deck firmly connected with the scaffolding. Assembly and disassembly using such a screw with a locking nut would be comparatively complicated, and acute risk of falling would exist when inserting the screw through from below or when screwing the locking nut, from below, onto the screw inserted through from above. In every case, the deck underside would have to be accessible.

2013201665 15 Apr 2015

A cylindrical pin in combination with a locking cotter pin could also be used as a connection means for securing a bridging deck or supplemental deck to a scaffold deck fixed in place on a scaffolding; this cotter pin is inserted into a transverse hole of the locking pin after the latter has been inserted through the holes of the scaffold decks to be connected. Such a connection would not be free of play, however, so that the bridging deck or supplemental deck could be moved, relative to the scaffold deck that is fixed in place on the scaffolding, both horizontally and vertically, and this would represent a safety risk. Here, too, the deck underside would have to be accessible in every case.

The use of self-locking pins would also be possible, but this method of connection would also have the disadvantage that it would not be possible without play. Furthermore, disassembly would be complicated.

Finally, connections between two scaffold decks using special clamps composed of metal have become known according to DE 20 2008 003 126 U1. However, assembly and disassembly are complicated and not easy to handle. Furthermore, here, too, no connection free of play is possible, and only restricted load-bearing capacity can be achieved.

With the goal of making available an attachment pin for securing at least two scaffold decks to prevent displacement relative to one another, which pin makes possible simple and fast assembly and disassembly, at increased work safety, from above, by hand, and without

2013201665 15 Apr 2015

tools, and which guarantees security against lift-off, in the assembled state, it was proposed, according to DE 203 18 090 U1, that the pin shaft has an elastic and flexible element for engaging behind the recess edge, which element can be inserted through, with elastic deformation, at least at the recess edge of the recess of a first scaffold deck, manually, through the recesses of the scaffold decks to be attached to one another, and which, in the installed state, engages behind the recess edge of the recess of the first scaffold deck. Such an attachment pin can be installed and removed without tools. Also, advantageous possibilities for balancing out tolerance of dimensions of the recesses of the scaffold decks and/or for balancing out different distances of the recess edges of the recesses of the scaffold decks to be secured relative to one another, possibly also caused by unevenness of the scaffold decks and/or their decking surfaces, can be created with attachment pins structured in this manner. Furthermore, such attachment pins can be produced, in simple and cost-advantageous manner, with robustness that satisfies the rough practical conditions in scaffolding construction, and fulfill their function and can be reliably used even when the scaffold decks are dirty. However, when using such attachment pins, it is not possible to achieve play-free connections. Furthermore, these attachment pins can be used only once, at least when connections are required that satisfy the greatest possible safety requirements in scaffolding construction. Finally, the load-carrying capacity of these attachment pins, which consist of plastic, is limited.

The above references to the background art do not constitute an admission that the art forms a part of the

2013201665 15 Apr 2015

common general knowledge of a person of ordinary skill in the art. The above references are also not intended to limit the application of the method and system as disclosed herein

Summary

Disclosed is a scaffolding system in an overlap arrangement comprising:

(a) first and second decking planks for construction scaffolding, respectively, composed of metal, and having first and second decking surfaces, respectively, composed of sheet metal and provided with essentially round passage holes,

wherein at least some of the passage holes of the first and second decking planks, respectively, are delimited by a respective beaded, circumferential hole edge spanning an inside diameter,

wherein each beaded, circumferential hole edge of the beaded, circumferential hole edges is delimited circumferentially by an inside radius, seen in cross-section that contains a passage hole axis, and wherein each of the beaded, circumferential hole edges has a hole edge height which amounts to 3.5 to 4 mm;

wherein the second decking plank is disposed above and overlaps the first decking plank so that the second decking plank engages at least partly over the first decking surface;

(b) a metal locking screw having a thread releasably attaching the first decking plank to the second decking plank secured to prevent relative lateral displacement of the first and second decking planks in a displacement plane parallel to the first and second decking surfaces and

2013201665 15 Apr 2015

secured to prevent lift-off of the first and second decking planks from one another, wherein the thread has a thread root that spans a core diameter, and wherein said thread root has a width, viewed in a direction of a longitudinal screw axis of the locking screw, between adjacent thread flanks, that amounts to about 1.5 to about 2.5 mm, and wherein the thread has a thread pitch that approximately corresponds to the inside radius;

wherein the locking screw has a screw head and a pin shaft, said pin shaft passing through respective first and second passage holes in the first and second decking planks, said first and second passage holes are delimited by a respective beaded, circumferential hole edge spanning an inside diameter, said screw head engaging over and lying against a hole edge of the second passage hole of the second decking plank; and

wherein the locking screw is screwed-in with its thread directly into the first passage hole of the first decking plank without plastic deformation and without elastic widening of the hole edge of the first passage hole and so that the second decking plank and the first decking plank are braced relative to one another with a force and shape fit without play only via the locking screw, without using a nut being screwed onto the locking screw.

Advantageously, the overlap arrangement disclosed may satisfy the greatest safety requirements in scaffolding construction, in which a play-free connection of at least two decking planks may be secured, without the risk of lateral slipping and/or vertical lift-off, and with which installation and removal from above may be possible, easily and without problems, even if no access from below is possible on the underside of the lower decking plank. This

2013201665 15 Apr 2015

may be the case, for example, for single-layer ceiling scaffoldings.

In at least one embodiment, the geometry of the thread of the locking screw is structured to be coordinated with the geometry of the beaded or domed hole edges of the decking planks to be secured, in such a manner that while the locking screw is screwed into the passage hole or the passage holes, essentially no or no plastic deformation comes about and also, essentially no or no elastic widening of the hole edge of the passage holes, in each instance, comes about, and that the decking planks to be secured can be braced or are braced relative to one another using the screwed-in locking screw, with force fit and shape fit. It is understood that during the bracing process, slight elastic deformations or widenings all the way to slight plastic deformations can occur in the hole edge region, by means of screwing or tightening the locking screw, as a function of the torque or tightening torque applied in this connection. However, these slight deformations, to the extent that they occur at all, do not impair the function or the quality of the shape-fit and force-fit connection, in other words they are not relevant for reliable use in practice over an extended period of time.

According to at least one embodiment, it can be provided that the locking screw is screwed, with its thread, not only directly into the said passage hole of the upper, second decking plank, but also directly into the said passage hole of the lower, first decking plank, essentially without or without any plastic deformation and essentially without or without any elastic widening of these two passage holes. In this way, it may be possible to achieve

2013201665 15 Apr 2015

an even better connection, with greater load-bearing capacity, as well as secure locking. For this purpose, the thread of the locking screw can be configured to be correspondingly long or, if applicable, also only in the region of the passage hole, in each instance. In this way, such locking screws can also be used for other bridging applications, for example for securely screwing a separate flooring surface made of metal, having corresponding passage holes, particularly a separate flooring sheet, to one or more of the decking planks, for closing gaps between two overlapping decking planks.

In some embodiments, it is possible to brace the first decking plank and the second decking plank, relative to one another, using only the locking screw, in other words free of any other ancillary attachment means and/or without using a nut screwed onto the locking screw, to prevent lift-off from one another and lateral displacement relative to one another, using the locking screw, with force fit and shape fit. Accordingly, it can be provided that the first decking plank and the second decking plank are braced relative to one another only using the locking screw, in other words free of any other ancillary attachment means and/or without using a nut screwed onto the locking screw, secured to prevent lift-off from one another and lateral displacement relative to one another, with force fit and shape fit.

According to at least one embodiment, it can be provided that the passage holes through which the locking screw projects or into which the locking screw is screwed with its thread span an inside diameter that has essentially or about the same size. In this way, the locking screw can be

2013201665 15 Apr 2015

structured continuously with the same thread, particularly so that no differently great thread diameters have to be present on one and the same locking screw. Furthermore, it then does not matter which of the decking planks forms the lower decking plank and which of the decking planks forms the upper decking plank, so that corresponding handling and installation advantages occur.

According to at least one embodiment, it can be provided that the thread has an outside thread diameter that is slightly, namely only by about 1.5 to 5.0 percent greater than the inside diameter of the particular passage hole into which the locking screw is screwed with its thread, or only by about 1.5 to 5.0 percent greater than the inside diameter of those passage holes into which the locking screw is screwed with its thread. In this way, for one thing, a secure shape-fit and force-fit connection is made possible, and for another, the locking screw can be screwed in and unscrewed without jamming.

According to at least one embodiment, it can be provided that the outside thread diameter of the thread is greater by about 3.0 percent than the inside diameter of the passage hole into which the locking screw is screwed with its thread, or greater by about 3.0 percent than the inside diameter of the particular passage holes into which the locking screw is screwed with its thread. In this way, a further improvement in the sense of the above advantages can be achieved.

According to at least one embodiment, it can be provided that the inside diameter of the passage hole amounts to about 13.0 mm to 14.0 mm, particularly about 13.2 to 13.6

2013201665 15 Apr 2015

mm, and that the outside thread diameter amounts to about 13.7 mm to 14.3 mm, particularly about 14.0 mm. Such a diameter pairing has proven to be particularly advantageous in the above sense when using the decking planks of the patent proprietor, which have successfully proven themselves in practice.

According to at least one embodiment, it can be provided that the thread has a thread pitch that amounts to about 0.25 to 0.35 times, particularly about 0.3 times the inside diameter of the passage hole into which the locking screw is screwed, or the inside diameter, in each instance, of the particular passage holes into which the locking screw is screwed. In this way, a further improvement in the sense of the above advantages can be achieved.

According to at least one embodiment, it can be provided that the beaded hole edges are delimited circumferentially, viewed in a cross-section that contains a passage hole axis, in each instance, with an inside radius, and that the thread has a thread pitch that approximately corresponds to the inside radius or is equal to or slightly greater or slightly less than the inside radius. In this way, a further improvement in the sense of the above advantages can be achieved.

According to at least one embodiment, it can be provided that the thread has a thread pitch of about 3.5 mm to 5.0 mm, particularly of about 4.0 mm. In this way, in combination with the decking planks of the patent proprietor that have proven themselves in practice, a very particularly secure connection can be achieved, whereby the locking screw can be screwed into the passage hole of the

2013201665 15 Apr 2015

decking plank or into the passage holes of the decking plank particularly easily and without jamming, and consequently can be screwed onto and braced with the decking plank or with the decking planks.

In at least one embodiment, the thread has a flank angle that amounts to about 35 degrees to 50 degrees, particularly about 42 degrees.

In some embodiments, the thread can have a core diameter that amounts to about 9 mm to 11 mm, particularly about 10 mm. In this way, the locking screw can be screwed in in particularly simple and easy or jam-free manner, and can also be easily tightened, i.e. without any great expenditure of force, for bracing the decking planks to be secured.

According to at least one embodiment, it can be provided that the thread is a V-shaped thread or a trapezoid thread. In this way, a further improvement in the sense of the above advantages can be achieved.

According to at least one embodiment, it can be provided that the thread has a thread root that spans a or the core diameter, which root has a width between adjacent thread flanks, viewed in the direction of a longitudinal screw axis of the locking screw, which amounts to about 1.5 to 2.5 mm, preferably about 2.0 mm. In this way, a further improvement in the sense of the above advantages can be achieved.

In a at least one embodiment, it can be provided that the hole edges of the passage holes are beaded up all the way

2013201665 15 Apr 2015

to a hole edge height above or below a surface of the sheet metal, and that the screw head of the locking screw has a head height that corresponds approximately to the hole edge height of the hole edges, or that is equal to or less than the hole edge height of the hole edges. In this way, particularly if the locking screw is introduced or screwed into a passage hole with its thread end or insertion end, in the direction of the beading of a passage hole provided with hole edges that are beaded downward, and if the hole edges of adjacent passage holes are beaded upward, the screw head can be accommodated in such a manner that a tripping hazard is avoided or prevented.

According to at least one embodiment, it can be provided that the head height of the screw head of the locking screw amounts to about 3.0 mm to 5.0 mm, particularly about 3.5 to 4.0 mm. In this way, a further improvement in the sense of the above advantages can be achieved.

According to at least one embodiment variant, it can be provided that the screw head has a slit that is U-shaped in cross-section in its head side facing away from the screw-in end of the locking screw; this slit is preferably continuous over the entire head width and can be used to screw in, tighten, and loosen the locking screw again, by means of a screwdriver or similar tool.

According to at least one embodiment, it can be provided that the thread ends at a distance from a or the screw-in end of the locking screw, so that the locking screw has a thread-free insertion end for insertion of the locking screw, in the direction of its longitudinal screw axis, into a passage hole of the passage holes, preferably

2013201665 15 Apr 2015

whereby the thread-free insertion end can be configured in the form of a circular cylinder having an outside diameter, particularly one that can correspond to the core diameter of the thread of the locking screw or that can be smaller than that of the core diameter. This facilitates introduction or screwing in of the locking screw into the passage hole, or the respective passage hole.

The disclosure also relates to construction scaffolding, a work platform, a cantilever or a podium, having an overlap arrangement according to the invention.

1. In some embodiments, the construction scaffolding, the work platform, the cantilever or the podium can be structured or configured in such a manner that
2. a third decking plank composed of metal and a second metal locking screw;

wherein the third decking plank has a third decking surface composed of sheet metal and provided with passage holes, said third decking plank extending at a first height, and wherein the second locking screw has a second screw head and a second pin shaft, said second pin shaft passing through respective third and fourth passage holes of the passage holes in the third and second decking planks, said third and fourth passage holes being delimited by a respective beaded, circumferential hole edge spanning an inside diameter, said second screw head lying opposite a hole edge of the fourth passage hole of the second decking plank;

wherein the first decking plank extends at approximately the first height at a horizontal distance from the third decking plank;

2013201665 15 Apr 2015

wherein the second decking plank bridges a space between the first decking plank and the second decking plank so that the decking surface engages over the third decking surface; and

wherein the second decking plank is braced together with the first decking plank, with a force and shape fit without play, only via the locking screw, without using a nut being screwed onto the locking screw, and with the third decking plank, with a force and shape fit without play, only via the second locking screw, without using a nut being screwed onto the second locking screw. decking plank, using a corresponding or same locking screw, with force fit and shape fit, preferably without play.

Brief Description of the Drawings

Further characteristics, advantages and aspects can be derived from the following description part, in which at least one embodiment of the invention is described with reference to the figures.

It is understood that a person skilled in the art can combine the above and also the following characteristics and measures, within the scope of implementability, individually or in groups, in any desired manner.

The figures show:

Fig. 1 a three-dimensional representation of an embodiment of a system scaffolding having two overlap arrangements;

2013201665 15 Apr 2015

- Fig. 2 a three-dimensional representation of an embodiment of an overlap arrangement having two decking planks in the form of scaffold decks;
- Fig. 3 a three-dimensional representation of an embodiment of a cascade overlap arrangement of more than two decking planks that lie one on top of the other, of which immediately adjacent decking planks, in each instance, are braced relative to one another using a locking screw, in each instance, secured to prevent lateral displacement and to prevent lift-off;
- Fig. 4 another embodiment of an overlap arrangement having two overlapping decking planks, in cross-section that contains the longitudinal axis of a locking screw and is configured perpendicular to the longitudinal axes of the decking planks;
- Fig. 5 a greatly enlarged detail of the overlap arrangement according to Figure 4 in the region of the screw-in end of the locking screw;
- Fig. 6 a three-dimensional representation of an embodiment of a locking screw;
- Fig. 7 a side view of the locking screw according to Figure 6;
- Fig. 8 a side view of the locking screw rotated by 90 degrees as compared with the side view according to Figure 7;

2013201665 15 Apr 2015

Fig. 9 a top view of the screw head of the locking screw according to Figure 8;

Fig. 10 a longitudinal section of the locking screw along the section lines 10-10 in Figure 8;

Fig. 11 a greatly enlarged detail of the longitudinal section of the locking screw in the region of the section of the locking screw indicated with a circle in Figure 10.

Detailed Description

Fig. 1 shows a system scaffolding 34 in a setup situation with two scaffolding parts 57 and 58. The two scaffolding parts 57, 58 are set up, in each instance, along and adjacent to a building wall 69 of a building. The building wall comprises two wall parts 67, 68 that stand perpendicular to one another, and a wall part 74 formed between them. The wall part 74 forms a building corner transition with a building corner 70 structured at a slant of 45 degrees relative to the side building walls or wall parts 67, 68.

The system scaffolding 34 is composed of posts 59 that carry known, essentially flat perforated disks 60 spaced apart from one another at a distance that corresponds to the raster dimension of the scaffolding system. Between the posts 59, horizontal rods 62, 62.1, diagonal rods 63, and horizontal support bars 64 can be attached to the perforated disks 60, using wedge heads 61 that are also called connection heads. For this purpose, wedges 65 penetrate the perforated disks 60 and the wedge heads 61. The perforated disks 60 preferably have eight perforations, which are each disposed at an angle of about 45 degrees

2013201665 15 Apr 2015

relative to one another, through which the wedges 65 extend in the assembled, wedged state, and impart a specific orientation to the connecting heads 61 clamped in place on them, with scaffolding elements that are attached to them, preferably by means of welding. The horizontal support bars 64 preferably have a profile that is open toward the top and U-shaped in cross-section, which profile is provided with profile crosspieces that project upward. Suspension aids 71, for example with profile crosspieces that project upward. Suspension aids 71, for example in the form of suspension claws, can be laid onto the upper contact edges of the profile crosspieces, which aids can preferably be attached to face sides of the scaffold decks 23 that have work surfaces or decking surfaces 25. In the exemplary embodiment shown, two scaffold decks 23, in each instance, are disposed next to one another with opposite longitudinal face sides. It is understood, however, that the width of the scaffolding part 57, 58, in each instance, respectively the width of the horizontal bars, can be selected in accordance with the requirements, in each instance, also in such a manner that it can be structured to be adapted to only one scaffold deck 23 or also to more than two scaffold decks that lie next to one another. In the aforementioned manner, a stable system scaffolding 34 that meets the practical requirements in particular manner can be constructed. It is understood, however, that the invention can also be advantageously used in connection with other system scaffoldings or other scaffoldings.

In the event that one of the two scaffolding parts 57 or 58 were to be set up in such a manner that it overlaps the other scaffolding part 58 or 57 on the face side, a gap would occur between the slanted wall part 74 of the corner

2013201665 15 Apr 2015

70 and one of the scaffolding parts 57 or 58, which gap would not be sufficiently secured. Furthermore, the scaffolding part 57 or 58 in question would then have a comparatively great distance from the slanted wall part 74 of the corner 70, which would make work on this wall part 74 impossible or only possible under difficult conditions.

For this reason, a further scaffold deck 22 is provided as a bridging deck or supplemental deck, which is also referred to as a second or upper scaffold deck. This scaffold deck 22 is disposed, in the exemplary embodiment, approximately parallel to the slanted wall part 74 of the corner 70 and adjacent to it. In this connection, the scaffold deck 22, in partial regions, here with one of its two end regions, in each instance, lies on the surface of a scaffold deck 23, in each instance, of the scaffold decks 23, 23, disposed at a horizontal distance from one another, at about the same height, and specifically, here, in the uppermost level of the scaffolding parts 57 and 58.

The scaffold decks 22 and 23 consist, in each instance, of sheet steel. At the longitudinal edges of the scaffold decks 22, 23, longitudinal edge rails 86.1, 86.2; 90.1, 90.2, formed by means of bending, are provided, in each instance. The longitudinal edge rails 86.1, 86.2; 90.1, 90.2 have a reinforcement profile 88.1, 88.2; 92.1, 92.2, in each instance, formed by means of bending, extending in the longitudinal direction. The reinforcement profile 88.1, 88.2; 92.1, 92.2, in each instance, forms a lower rail, in each instance. The reinforcement profile of the lower rail 88.1, 88.2; 92.1, 92.2 extends, in each instance, essentially over the entire length of the scaffold deck 22, 23, in each instance, parallel to its

2013201665 15 Apr 2015

longitudinal axis. The two edge rails 90.1, 90.2 of the second or upper scaffold deck 22, in other words here the bridging deck or supplemental deck 22 or of the steel plank 22 have a height 91 that amounts to about 45 mm to 46 mm, for example. The two edge rails 86.1, 86.2 of the first or lower scaffold deck 23 or of the steel plank 23 have a greater height 87, as compared with the height 91 of the edge rails 90.1, 90.2 of the second or upper scaffold deck 22, which height amounts to about 76 mm to 77 mm, for example. The upper edge of the hole edges 28.1 or 32.1 of the hole edges 27.1 or 32.1, which is beaded or domed upward, is disposed slightly below the upper edge of the edge rail 90.1, 90.2 or 86.1, 86.2, in each instance, for example by about 0.5 mm below.

The scaffold decks 22, 23, in each instance, have end profiles 89, 93 composed of metal, firmly connected with the decking surface 24, 25 and firmly connected with the longitudinal edge rails 86.1, 86.2; 90.1, 90.2, on their two face sides that face away from one another. The end profiles 89, 93 extend essentially over the entire width of the scaffold deck 22, 23, in each instance. The end profiles 89, 93, preferably configured as U profiles, have a height, in each instance, that corresponds to the clear width between the underside of the sheet metal 84 that forms the decking surface 24, 25, and the reinforcement profile or lower rail 88.1, 88.2; 92.1, 92.2, in each instance. The end profiles 89, 93 and the longitudinal edge rails 86.1, 86.2; 90.1, 90.2, in each instance, form a frame composed of metal. On the scaffold deck 23, suspension aids 71 in the form of suspension hooks or suspension claws composed of metal are attached to the end profile 89, in each instance, preferably by means of

2013201665 15 Apr 2015

welding, which aids are disposed at a transverse distance from one another. A scaffold deck 23 equipped in this manner is also referred to, in practice, as a steel plank. In contrast to this, the scaffold deck 22 used as a bridging scaffold deck or supplemental scaffold deck is not equipped with any special suspension aids. Accordingly, no suspension claws or similar suspension aids are provided on its end profiles 93. Such a scaffold deck 22 is also referred to as a steel plank in practice.

The scaffold decks 22, 23, in each instance, have a decking surface 24, 25 composed of sheet metal 84, preferably composed of sheet steel, which is provided, essentially distributed over the entire decking surface 24, 25, with essentially circular passage holes 27, 28. The passage holes 27, 28 are therefore configured as circular holes 39, 40. The passage holes 27, 28 form perforations of the decking surfaces 24, 25 of the scaffold decks 22, 23, in each instance. Each scaffold deck 22, 23 has a plurality of passage holes 27, 28. The passage holes 27, 28, in each instance, span an inside diameter 36 that has essentially the same or about the same size, and are delimited, in each instance, by a beaded or domed, circumferential hole edge 28; 28.1, 28.2; 32; 32.1, 32.2. The inside diameter 36 amounts to about 13.6 mm in the preferred exemplary embodiments shown, but can also be smaller by up to about 0.4 mm. The hole edge 28.1; 32.1 of part of these passage holes 27.1; 31.1 is beaded or domed upward, and the hole edge 28.2; 32.2 of part of these passage holes 27.2; 31.2 is beaded or domed downward. In other words, a plurality of the passage holes 27.1, 31.1 is provided with hole edges 28.1, 32.1 that are beaded or domed upward from the decking surface 24, 25, in each instance, and a further plurality

2013201665 15 Apr 2015

of the passage holes 27.2, 31.2 is provided with hole edges 28.2, 32.2 that are beaded or domed downward from the decking surface 24, 25, in each instance. In this connection, the passage holes 27.1, 31.1 having hole edges 28.1, 31.1 that are beaded or domed upward form anti-slip security, and the passage holes 27.2, 31.2 having hole edges 28.2, 31.2 that are beaded or domed downward form drain openings for fluids, such as rain water or paint and the like.

To secure the scaffold decks 22 shown in Figure 1, which serve as a bridging deck or supplemental deck, relative to the two scaffold decks 23 that carry them, to prevent displacement in a horizontal displacement plane 21 or one that runs parallel to their decking surfaces 25 or laterally, the upper scaffold deck 22, in each instance, is attached to the scaffold deck 23 of the scaffolding parts 57 and 58, in each instance, here the deck that lies on the outside, in each instance, using a locking screw 20 according to the invention.

Figure 2 shows an overlap arrangement 30 having two decking planks 22, 23 in the form of scaffold decks, for example in the region of the corner transition according to Figure 1. In this connection, an upper decking plank 22 in the form of a bridging or supplemental scaffold deck, also referred to as a second decking plank, lies on the surface, structured as a decking surface 25 of a lower decking plank 23 in the form of a scaffold deck of a free-standing scaffolding, also referred to as a first decking plank 23, with one of its end regions, overlapping it. The lower or first scaffold deck 23 is attached to the support rails 64 by means of known attachment means 71, for example using

2013201665 15 Apr 2015

the suspension hooks or suspension claws shown. The said second or upper decking plank 22 is braced with the first decking plank 23, using a locking screw 20 according to the invention, which is shown in longitudinal section here, which is screwed not only into a passage hole 27.2 of the second or upper decking plank 22 but also into a passage hole 31.1 of the first or lower decking plank 23, secured relative to the first decking plank 23 that carries it, to prevent lateral displacement in the displacement plane 21 and to prevent lift-off. In Figure 2, it is therefore shown, using the example of two scaffold decks 22 and 23, how one of the bridging or supplemental scaffold decks 22 can be secured relative to one of the scaffold decks 23, using a locking screw 20, to prevent lateral displacement in the displacement plane 21, and to prevent lift-off in a direction perpendicular to the displacement plane 21, and away from the scaffold deck 23. In this connection, the bridging or supplemental scaffold deck 22 lies on the surface of the lower scaffold deck 23 in one of its end regions, and at a slant to the scaffold deck 23, in its end region. The locking screw 20 projects through a passage hole 27.1 of the upper scaffold deck 22, which hole has hole edges 28.1 beaded or domed downward below the decking surface 24, while the locking screw 20 projects through a passage hole 31.2 of the lower scaffold deck 23, which has hole edges 32.1 beaded or domed upward above the decking surface 25 of this lower scaffold deck 23. In this connection, the locking screw 20 is screwed not only directly into the passage hole 27.1 of the upper scaffold deck 22, but also directly into the passage hole 31.2 of the lower scaffold deck 23, specifically without plastic deformations, in each instance, and without elastic widening of the passage hole 27.1, 31.2, in each instance.

2013201665 15 Apr 2015

By means of the locking screw screwed into the passage holes 27.1, 31.2, the two scaffold decks 22 and 23 are braced against one another without play, as well as with force fit and shape fit, whereby they are secured, by means of the locking screw 20, to prevent displacement in the said displacement plane 21 and to prevent lift-off from one another. It is understood that the locking screw 20 can also be guided through the passage holes 27, 31 in any other desired manner. For example, the locking screw 20 can project through a passage hole 27.2 of the upper scaffold deck 22, which hole has hole edges 28.2 that are beaded or domed upward above the decking surface 24, while the locking screw 20 can project through a passage hole 27.1 of the lower scaffold deck 23, which hole has hole edges 32.2 that are beaded or domed downward below the decking surface 25 of this scaffold deck 23. It is furthermore understood that the locking screw 20 can project, both in the case of the scaffold deck 22 and in the case of the scaffold deck 23, through their passage holes 27.2, 31.2 that have hole edges 28.2, 32.2 that are beaded or domed downward below the decking surfaces 24, 25, in each instance, or through their passage holes 27.1, 31.1 that have hole edges 28.1, 32.1 that are beaded or domed upward above the decking surfaces 24, 25, in each instance. In this manner, flexible securing of two scaffold decks 22, 23 relative to one another, at different attachment positions, can be implemented. This is also supported, in the exemplary embodiment, by the plurality of passage holes 27, 28 disposed essentially over the entire decking surface 24, 25 of the scaffold deck 22, 23, in each instance, with the exception of edge regions, closely adjacent to one another at a small distance.

2013201665 15 Apr 2015

As is evident from Figure 3, a plurality of more than two scaffold decks 22, 22.1, 22.2, which can serve as bridging or supplemental scaffold decks, in the form of a cascade overlap arrangement 50, can be secured relative to one another and relative to at least one scaffold deck 23, using locking screws 20 according to the invention. In this connection, two of the scaffold decks 22.2, 23; 22.1, 22, in each instance, can be secured relative to one another by means of at least one locking screw 20, in each instance, to prevent lateral displacement and lift-off.

In the exemplary embodiment of an overlap arrangement 30 shown in Figure 4, the locking screw 20 is screwed not only directly into the passage hole 27.2 of the upper scaffold deck 22 that is circumferentially delimited by a hole edge 28.2 that is beaded or domed downward, but also directly into the passage hole 31.2 of the lower scaffold deck 23 that is also circumferentially delimited by a hole edge 32.2 that is also beaded or domed downward, specifically without any plastic deformations, in each instance, and without elastic widening of the passage hole 27.2, 31.2, in each instance. The screw head 26 of the locking screw 20 engages over the particular passage hole 27.2 of the upper scaffold deck 22 into which the locking screw 20 is screwed, and the said screw head 26 lies against the surface between two adjacent hole edges 28.1, 28.1 of passage holes 27.1, 27.1 of the sheet metal 84, which are beaded or domed upward, in each instance. The screw head 26 has a head height 78 that corresponds to the hole edge height 72 of the hole edges 28, 31 that are beaded or domed upward, above the said surface of the sheet metal 84, so that no tripping hazard can occur. The hole edge height 72 amounts, for example, to 3.5 to 4.0 mm. By means of the

2013201665 15 Apr 2015

locking screw 20 screwed into the passage holes 27.2, 31.2, the two scaffold decks 22 and 23 are braced against one another without play, and with force fit and shape fit, whereby they are secured to prevent displacement in the displacement plane 21 and to prevent lift-off from one another, by means of the locking screw 20.

As can be seen well in the greatly enlarged representation in Figure 5, here the last thread channel 97 of the locking screw 20 screwed into the passage hole 31.2 of the lower scaffold deck 23 engages, with the thread flank 94.2 of the thread 35, into the lower ring face edge of the hole edge 32.2 of this passage hole 31.2, which is beaded or domed downward, so that in connection with the screw head 26 that engages over the passage hole 27.1 of the upper scaffold deck 22 laterally, a force-fit and shape-fit connection and bracing of the two scaffold decks 22 and 23 with one another can be achieved or has been achieved. As can also be seen well in Figure 5, here the next-to-last thread channel 96 of the threaded screw lies against the hole edge 32.2 that is beaded or domed upward, with the thread tip of the thread 35, against the inside surface that is circumferentially rounded with an inside radius 55. The geometry of the thread 35 of the locking screw 20 is structured to be adapted to the geometry of the hole edges that are beaded or domed upward, in such a manner that no elastic or plastic deformation of the hole edge of these passage holes can occur while the locking screw 20 is being screwed into the passage holes.

The locking screw 20 according to the invention is shown separately in Figures 6 to 11. The locking screw 20 consists of metal, preferably of steel. The locking screw

2013201665 15 Apr 2015

20 has, as essential elements, a screw shaft 29 having a thread 35, and a screw head 26. The screw shaft 29 extends, in a longitudinal direction, parallel to a longitudinal axis 33 of the locking screw 20. The screw head 26 is disposed at one end of the locking screw 20, and extends perpendicular to the longitudinal axis 33 or to the screw head 29, radially outward, all the way beyond the outside diameter 42 of the thread 35. The screw head 26 is structured as a flat head with a circular cylinder. It has a head diameter or outside diameter 75. The head diameter or outside diameter amounts, for example, to about 3.5 to 4.0 mm. The screw head 26 is provided, at its head side 79 facing away from the screw-in end 56 or the insertion end 51 of the screw shaft 29, with a slit 81 that is open to the outside and U-shaped in cross-section. The slit 81 has a slit width 81.1 and a slit height 81.2. The slit width 81.1 amounts, for example, to about 5.0 mm, and the slit height 81.2 amounts, for example, to about 2.0 to 2.5 mm.

The length 77 of the locking screw 20 amounts, for example, to about 60 mm to 62 mm. The length 29.1 of the screw shaft 29 amounts, for example, to about 57 mm. The thread 35 of the locking screw 20 extends, in the longitudinal direction, not over the entire length 29.1 of the screw shaft 29, but rather only over a partial length or thread length 41, for example of about 49 mm. The thread 35 ends, viewed in the direction of the screw head 26, at a distance before the screw head 26, and ends, viewed in the opposite direction, at a distance 51.1 before the other end of the screw shaft 29. This distance 51.1 amounts, for example, to about 4.0 mm. In this manner, an insertion end 51 that does not have a thread is formed. This has an insertion length 51.1 that corresponds to the said distance. The

2013201665 15 Apr 2015

insertion end of the screw shaft 29 has a thickness 45 or an outside diameter that preferably corresponds to the core diameter 47 of the thread 35. The core diameter 47 of the thread 35 preferably amounts to 10.0 mm.

The thread 35 is a single-channel right-hand thread in the form of a trapezoid thread. It is understood, however, that the thread can also be a left-hand thread. The thread 35 is a non-self-tapping thread. The thread 35 has a flank angle 44 between adjacent thread flanks 94.1, 94.2. The flank angle preferably amounts to 42 degrees. The thread 35 has a thread pitch 43 that preferably amounts to 4.0 mm. The thread 35 has a thread depth 48.1 that preferably amounts to 2.0 mm. The thread 35 is delimited, radially toward the inside or toward the longitudinal screw axis 33, by a level thread root 48 that runs parallel to the longitudinal screw axis 29, and is delimited, radially toward the outside, by a thread tip 95 that is delimited by an outer surface that runs parallel to the longitudinal screw axis 33. The width 49 of the thread root 48 between two thread flanks 94.1 and 94.2 preferably amounts to 2.0 mm. It is understood that the thread root can also be configured differently, in other words can have a concave curvature, for example.

In the claims which follow and in the preceding description, except where the context requires otherwise due to express language or necessary implication, the word "comprise" or variations such as "comprises" or "comprising" is used in an inclusive sense, i.e., to specify the presence of the stated features but not to preclude the presence or addition of further features in various embodiments of the method and apparatus.

REFERENCE SYMBOL LIST

20	locking screw/ attachment pin	32.2	hole edge of 31.2
21	displacement plane	33	longitudinal axis of 20
22	second scaffold deck/ bridging or supplemental scaffold deck/decking plank	34	system scaffolding/ construction scaffolding
22.1	scaffold deck/decking plank	35	thread
22.2	scaffold deck/decking plank	36	inside diameter of 27, 28
23	first scaffold deck/ decking plank	37	inside contour of 32
24	decking surface of 22	38	inside contour of 28
25	decking surface of 23	39	circular hole
26	attachment head/ screw head	40	circular hole
27	passage hole of 22	41	thread length of 35
27.1	passage hole of 22	42	outside thread diameter of 35
27.2	passage hole of 22	43	thread pitch of 35
28	hole edge of 27	44	flank angle of 35
28.1	hole edge of 27.1	45	thickness of 29
28.2	hole edge of 27.2	46	outside diameter of 29
29	pin shaft/screw shaft	47	core diameter of 35
29.1	length of 29	48	thread root of 35
30	overlap arrangement	48.1	thread depth of 35
31	passage hole of 23	49	width
31.1	passage hole of 23	50	cascade overlap arrangement
31.2	passage hole of 23	51	free insertion end of 20
32	hole edge of 31	51.1	distance/length of 51
32.1	hole edge of 31.1		

2013201665 15 Apr 2015

52	passage hole axis of 27	81	slit
53	passage hole axis of 31	81.1	slit width
		81.2	slit depth
54	inside radius of 28	82	distance
55	inside radius of 32	83	outside diameter of 51
56	screw-in end of 20	84	sheet metal
57	scaffolding part	85	thickness of 24, 25; 84
58	scaffolding part	86.1	edge rail of 23
59	post	86.2	edge rail of 23
60	perforated disk	87	height of 86.1, 86.2
61	wedge head	88.1	reinforcement profile/ lower rail of 86.1
62	horizontal rod	88.2	reinforcement profile/ lower rail of 86.2
62.1	horizontal rod	89	end profile of 23
63	diagonal rod	90.1	edge rail of 22
64	horizontal support bar	90.2	edge rail of 22
65	wedge	91	height of 90.1, 90.2
67	wall part	92.1	reinforcement profile/ lower rail of 90.1
68	wall part	92.2	reinforcement profile/ lower rail of 90.2
69	wall	93	end profile of 22
70	corner	94.1	thread flank of 35
71	suspension aid/ suspension hook/ suspension claw	94.2	thread flank of 35
72	hole edge height	95	thread tip of 35
73	surface	96	next-to-last thread channel
74	wall part	97	last thread channel
75	outside diameter/ head diameter of 26		
76	contact edge of 26		
77	length of 20		
78	head height of 26		
79	head side		

2013201665 15 Apr 2015

CLAIMS

1. A scaffolding system in an overlap arrangement
5 comprising:
(a) first and second decking planks for construction
scaffolding, respectively, composed of metal, and
having first and second decking surfaces, respectively,
composed of sheet metal and provided with essentially
.0 round passage holes,
wherein at least some of the passage holes of the
first and second decking planks, respectively, are
delimited by a respective beaded, circumferential hole
edge spanning an inside diameter,
.5 wherein each beaded, circumferential hole edge is
delimited circumferentially by an inside radius, seen
in cross-section that contains a passage hole axis, and
wherein each of the beaded, circumferential hole edges
has a hole edge height which amounts to 3.5 to 4 mm;
:0 wherein the second decking plank is disposed above
and overlaps the first decking plank so that the second
decking plank engages at least partly over the first
decking surface;
(b) a first metal locking screw having a thread
25 releasably attaching the first decking plank to the
second decking plank secured to prevent relative
lateral displacement of the first and second decking
planks in a displacement plane parallel to the first
and second decking surfaces and secured to prevent
30 lift-off of the first and second decking planks from
one another, wherein the thread has a thread root that
spans a core diameter, and wherein said thread root has

2013201665 15 Apr 2015

5 a width, viewed in a direction of a longitudinal screw axis of the locking screw, between adjacent thread flanks, that amounts to about 1.5 to about 2.5 mm, and wherein the thread has a thread pitch that approximately corresponds to the inside radius;

.0 wherein the locking screw has a screw head and a pin shaft, said pin shaft passing through respective first and second passage holes in the first and second decking planks, said first and second passage holes are delimited by a respective beaded, circumferential hole edge spanning an inside diameter, said screw head engaging over and lying against a hole edge of the second passage hole of the second decking plank; and

.5 wherein the locking screw is screwed-in with its thread directly into the first passage hole of the first decking plank without plastic deformation and without elastic widening of the hole edge of the first passage hole and so that the second decking plank and the first decking plank are braced relative to one
:0 another with a force and shape fit without play only via the locking screw, without using a nut being screwed onto the locking screw.

- 25 2. The scaffolding system according to claim 1, wherein the thread has an outside thread diameter that is about 1.5 to about 5.0 percent greater than an inside diameter of each of the first and second passage holes.
- 30 3. The scaffolding system according to claim 1, wherein the thread has an outside thread diameter that is about 3.0 percent greater than an inside diameter of each of the first and second passage holes.

2013201665 15 Apr 2015

4. The scaffolding system according to claim 1, wherein an inside diameter of each of the first and second passage holes amounts to about 13.0 mm to 14.0 mm and an outside thread diameter of the thread amounts to about 13.7 mm to 14.3 mm.
5. The scaffolding system according to claim 1, wherein an inside diameter of each of the first and second passage holes amounts to about 13.2 to about 13.6 mm and the outside thread diameter of the thread amounts to about 14.0 mm.
6. The scaffolding system according to claim 1, wherein the thread has a thread pitch that amounts to about 0.25 to about 0.35 times the inside diameter of each of the first and second passage holes.
7. The scaffolding system according to claim 1, wherein the thread has a thread pitch that amounts to about 0.3 times an inside diameter of each of the first and second passage holes.
8. The scaffolding system according to claim 1, wherein the thread has a thread pitch that amounts to about 3.5 mm to about 5.0 mm.
9. The scaffolding system according to claim 1, wherein the thread has a thread pitch that amounts to about 4.0 mm.
10. The scaffolding system according to claim 1, wherein the thread has a flank angle that amounts to about 35 degrees to about 50 degrees.

2013201665 15 Apr 2015

11. The scaffolding system according to claim 1, wherein the thread has a flank angle that amounts to about 42 degrees.

5

12. The scaffolding system according to claim 1, wherein the core diameter amounts to about 9 mm to about 11 mm.

.0

13. The scaffolding system according to claim 1, wherein the width of the thread root amounts to about 2 mm.

14. The scaffolding system according to claim 1, further comprising a third decking plank composed of metal and a second metal locking screw;

.5

wherein the third decking plank has a third decking surface composed of sheet metal and provided with passage holes, said third decking plank extending at a first height, and wherein the second locking screw has a second screw head and a second pin shaft, said second pin shaft passing through respective third and fourth passage holes of the passage holes in the third and second decking planks, said third and fourth passage holes being delimited by a respective beaded, circumferential hole edge spanning an inside diameter, said second screw head lying opposite a hole edge of the fourth passage hole of the second decking plank;

:0

25

wherein the first decking plank extends at approximately the first height at a horizontal distance from the third decking plank;

30

wherein the second decking plank bridges a space between the first decking plank and the second decking plank so that the decking surface engages over the third decking surface; and

2013201665 15 Apr 2015

5

wherein the second decking plank is braced together with the first decking plank, with a force and shape fit without play, only via the first locking screw, without using a nut being screwed onto the first locking screw, and with the third decking plank, with a force and shape fit without play, only via the second locking screw, without using a nut being screwed onto the second locking screw.

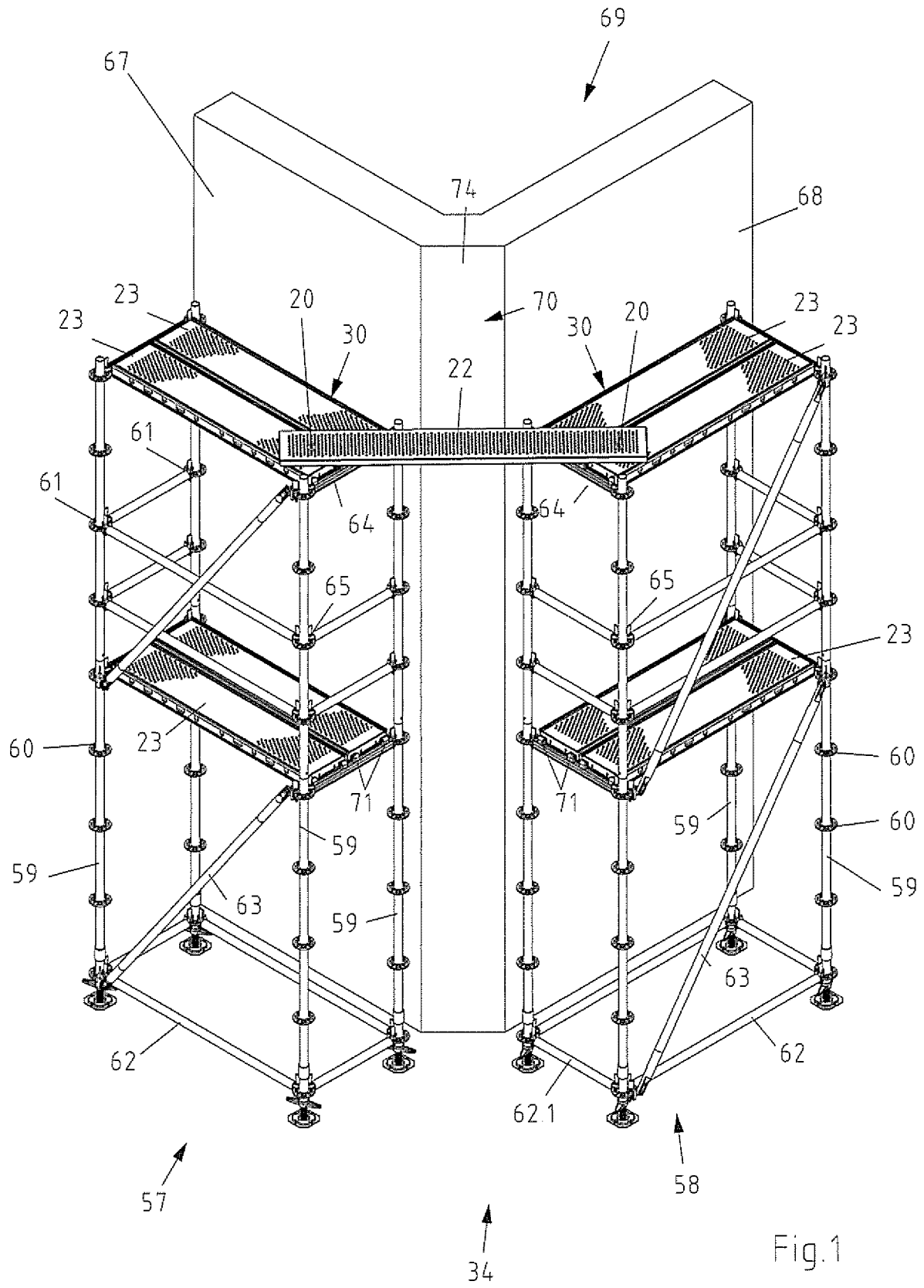

Fig.1

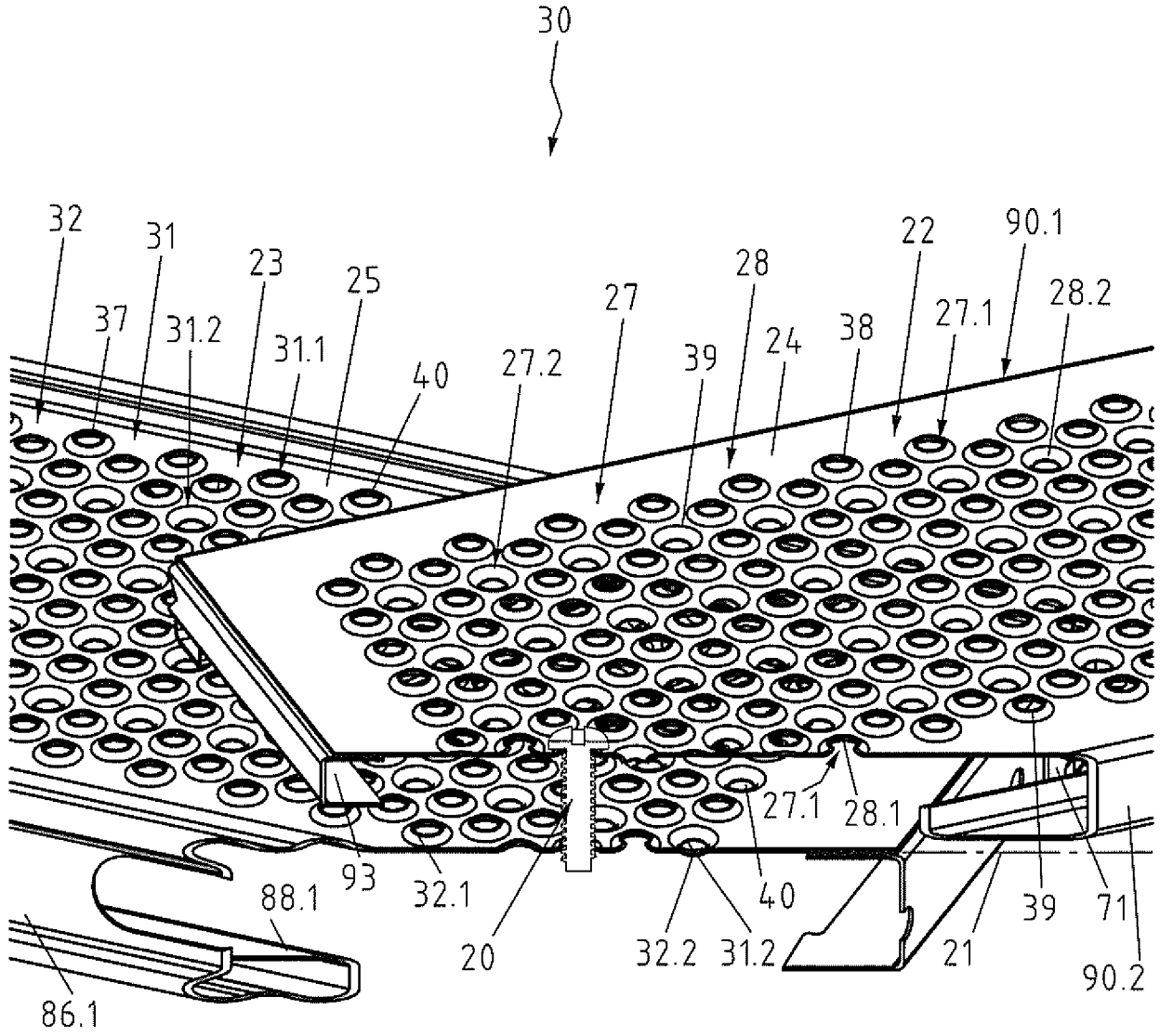

Fig. 2

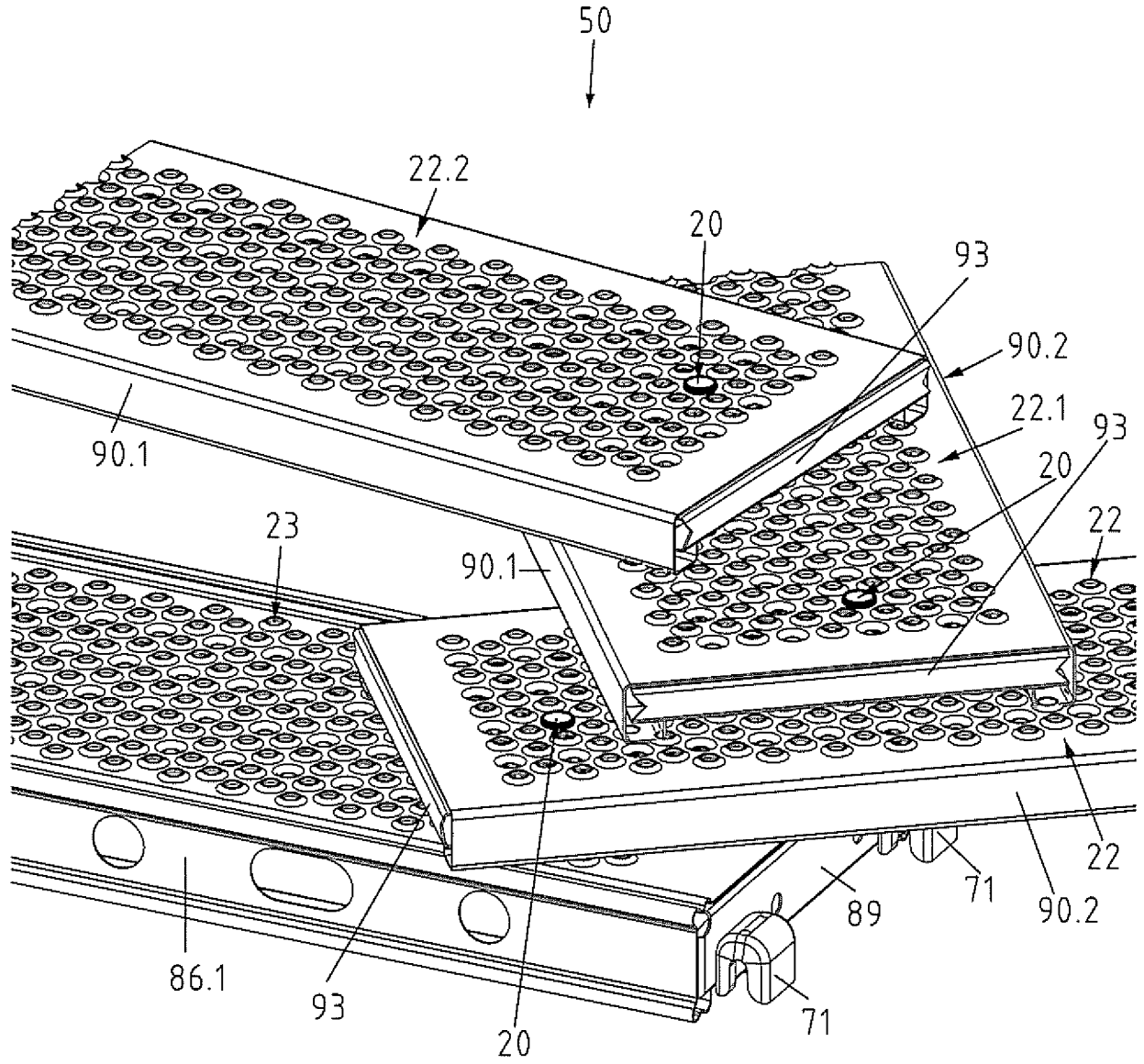

Fig. 3

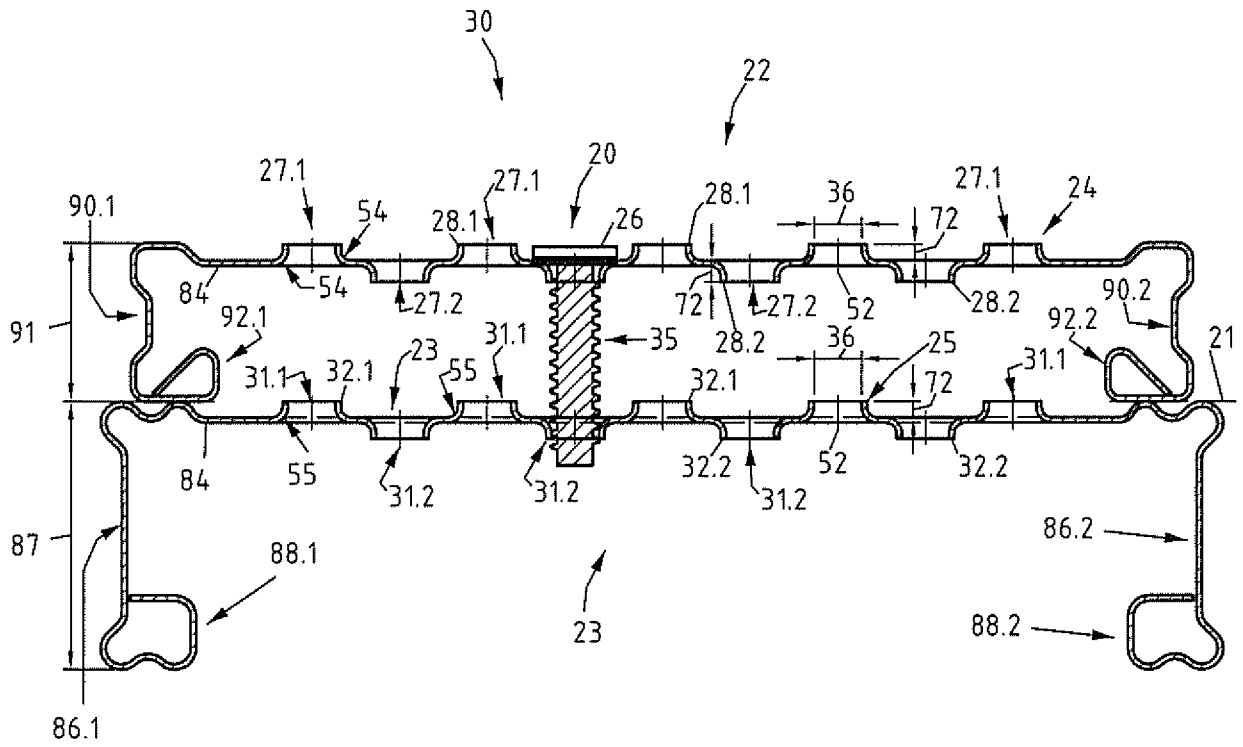

Fig. 4

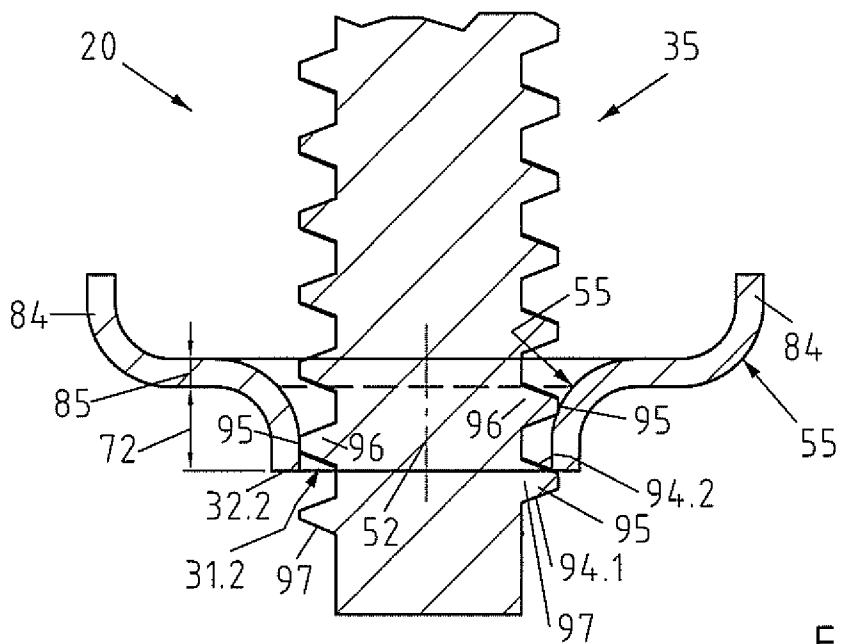

Fig. 5

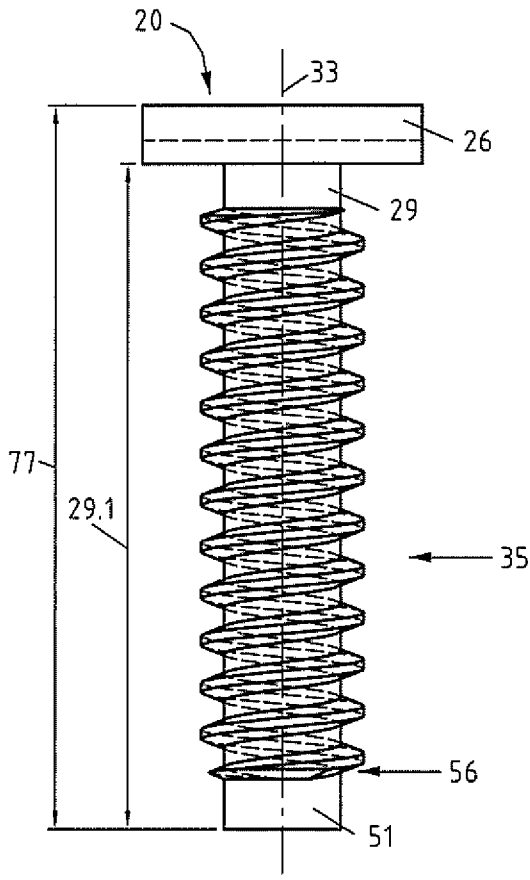

Fig. 7

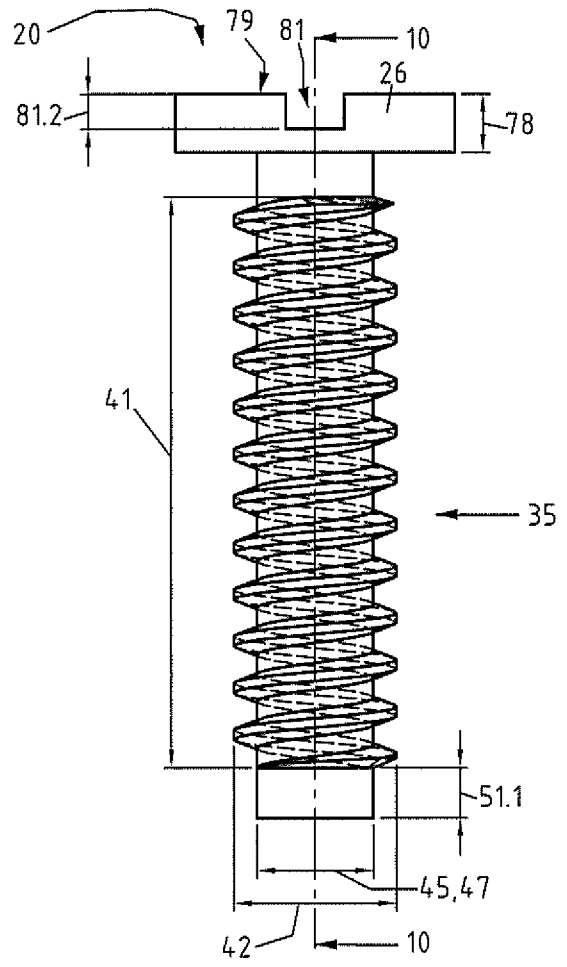

Fig. 8

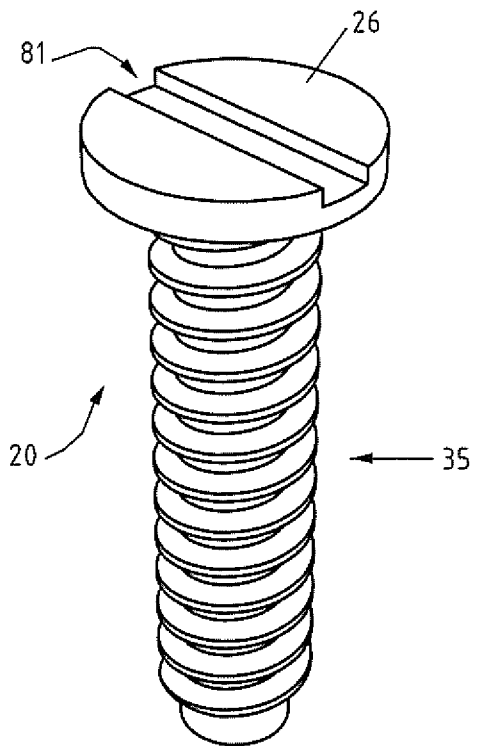

Fig. 6

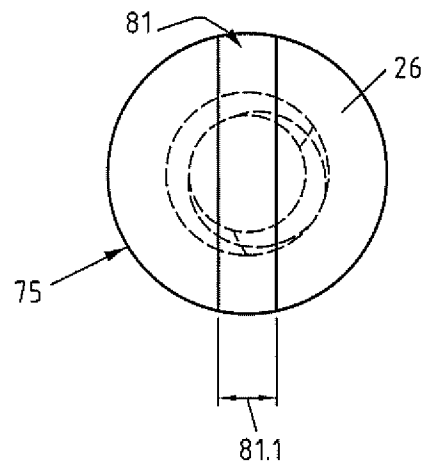

Fig. 9

