

(19)



(11)

EP 1 925 409 B1

(12)

EUROPEAN PATENT SPECIFICATION

(45) Date of publication and mention of the grant of the patent:
31.03.2010 Bulletin 2010/13

(51) Int Cl.:
B26F 1/44 (2006.01)

(21) Application number: **07254355.6**

(22) Date of filing: **02.11.2007**

(54) **Die board for a rotary die and method for making such a die**

Trägerplatte für eine rotierende Stanzmatrize und Verfahren zu dessen Herstellung

Plaque d'estampage rotative et son procédé de fabrication

(84) Designated Contracting States:
AT BE BG CH CY CZ DE DK EE ES FI FR GB GR HU IE IS IT LI LT LU LV MC MT NL PL PT RO SE SI SK TR

- **Lanier, Ronald A**
Florence SC 29501 (US)
- **Helms, Charles F Jr.**
Florence SC 29501 (US)
- **Rhodes, David W**
Florence SC 29501 (US)

(30) Priority: **02.11.2006 US 864021 P**
01.11.2007 US 933486

(74) Representative: **Jones, John Bryn et al**
Withers & Rogers LLP
Goldings House
2 Hays Lane
London
SE1 2HW (GB)

(43) Date of publication of application:
28.05.2008 Bulletin 2008/22

(73) Proprietor: **Sonoco Development, Inc.**
Hartsville,
South Carolina 29550 (US)

(56) References cited:
GB-A- 1 221 539 US-A- 5 143 768
US-A1- 2001 035 071 US-A1- 2004 065 388

(72) Inventors:
 • **Gore, Bennett C**
Hartsville SC 29550 (US)

EP 1 925 409 B1

Note: Within nine months of the publication of the mention of the grant of the European patent in the European Patent Bulletin, any person may give notice to the European Patent Office of opposition to that patent, in accordance with the Implementing Regulations. Notice of opposition shall not be deemed to have been filed until the opposition fee has been paid. (Art. 99(1) European Patent Convention).

Description

BACKGROUND OF THE INVENTION

- 5 **[0001]** The present disclosure relates generally to rotary die boards.
[0002] For many years, rotary dies have been constructed by inserting the die tools (e.g., steel rules for scoring, perforating, and/or cutting, embossing tools, ejection rubbers, etc.) into slots formed in a substrate. The substrate is an arcuate structure, referred to as a die board. US2001/0035071 upon which the preamble is based discloses a die board including a plurality of core layers constructed of a natural wood veneer. GB1221539 discloses die boards made from various materials. US5143768 discloses a die board including a rigid core of a plastics material.

BRIEF SUMMARY OF THE DISCLOSURE

- 15 **[0003]** The present disclosure relates to an arcuate die board formed as a multi-layered paperboard structure. The die board is initially produced as a full cylindrical paperboard tube, which is subsequently cut lengthwise to form two or more part-cylindrical portions each of which can be used to fabricate a die board. The die board is then cut to form the slots for the die tools.
- [0004]** The multi-layered paperboard tube can be spirally wound, convolutedly wound, or formed by a linear draw process.
- 20 **[0005]** In one embodiment, the die board comprises an arcuate part-cylindrical die board formed by a part-cylindrical wall having an outer part-cylindrical surface and an inner part-cylindrical surface, and a plurality of slots formed in the outer part-cylindrical surface of the wall for receiving die tools, wherein the part-cylindrical wall is formed at least predominantly of paperboard plies adhesively laminated together. By "predominantly" is meant that more than 50% of the radial thickness of the die board is made up of paperboard plies. In advantageous embodiments, the die board is free of any wood layer(s) and is free of any phenolic-treated paperboard plies.
- 25 **[0006]** In another embodiment, the die board is made up substantially entirely of a plurality of paperboard plies adhesively laminated together. By "substantially entirely" is meant that at least 80% of the radial thickness of the die board is made up of paperboard plies.
- [0007]** In one embodiment, the part-cylindrical wall is formed entirely of a plurality of paperboard plies adhesively laminated together.
- 30 **[0008]** Suitably, in one embodiment the inner part-cylindrical surface has a diameter of approximately 482 to 489 mm. The wall can have a thickness of approximately 12.6 to 13.3 mm.
- [0009]** The wall can be constructed from plies of various types. In one embodiment, the plurality of paperboard plies include paperboard plies of at least two different types. By "different type" is meant that one or more of the caliper, grade, material composition, and strength properties of the plies are different.
- 35 **[0010]** In some embodiments, dimensional stability of the die board is improved by including one or more moisture-barrier plies. A moisture-barrier ply useful in the manufacture of the die board can be a laminate of at least one paper layer (e.g., kraft) and at least one substantially moisture-impervious layer such as polymer film or metal foil. Laminates such as paper/polymer/paper and paper/polymer/foil/polymer/paper are useful, these being merely exemplary and not limiting.
- 40 **[0011]** In one embodiment, the outermost ply is substantially thinner than at least some of the intermediate plies.
- [0012]** In one embodiment, the plurality of plies are helically wound one upon another and include an outermost ply forming the part-cylindrical outer surface. A gap between adjacent edges of the outermost ply does not exceed about 1 mm, and more preferably does not exceed about 0.8 mm.
- 45 **[0013]** In one embodiment, the die board is formed with about 15 to 25 paperboard plies ranging in thickness from about 0.25 mm (0.01 inch) to about 0.75 mm (0.03 inch), and has a wall thickness of about 10 to 15 mm (0.4 to 0.6 inch). This die board can also include one or more moisture-barrier plies.
- [0014]** The present disclosure also relates to methods for making rotary die boards. In one embodiment, a method for making die boards for a rotary die comprise the steps of: wrapping a plurality of plies, including a plurality of paperboard plies, one atop another about a cylindrical mandrel and adhering the plies to one another to form a hollow tube on the mandrel; removing the tube from the mandrel; cutting the tube lengthwise to form at least two part-cylindrical portions each formed by a part-cylindrical wall having a part-cylindrical inner surface and a part-cylindrical outer surface; and forming a pattern of slots in the part-cylindrical outer surface of each of the part-cylindrical portions, the slots being configured to hold die tools.
- 50 **[0015]** The plies can be wrapped in various ways, including helically, convolutedly, or linearly (i.e., by the linear draw process).
- [0016]** In one embodiment, the wrapping step includes wrapping a plurality of paperboard plies having an equilibrium moisture content not greater than about 4%. Such "extra-dry" paperboard (a "normal" paperboard ply typically having a

moisture content of about 6% or more during the wrapping step) has been found to be one factor that can contribute toward improved dimensional stability of the die board. In general, reducing the total amount of moisture in the tube as formed (whether by use of extra-dry paperboard, or by other means) tends to improve dimensional stability under changing ambient conditions.

5 [0017] In one embodiment, the wrapping step further comprises wrapping at least one moisture-barrier ply in the form of a laminate having at least one paper layer and at least one substantially moisture-impervious layer such as polymer film or metal foil.

[0018] BRIEF DESCRIPTION OF THE SEVERAL VIEWS OF THE DRAWING(S) Having thus described the present disclosure in general terms, reference will now be made to the accompanying drawings, which are not necessarily drawn to scale, and wherein:

10 FIG. 1 is a perspective view of a rotary die in accordance with one embodiment, being mounted to a roller of a die-cutting system;

15 FIG. 2 is a diagrammatic view depicting a first step of forming a die board in accordance with one embodiment;

FIG. 3 illustrates a second step of forming a die board in accordance with one embodiment; and

20 FIG. 4 illustrates a third step of forming a die board in accordance with one embodiment.

DETAILED DESCRIPTION OF THE DRAWINGS

25 [0019] The present inventions now will be described more fully hereinafter with reference to the accompanying drawings, in which some but not all embodiments of the inventions are shown. Indeed, these inventions may be embodied in many different forms and should not be construed as limited to the embodiments set forth herein; rather, these embodiments are provided so that this disclosure will satisfy applicable legal requirements. Like numbers refer to like elements throughout.

30 [0020] A rotary die **RD** in accordance with one embodiment of the invention is shown in FIG. 1. The rotary die comprises a substrate or die board **DB** formed as an arcuate (e.g., a hollow semi-cylindrical) structure, such as half of a hollow cylinder. The outer surface of the die board has a plurality of slots **S** formed therein, in a predetermined pattern, for holding a number of die tools **T**. Various types of die tools can be included, depending on the process the rotary die is designed to perform. Examples of die tools include steel rules or knives for die-cutting sheet material, serrated knives for perforating the sheet material, embossing tools for embossing the sheet material, creasing tools for creasing the sheet material, ejection rubbers for pushing out cut-out portions of the sheet material when forming windows or openings therein, and the like. The same rotary die can include two or more different types of tools, or can include only one type, depending on the requirements in each case.

35 [0021] As shown, in use, the rotary die **RD** is mounted on a roller **R** using bolts **B**. The roller having the rotary die thereon is arranged with another roller (generally referred to as the "anvil") to form a nip through which the sheet material being processed is passed.

40 [0022] The slots **S** can be formed by mechanical machining, but advantageously the slots are formed by burning with a laser. Laser-formed slots have the advantage of being controllable in width much more precisely than mechanically formed slots. Because the die tools are held in the die board by frictional engagement between the tools and the walls of the slots, it is advantageous to control the slot width as accurately as possible to ensure adequate frictional engagement with the tools.

45 [0023] The die board **DB** is a laminated paperboard structure rather than the conventional plywood type of construction built up from resin-coated hardwood veneers. More particularly, the die board **DB** can be formed predominantly, substantially entirely, or entirely of paperboard plies layered one upon another and adhered together via an adhesive disposed between facing surfaces of adjacent plies. The die board is formed by initially forming a cylindrical paperboard tube, and then cutting the tube lengthwise to form two or more arcuate part-cylindrical portions each of which is used for making one die board. As one example, in one embodiment described below, the tube can be cut in half lengthwise to form two semi-cylindrical portions each for forming one die board. Alternatively, however, a die board need not be semi-cylindrical, but can subtend an arc of less than 180° if desired.

50 [0024] FIG. 2 schematically illustrates a spiral tube-forming process and apparatus for making the cylindrical paperboard tube in accordance with one embodiment of the invention. As shown, a continuous, spirally wound tube **10** is formed on a stationary cylindrical mandrel **12**. A first ply **20** having a width **W** is fed onto the mandrel **12** at a winding angle α that is determined from the winding diameter of the ply, **D**, and the ply width, **W** of an ideal, perfectly uniform width and perfectly straight ply **20** by the formula:

$$\sin \alpha = W/\pi D$$

5 When the ply is wound at this winding angle, the ply will ideally form a perfect butt joint, wherein the adjacent edges of successive helical turns of the ply about the mandrel will butt against each other with no gap therebetween. In reality, of course, it is generally not possible to control all of the variables in the above formula perfectly, so in practice it is nearly impossible to attain zero ply gaps 100% of the time.

10 **[0025]** It is also to be noted that the ideal ply width **W** and winding angle α change by a small amount from ply to ply because the winding diameter **D** of each ply becomes successively greater as the wall thickness of the tube **10** is built up by each successive ply. However, the pitch of each ply must be the same since each ply layer must move the same axial distance along the mandrel for each revolution of the tube **10** on the mandrel. Accordingly, the ply width **W** and the winding angle α for all of the ply layers are calculated to maintain pitch as constant as practically possible (recognizing that paperboard plies are not obtainable in an infinite number of different widths, but only in certain width increments).

15 **[0026]** The ply **20** preferably is formed of paperboard. The ply **20** is referred to herein as the innermost ply because it forms the innermost surface of the tube that is constructed on the mandrel **12**. A plurality of intermediate plies, **22, 24, 26, 28, 30,** and **32** preferably formed of paperboard are coated with an adhesive at a conventional adhesive coating station **40** and are superimposed in radially layered relationship onto the innermost ply **20**. No adhesive is applied to the exterior face of the paperboard ply **32**. It is preferred to apply adhesive to both the interior and exterior face of the paperboard ply **22** that contacts the innermost paperboard ply **20**. In some embodiments, the adhesive can comprise an aqueous adhesive, and any of various aqueous adhesives can be used. In other embodiments, the adhesive can comprise a low-moisture or high- solids-content adhesive referred to herein as a "dry bond" adhesive. Various dry bond adhesives can be used, including but not limited to hot melt, silicate, dextrin, white glues such as PVA (polyvinyl acetate), EVA (ethylene vinyl acetate), and PVOH (polyvinyl alcohol), or a polymer resin adhesive (e.g., ionomer resin such as SURLYN®, or the like).

25 **[0027]** The radially layered plies are spirally wound onto and advanced axially along the mandrel by the action of a continuous winding belt **44** that is driven at a predetermined winding angle α by winding drums **46** and **48** as is well known in the art. At a location downstream of the winding belt **44**, a paperboard ply **50** is coated on both faces with adhesive via an adhesive station **52** and is thereafter spirally wound onto the partially formed tube **10** exiting the drive belt **44**. A final, outermost paperboard ply **54** is applied to the adhesive coated surface of paperboard ply **50** to thereby form the outermost surface of the tube **10**. The leading and trailing edges **64** and **66**, respectively, of the outermost ply **54** are laid adjacent, and preferably in edge-abutting relation to each other, to form a spiral seam **68** that can be visible or nearly invisible upon the surface of the final tube **10**, depending on the gap at seam **68**, which gap preferably is precisely controlled to be as small as possible while avoiding any overlap of the edges of the outermost ply **54**.

30 **[0028]** In other embodiments, the tube can include one or more non-paperboard plies. For example, one or more moisture-barrier plies can be included, such as metal foil (hereinafter referred to as "foil"), polymer film, parchment, or a paper/non-paper laminate. An example of a paper/non-paper laminate useful as a barrier layer is a laminate of two paper layers laminated together by a layer of a latex rubber-based adhesive. Alternatively, moisture-barrier plies can comprise laminates such as paper/polymer/paper, paper/polymer/foil/polymer/paper, etc. Such a moisture-barrier ply can be the outermost ply of the tube, or the innermost ply of the tube, or both the outermost and innermost plies can comprise moisture-barrier plies. It is also possible to include a moisture-barrier ply as an intermediate ply. The tube additionally or alternatively can include one or more non-paperboard, strength-enhancing plies, such as Formica or the like.

35 **[0029]** The continuous tube **10** is moved by the winding belt axially along and past the end of the mandrel where it is cut by one or more cutting stations **70**, typically in the form of radial saws or in the form of any of various tube cutting apparatus that will be known to those skilled in the art. The cutting station **70** can cut the continuous tube into discrete lengths equal to the desired lengths of the rotary die boards to be produced; alternatively, the cutting station can cut the tube into lengths longer than that of the die boards to be produced, and subsequent further cutting of the longer lengths can be performed to produce the desired lengths.

40 **[0030]** The next step of the process for producing die boards is illustrated in FIG. 3. A tube **100**, formed as described above and cut to the desired length, is cut in half lengthwise along a plane that passes through the central axis of the tube so as to divide the tube into two semi-cylindrical portions **102**. Each semi-cylindrical portion **102** will form one die board. As previously noted, it is not essential to the invention that the die board be generally semi-cylindrical (subtending an arc of about 180°), and hence alternatively the cutting step can comprise cutting the tube lengthwise in such a way as to produce two (or more) part-cylindrical portions each subtending an angle of less than 180°. The term "part-cylindrical" is used herein to refer to any structure that can be formed by cutting a hollow cylindrical tube lengthwise along two circumferentially spaced planes that are axially extending (or generally axially extending); the angle subtended by the two planes can be constant along the axial direction, although such is not an absolute requirement.

[0031] Each part-cylindrical die board 102 is then processed to form the pattern of slots for holding die tools, as illustrated in FIG. 4. More particularly, slots 104 are formed in the outer surface 106 of the die board. The slots can extend entirely through the thickness of the die board wall to the inner surface 108 of the die board. As noted, the slots can be formed in various ways. While mechanical techniques for forming the slots can be used, in preferred embodiments of the invention the slots are formed by burning the paperboard material with a laser such as a CO₂ laser. Laser formation offers the advantage of substantially greater accuracy and less variability in the slot dimensions, particularly the slot diameter or width, which is an important parameter in terms of the ability of the slot to frictionally grip the die tools inserted into the slots. The pattern of slots formed in the die board depends upon the configuration of die tools to be inserted, and thus can vary in each case. It is advantageous to form a series of spaced slots or holes 104 for a given die tool such that there is paperboard material between adjacent holes 104, which the die tool must break through when inserted into the series of holes. In this manner, the die tool is frictionally gripped more tenaciously and firmly.

[0032] The final step in the fabrication of a rotary die is to insert the various die tools into the slots 104.

[0033] As an example for illustrative purposes, a rotary die board in accordance with one embodiment can be constructed from a tube constructed from a plurality of paperboard plies as follows:

# Plies	Caliper (inch / mm)	Grade	Width (inch / mm)	Max. Ply Gap (inch / mm)
1 (outside)	0.013 / 0.33	Outer Ply	7.25/184.2	0.03/0.8
1	0.025 / 0.64	Grade A	7.22/183.4	0.06/1.5
19	0.025 / 0.64	Grade B	7.19/182.6	0.092/2.3
1 (inside)	0.025 / 0.64	Grade A	7.22/183.4	0.06/1.5
Sum of Plies	0.538 / 13.67			

[0034] The die board has an inside diameter ("ID") of 19.0 to 19.25 inches (482.6 to 489.0 mm), a thickness of 0.495 to 0.525 inch (12.6 to 13.3 mm), and a wrap length ("W", the length circumferentially along the outer surface from one edge to the opposite edge) of 31.69 to 31.75 inches (804.9 to 806.5 mm). The maximum twist of the die board should be 0.25 inch (6.4 mm). Twist is measured by placing three corners of the die board against a very flat surface and measuring how high the fourth corner is above the surface. Ideally, all four corners should touch the surface.

[0035] As noted above, the paperboard tube used in forming the die board can be constructed from plies of two or more types. For example, in the above example, the tube is constructed from three different ply types: one ply of "outer ply" type, two plies of "Grade A" type, and 19 plies of "Grade B" type. The "outer ply" type is selected for its particular suitability for use as the outermost ply that will form the outer surface of the die board. Accordingly, the outermost ply generally should have a smooth surface, which may be smoother than that of the "Grade A" and/or "Grade B" plies. The outermost ply in the above example also is substantially thinner than the other plies of the tube, although such is not a necessity. A suitable outermost ply can be, as a non-limiting example, a parchment ply or the like. The intermediate plies between the outermost and innermost plies can be a different grade (e.g., a lower or less-costly grade) of paperboard than either or both of the outermost and innermost plies, as in the above example wherein the intermediate plies are "Grade B" paperboard.

[0036] Alternatively, it is also possible to construct the tube from plies of only one type.

[0037] In accordance with yet another aspect of the invention, in some cases it may be desirable to include an impregnated ply as the outermost ply 54 and/or the innermost ply 20 of the die board (FIG. 2). The impregnated ply can comprise, for example, a paperboard ply impregnated with a resin or polymer composition such as phenolic resin or polyester. The impregnated ply can serve as a moisture barrier and/or can impart a desired surface finish to the die board, and/or can be a strength-enhancing feature. The impregnated ply alternatively can be located other than at the outermost or innermost position, i.e., as an intermediate ply of the die board. Various embodiments are possible. In one embodiment, the die board includes only one impregnated ply comprising either the outermost ply, an intermediate ply, or the innermost ply. In another embodiment, the die board includes a plurality of impregnated plies, which can be contiguous or can have one or more non-impregnated plies (i.e., free of any resin or polymer impregnant) disposed therebetween.

[0038] It is advantageous, however, to minimize the use of such impregnated plies, and most advantageously to omit impregnated plies altogether. In the case of using a laser for cutting the slots in the die board, a phenolic-impregnated ply is undesirable because the phenolic tends to burn.

[0039] It is also possible to include in the die board one or more paperboard plies that are sized or otherwise treated to be water-resistant, although without impregnating the plies with a resin or polymer impregnant. For example, a paperboard ply can be sized with a sizing composition such as rosin and alum, alkyl ketene dimer (AKD), or alkenyl succinic anhydride (ASA), to render the paperboard substantially resistant to absorbing liquids such as water.

[0040] Additional examples and results of tests conducted on predominantly paperboard rotary die boards are set forth below.

Examples and Test Results

5
[0041] Rotary die boards (RDBs) need to be dimensionally stable in order to produce die cut parts that are within tolerance no matter what the ambient conditions, which means that the dimensions should remain fairly constant when changes in ambient relative humidity occur. Composite Can and Tube Institute (CCTI) Technical Committee Report TCR-2 teaches a rule of thumb that spirally wound paper tubes can change 0.12% in length, 0.09% in outside diameter, 10
 0.6% in wall thickness, and 0.03% in inside diameter for each percentage unit change in tube moisture content, on an air dry basis (ADB). For example, a 100-inch long tube initially exposed to a 20% Relative Humidity (RH) environment and then moved into a 90% RH environment (a 12% change in equilibrium moisture content) can theoretically grow in length by 1.44 inches, to a length of 101.44 inches. Therefore, paper moisture content and ambient air RH are important factors affecting rotary die board dimensions. Temperature, adhesive type, and sizing tend to have little effect unless 15
 they shield the paper from moisture transport, while paper density can have some effect. Tubes made of very dense papers will change in dimensions a little more (10-20%) than those of average density. The purpose of the work done as shown in the following examples was to produce a more dimensionally stable paper split tube or rotary die board (RDB) by impeding moisture transport between the ambient air and the paper by using moisture barriers and controlling the moisture introduced into the tube during spiral winding. The ultimate goal was to produce a paper RDB that is as 20
 dimensionally stable as the current plywood industry standard.

EXAMPLE 1:

25
[0042] Paper tubes having dimensions of 72" long x ½" wall thickness were made using the spiral winding process with a 19.25" diameter mandrel. The tube wall thickness and build-up consisted of approximately 20 plies of 0.013", 0.025" and 0.030" high-strength papers made from recycled cardboard, with the tube outer diameter controlled at 20.250". The outermost ply consisted of a 0.00256" thick (35 lb/3000 ft²) green-colored parchment material manufactured by Ahlstrom Corporation. A dextrin-based adhesive (viscosity=600 cps) was used to adhere the body plies. The outermost 30
 ply was adhered using a PVA-based adhesive (viscosity =1600 cps).

35
[0043] Once manufactured, the tubes were allowed to dry and stabilize for 48 hours before splitting the tube in half lengthwise using a band saw. The split tubes or rotary die boards (RDB), along with standard birch plywood RDB (the control), were then placed in an environmental chamber controlled at 100° F and 20% RH for 4 days. The RDBs were then removed and immediately weighed and measured for length ("L"), inside diameter or span ("ID"), and wrap length ("W") on the top, middle, and bottom of each tube. The RDBs were then placed in another environmental chamber set 40
 at 100° F and 95% RH for 2 days and were again measured as noted above. The percentage changes in length, ID, wrap, and weight were calculated. Table 1 shows the results.

40

TABLE 1		
Dimension	Paper RDB-Example 1, % Change	Plywood RDB, % Change
W	0.07	0.07
ID	4.92	2.53
L	1.13	0.10
Weight	6.26	5.54

45

50
[0044] Table 1 shows that the RDB length and the ID changed by greater percentages for the paper tube in comparison with the current standard plywood design, which indicates that plywood is more dimensionally stable than the paper RDB. The change in wrap was essentially the same for both boards. It is to be noted that the angle of wind of the paper tube was in the range of 80 to 90 degrees, and hence the CD direction of the paperboard plies was nearly in alignment with the length of the RDB. Thus, the test results in Table 1 are believed to reflect the fact that the paperboard making up the paper RDB has greater dimensional stability in the paper machine direction (MD) of the board than in the cross machine direction (CD).

55
[0045] In order to improve the length and ID dimensional stability of the paper RDBs, options were considered involving different types of moisture barriers strategically placed within the tube build-up during the winding process. EXAMPLE 2 shows some of the options considered.

EP 1 925 409 B1

EXAMPLE 2:

[0046] Paper tubes having dimensions of 72" long x ½" wall thickness were made using the spiral winding process with a 19.25" diameter mandrel. The tube wall thickness and build-up consisted of approximately 20 plies of 0.013", 0.025" and 0.030" high-strength papers (unless otherwise noted) made from recycled cardboard, with the tube outer diameter controlled at 20.250". Test RDB numbers 9 and 10 used medium-strength "square" papers (i.e., papers with fibers aligned in both CD and MD directions giving nearly equal paper strength in both directions). The outermost ply for all test RDBs except for RDB numbers 2 through 4 consisted of a 0.00256" thick (35 lb/3000 ft²) green-colored parchment material manufactured by Ahlstrom Corporation. RDB numbers 2-4 did not use the parchment material. A dextrin-based adhesive (viscosity=600 cps) was used to adhere the body plies except where otherwise noted in the tables below. The outermost ply was adhered using a PVA-based adhesive (viscosity =1400 cps) unless otherwise noted in the tables. Many of the RDBs listed in the tables were treated with various materials as noted: SBR adhesive coating, polyurethane (water based) coating, and wax saturation. RDBs 7 and 8 used moisture barrier laminates having the structure kraft/poly/foil/poly/kraft manufactured by Jen-Coat, and another moisture barrier laminate having the structure kraft/poly/kraft (specifically, Sellowrap 40 from Converdis) located at the 2nd ply from the inside and the 3rd ply from the outside.

[0047] Once manufactured, the tubes were allowed to dry and stabilize for 48 hours before splitting the tubes in half lengthwise using a band saw. The RDBs were then measured for length, ID, and wrap on the top, middle, and bottom of the tube, and were weighed. Half of the samples of each RDB build-up were placed in an environmental chamber controlled at 100° F and 20% RH (referred to as a "desert" environment) for 4 days, and the other half were placed in another environmental chamber set at 100° F and 95% RH (referred to as a "jungle" environment) for 2 days. After conditioning, the RDBs were measured again as noted above. The averages of the absolute values of the differences in length, ID, wrap, and weight between normal ambient conditions and the desert and jungle environments were calculated. Table 2A and 2B shows the results.

TABLE 2A: AMBIENT TO DESERT

RDB #	RDB BUILD-UP	AVERAGE ABSOLUTE CHANGE			
		% MOISTURE CHANGE	Wrap Top, inch	Length, inch	I.D.-Span, inch
1	CONTROL, DEXTRIN ADHESIVE	-3.61	0.06	0.53	0.50
2	SBR ADHESIVE COATED	-0.39	0.00	0.38	0.28
3	POLYURETHANE COATED	-3.01	0.00	0.50	0.53
4	WAX SATURATED	4.61	0.09	0.13	0.09
5	SBR ADHESIVE OUTSIDE/INSIDE PLIES ONLY	-4.23	0.03	0.63	0.59
6	SBR ADHESIVE ALL PLIES	-3.77	0.06	0.59	0.59
7	FOIL MOISTURE BARRIER	-1.40	0.03	0.44	0.16
8	SELLOWRAP MOISTURE BARRIER	-2.74	0.03	0.53	0.38
9	SQUARE PAPER	-3.97	0.16	0.38	0.59
10	SQUARE PAPER, SBR ADHESIVE OUTSIDE/INSIDE	-3.99	0.09	0.47	0.63

TABLE 2B: AMBIENT TO JUNGLE					
RDB #	RDB BUILD-UP	AVERAGE CHANGE			
		% MOISTURE CHANGE	Wrap, inch	Length, inch	ID, inch
1	CONTROL, DEXTRIN ADHESIVE	8.70	0.06	1.11	1.25
2	SBR ADHESIVE COATED	3.79	0.09	0.63	0.81
3	POLYURETHANE COATED	7.57	0.03	1.44	1.03
4	WAX SATURATED	3.40	0.06	0.44	0.53
5	SBR ADHESIVE OUTSIDE/ INSIDE PLYS ONLY	4.78	0.03	0.66	0.63
6	SBR ADHESIVE ALL PLYS	4.93	0.06	0.63	0.78
7	FOIL MOISTURE BARRIER	1.25	0.06	0.19	0.41
8	SELLOWRAP MOISTURE BARRIER	2.25	0.06	0.34	0.59
9	SQUARE PAPER	7.83	0.09	0.72	1.28
10	SQUARE PAPER, SBR ADHESIVE OUTSIDE/INSIDE	5.36	0.00	0.53	1.03

[0048] The RDBs that appeared to be best in terms of tube length and ID dimensional stability, and the most practical to manufacture, were RDB #7 (foil moisture barrier) and #8 (Sellowrap moisture barrier). Saturating these large tubes in hot wax or coating using other materials are deemed not cost-effective. The next step was to investigate the effect of multiple layers of moisture barriers, including extra-dry papers.

EXAMPLE 3:

[0049] 72" long x 1/2" thick wall paper tubes were made using the spiral winding process with a 19.25" diameter mandrel. The tube wall thickness and build-up consisted of 18 to 20 plies of 0.013", 0.025" and 0.030" high-strength papers made from recycled cardboard with the outer diameter controlled at 20.250". The outermost ply consisted of a 0.00256" thick (35 lb/3000 ft²) green-colored parchment material manufactured by Ahlstrom Corporation. A dextrin-based adhesive (viscosity=600 cps) was used to adhere the body plies. The outermost ply was adhered using a PVA-based adhesive (viscosity =1400 cps). Sellowrap 40 made by Converdis, a moisture barrier paper, was placed in various configurations within the tube build-up (see Table 3). Also, RDBs 20 through 24 were made using regular high-strength papers (moisture content approximately 6%) and RDBs 25 through 28 were made using extra-dry high-strength paper (moisture content approximately 4%).

[0050] Once manufactured, the tubes were allowed to dry and stabilize for 48 hours before splitting the tubes in half lengthwise using a band saw, and then the tube were immediately measured for length, ID, and wrap on the top, middle, and bottom of the tube, and were weighed. The resulting paper RDBs, along with standard birch plywood RDB (the control), were then placed in an environmental chamber controlled at 100° F and 20% RH for 5 days and measured again. The averages of the absolute changes in the length, ID, wrap, and weight were calculated. Table 3 shows the results ("MB" = moisture barrier).

TABLE 3: AMBIENT TO DESERT						
RDB #	RDB BUILD-UP	AVERAGE ABSOLUTE DIFFERENCES				
		% Moisture Change	WRAP inch	LENGTH inch	ID inch	TOTAL inch
20	CONTROL - NO MB	-3.35	0.08	0.24	0.35	0.68
21	SELLOWRAP - 2 (IN/OUT)	-2.07	0.10	0.32	0.15	0.57

EP 1 925 409 B1

(continued)

RDB #	RDB BUILD-UP	AVERAGE ABSOLUTE DIFFERENCES				
		% Moisture Change	WRAP inch	LENGTH inch	ID inch	TOTAL inch
22	SELLOWRAP - 3 (IN/MID/OUT)	-2.07	0.07	0.33	0.15	0.55
23	SELLOWRAP-4 (2IN/2OUT)	-1.70	0.08	0.30	0.15	0.53
24	SELLOWRAP - 4 (1IN/1MID/1MID/ 1OUT)	-1.98	0.06	0.31	0.23	0.60
25	EXTRA-DRY HIGH- STRENGTH PAPER (4% MOISTURE) - NO MB	-2.72	0.06	0.44	0.44	0.94
26	EXTRA-DRY HIGH- STRENGTH PAPER (4% MOISTURE), SELLOWRAP - 2 (IN/OUT)	-1.69	0.04	0.25	0.08	0.38
27	EXTRA-DRY HIGH- STRENGTH PAPER (4% MOISTURE), SELLOWRAP - 4 (2IN/2OUT)	-1.43	0.06	0.25	0.13	0.44
28	EXTRA-DRY HIGH- STRENGTH PAPER (4% MOISTURE), FOIL - 2 (IN/OUT)	-3.37	0.02	0.23	0.02	0.27
PLY	PLYWOOD	-0.91	0.04	0.25	0.46	0.75

[0051] Table 3 shows that RDBs made with the extra-dry high-strength papers generally had better dimensional stability, especially in length and ID, compared to those made using the regular papers. The RDBs made using the Sellowrap and foil moisture barriers had better dimensional stability than those without, and had smaller ID changes than the Plywood control. However, distributing multiple plies of moisture barrier papers throughout the RDB wall does not seem to improve the dimensional stability as compared to placing one or two moisture-barrier plies on the inside and outside.

EXAMPLE 4:

[0052] 82" long x 1/2" thick wall paper tubes were made using the spiral winding process with a 19.125" diameter mandrel. The tube wall thickness and build-up consisted of 18 to 20 plies of 0.015", 0.025" and 0.030" extra-dry (moisture content approximately 4%) high-strength papers made from recycled cardboard, with the outer diameter controlled at 20.145". The outermost ply consisted of a 0.00256" thick (35 lb/3000 ft²) green-colored parchment material manufactured by Ahlstrom Corporation. A dextrin-based adhesive (viscosity=600 cps) was used to adhere the body plies on RDB numbers 23, 37, 38, 39, and 42. A silicate adhesive was used for the body plies in RDB numbers 40 and 41. The outermost ply was adhered using a PVA-based adhesive (viscosity =1400 cps). Sellowrap 40 made by Converdis, and a kraft/polypropylene/ kraft laminate (designated "PP") made by Jen-Coat were the moisture barrier papers compared in this experiment. The moisture barrier papers were located as the 2nd ply from the inside ply and as the 5th ply from

EP 1 925 409 B1

the outside within the tube build-up, and in other configurations as shown in Table 4A.

[0053] Once manufactured, the tubes were allowed to dry and stabilize for 48 hours (at room temperature, 55% RH) before splitting them in half lengthwise using a band saw, and then the tubes were immediately measured for length ID, and wrap on the top, middle, and bottom of the tube, and were weighed. The resulting RDBs, along with standard birch plywood RDB (the control), were then placed in an environmental chamber controlled at 100° F and 20% RH for 7 days and measured again. Tube samples were also weighed and oven dried in order to calculate the % moisture. The average of the absolute change for the length, ID, wrap, and weight were calculated. Tables 4A and 4B shows the results.

TABLE 4A: 20% RH ROOM MOISTURE STUDY (7 DAYS)				
RDB #, DESCRIPTION	AVG INITIAL DAY 1 MOISTURE %	AVERAGE ABSOLUTE DIFFERENCES		
		% Moisture Change	Length Change, in.	ID Change, in.
23, DEXTRIN, SELLOWRAP 2 LAYERS IS/OS	8.5	-1.94	0.31	0.15
37, DEXTRIN, NO MB	9.5	-3.99	0.67	0.48
38, DEXTRIN, PP MB INSIDE ONLY	8.6	-2.77	0.52	0.27
39, DEXTRIN, PP MB OUTSIDE ONLY	9	-3.33	0.58	0.33
40, SILICATE, NO MB	10.3	-4.88	0.73	0.71
41, SILICATE, PP MB IS/OS	11	-2.59	0.54	0.25
42, DEXTRIN, PP MB IS/OS	8.5	-1.88	0.38	0.17

TABLE 4B: ID VALUES AT 55% RH VERSUS 20% RH		
DESCRIPTION	ID @ Splitting, inch	ID @ 7 Days, inch
23, DEXTRIN, SELLOWRAP 2 LAYERS IS/OS	19.31	19.25
37, DEXTRIN, NO MB	19.21	18.73
38, DEXTRIN, PP MB INSIDE ONLY	19.19	18.92
39, DEXTRIN, PP MB OUTSIDE ONLY	19.25	18.92
40, SILICATE, NO MB	19.13	18.42
41, SILICATE, PP MB IS/OS	19.25	19.46
42, DEXTRIN, PP MB IS/OS	19.25	19.42

[0054] From the results summarized in Table 4A, it was noted that RDB numbers 23 and 42 had the best dimensional stability in terms of length and ID changes, as had been previously observed when moisture barriers were located on both the inside and outside of the tube. It is thought such moisture barriers add resistance and hinder moisture transport between the ambient air and the tubes. Also, the silicate adhesive apparently imparts too much moisture to the paper, causing the paper to shrink with age if the ambient conditions become drier. The results in Table 4B show that the moisture barrier on both the inside and outside maintains the ID on the high side. The PP moisture barrier causes the ID to actually decrease with age, and the Sellowrap causes the ID to decrease slightly with age. It is preferred to keep the ID for this particular RDB size within the range 18-7/8" to 19-5/16".

EXAMPLE 5:

[0055] 72" long x 1/2" thick wall paper tubes were made using the spiral winding process with a 19.25" diameter mandrel.

EP 1 925 409 B1

The tube wall thickness and build-up consisted of approximately 20 plies of 0.013", 0.025" and 0.030" high-strength papers made from recycled cardboard, with the outer diameter controlled at 20.250". The outermost ply consisted of a 0.00256" thick (35 lb/3000 ft²) green-colored parchment material manufactured by Ahlstrom Corporation. A dextrin-based adhesive (viscosity=600 cps) was used to adhere the body plies. The outermost plies were adhered using a PVA-based adhesive (viscosity =1400 cps). RDB number 15 (CONTROL) included no moisture barriers. RDB numbers 17 and 18 used moisture barrier laminates having the structure kraft/poly/foil/poly/kraft (FOIL) manufactured by Jen-Coat, and another moisture barrier laminate having the structure kraft/poly/kraft (Sellowrap 40 by Converdis), 1 ply each, located on the 2nd ply from the inside and the 3rd ply from the outside of the tube.

[0056] Once manufactured, the tubes were allowed to dry and stabilize for 48 hours before splitting in half lengthwise using a band saw. The resulting RDBs, along with standard birch plywood RDB (the control), were then sent to a die maker where they were laser cut and ruled using a normal rotary die design. The RDBs were then measured for weight, bolt hole spacing ("H"), length, ID, and wrap. The RDBs were then placed in an environmental chamber set at 100° F and 95% RH for 2 days and were again measured the same as above. The average of the absolute difference in the hole spacing, length, ID, wrap, and weight were calculated. Table 5A shows the results.

[0057] The same die boards from Table 5A were placed in another environmental chamber set at 100° F and 20% RH for 3 days and measured the same as above. The average of the absolute difference in the hole spacing, length, ID, wrap, and weight were calculated for the 90% RH and 20% RH conditions. Table 5B shows the results. Bowing in the center of the RDBs was measured on both right and left sides of the board and the condition of each of the RDBs was noted.

TABLE 5A: RULED DIE, AMBIENT TO JUNGLE					
RDB #	RDB BUILD-UP	AVG DIFFERENCES			
		% MOIST.	H, inch	Length (L), inch	Wrap (W), inch
N/A	PLYWOOD	1.91	0.01	0.05	0.16
15	CONTROL	1.31	0.09	0.16	0.09
17	FOIL	0.25	0.00	0.05	0.03
18	SELLOWRAP	0.34	0.00	0.06	0.09

TABLE 5B: RULED DIE, JUNGLE TO DESERT									
RDB #	RDB BUILD-UP	AVERAGE ABSOLUTE DIFFERENCES					BOWING IN CENTER		CONDITION OF RDB
		% Moist.	H, inch	Length (L), inch	Wrap (W), inch	ID, inch	Left inch	Right, inch	
N/A	PLYWOOD	-3.71	0.04	0.08	0.13	0.27	1/16	3/16	OK
15	CONTROL	-3.15	0.23	0.31	0.13	0.71	1/4	1/4	RULES LOOSE
17	FOIL	-2.01	0.13	0.19	0.03	0.52	3/16	1/4	RULES LOOSE
18	SELLOWRAP	-2.31	0.12	0.13	0.13	0.69	1/4	1/4	RULES LOOSE

[0058] Table 5A shows that the RDBs using the foil or Sellowrap moisture barriers improved the dimensional stability, to a point approaching that of the plywood, by adding resistance and thereby preventing moisture transport into the paper. Table 5B shows that the foil and Sellowrap moisture barriers improved the length dimensional stability over the control with no moisture barrier. It was found that the steel rules in the board would become loose when the RDBs were dried. This problem was later resolved by laser cutting smaller slots in the RDB. Steel rules for the 66" rotary die board were 0.0575" wide. For optimum rule fit and performance, "smooth" wall laser cut slots should measure using a taper gage 0.030" to 0.048" wide from the underneath side and 0.040" to 0.048" from the top side of the board. "Pulse" laser jagged wall cut slots should measure using a taper gage 0.030" to 0.040" wide from both underneath and top sides of

the board.

EXAMPLE 6

5 **[0059]** 72" long x 1/2" thick wall paper tubes were made using the spiral winding process with a 19.25" diameter mandrel. The tube wall thickness and build-up consisted of 18 to 20 plies of 0.013", 0.025" and 0.030" high-strength papers made from recycled cardboard, with the outer diameter controlled at 20.250". The outermost ply consisted of a 0.00256" thick (35 1b/3000 ft²) green-colored parchment material manufactured by Ahlstrom Corporation. A dextrin-based adhesive (viscosity=600 cps) was used to adhere the body plies. The outermost plies were adhered using a PVA-based adhesive (viscosity =1400 cps). Sellowrap 40 made by Converdis, a moisture barrier laminate, was placed in various configurations within the tube build-up (see Table 6). RDB number 24 was made using regular high-strength papers (moisture content approximately 6%) and RDB numbers 25 and 27 were made using extra-dry high-strength paper (moisture content approximately 4%).

10
15 **[0060]** Once manufactured, the tubes were allowed to dry and stabilize for 48 hours before splitting the tubes in half lengthwise using a band saw. The resulting RDBs, along with standard birch plywood RDB (the control), were then sent to a die maker where they were laser cut and ruled using a normal rotary die design. The RDBs were then measured for weight, bolt hole spacing ("H"), length, wrap, and ID. The RDBs were then placed in an environmental chamber set at 100° F and 95% RH for 3 days and again measured the same as above. The average of the absolute difference in the hole spacing, length, ID, wrap, and weight were calculated. Table 6 shows the results.

20

TABLE 6: RULED DIE, AMBIENT TO DESERT

RDB #	RDB BUILD-UP	AVERAGE ABSOLUTE DIFFERENCES					Center Bow, Inch
		% MOIST. CHANGE	H, Inch	L, Inch	W, Inch	ID, Inch	
PLY 24	PLYWOOD	-1.81	0.02	0.07	0.03	0.48	0.13
	HIGH STRENGTH PAPER (6% MOISTURE), SELLOWRAP - 4 (1IN/1MID/1MID/1OUT)	-1.46	0.08	0.07	0.05	0.48	0.25
25	EXTRA-DRY HIGH-STRENGTH PAPER (4% MOISTURE) - NO MB	-1.44	0.08	0.10	0.03	0.46	0.22
27	EXTRA-DRY HIGH-STRENGTH PAPER (4% MOISTURE), SELLOWRAP - 4 (2IN/2OUT)	-1.11	0.07	0.07	0.00	0.33	0.19

25
30
35
40
45
50 **[0061]** Table 6 shows that the RDB number 27 using the Sellowrap moisture barriers and extra-dry papers improved the dimensional stability over that of the plywood, by adding resistance and thereby preventing moisture transport into the paper. RDB number 27 also prevented shrinkage of the rule slot, thereby preventing the rules from becoming loose in the board. Also, it was found that loosening of the rules can be prevented by laser cutting smaller slots in the RDB. Steel rules for the 66" rotary die board are 0.0575" wide. For optimum rule fit and performance, "smooth" wall laser cut slots should measure using a taper gage 0.030" to 0.048" wide from the underneath side and 0.040" to 0.048" from the top side of the board. "Pulse" laser jagged wall cut slots should measure using a taper gage 0.030" to 0.040" wide from both underneath and top sides of the board.

55

[0062] Many modifications and other embodiments of the inventions set forth herein will come to mind to one skilled in the art to which these inventions pertain having the benefit of the teachings presented in the foregoing descriptions and the associated drawings. Therefore, it is to be understood that the inventions are not to be limited to the specific embodiments disclosed and that modifications and other embodiments are intended to be included within the scope of the appended claims. Although specific terms are employed herein, they are used in a generic and descriptive sense only and not for purposes of limitation.

Claims

1. A die board (DB) for a rotary die, comprising:

an arcuate part-cylindrical wall having an outer part-cylindrical surface and an inner part-cylindrical surface;

characterized in that the part-cylindrical wall is formed at least predominantly of a plurality of paperboard plies (20, 22, 24, 26, 28, 30, 32, 50, 54) adhesively laminated together..

2. The die board of claim 1, further comprising a plurality of slots (S) formed in the outer part-cylindrical surface of the wall for receiving die tools.

3. The die board of claim 1 or 2, wherein the part-cylindrical wall is formed substantially entirely of a plurality of paperboard plies adhesively laminated together.

4. The die board of any preceding claim, wherein the inner part-cylindrical surface has a diameter of approximately 482 to 489 mm.

5. The die board of claim 4, wherein the part-cylindrical wall has a thickness of approximately 12.6 to 13.3 mm.

6. The die board of any preceding claim, wherein the plurality of paperboard plies (20, 22, 24, 26, 28, 30, 32, 50, 54) include paperboard plies of at least two different types.

7. The die board of any preceding claim, wherein an outermost ply of the die board is substantially thinner than at least some of the other plies.

8. The die board of any preceding claim, wherein the plies include at least a first moisture-barrier ply.

9. The die board of claim 8, wherein the first moisture-barrier ply comprises a laminate of at least one paper layer and at least one substantially moisture-impervious layer.

10. The die board of claim 8, wherein the first moisture-barrier ply is proximate a radially outer surface of the die board.

11. The die board of claim 10, further comprising a second moisture-barrier ply proximate the radially outer surface of the die board.

12. The die board of claim 9, wherein the first moisture-barrier ply is proximate a radially inner surface of the die board.

13. The die board of claim 12, further comprising a second moisture-barrier ply proximate a radially outer surface of the die board.

14. The die board of claim 13, further comprising a third moisture-barrier ply located radially inwardly of the first and second moisture-barrier plies.

15. The die board of claim 13, wherein there is a substantially greater number of paperboard plies than moisture-barrier plies.

16. The die board of claim 1, comprising approximately 15 to 25 paperboard plies (20, 22, 24, 26, 28, 30, 32, 50, 54) ranging in thickness from about 0,254 mm (0.01 inch) to about 0,762 mm

EP 1 925 409 B1

(0.03 inch), the die board having a wall thickness of about 10,2 to 15,2 mm (0.4 to 0.6 inch).

17. A method for making die boards for a rotary die, comprising the steps of:

5 wrapping a plurality plies, predominantly made up of a plurality of paperboard plies (20, 22, 24, 26, 28, 30, 32, 50, 54), one atop another about a cylindrical mandrel (12) and adhering the plies to one another to form a hollow predominantly paperboard tube on the mandrel;
removing the tube (10) from the mandrel; and
10 cutting the tube lengthwise to form at least two part-cylindrical portions (102) each formed by a part-cylindrical wall having a part-cylindrical inner surface and a part-cylindrical outer surface.

18. The method of claim 17, further comprising the step of:

15 forming a pattern of slots (S) in the part-cylindrical outer surface of each of the part-cylindrical portions (102), the slots being configured to hold die tools (T).

19. The method of claim 17 or 18, wherein the wrapping step comprises helically wrapping the plies about the cylindrical mandrel (12).

20 20. The method of claim 17 or 18 or 19, wherein the wrapping step comprises wrapping plies of at least two different types.

21. The method of any one of claims 17 to 20, wherein the wrapping step includes wrapping at least one moisture-barrier ply.

25 22. The method of claim 17, wherein the wrapping step includes wrapping at least one moisture-barrier ply in the form of a laminate having at least one paper layer and at least one substantially moisture-impervious layer.

23. The method of claim 22, wherein the wrapping step includes wrapping at least two of said moisture-barrier plies each in the form of said laminate.

30 24. The method of claim 17, wherein the wrapping step includes wrapping a plurality of paperboard plies having a moisture content not greater than about 4%.

35 25. The method of claim 24, wherein the wrapping step further comprises wrapping at least one moisture-barrier ply in the form of a laminate having at least one paper layer and at least one substantially moisture-impervious layer.

Patentansprüche

40 1. Matrizenplatte (DB) für eine rotierende Matrize mit:

einer gewölbten teilzylindrischen Wandung, die eine teilzylindrische Außenoberfläche und eine teilzylindrische Innenoberfläche aufweist,

dadurch gekennzeichnet, dass

45 die teilzylindrische Wandung aus mindestens vorwiegend einer Mehrzahl von Papplagen (20, 22, 24, 26, 28, 30, 32, 50, 54) gebildet ist, die laminiert miteinander verklebt sind.

50 2. Matrizenplatte nach Anspruch 1, bei welcher in der teilzylindrischen Außenoberfläche der Wandung eine Mehrzahl von Schnitzen S zur Aufnahme von Formwerkzeugen ausgebildet ist.

3. Matrizenplatte nach Anspruch 1 oder 2, bei welcher die teilzylindrische Wandung im Wesentlichen zur Gänze aus einer Mehrzahl von Papplagen gebildet ist, die laminiert miteinander verklebt sind.

55 4. Matrizenplatte nach einem der vorstehenden Ansprüche, bei welcher die teilzylindrische Innenoberfläche einen Durchmesser von näherungsweise 482 bis 489 mm hat.

5. Matrizenplatte nach Anspruch 4, bei welcher die teilzylindrische Wandung eine Dicke von näherungsweise 12, 6 bis 13,3 mm hat.

EP 1 925 409 B1

6. Matrizenplatte nach einem der vorstehenden Ansprüche, bei welcher die Mehrzahl von Papplagen (20, 22, 24, 26, 28, 30, 32, 50, 54) Papplagen mindestens zweier unterschiedlicher Arten enthalten
- 5 7. Matrizenplatte nach einem der vorstehenden Ansprüche, bei welchem die äußerste Lage der Matrizenplatte wesentlich dünner als mindestens einige der anderen Lagen ist.
8. Matrizenplatte nach einem der vorstehenden Ansprüche, bei welcher die Lagen mindestens eine erste Feuchtigkeitsbarrierenlage enthalten.
- 10 9. Matrizenplatte nach Anspruch 8, bei welcher die erste Feuchtigkeitsbarrierenlage ein Laminat von mindestens einer Papierschicht und mindestens einer im Wesentlichen feuchtigkeitsundurchlässigen Schicht aufweist.
10. Matrizenplatte nach Anspruch 8, bei welcher die erste Feuchtigkeitsbarrierenlage einer radial äußeren Oberfläche der Matrizenplatte benachbart ist.
- 15 11. Matrizenplatte nach Anspruch 10, bei welcher eine zweite Feuchtigkeitsbarrierenlage neben der radial äußeren Oberfläche der Matrizenplatte vorgesehen ist.
- 20 12. Matrizenplatte nach Anspruch 9, bei welcher die erste Feuchtigkeitsbarrierenlage neben einer radial inneren Oberfläche der Matrizenplatte angeordnet ist.
13. Matrizenplatte nach Anspruch 12, bei welcher eine zweite Feuchtigkeitsbarrierenlage neben einer radial äußeren Oberfläche der Matrizenplatte vorgesehen ist.
- 25 14. Matrizenplatte nach Anspruch 13, ferner mit einer dritten Feuchtigkeitsbarrierenlage, die radial innerhalb der ersten und zweiten Feuchtigkeitsbarrierenlagen angeordnet ist.
15. Matrizenplatte nach Anspruch 13, bei welcher die Anzahl von Papplagen erheblich größer als die Anzahl der Feuchtigkeitsbarrierenschichten ist.
- 30 16. Matrizenplatte nach Anspruch 1, mit etwa 15 bis 25 Papplagen (20, 22, 24, 26, 28, 30, 32, 50, 54), welche in ihrer Dicke von etwa 0,254 mm (0,01 Zoll) bis etwa 0,762 mm (0,03 Zoll) liegen, wobei die Matrizenplatte eine Wanddicke von etwa 10,2 bis 15, 2 mm (0,4 bis 0,6 Zoll) hat.
- 35 17. Verfahren zur Herstellung von Matrizenplatten für rotierende Matrizen mit den Schritten:
- Wickeln von einer Mehrzahl von Lagen, vorzugsweise aus einer Mehrzahl von Papplagen (20, 22, 24, 26, 28, 30, 32, 50, 54) übereinander um einen zylindrischen Kern (12) und Verkleben der Lagen miteinander zur Bildung einer hohlen, vorwiegend aus Pappe bestehenden Röhre auf dem Wickeldon,
- 40 Abnehmen der Röhre (10) von dem Wickeldon und Zerschneiden der Röhre in Längsrichtung zur Bildung von mindestens zwei teilzylindrischen Teilen (102), die jeweils durch eine teilzylindrische Wandung mit einer teilzylindrischen Innenoberfläche und einer teilzylindrischen Außenoberfläche gebildet sind.
- 45 18. Verfahren nach Anspruch 17 mit dem Schritt der Bildung eines Musters von Schlitzten (S) in der teilzylindrischen Außenoberfläche jedes der teilzylindrischen Teile (102), wobei die Schlitzte so konfiguriert sind, dass sie Formwerkzeuge (T) halten.
19. Verfahren nach Anspruch 17 oder 18, bei welcher der Wickelschritt ein spiralförmiges Wickeln der Lagen um den zylindrischen Wickeldon (12) umfasst.
- 50 20. Verfahren nach Anspruch 17, 18 oder 19, bei welchem der Wickelschritt das Wickeln von Lagen mindestens zwei unterschiedlicher Arten umfasst.
- 55 21. Verfahren nach einem der Ansprüche 17 bis 20, bei welchem der Wickelschritt das Wickeln mindestens einer Feuchtigkeitsbarrierenlage enthält.
22. Verfahren nach Anspruch 17, bei welchem der Wickelschritt das Wickeln mindestens einer Feuchtigkeitsbarrieren-

lage in Form eines Laminats aufweist, welches mindestens eine Papierschicht und mindestens eine im Wesentlichen feuchtigkeitsundurchlässige Schicht aufweist.

- 5
23. Verfahren nach Anspruch 22, bei welchem der Wickelschritt das Wickeln von mindestens zwei Feuchtigkeitsbarrierenlagen jeweils in Form des Laminats umfasst.
24. Verfahren nach Anspruch 17, bei welchem der Wickelschritt das Wickeln einer Mehrzahl von Papplagen, deren Feuchtigkeitsgehalt nicht größer als etwa 4 % ist, umfasst.
- 10
25. Verfahren nach Anspruch 24, bei welchem der Wickelschritt weiterhin das Wickeln mindestens einer Feuchtigkeitsbarrierenlage in Form eines Laminats aufweist, das mindestens eine Papierschicht und mindestens eine im Wesentlichen feuchtigkeitsundurchlässige Schicht enthält.

15 **Revendications**

1. Plaque matrice (DB) d'une matrice rotative, comprenant :
- 20 une paroi bombée partiellement cylindrique comportant une surface extérieure partiellement cylindrique et une surface intérieure partiellement cylindrique ;
- caractérisée en ce que** la paroi partiellement cylindrique est constituée au moins principalement d'une pluralité de couches (20, 22, 24, 26, 28, 30, 32, 50, 54) de carton stratifiées ensemble de manière adhésive.
- 25
2. Plaque matrice selon la revendication 1, comprenant en outre une pluralité de fentes (S) formées dans la surface extérieure partiellement cylindrique de la paroi pour recevoir les outils à matrice.
3. Plaque matrice selon la revendication 1 ou 2, dans laquelle la paroi partiellement cylindrique est constituée essentiellement d'une pluralité de couches de carton stratifiées ensemble de manière adhésive.
- 30
4. Plaque matrice selon l'une des revendications précédentes, dans laquelle la surface intérieure partiellement cylindrique présente un diamètre d'environ 482 à 489 mm.
5. Plaque matrice selon la revendication 4, dans laquelle la paroi partiellement cylindrique présente une épaisseur d'environ 12,6 à 13,3 mm.
- 35
6. Plaque matrice selon l'une des revendications précédentes, dans laquelle la pluralité de couches (20, 22, 24, 26, 28, 30, 32, 50, 54) de carton comprend des couches de carton d'au moins deux types différents.
- 40
7. Plaque matrice selon l'une des revendications précédentes, dans laquelle la couche la plus à l'extérieur de la plaque matrice est sensiblement plus fine qu'au moins plusieurs des autres couches.
8. Plaque matrice selon l'une des revendications précédentes, dans laquelle les couches comprennent une première couche de protection contre l'humidité.
- 45
9. Plaque matrice selon la revendication 8, dans laquelle la première couche de protection contre l'humidité comprend un stratifié d'au moins une couche de papier et au moins une couche sensiblement imperméable à l'humidité.
10. Plaque matrice selon la revendication 8, dans laquelle la première couche de protection contre l'humidité est située à proximité d'une surface radialement extérieure de la plaque matrice.
- 50
11. Plaque matrice selon la revendication 10, comprenant en outre une deuxième couche de protection contre l'humidité située à proximité de la surface radialement extérieure de la plaque matrice.
- 55
12. Plaque matrice selon la revendication 9, dans laquelle la première couche de protection contre l'humidité est située à proximité d'une surface radialement intérieure de la plaque matrice.
13. Plaque matrice selon la revendication 12, comprenant en outre une deuxième couche de protection contre l'humidité

EP 1 925 409 B1

située à proximité d'une surface radialement extérieure de la plaque matrice.

5
14. Plaque matrice selon la revendication 13, comprenant en outre une troisième couche de protection contre l'humidité située radialement à l'intérieur des première et deuxième couches de protection contre l'humidité.

15. Plaque matrice selon la revendication 13, dans laquelle il existe un nombre sensiblement plus grand de couches de carton que de couches de protection contre l'humidité.

10
16. Plaque matrice selon la revendication 1, comprenant environ 15 à 25 couches (20, 22, 24, 26, 28, 30, 32, 50, 54) de carton dont la largeur est comprise entre 0,254 mm (0,01 pouce) environ et 0,762 mm (0,03 pouce) environ, la plaque matrice présentant une épaisseur de paroi d'environ 10,2 à 15,2 mm (0,4 à 0,6 pouce).

17. Procédé de fabrication de plaques matrices d'une matrice rotative, consistant à :

15 envelopper une pluralité de couches, composées principalement d'une pluralité de couches (20, 22, 24, 26, 28, 30, 32, 50, 54) de carton, situées les unes sur les autres autour d'un mandrin cylindrique (12) et à coller les couches les unes aux autres pour former un tube creux principalement en carton sur le mandrin ; retirer le tube (10) du mandrin ; et
20 découper le tube dans le sens de la longueur pour former au moins deux parties (102) partiellement cylindriques constituées chacune d'une paroi partiellement cylindrique comportant une surface intérieure partiellement cylindrique et une surface extérieure partiellement cylindrique.

18. Procédé selon la revendication 17, consistant en outre à :

25 former un modèle de fentes (S) dans la surface extérieure partiellement cylindrique de chacune des parties (102) partiellement cylindriques, les fentes étant configurées pour maintenir en place les outils à matrice (T).

30
19. Procédé selon la revendication 17 ou 18, dans lequel l'étape d'enveloppement consiste à envelopper en hélice les couches autour du mandrin cylindrique (12).

20. Procédé selon la revendication 17, 18 ou 19, dans lequel l'étape d'enveloppement consiste à envelopper des couches d'au moins deux types différents.

35
21. Procédé selon l'une des revendications 17 à 20, dans lequel l'étape d'enveloppement consiste à envelopper au moins une couche de protection contre l'humidité.

40
22. Procédé selon la revendication 17, dans lequel l'étape d'enveloppement consiste à envelopper au moins une couche de protection contre l'humidité sous la forme d'un stratifié comportant au moins une couche de papier et au moins une couche sensiblement imperméable à l'humidité.

23. Procédé selon la revendication 22, dans lequel l'étape d'enveloppement consiste à envelopper au moins deux desdites couches de protection contre l'humidité chacune sous la forme dudit stratifié.

45
24. Procédé selon la revendication 17, dans lequel l'étape d'enveloppement consiste à envelopper une pluralité de couches de carton présentant une teneur en humidité d'environ 4 % maximum.

50
25. Procédé selon la revendication 24, dans lequel l'étape d'enveloppement consiste en outre à envelopper au moins une couche de protection contre l'humidité sous la forme d'un stratifié comportant au moins une couche de papier et au moins une couche sensiblement imperméable à l'humidité.

FIG. 1

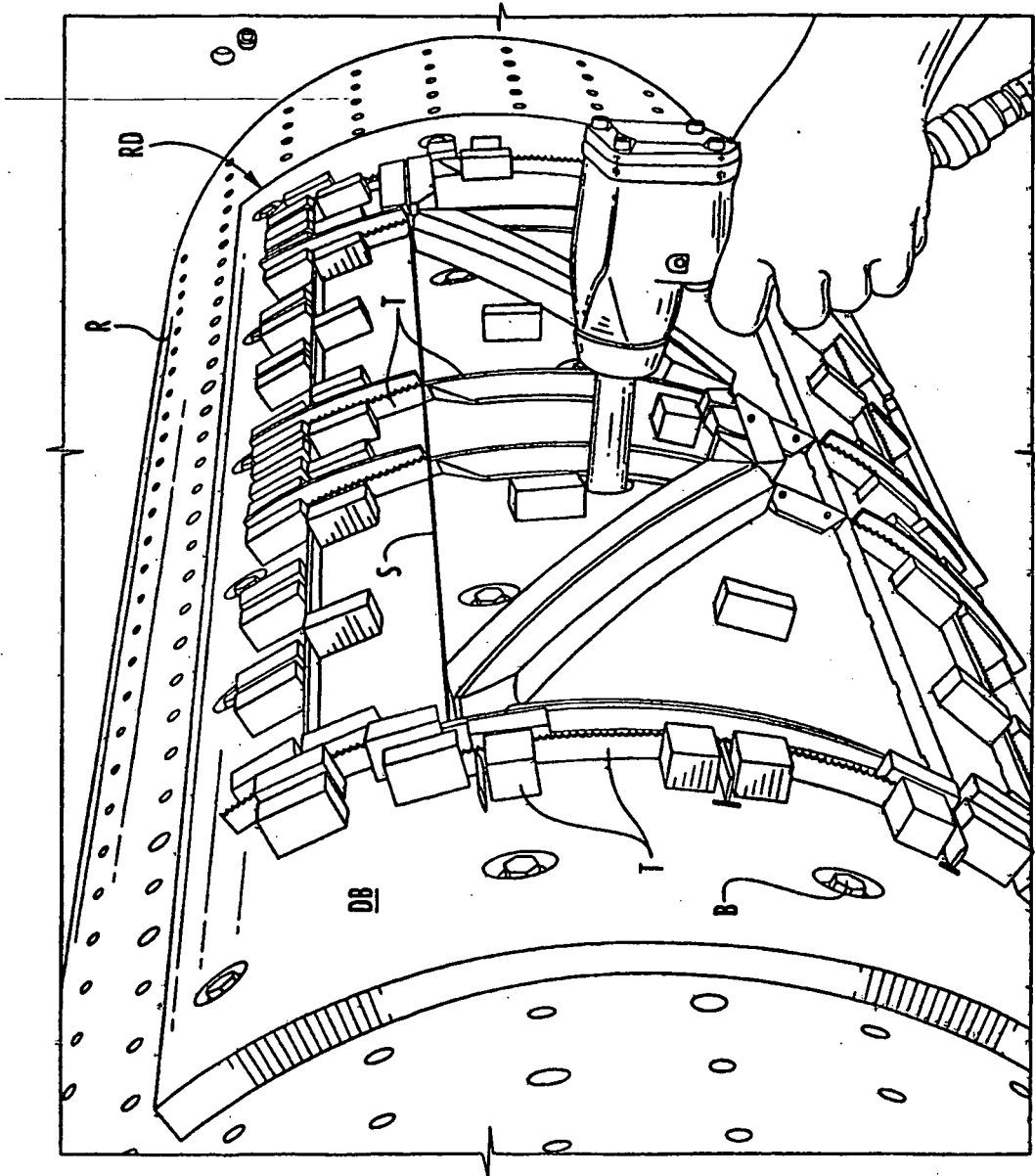

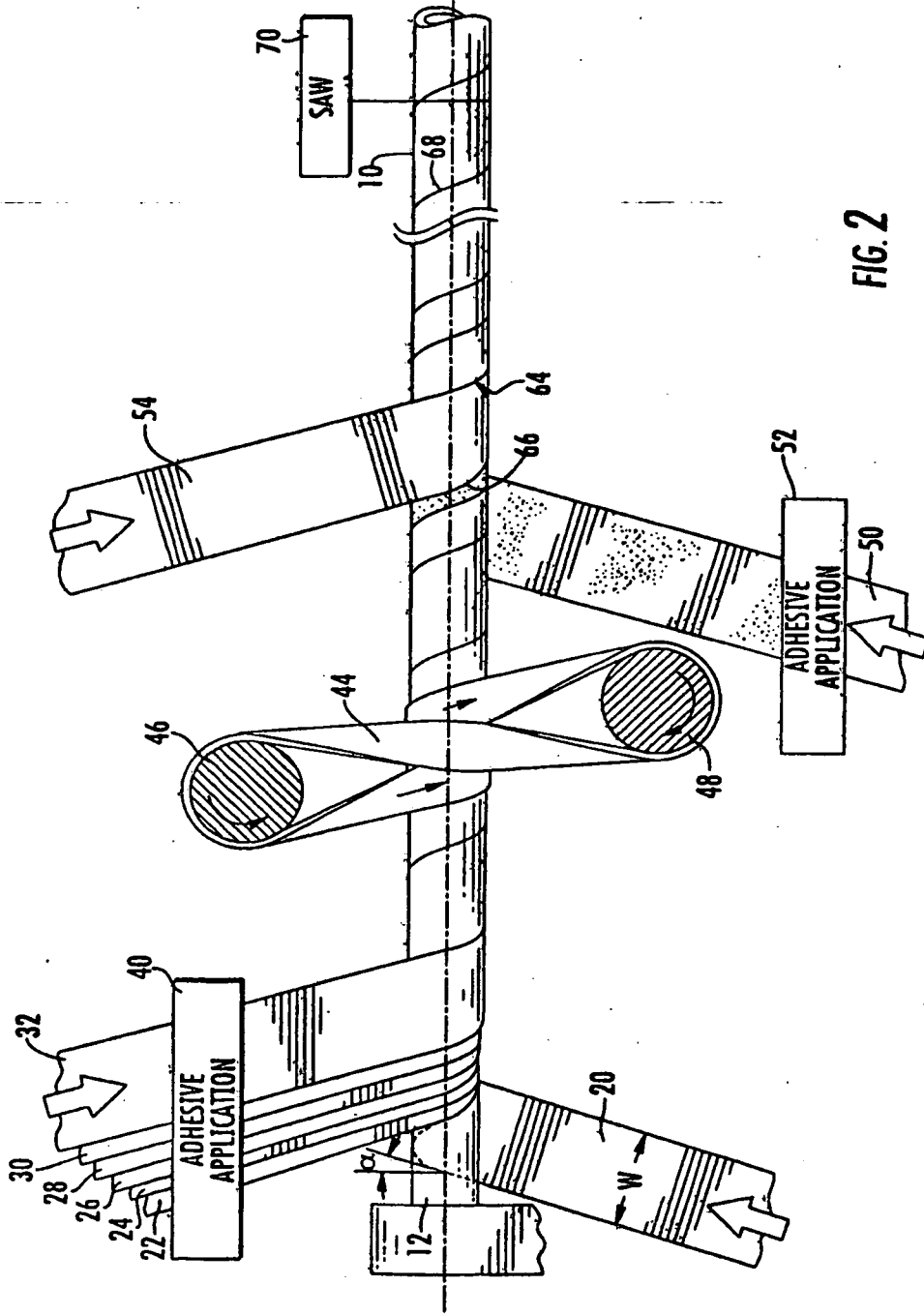

FIG 2

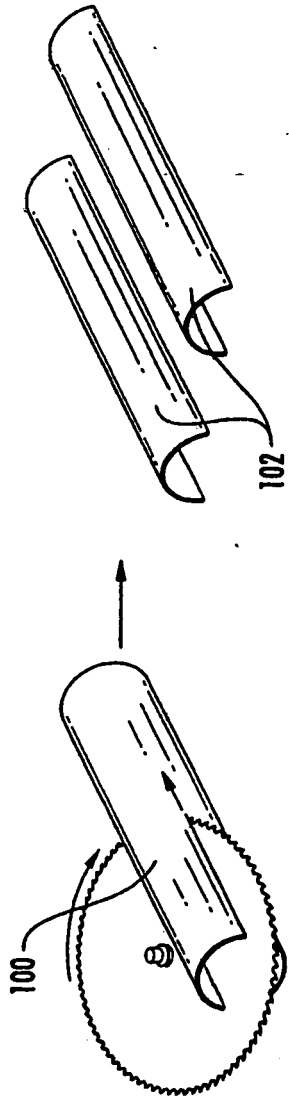

FIG. 3

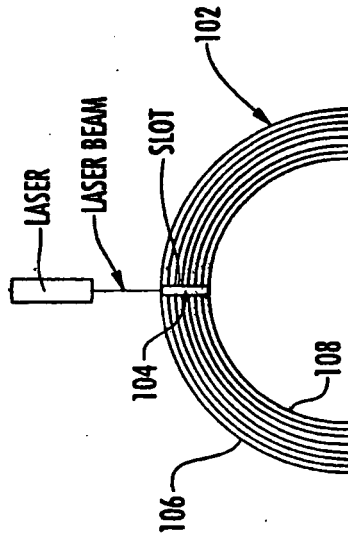

FIG. 4

REFERENCES CITED IN THE DESCRIPTION

This list of references cited by the applicant is for the reader's convenience only. It does not form part of the European patent document. Even though great care has been taken in compiling the references, errors or omissions cannot be excluded and the EPO disclaims all liability in this regard.

Patent documents cited in the description

- US 20010035071 A [0002]
- GB 1221539 A [0002]
- US 5143768 A [0002]