

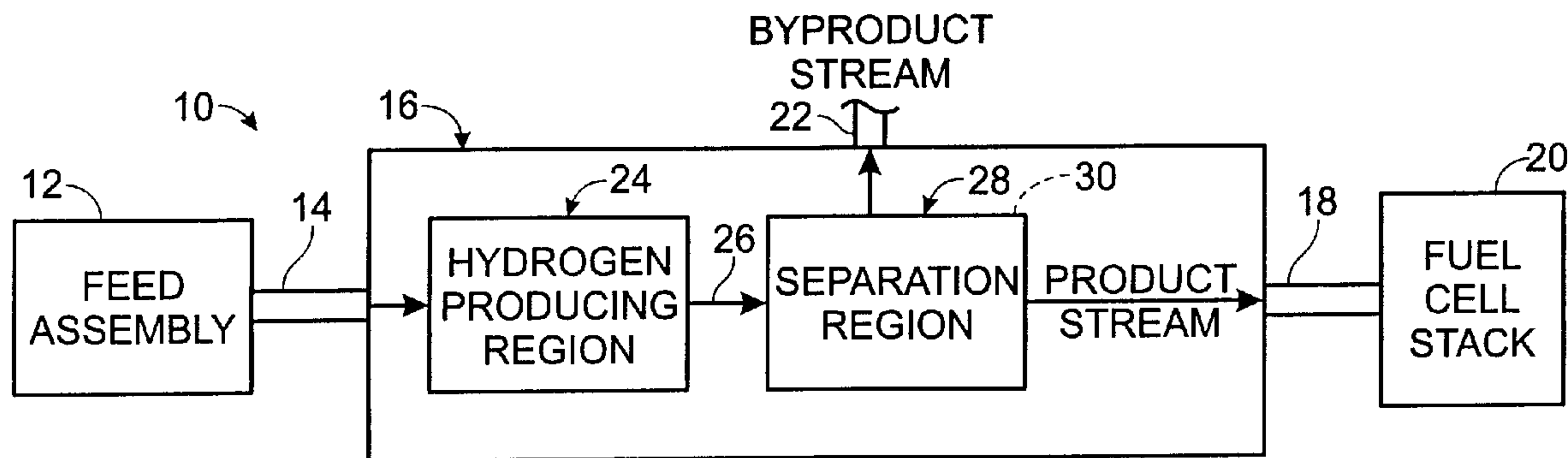

(86) Date de dépôt PCT/PCT Filing Date: 2000/08/11
 (87) Date publication PCT/PCT Publication Date: 2001/02/22
 (45) Date de délivrance/Issue Date: 2003/10/14
 (85) Entrée phase nationale/National Entry: 2001/12/17
 (86) N° demande PCT/PCT Application No.: US 2000/022057
 (87) N° publication PCT/PCT Publication No.: 2001/012539
 (30) Priorités/Priorities: 1999/08/12 (60/148,521) US;
 2000/08/10 (09/636,814) US

(51) Cl.Int.⁷/Int.Cl.⁷ C01B 3/22
 (72) Inventeurs/Inventors:
 EDLUND, DAVID J., US;
 HERRON, THOMAS G., US
 (73) Propriétaire/Owner:
 IDATECH, LLC, US
 (74) Agent: SMART & BIGGAR

(54) Titre : SYSTEME D'ALIMENTATION EN CHARGE VOLATILE ET SYSTEME DE TRAITEMENT DE COMBUSTIBLE INCORPORANT LE PREMIER
 (54) Title: VOLATILE FEEDSTOCK DELIVERY SYSTEM AND FUEL PROCESSING SYSTEM INCORPORATING THE SAME



(57) **Abrégé/Abstract:**

A fuel processing assembly (10) for producing hydrogen gas (18) from volatile feedstock (14). The fuel processing assembly (10) includes a fuel processor (16), such as a steam reformer. The fuel processing assembly (10) further includes a feed assembly (12) for delivering a volatile feedstock (14), such as propane, to the fuel processor (16). In some embodiments, the fuel processing assembly (10) includes a fuel cell stack (20) that includes at least one fuel cell for producing electrical power from hydrogen gas (18) produced by the fuel processor (16).

(12) INTERNATIONAL APPLICATION PUBLISHED UNDER THE PATENT COOPERATION TREATY (PCT)

(19) World Intellectual Property Organization
International Bureau



(43) International Publication Date
22 February 2001 (22.02.2001)

PCT

(10) International Publication Number
WO 01/12539 A1

- (51) International Patent Classification⁷: C01B 3/22
- (21) International Application Number: PCT/US00/22057
- (22) International Filing Date: 11 August 2000 (11.08.2000)
- (25) Filing Language: English
- (26) Publication Language: English
- (30) Priority Data:
60/148,521 12 August 1999 (12.08.1999) US
Not furnished 10 August 2000 (10.08.2000) US
- (71) Applicant (for all designated States except US): IDATECH, LLC [US/US]; P.O. Box 5339, Bend, OR 97708-5339 (US).
- (72) Inventors; and
- (75) Inventors/Applicants (for US only): EDLUND, David, J. [US/US]; 1698 Davenport, Bend, OR 97701 (US). HERRON, Thomas, G. [US/US]; 155 S.E. Windance Court, Bend, OR 97702 (US).
- (74) Agent: D'ASCENZO, David, S.; Kolisch, Hartwell, Dickinson, McCormack & Heuser, P.C., Suite 200, 520 S.W. Yamhill Street, Portland, OR 97204 (US).
- (81) Designated States (national): AE, AG, AL, AM, AT, AU, AZ, BA, BB, BG, BR, BY, BZ, CA, CH, CN, CR, CU, CZ, DE, DK, DM, DZ, EE, ES, FI, GB, GD, GE, GH, GM, HR, HU, ID, IL, IN, IS, JP, KE, KG, KP, KR, KZ, LC, LK, LR, LS, LT, LU, LV, MA, MD, MG, MK, MN, MW, MX, MZ, NO, NZ, PL, PT, RO, RU, SD, SE, SG, SI, SK, SL, TJ, TM, TR, TT, TZ, UA, UG, US, UZ, VN, YU, ZA, ZW.
- (84) Designated States (regional): ARIPO patent (GH, GM, KE, LS, MW, MZ, SD, SL, SZ, TZ, UG, ZW), Eurasian patent (AM, AZ, BY, KG, KZ, MD, RU, TJ, TM), European patent (AT, BE, CH, CY, DE, DK, ES, FI, FR, GB, GR, IE, IT, LU, MC, NL, PT, SE), OAPI patent (BF, BJ, CF, CG, CI, CM, GA, GN, GW, ML, MR, NE, SN, TD, TG).
- Published:
— With international search report.
- For two-letter codes and other abbreviations, refer to the "Guidance Notes on Codes and Abbreviations" appearing at the beginning of each regular issue of the PCT Gazette.

(54) Title: VOLATILE FEEDSTOCK DELIVERY SYSTEM AND FUEL PROCESSING SYSTEM INCORPORATING THE SAME

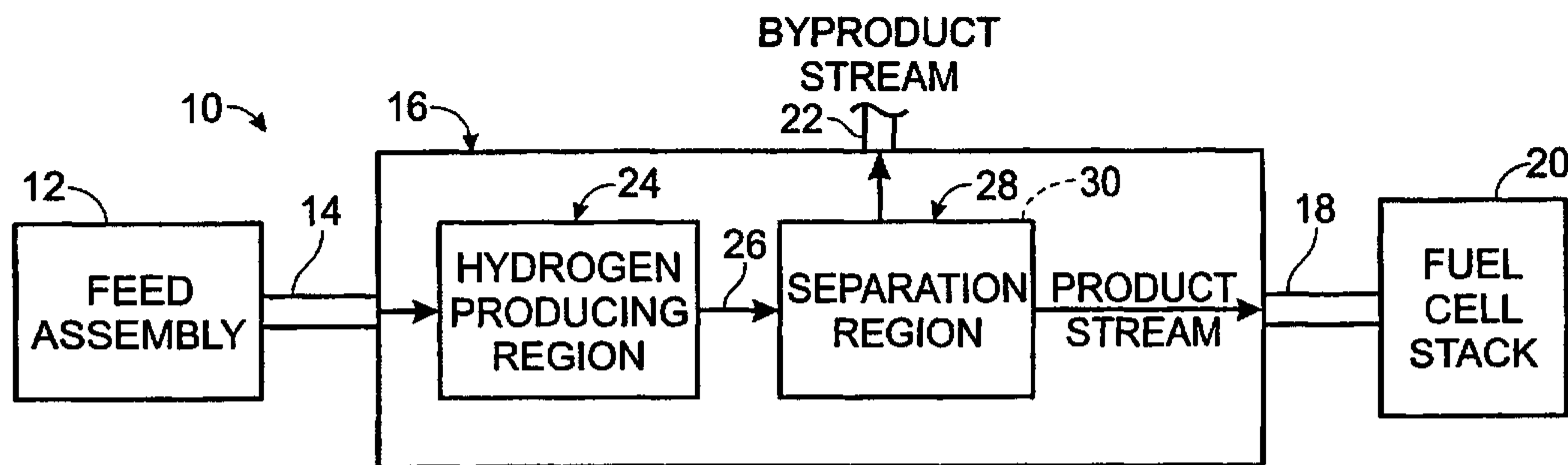

(57) Abstract: A fuel processing assembly (10) for producing hydrogen gas (18) from volatile feedstock (14). The fuel processing assembly (10) includes a fuel processor (16), such as a steam reformer. The fuel processing assembly (10) further includes a feed assembly (12) for delivering a volatile feedstock (14), such as propane, to the fuel processor (16). In some embodiments, the fuel processing assembly (10) includes a fuel cell stack (20) that includes at least one fuel cell for producing electrical power from hydrogen gas (18) produced by the fuel processor (16).

WO 01/12539 A1

PCT/US 00/22057

IPEA/US 12 SEP 2001
Volatile Feedstock Delivery System and Fuel Processing**System Incorporating the Same**Related Application

This application claims priority to co-pending U.S. Provisional
5 Patent Application Serial No. 60/148,521, which was filed on August 12, 1999,
and is entitled "Steam Reforming Method and Apparatus Incorporating a
Volatile Feedstock," and co-pending U.S. Patent Application Serial No.
09/636,814, which was filed on August 10, 2000, and is entitled "Volatile
Feedstock Delivery System and Fuel Processing System Incorporating the
10 Same," and the complete disclosures of which are hereby incorporated by
reference.

Field of the Invention

The invention relates generally to fuel processing systems, and
more specifically to a delivery system for volatile feedstocks and fuel
15 processing systems including the same.

Background and Summary of the Invention

Purified hydrogen is used in the manufacture of many products
including metals, edible fats and oils, and semiconductors and
microelectronics. Purified hydrogen is also an important fuel source for many
20 energy conversion devices. For example, fuel cells use purified hydrogen and
an oxidant to produce an electrical potential. A process known as steam
reforming produces by chemical reaction hydrogen and certain byproducts or
impurities. A subsequent purification process removes the undesirable
impurities to provide hydrogen sufficiently purified for application to a fuel
25 cell.

In a steam reforming process, one reacts steam and a carbon-
containing compound in the presence of a catalyst. Examples of suitable
carbon-containing compounds include, but are not limited to, alcohols (such as
methanol or ethanol) and hydrocarbons (such as methane, propane, gasoline
30 kerosene). Steam reforming requires an elevated operating temperature, e.g.,

between 250 degrees centigrade and 900 degrees centigrade, and produces primarily hydrogen and carbon dioxide, with lesser quantities of carbon monoxide also being formed. Trace quantities of unreacted reactants and trace quantities of byproducts also can result from steam reforming.

5 The invented system includes a fuel processor that produces hydrogen from a variety of feedstocks. One such fuel processor is a steam reformer, which produces purified hydrogen from a carbon-containing feedstock and water. In the invented system, various mechanisms for supplying a volatile feedstock, such as propane, under pressure to the fuel
10 processor are disclosed. In some embodiments, the fuel processing system includes a fuel cell stack that includes at least one fuel cell adapted to produce electrical power from air (oxygen) and hydrogen gas produced by the fuel processor.

Many other features of the present invention will become
15 manifest to those versed in the art upon making reference to the detailed description which follows and the accompanying sheets of drawings in which preferred embodiments incorporating the principles of this invention are disclosed as illustrative examples only.

Brief Description of the Drawings

20 Fig. 1 is a schematic diagram of an illustrative fuel processing system.

Fig. 2 is a schematic diagram of a feed assembly for the fuel processing system of Fig. 1.

25 Fig. 3 is a schematic diagram of a feed assembly adapted to deliver a volatile feedstock to a fuel processor.

Fig. 4 is a schematic diagram of a jacketed reservoir according to the present invention.

Fig. 5 is a schematic diagram of another reservoir according to the present invention.

then used to meet the electric load applied by one or more associated devices, such as vehicles, households, generators, boats, etc. Examples of suitable fuel cells include proton exchange membrane (PEM) fuel cells and alkaline fuel cells.

5 Fuel processor 16 includes a hydrogen producing region 24, in which a hydrogen containing stream, or mixed gas stream, 26 is produced from the feed streams. The hydrogen-containing stream typically contains impurities, and therefore is delivered to a separation region, or purification region, 28, where the stream is purified. In separation region 28, the hydrogen-
10 containing stream is separated into product hydrogen stream 18 and one or more byproduct streams 22 by any suitable pressure-driven separation process. As an illustrative example, separation region 28 may include a membrane module 30, which contains one or more hydrogen permeable metal membranes, such as those discussed herein. Another example of a suitable pressure-
15 separation process is pressure swing absorption (PSA). Therefore, region 28 may alternatively include suitable structure for performing pressure swing absorption.

Region 28 may also be referred to as a purification assembly or separation assembly. Purification assembly 28 is in communication with fuel
20 processor 16 and adapted to receive the mixed gas stream containing hydrogen gas (and other components) from hydrogen producing region 24. Assembly 28 may be contained within fuel processor 16, such as within the housing of the fuel processor. Alternatively, region 28 may be mounted on the housing of the fuel processor. In a further variation, purification assembly 28 may be
25 physically separated from the fuel processor, but still in fluid communication therewith, such as through the use of piping or other fluid transportation lines or mechanisms.

An example of a membrane module formed from a plurality of hydrogen-selective metal membranes is disclosed in U.S. Patent Application
30 Serial No. 09/291,447, which was filed on April 13, 1999, is entitled "Fuel

Processing System,” and the complete disclosure of which is hereby incorporated by reference. In that application, a plurality of generally planar membranes are assembled together into a membrane module having flow channels through which an impure gas stream is delivered to the membranes, a purified gas stream is harvested from the membranes and a byproduct stream is removed from the membranes. Gaskets, such as flexible graphite gaskets, are used to achieve seals around the feed and permeate flow channels.

The thin, planar, hydrogen-permeable membranes are preferably composed of palladium alloys, most especially palladium with 35 wt% to 45 wt% copper. These membranes are typically formed from a thin foil that is approximately 0.001 inches thick. It is within the scope of the present invention, however, that the membranes may be formed from hydrogen-selective metals and metal alloys other than those discussed above and that the membranes may have thicknesses that are larger or smaller than discussed above. For example, the membrane may be made thinner, with commensurate increase in hydrogen flux, such as by the above-described etching process. The hydrogen-permeable membranes may be arranged in any suitable configuration, such as arranged in pairs around a common permeate channel as is disclosed in the incorporated patent applications.

In Fig. 2, an embodiment of feed assembly 12 is shown in more detail. As shown, assembly 12 includes a water delivery system 32 and a volatile feedstock delivery system 34. Each delivery system 32 and 34 includes associated pumps, transportation lines and the like to receive and deliver a stream of the appropriate feedstock to fuel processor 16. The systems may selectively receive the feedstock from an external source, such as by a fluid transportation line 36. Alternatively, or additionally, the systems may include a reservoir 38 adapted to store a selected volume of the feedstock. The reservoirs 38 may be recharged either by replacing the reservoir with a full reservoir or by refilling the reservoir by any suitable method, such as by using a fluid transportation line connected to an external source. Systems 32 and 34

deliver water and carbon-containing feed streams 40 and 42 to fuel processor 16. It should be understood that delivery system 34 may be used to deliver volatile carbon-containing feedstocks for use other than by steam reformers.

As discussed, suitable feedstocks for fuel processing assembly 16 include carbon-containing compounds such as hydrocarbons and alcohols. Some carbon-containing feedstocks are volatile. Examples of volatile hydrocarbon feedstocks include propane, butane, propylene, butylene and mixtures thereof, such as LPG.

In Fig. 3, a delivery system 34 for a volatile carbon-containing feedstock is shown. System 34 is adapted to deliver stream 42 to fuel processor 16 at an elevated pressure. Steam reforming at elevated pressure is necessary to the integrated hydrogen-purification method that is based upon a hydrogen-selective membrane or other suitable pressure-driven separation process. In particular, it is preferable that steam reforming be conducted at 100 psig to 300 psig. Although propane is commonly stored as a compressed liquified gas, the vapor pressure of propane is very dependent on the temperature of the liquified gas. For instance, the vapor pressure curve of propane as a function of temperature is shown in Fig. 7. As shown, at 0° F the vapor pressure of propane is about 29 psig, whereas at 70° F the vapor pressure is 110 psig and at 130° F the vapor pressure is 258 psig (Handbook of Compressed Gases, 3rd Edition, pp. 450-451). This large variability in the vapor pressure of propane as a function of temperature presents difficulty in admitting propane into the steam-reforming region of the fuel processor at a specific elevated pressure within the range of 100 psig to 300 psig, or other pressure range at which the pressurized volatile feedstock will be used.

As shown in Fig. 3, system 34 includes a volatile feedstock supply assembly 35 that provides a source of a volatile, carbon-containing feedstock for use in delivery system 34. Supply assembly is shown including a primary reservoir 38 that is charged with a volume of a volatile carbon-containing feedstock 44, such as those described above. Reservoir 38 may be

recharged through any suitable mechanism, including refill by a supply line 36 connected to an external source, by replacement with a full reservoir, and by delivery of a volume of feedstock to refill the reservoir. It is within the scope of the invention that delivery system 34 may be implemented without reservoir 5 38, such as when the delivery system is in communication with an external supply of feedstock.

In the subsequent discussion, system 34 will be described as a propane delivery system, however, it should be understood that the system may be used with any suitable volatile feedstock. A pump 46 draws a stream 48 of 10 propane from primary reservoir 38 and delivers the stream in alternating fashion via feed valve assembly 50 to a plurality of heated supply reservoirs 52, each of which is adapted to store a volume of propane 54. For purposes of illustration, two supply reservoirs 52a and 52b are shown. It should be understood that additional reservoirs 52 may be used. Furthermore, a single 15 reservoir 52 may be used, however, in such an embodiment the delivery of feedstock by system 34 will be intermittent as the reservoir is recharged and if necessary, heated. In embodiments of the delivery system where pressurized feedstock is available from an external supply, pump 46 may be omitted.

Liquid propane stored within supply reservoirs 52a and 52b is 20 heated to raise the vapor pressure of the propane to a sufficiently high pressure to supply liquid propane directly to the fuel processor at the desired operating pressure. For instance, raising the temperature of the liquid propane within the supply reservoir to 60° C (140° F) will cause the propane vapor pressure to increase to 300 psig.

25 Propane supply reservoirs 52a and 52b are preferably optimized such that while one supply reservoir is supplying pressurized liquid propane to the fuel processor the other supply reservoir is being refilled from the master storage reservoir 38. Thus, feed valve assembly 50 properly directs propane to the supply reservoir that requires filling. Valve assembly 50 may include any 30 suitable number and type of valve, or structure for controlling fluid flow. An

example of a suitable valve assembly 50 is a three-way valve. When a particular supply reservoir 52 is filled, an exhaust vent assembly 53, such as valve 56, is opened to allow the displaced vapor from the supply reservoir to return to the master storage reservoir 38 via transportation lines 55. Preferably, valve 56 is opened only during the filling operation. In embodiments of delivery system 34 that do not include reservoir 38, the vent assembly may vent the vapor to the atmosphere or communicate with suitable transportation lines to transport the vapor to another suitable location for storage, combustion or use.

10 It should be understood that the time required for a reservoir to dispense its supply of feedstock may not necessarily correspond to the time required to fill the reservoir. Therefore, there may be times that one reservoir is dispensing feedstock and another reservoir is filled with preheated feedstock, which is ready to be dispensed after the currently dispensing reservoir is
15 depleted of available feedstock.

A downstream, or delivery, valve assembly 58, such as another three-way valve, directs the flow of pressurized liquid propane from the appropriate supply reservoir 52 to the fuel processor as stream 42. Preferably, valve assemblies 50 and 58 operate in unison to ensure that one supply
20 reservoir is being refilled while the other is providing propane stream 42 to the fuel processor. As discussed above, however, there may be times when the reservoir supplying propane (or another volatile carbon-containing feedstock) to the fuel processor still has a volume of propane to be supplied even though the other reservoir is already refilled and preheated.

25 As discussed, supply reservoirs 52 are maintained at elevated temperatures. The necessary heat energy required to heat the liquid propane within the supply reservoir is obtained from any suitable heat source. For example, system 34 may include a heating assembly 67 adapted to heat the reservoirs to a desired temperature. Heating assembly 67 may include a heated
30 fluid stream 68 that heats the reservoirs through heat exchange. As shown,

stream 68 passes through conduits 71 in reservoirs 52. In Fig. 3, a heating valve assembly 64, such as another three-way valve 65 is shown adapted to direct stream 68 between the two supply reservoirs so that only the reservoir that is providing propane to the fuel processor is being heated. Alternatively, the valve assembly may selectively apportion the heating fluid stream between the reservoirs, such as to maintain the dispensing reservoir at a desired delivery temperature while also providing heat to another reservoir to preheat the feedstock being supplied to the reservoir. Stream 68 may form part of a cooling fluid loop 70, in which case the stream is returned via stream 72 for reheating after heat exchange with one or more of reservoirs 52. Alternatively, the stream may be exhausted or sent to a downstream device for disposal, use, storage or the like.

An example of a suitable heating fluid stream 68 is a heated cooling fluid stream discharged from fuel cell stack 20. This stream, which typically contains water, is often obtained at 60° C by virtue of the operating characteristics of many fuel cells. After transferring heat to the propane supply reservoir, stream 68 is returned to the fuel-cell cooling loop. Using the fuel-cell cooling fluid in this manner to heat the propane in the supply reservoir has the added benefit in that the vaporizing propane serves to remove heat from the fuel-cell cooling fluid. Preferably, the supply reservoir is not heated during the refilling operation to minimize the heat that pump 46 must work against to refill the supply reservoirs.

Another suitable heating stream 68 is a heated exhaust stream from fuel processor 16. While stream 68 is shown in Fig. 3 passing through reservoirs 52, it is within the scope of the present invention that stream 68 may alternatively be delivered to a shell, or jacket, 74 that at least partially, or completely, surrounds one or more of the reservoirs, such as shown in Fig. 4. Other sources of heat can also serve to heat the propane within the supply reservoirs. For instance, electric resistance heaters, burners and the exhaust stream from a combustion chamber or combustion unit may be used.

Resistance heaters may heat the exterior of the reservoirs, and/or include one or more heating rods that extend into the reservoirs. Schematically illustrated in Fig. 5 is a reservoir 52 being heated by an electric resistance heater 75 that includes one or more heating rods 77 that extend into the reservoir. The number and configuration of the rods may vary, and alternatively, the resistance heater may heat the shell of reservoir as opposed to heating the fluid within the reservoir directly.

Delivery system 34 may further include a control system 80 adapted to control the operation of the volatile feedstock delivery system. Control system 80 includes a controller 82 that communicates with the valve assemblies, pump assemblies and suitable sensors within the delivery system. For example, control system 80 is schematically illustrated in Fig. 6, in which the communication between controller 82 and various components of fuel processing and delivery systems is shown. It should be understood that communication with all of these components is not required and that the controller may communicate with other components not shown in Fig. 6, as well as enabling communication between components via the control system.

Illustrative examples of sensors that may be used include one or more level and temperature sensors on reservoirs 52, flow meters on the fluid streams, and temperature sensors on heated fluid stream 68. It should be understood that these sensors are but illustrative examples and that a particular embodiment of the system described herein may include some or all of these sensors, as well as including one or more other sensors. Furthermore, the controller may be a separate microprocessor or other suitable device that receives measured values from the delivery system and actuates the system responsively, such as if one or more of the measured values exceed selected thresholds. Similarly, the controller may be directed associated with the sensors, which may include microprocessors adapted to direct a particular operation or operations should the measured variable or value exceed a stored or user-inputted threshold value or range of values.

Communication may be either one- or two-directional, with the controller receiving information from the communicating unit and/or directing the operation of that unit or another portion of the fuel processing system responsive to the received information. The communication described herein
5 may be via any suitable linkage for sending and/or receiving signals between the associated elements of the system. Any suitable mechanical linkage, or wired or wireless electronic linkage may be used.

By comparing the measured values to user-inputs or stored values, the controller then selectively controls the operation of the delivery
10 system. For example, if a measured value for a particular variable exceeds (either above or below) a threshold value or range of acceptable values, the controller may responsively actuate one or more components of the delivery system to bring the measured value, or variable, back to an acceptable value. For example, when the level of fluid in a particular reservoir falls below a
15 selected threshold, such as indicated to controller 82 by a level sensor associated with that reservoir or a flow meter that measures the volume of fluid dispensed from that reservoir, the controller may actuate valve assembly 50 to cause feedstock supply assembly 35 to deliver more of the feedstock to that reservoir. Similarly, the controller may actuate vent assembly 53 to allow the
20 displacement of vapor from the reservoir as the reservoir is filled. Because the reservoir that had been dispensing feedstock is now being refilled, controller 82 may actuate valve assembly 58 to cause another reservoir to begin dispensing feedstock. Controller 82 may also actuate heating assembly 67, including valve assembly 65 to allocate the supply of heating fluid between the
25 reservoirs.

When a reservoir being filled reaches its selected full volume, as measured for example by a suitable level sensor, the controller 82 will actuate supply assembly 35 to stop the delivery of feedstock to the reservoir and vent assembly 53 to stop the displacement of exhaust vapor from the reservoir.
30 Once the volatile carbon-containing feedstock in the reservoir reaches a

selected temperature, such as indicated by a suitable thermocouple or temperature sensor, the controller may actuate heating assembly 67 to change or even stop the delivery of heat to that reservoir. Should the temperature of the feedstock in the reservoir fall below a selected minimum temperature or exceed a selected maximum temperature, controller 82 would again actuate heating assembly 63 to bring the temperature back to an acceptable value or range of values.

Industrial Applicability

The fuel processing system described herein is applicable in any situation where a volatile carbon-containing feedstock is to be delivered under pressure. It is particularly applicable in steam reforming applications in which hydrogen gas is produced from water and a volatile carbon-containing feedstock.

It is believed that the disclosure set forth above encompasses multiple distinct inventions with independent utility. While each of these inventions has been disclosed in its preferred form, the specific embodiments thereof as disclosed and illustrated herein are not to be considered in a limiting sense as numerous variations are possible. The subject matter of the inventions includes all novel and non-obvious combinations and subcombinations of the various elements, features, functions and/or properties disclosed herein. Where the claims recite "a" or "a first" element or the equivalent thereof, such claims should be understood to include incorporation of one or more such elements, neither requiring nor excluding two or more such elements.

The following claims recite certain combinations and subcombinations that are directed to one of the disclosed inventions and are believed to be novel and non-obvious. Inventions embodied in other combinations and subcombinations of features, functions, elements and/or properties may be claimed through amendment of the present claims or presentation of new claims in this or a related application. Such amended or new claims, whether they are directed to a different invention or directed to the

same invention, whether different, broader, narrower or equal in scope to the original claims, are also regarded as included within the subject matter of the inventions of the present disclosure.

PCT/US 00/22057

IPEA/US 12 SEP 2001

WE CLAIM:

1. A volatile feedstock delivery system, comprising:
a plurality of heated reservoirs adapted to receive and store under pressure a volume of a volatile carbon-containing feedstock;
a delivery system adapted to selectively deliver an output stream containing feedstock from a selected one of the reservoirs; and
a heating assembly adapted to heat the plurality of reservoirs.
2. The system of claim 1, wherein the heating assembly is adapted to heat the reservoirs by heat exchange with a heated fluid stream.
3. The system of claim 2, wherein the heating assembly is adapted to selectively apportion the heated fluid stream between the plurality of reservoirs.
4. The system of claim 3, wherein the heating assembly is adapted to selectively apportion the heated fluid stream between the plurality of reservoirs to control the pressure of the volatile carbon-containing feedstock in the reservoirs.
5. The system of claim 1, wherein the heating assembly includes at least one electric resistance heater adapted to heat the reservoirs.
6. The system of claim 1, wherein the heating assembly includes a burner adapted to produce an exhaust stream, and further wherein the heating assembly is adapted to heat the reservoirs through heat exchange with the exhaust stream from the burner.

NO. 02371657
IPEA/UC 12 SEP 2001

7. The system of claim 1, wherein at least one of the reservoirs includes at least one conduit extending into the reservoirs through which a heated fluid stream may flow.

8. The system of claim 7, wherein the heating assembly is adapted to heat at least one of the reservoirs by passing a heated fluid stream through the at least one conduit.

9. The system of claim 1, wherein at least one of the reservoirs includes a shell at least partially surrounding the reservoir and spaced-apart from that reservoir to define a cavity, and further wherein the heating assembly is adapted to heat the at least one of the reservoirs by delivering a heated fluid stream to the cavity.

10. The system of claim 1, further including a supply assembly adapted to selectively deliver the volatile carbon-containing feedstock to the plurality of reservoirs.

11. The system of claim 10, wherein the supply assembly includes a vent assembly in communication with each of the plurality of reservoirs, and further wherein the vent assembly is adapted to selectively vent the corresponding reservoir when the supply assembly delivers the volatile carbon-containing feedstock to the reservoir.

12. The system of claim 11, wherein the vent assembly is disposed to prevent venting of each of the reservoirs except when the supply assembly is delivering the volatile carbon-containing feedstock to the reservoirs.

PCT/US 00/22057
IPEA/US 12 SEP 2001

13. The system of claim 1, further including a supply assembly adapted to deliver the volatile carbon-containing feedstock to the reservoirs.

14. The system of claim 13, wherein the supply assembly includes a supply reservoir adapted to store a volume of the volatile carbon-containing feedstock for selective delivery to the plurality of reservoirs.

15. The system of claim 1, further including a control system adapted to control the pressure of the volatile carbon-containing feedstock in the reservoirs.

16. The system of claim 15, wherein the control system is adapted to control the operation of the heating assembly.

17. The system of claim 15, wherein the control system is adapted to control the reservoir from which the delivery system draws the output stream.

18. The system of claim 1, further including a fuel processor adapted to receive the output stream and to produce a product stream containing hydrogen gas therefrom.

19. The system of claim 18, wherein the fuel processor includes a steam reformer.

20. The system of claim 18, further including a fuel cell stack adapted to receive the product stream and including at least one fuel cell adapted to produce electrical power therefrom.

IPEA/US 12 SEP 2001

21. A fuel processing system, comprising:
- a fuel processor adapted to produce a product stream containing hydrogen gas from a feedstock;
 - a feed assembly adapted to deliver the feedstock at a selected pressure to the fuel processor, wherein the feed assembly includes a volatile feedstock feed system, comprising:
 - a plurality of reservoirs adapted to receive and store under pressure a volume of a volatile carbon-containing feedstock;
 - a delivery system including a delivery valve assembly adapted to selectively deliver a feed stream containing volatile carbon-containing feedstock from a selected one of the reservoirs at a pressure at least as great as the selected pressure;
 - a supply system including a supply valve assembly adapted to selectively fill the reservoirs with the volatile carbon-containing feedstock.
 - a heating assembly adapted to selectively heat the plurality of reservoirs to maintain the pressure of the volatile carbon-containing feedstock in the reservoirs at or above the selected pressure.

22. The system of claim 21, wherein the supply and delivery valve assemblies are adapted to selectively deliver volatile carbon-containing feedstock from one of the reservoirs while supplying volatile carbon-containing feedstock to another one of the reservoirs.

23. The system of claim 21, further including a fuel cell stack adapted to receive the product stream and including at least one fuel cell adapted to produce electrical power therefrom.

24. The system of claim 21, further including a control system adapted to control the pressure of the volatile carbon-containing feedstock in the feed stream.

PCT/US 00/22057

IPEA/US 12 SEP 2001

25. The system of claim 24, wherein the control system is adapted to control the operation of the heating assembly to control the temperature of the reservoirs.

26. The system of claim 24, wherein the control system is adapted to control the operation of the supply system to control the volume of the volatile carbon-containing feedstock in the reservoirs.

27. The system of claim 24, wherein the control system is adapted to control the operation of the delivery system to control the delivery of the feed stream.

28. The system of claim 24, wherein the control system includes a controller in communication with a sensor assembly comprising at least one sensor adapted to measure an operating parameter of the feed system.

29. The system of claim 28, wherein the sensor assembly includes temperature sensors adapted to measure the temperature in the reservoirs.

30. The system of claim 28, wherein the sensor assembly includes level sensors adapted to measure the volume of the volatile carbon-containing feedstock in the reservoirs.

31. The system of claim 28, wherein the sensor assembly includes pressure sensors adapted to measure the pressure of the volatile carbon-containing feedstock in the reservoirs.

PCT/US 00/22057

IPEA/US 12 SEP 2001

32. The system of claim 1, wherein the carbon-containing feedstock is gaseous at ambient temperatures and pressures.

33. The system of claim 32, wherein the selected pressure is sufficiently high that the volatile carbon-containing feedstock stored in the reservoirs includes a liquid phase.

34. The system of claim 33, wherein the selected pressure is at least 100 psig.

35. The system of claim 33, wherein the heating assembly is adapted to heat the reservoirs to a temperature such that the vapor pressure of the carbon-containing feedstock is in the range of approximately 100-300 psig.

36. The system of claim 1, wherein the carbon-containing feedstock includes at least one of propane, butane, propylene, butylene.

37. The system of claim 1, wherein the output stream is at least substantially a liquid stream.

38. The system of claim 1, wherein the output stream is a liquid stream.

39. The system of claim 15, wherein the control system includes a controller and a sensor assembly comprising at least one sensor adapted to measure a value of an operating parameter of the delivery system.

40. The system of claim 39, wherein the controller includes a microprocessor.

22057
19 SEP 2007

41. The system of claim 39, wherein the controller is adapted to control the operation of the feed assembly responsive at least in part to inputs from the sensor assembly.

42. The system of claim 39, wherein the controller is in communication with the sensor assembly and is adapted to compare the measured value with at least one of a stored value and a user input and to control the operating of the delivery system at least partially in response thereto.

43. The system of claim 21, wherein the carbon-containing feedstock is gaseous at ambient temperatures and pressures.

44. The system of claim 43, wherein the selected pressure is sufficiently high that the volatile carbon-containing feedstock stored in the reservoirs includes a liquid phase.

45. The system of claim 44, wherein the selected pressure is at least 100 psig.

46. The system of claim 44, wherein the heating assembly is adapted to heat the reservoirs to a temperature such that the vapor pressure of the carbon-containing feedstock is in the range of approximately 100-300 psig.

47. The system of claim 21, wherein the carbon-containing feedstock includes at least one of propane, butane, propylene, butylene.

48. The system of claim 21, wherein the feed stream is at least substantially a liquid stream.

~~00/42057~~
IPEA/UC 12 SEP 2001

49. The system of claim 21, wherein the feed stream is a liquid stream.

50. The system of claim 24, wherein the control system includes a controller and a sensor assembly comprising at least one sensor adapted to measure a value of an operating parameter of the feed assembly.

51. The system of claim 50, wherein the controller includes a microprocessor.

52. The system of claim 50, wherein the controller is adapted to control the operation of the feed assembly responsive at least in part to inputs from the sensor assembly.

53. The system of claim 50, wherein the controller is in communication with the sensor assembly and is adapted to compare the measured value with at least one of a stored value and a user input and to control the operating of the feed assembly at least partially in response thereto.

Fig. 1

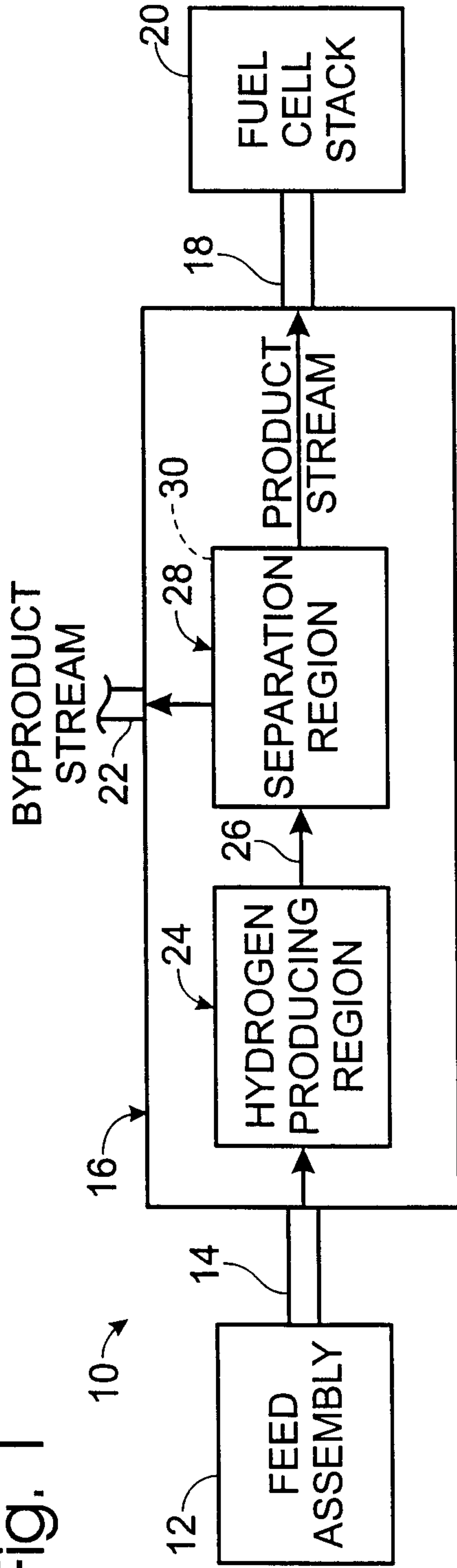

Fig. 2

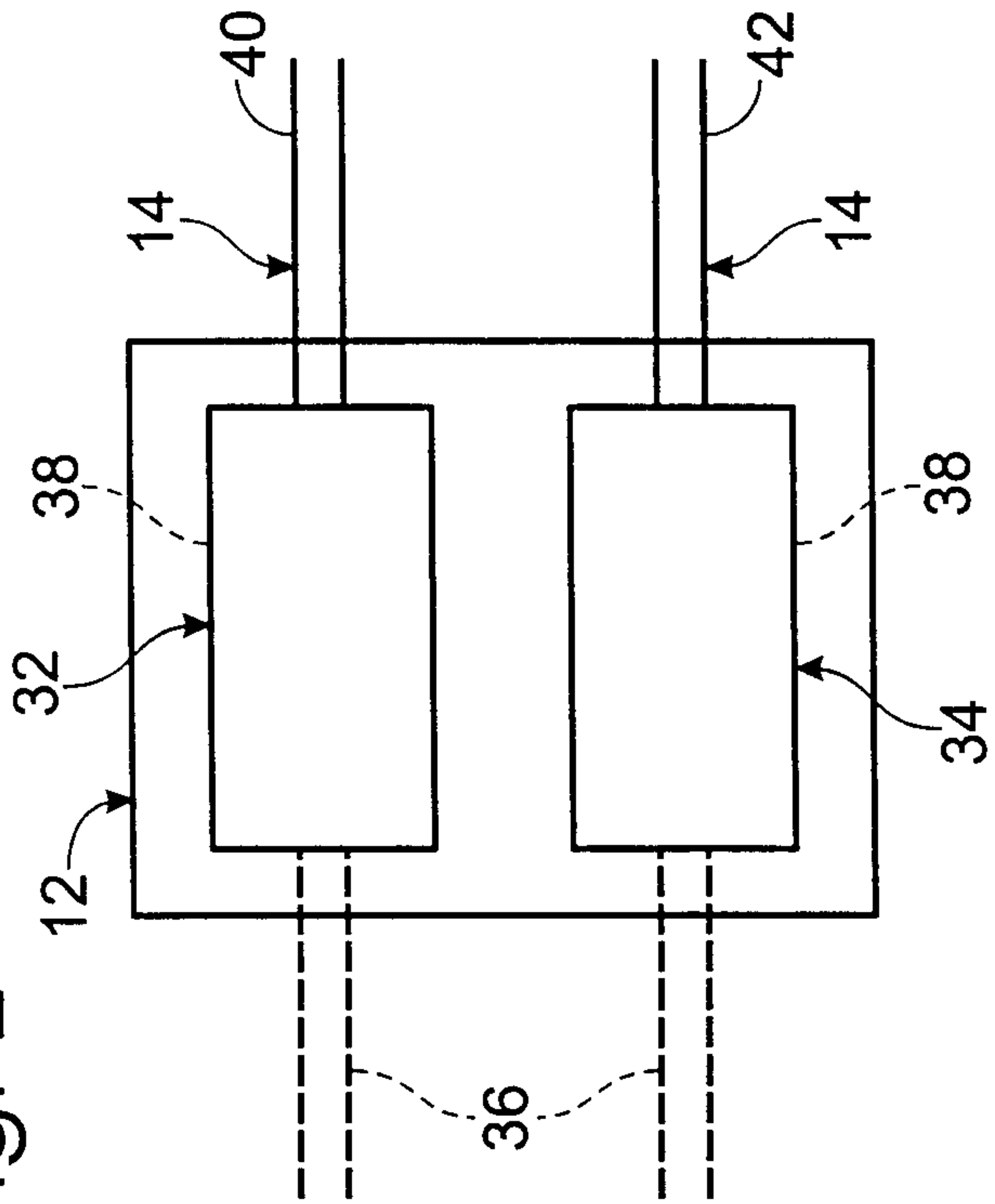
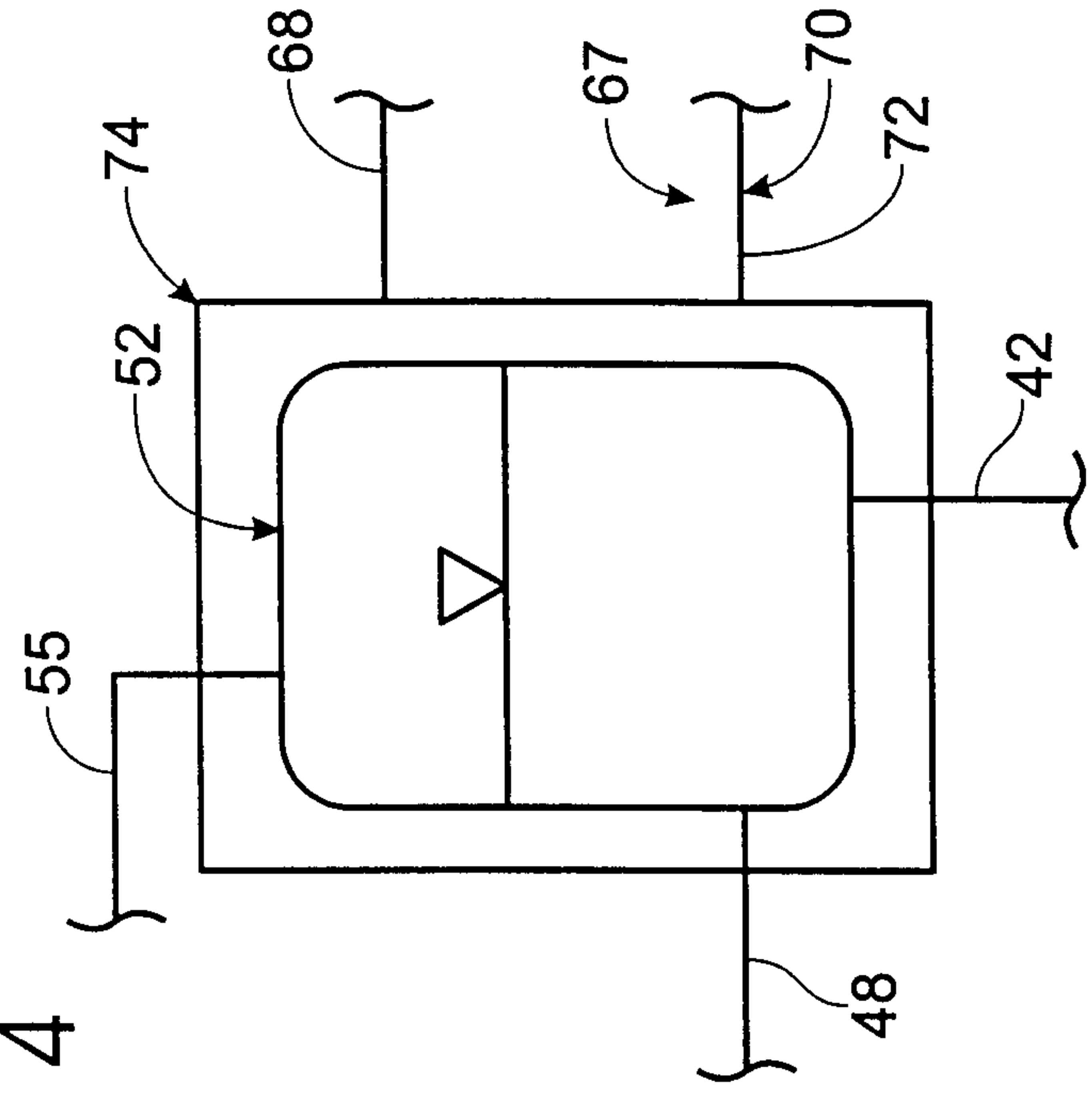

Fig. 4



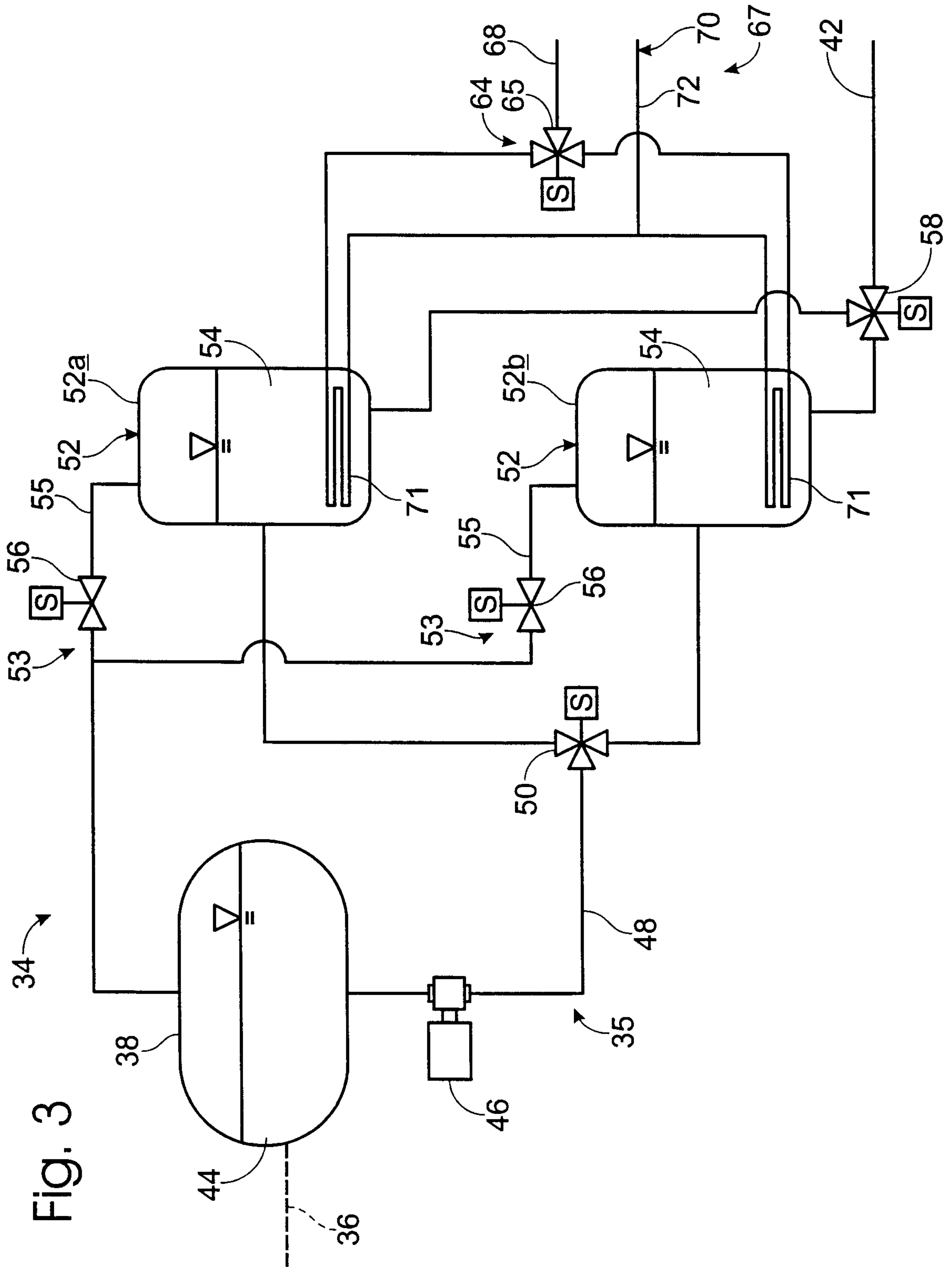

Fig. 3

Fig. 5

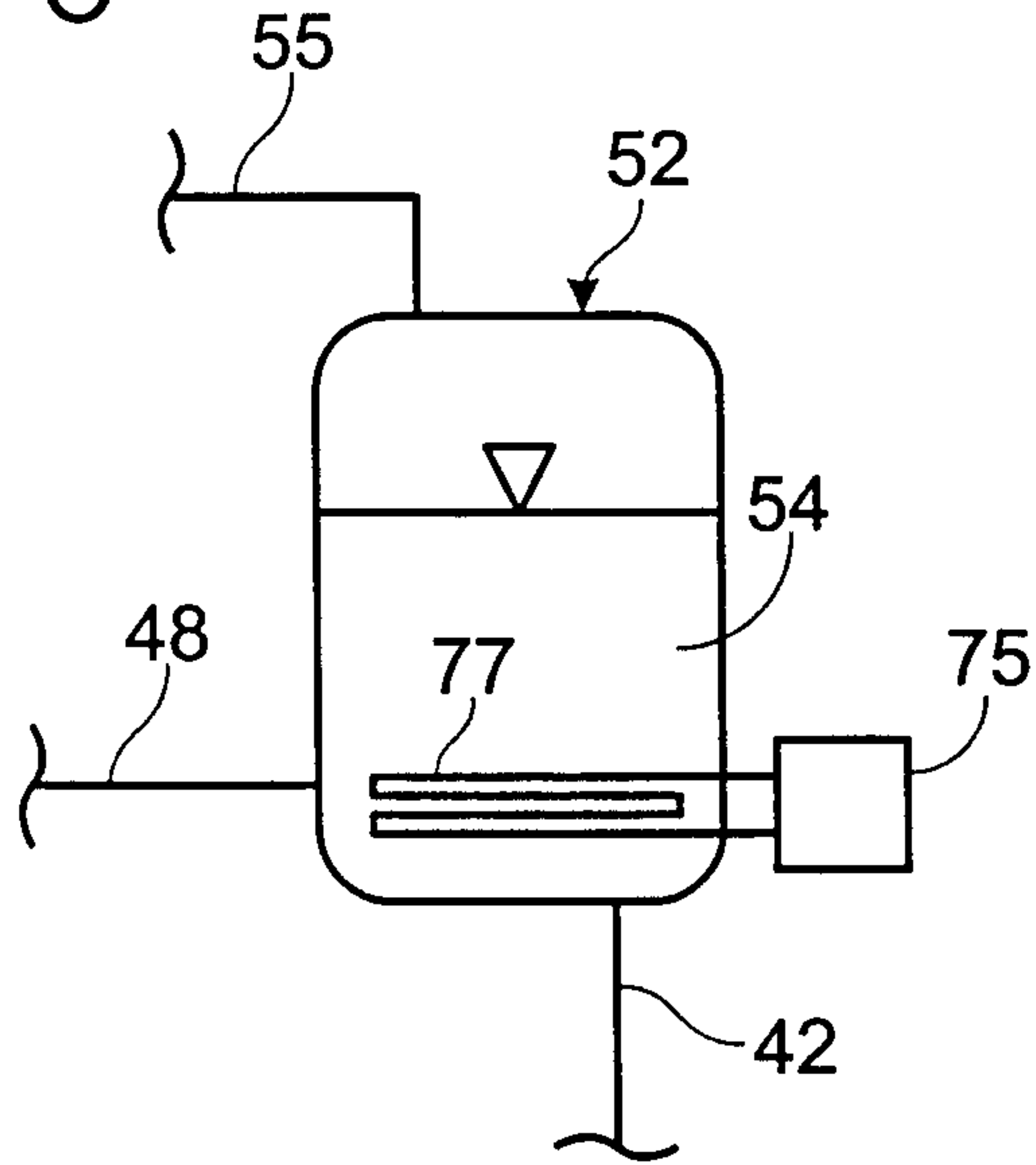
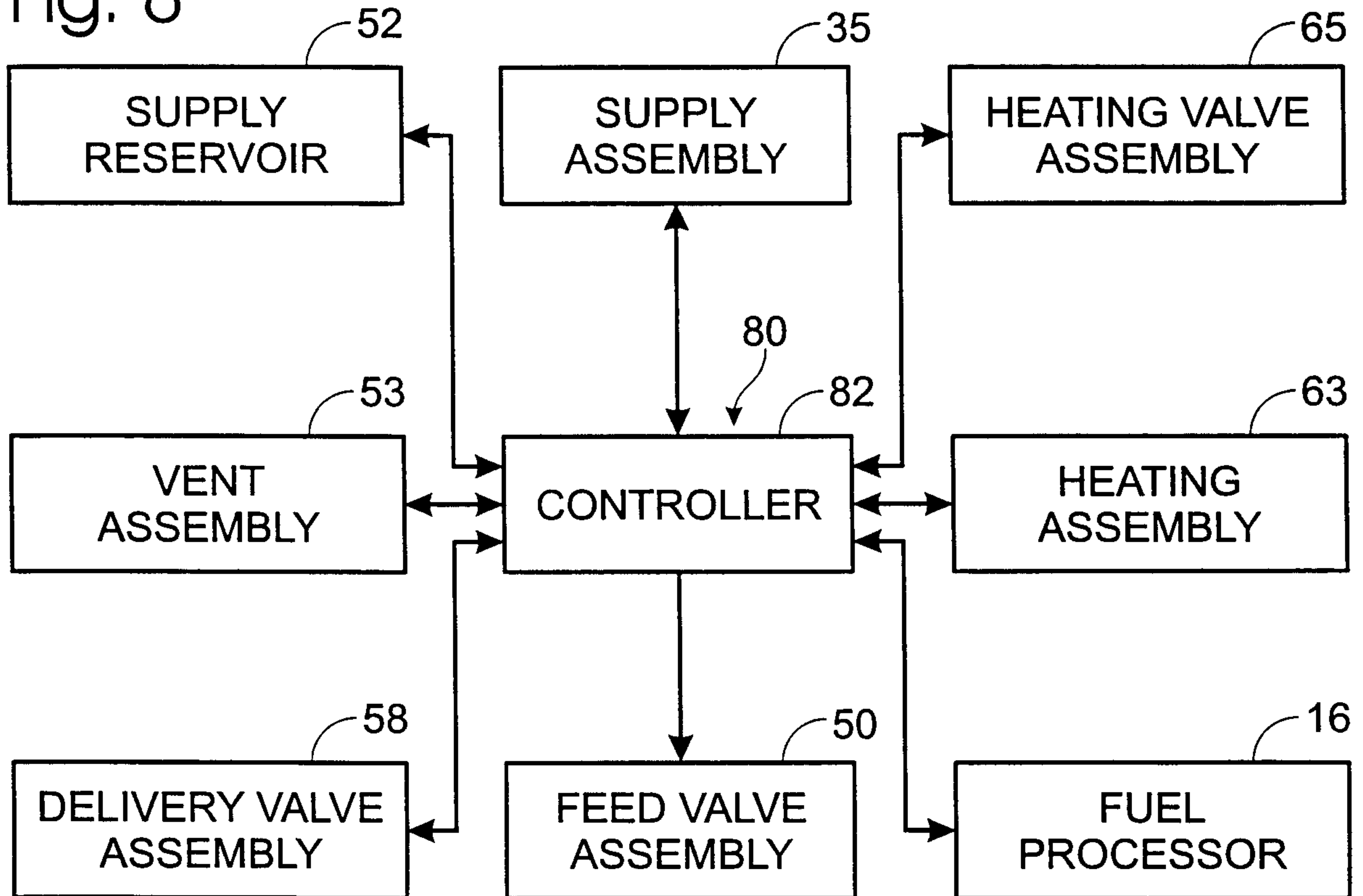

Fig. 6



4/4

Fig. 7

