

*S. Hinton,
Gage Lathe.*

N^o 57,716.

Patented Sep. 4, 1866.

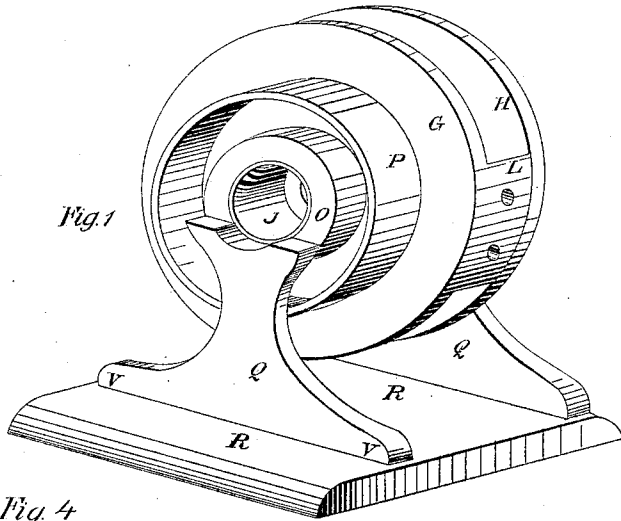

Fig. 1

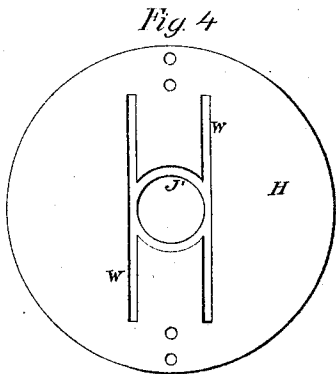

Fig. 4

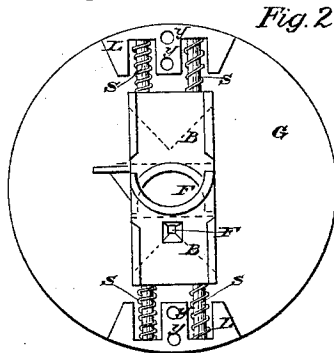

Fig. 2

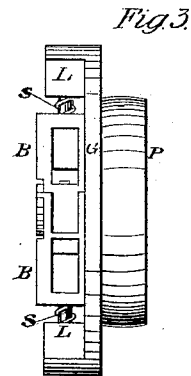

Fig. 3

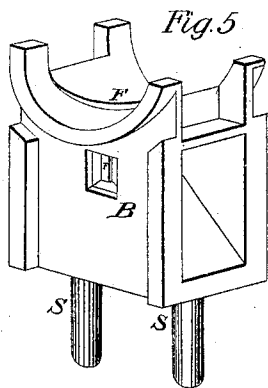

Fig. 5

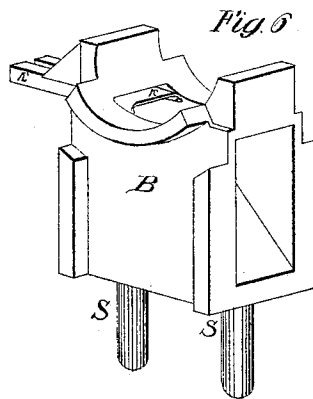

Fig. 6

*Witnesses
Ephraim D. Smith,
Chas. A. Elliot.*

*Inventor
Spencer Hinton
By Messrs C
Attorneys*

UNITED STATES PATENT OFFICE

SPENCER HINTON, OF JACKSON, MICHIGAN, ASSIGNOR TO WITHINGTON,
COOLEY & CO., OF SAME PLACE.

IMPROVEMENT IN TURNING-LATHES FOR TURNING SCYTHE-SNATHS.

Specification forming part of Letters Patent No. 57,716, dated September 4, 1866.

To all whom it may concern:

Be it known that I, SPENCER HINTON, of Jackson, in the county of Jackson and State of Michigan, have invented a new and Improved Machine for Turning Scythe-Snaths and other Bent Sticks; and I do hereby declare that the following is a full, clear, and exact description thereof, which will enable those skilled in the art to make and use the same, reference being had to the accompanying drawings, forming part of this specification, in which—

Figure 1 is a perspective view. Fig. 2 is a back view of the plate G and the parts attached thereto, the plate H being removed. Fig. 3 is a side view of the portions shown in Fig. 2. Fig. 4 is a rear view of the plate H detached from the other portions. Figs. 5 and 6 are views of the two gages with the feed-knife and cutting-knife.

Similar letters of reference indicate corresponding parts.

The object of this invention is to obtain a machine for turning scythe-snaths and other bent sticks with facility and in a perfect manner.

R R, Figs. 1 and 2, is the foundation, to which are attached the two standards Q Q', provided at their upper ends, respectively, with bearings *o o*. The standard Q', with the bearing *o*, is cast with the foundation R R; but the standard Q is cast separately and bolted to the foundation, as shown at V.

G, Figs. 1 and 2, is one of a pair of circular plates, with hollow journals J and pulley P at one side, and grooves planed and the recess at the middle turned (for gage) at the opposite side. H, Fig. 4, is the other of the pair of plates, with hollow journals J' on one side, and grooves W planed and the recess at middle turned (for gage) into the opposite side. These plates are fastened in position by means of the bolts *y* and the pieces L. (See Fig. 5.) The pieces L (see Figs. 1, 2, and 3) are placed between the plates and diametrically opposite each other, the bolts *y* passing through the plates G H and pieces L.

The plates G H are separated by pieces L L far enough to allow the gage and knife holder and the gage and feed-knife holder to play freely to and from the center of machine be-

tween them, the ways W' on the gages fitting into the grooves W planed into the plates G H on the inside.

The gage and knife holders, as seen in Fig. 2, are pressed as near the center as the machine will allow, and are held in this position by the spiral springs S until, being put to work, the gages are forced apart by the stick. The springs, bearing between the back end of gage and the pieces L L, are held in position by the studs S', Figs. 3 and 4, which play freely through the holes *c* in the pieces L as the gages move toward and from the center of the machine.

The cutting-knife is seen in position at K, Fig. 6, and the feed-knife is seen in position at F, Fig. 1.

The machine is set in motion by means of a belt passed over the pulley P and attached to some power. The stick to be turned is introduced into the hollow journal J on the side of machine opposite pulley, between the gages B B. The feed-knife F, which is set into a spiral groove cut in the gage, operates to draw the stick into the machine, the cutting-knife K at the same time reducing the end of stick to the required size as it is forced through to the opposite side of gage or knife holder. The gage B, being set a trifle lower or nearer the center of machine than the knife K, and coming in contact with the turned surface, is raised or forced from the center and against the spiral springs S S. Consequently, as the knife continues to cut on a circle a trifle longer than that which the gage bears against, the stick is tapering from end to end. At the same time all the working parts being in one and the same vertical plane, or nearly so—namely, the feed-knife, cutting-knife, and gage—and the journals so near together and turned in the form of a bugle-mouth at the outer ends, allow a crooked stick to pass through as though it were straight, the portion of stick covered by working parts being to all intents and purposes straight.

Another mode of applying the gage is to place the knife a trifle lower or nearer the center of rotation than the side of gage next where the stick is introduced, thus leaving the gage to bear on the rough stick, the knife cutting enough below to clean the stick of all im-

perfections. At same time the shape of turn-out stick is as was the shape of rough stick, as regards its taper, yet turned round, as in the other case, the taper being governed by the taper of the general average of the prominent parts, and not by the general average of the whole stick.

The knife used for cutting has both its edges turned up, and is in the shape of a shallow gouge, so as not to leave marks from the corners.

It is necessary that the two persons (one on either side of the machine) holding the stick to be turned keep the part being worked upon in such a position as that the tangent to the curve at the point being worked will be at right angles to the plane of rotation of the working parts.

Having thus described my invention, I claim as new and desire to secure by Letters Patent—

1. The two plates G H, with hollow bugle-mouthed journals J J', respectively, on each, and a pulley, P, on one, G, fastened together

in such a position, with the pieces LL between them and diametrically opposite to each other, so that the journals J J' will be in line with each other and retain certain gage and knife holders between them, substantially as and for the purpose specified.

2. The two gage and knife holders B B, moving toward and from the center of rotation between the plates G H, substantially in the manner as and for the purpose set forth.

3. So fitting the ends of gages where the parts of the circle pass each other (when the gages are closed up, as in Fig. 1) into each other that as they open they will tend nearer to form a complete circle, and when fully open the circle will be complete, as shown in Figs. 3 and 4.

4. Attaching the knife and feed-knife to gage and knife holders, as herein described.

SPENCER HINTON.

Witnesses:

GEO. D. WALCOTT,

L. A. PENNOYER.