

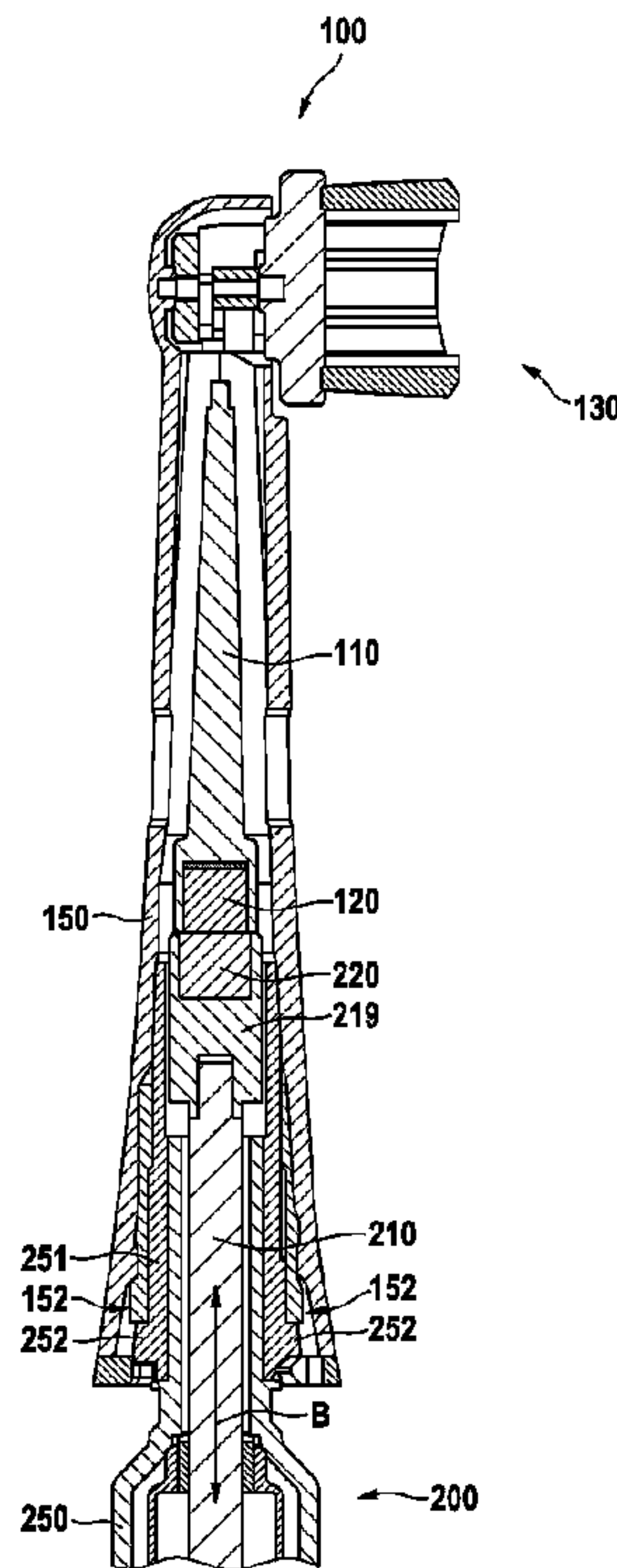

(86) Date de dépôt PCT/PCT Filing Date: 2012/07/25  
 (87) Date publication PCT/PCT Publication Date: 2013/01/31  
 (45) Date de délivrance/Issue Date: 2016/08/30  
 (85) Entrée phase nationale/National Entry: 2014/01/14  
 (86) N° demande PCT/PCT Application No.: IB 2012/053782  
 (87) N° publication PCT/PCT Publication No.: 2013/014617  
 (30) Priorité/Priority: 2011/07/25 (EP11006106.6)

(51) Cl.Int./Int.Cl. *A61C 17/34* (2006.01)  
 (72) Inventeurs/Inventors:  
 UTSCH, JOERN, DE;  
 SCHAEFER, NORBERT, DE  
 (73) Propriétaire/Owner:  
 BRAUN GMBH, DE  
 (74) Agent: TORYS LLP

(54) Titre : OUTIL DE NETTOYAGE BUCCO-DENTAIRE POUR UN DISPOSITIF D'HYGIENE BUCCO-DENTAIRE  
 (54) Title: ORAL CLEANING TOOL FOR AN ORAL HYGIENE DEVICE



(57) **Abrégé/Abstract:**

An attachment section (100), in particular a brush section, suitable for connection to a handle section (200) of an oral hygiene device is proposed. The attachment section has an attachment housing (150) having a first coupling structure (152) suitable for establishing a connection with a second coupling structure (252) of the handle section, at least a functional element (130) mounted at the attachment housing for driven movement, a motion transmitter (110) extending in a cavity formed inside of the attachment housing, the motion transmitter being functionally connected on one end with the functional element (130), and a first magnetic coupling element (120) arranged at another end of the motion transmitter, the first magnetic coupling element comprising at least a permanent magnet or a magnetizable element suitable for establishing a magnetic connection with a second magnetic coupling element provided in the handle section.

(12) INTERNATIONAL APPLICATION PUBLISHED UNDER THE PATENT COOPERATION TREATY (PCT)

(19) World Intellectual Property  
Organization  
International Bureau(10) International Publication Number  
**WO 2013/014617 A1**(43) International Publication Date  
31 January 2013 (31.01.2013)(51) International Patent Classification:  
*A61C 17/34* (2006.01)(21) International Application Number:  
PCT/IB2012/053782(22) International Filing Date:  
25 July 2012 (25.07.2012)

(25) Filing Language: English

(26) Publication Language: English

(30) Priority Data:  
11006106.6 25 July 2011 (25.07.2011) EP(71) Applicant (for all designated States except US): **BRAUN GMBH** [DE/DE]; Frankfurter Strasse 145, 61476 Kronberg-Taunus (DE).

(72) Inventors; and

(75) Inventors/Applicants (for US only): **UTSCH, Joern** [DE/DE]; Heinrich-Hoffmann-Strasse 2, 65760 Eschborn (DE). **SCHAEFER, Norbert** [DE/DE]; Hansaallee 134, 60320 Frankfurt/Main (DE).(74) Common Representative: **BRAUN GMBH**; c/o Timothy B. Guffey, The Procter & Gamble Company, Global Patent Services, 299 East Sixth Street, Sycamore Building, 4th Floor Cincinnati, Ohio 45202 (US).

(81) Designated States (unless otherwise indicated, for every kind of national protection available): AE, AG, AL, AM, AO, AT, AU, AZ, BA, BB, BG, BH, BN, BR, BW, BY, BZ, CA, CH, CL, CN, CO, CR, CU, CZ, DE, DK, DM, DO, DZ, EC, EE, EG, ES, FI, GB, GD, GE, GH, GM, GT, HN, HR, HU, ID, IL, IN, IS, JP, KE, KG, KM, KN, KP, KR, KZ, LA, LC, LK, LR, LS, LT, LU, LY, MA, MD, ME, MG, MK, MN, MW, MX, MY, MZ, NA, NG, NI, NO, NZ, OM, PE, PG, PH, PL, PT, QA, RO, RS, RU, RW, SC, SD, SE, SG, SK, SL, SM, ST, SV, SY, TH, TJ, TM, TN, TR, TT, TZ, UA, UG, US, UZ, VC, VN, ZA, ZM, ZW.

(84) Designated States (unless otherwise indicated, for every kind of regional protection available): ARIPO (BW, GH, GM, KE, LR, LS, MW, MZ, NA, RW, SD, SL, SZ, TZ, UG, ZM, ZW), Eurasian (AM, AZ, BY, KG, KZ, RU, TJ, TM), European (AL, AT, BE, BG, CH, CY, CZ, DE, DK,

[Continued on next page]

(54) Title: ORAL CLEANING TOOL FOR AN ORAL HYGIENE DEVICE

Fig. 5

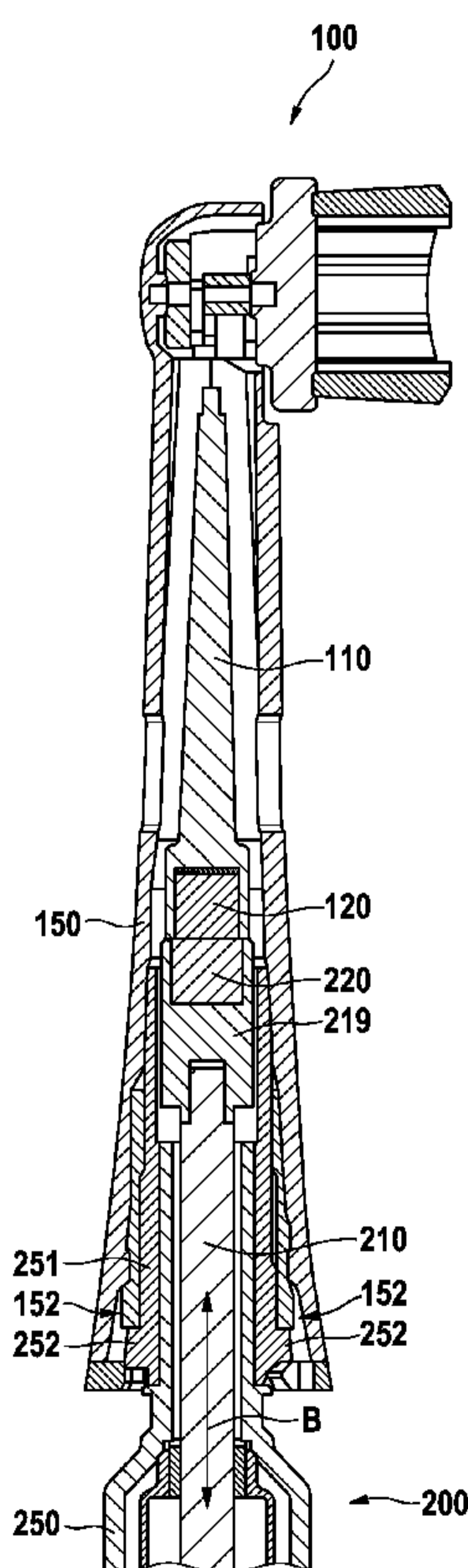

(57) Abstract: An attachment section (100), in particular a brush section, suitable for connection to a handle section (200) of an oral hygiene device is proposed. The attachment section has an attachment housing (150) having a first coupling structure (152) suitable for establishing a connection with a second coupling structure (252) of the handle section, at least a functional element (130) mounted at the attachment housing for driven movement, a motion transmitter (110) extending in a cavity formed inside of the attachment housing, the motion transmitter being functionally connected on one end with the functional element (130), and a first magnetic coupling element (120) arranged at another end of the motion transmitter, the first magnetic coupling element comprising at least a permanent magnet or a magnetizable element suitable for establishing a magnetic connection with a second magnetic coupling element provided in the handle section.

**WO 2013/014617 A1** 

---

EE, ES, FI, FR, GB, GR, HR, HU, IE, IS, IT, LT, LU,  
LV, MC, MK, MT, NL, NO, PL, PT, RO, RS, SE, SI, SK,  
SM, TR), OAPI (BF, BJ, CF, CG, CI, CM, GA, GN, GQ,  
GW, ML, MR, NE, SN, TD, TG).

— *before the expiration of the time limit for amending the  
claims and to be republished in the event of receipt of  
amendments (Rule 48.2(h))*

**Published:**

— *with international search report (Art. 21(3))*

## ORAL CLEANING TOOL FOR AN ORAL HYGIENE DEVICE

## FIELD OF THE INVENTION

The present invention is concerned with an attachment section for an oral hygiene device, a  
5 handle section for an oral hygiene device and an oral hygiene device.

## BACKGROUND OF THE INVENTION

It is known that electric oral hygiene devices, in particular electric toothbrushes, may have  
detachably mounted replacement attachments such as a replacement brush head of an electric  
10 toothbrush. It is further known that the coupling between the attachment and an handle of the oral  
hygiene device may be realized by mechanical means such as a snap hook provided at the  
attachment that snaps into a groove provided at the handle. Mechanical couplings often have a  
certain clearing or gap between the coupling partners due to tolerances between the coupling  
partners. Such clearings or gaps have the tendency to generate unwanted rattling noise during  
15 operation of the device.

It is therefore a desire to provide an improved coupling between an attachment section of an oral  
cleaning tool and a handle section of an oral hygiene device and in particular an attachment  
section of an oral cleaning tool and a handle section that enable such improved coupling.  
20

## SUMMARY OF THE INVENTION

In some embodiments, there is provided an attachment section, in particular a brush section,  
suitable for connection to a handle section of an oral hygiene device, which attachment section  
has an attachment housing having a first coupling structure suitable for establishing a connection  
25 with a second coupling structure of the handle section, at least a functional element mounted at  
the attachment housing for driven movement, a motion transmitter extending in a cavity formed  
inside of the attachment housing, the motion transmitter being functionally connected on one end  
with the functional element, and a first magnetic coupling element arranged at another end of the  
motion transmitter, the first magnetic coupling element comprising at least a permanent magnet  
30 or a magnetizable element suitable for establishing a magnetic connection with a second  
magnetic coupling element provided in the handle section.

In some embodiments, there is provided a handle section of an oral hygiene device for  
connection, optionally detachable connection, with an attachment section that has a second

2

magnetic coupling element arranged at a drive shaft arranged for establishing a magnetic connection with a first magnetic coupling element provided in the attachment section in an attached state and a second coupling structure for establishing a further connection with a first coupling structure provided at the attachment section, wherein the second magnetic coupling  
 5 element comprises a permanent magnet that fits into a cylinder having a diameter of at least about 4.5 mm and a length of about at least 4.5 mm.

In some embodiments there is provided an attachment section, in particular a brush section, suitable for connection to a handle section of an oral hygiene device, having an attachment  
 10 housing having a first coupling structure suitable for establishing a connection with a second coupling structure of the handle section, a motion transmitter extending in a cavity formed inside of the attachment housing, the motion transmitter being non-detachably connected at one end with the attachment section, in particular with a functional element mounted at the attachment housing for driven movement, and a first magnetic coupling element being arranged at another  
 15 end of the motion transmitter, the first magnetic coupling element comprising at least a permanent magnet or a magnetizable element suitable for establishing a magnetic connection with a second magnetic coupling element provided in the handle section, wherein optionally the first magnetic coupling element is retracted from an end of the attachment housing intended for coupling with the handle section, in particular by a distance of at least about 5.0 mm.

20

Further, in some embodiments, there is provided an electric oral hygiene device that comprises at least an attachment section as proposed and a handle section.

#### BRIEF DESCRIPTION OF THE DRAWINGS

25 The attachment section and the handle section as proposed will be further elucidated by reference to example embodiments and to figures. In the figures

Fig. 1 is a perspective view onto an oral hygiene device in the form of an electric toothbrush;

30 Fig. 2 is a sideways longitudinal cross-sectional cut through an example attachment section;

Fig. 3 is a transverse longitudinal cross-sectional cut through the attachment section shown in Fig. 2;

Fig. 4 is a longitudinal cross sectional cut through an example handle section;

- Fig. 5 is a longitudinal cut through a top portion of an example oral hygiene device;
- Figs. 6A – 6D show four example configurations of first and second magnetic coupling elements;
- Fig. 7 show simulation results for the force between the coupling partners of the four configurations shown in Fig. 6A – 6D;
- 5 Fig. 8 is a cross sectional cut through a top portion of a drive shaft of an example handle section;
- Fig. 9 is a cross sectional cut through a top portion of a drive shaft of an example handle section;
- Fig. 10 is a cross sectional cut through a top portion of a drive shaft of a further example handle section;
- 10 Fig. 11 is a cross sectional cut through a lower portion of a motion transmitter of an example attachment section;
- Fig. 12A is a side view depiction of an example embodiment of an attachment section as proposed with the attachment housing being transparent;
- 15 Fig. 12B is a depiction of the embodiment of an attachment section as shown in Fig. 12A, but seen from the backside (the front side being the side where the functional element is mounted); and
- Fig. 12C is a longitudinal cut through the attachment section shown in Figs. 12A and 12B seen from the backside of the attachment section.

20

#### DETAILED DESCRIPTION OF THE INVENTION

One aspect of the present disclosure is concerned with a connection, in particular a detachable connection, between an attachment section and a handle section of an (in particular electric) oral hygiene device where at least one connection (in particular a connection established between

25 movably mounted parts that are driven during operation and are intended for transferring motion from a motor in the handle section to a functional element in the attachment section) between the attachment section and the handle section is realized as a magnetic coupling. Mechanical couplings in general have inherently tolerance-based clearances or gaps between the coupling partners so that the coupling partners may move relatively to each other when the respective

30 connection is established between parts being driven during operation. Such a mechanical connection is then prone to generate unwanted noise during operation. A magnetic coupling can inherently be designed with less clearance so that a magnetic coupling is likely to produce less noise.

In some embodiments, an attachment section as proposed comprises a first magnetic coupling element that has at least a permanent magnet or a magnetizable element. The first magnetic coupling is arranged for establishing a magnetic connection with a second magnetic coupling element provided in a handle section in an attached state.

5

In some embodiments, an attachment section may additionally comprise an attachment housing, a functional element mounted for driven motion at the attachment housing and a motion transmitter. The motion transmitter may on one end be coupled to the functional element to transfer motion to the functional element and on another end may be equipped with the first magnetic coupling element. The motion transmitter may in particular extend in a cavity formed inside of the attachment housing. In some embodiments, the functional element may be a working element such as a brush head for cleaning teeth. In some embodiments, the attachment housing may have a first coupling structure intended for establishing a further connection with a second coupling structure provided at the handle section.

15

On one hand, a magnetizable element (e.g. a magnetizable steel or iron element) can be realized relatively cheap, and an attachment section intended for disposal after some period of use may then be realized relative cheap. This is in particular interesting in cases where the costs of a permanent magnet would be in the same order as the costs of the whole attachment section. On the other hand, a permanent magnet in the attachment section together with a permanent magnet in the handle section can provide for a higher coupling strength than a permanent magnet and magnetizable element combination at the same construction volume.

20

In some embodiments, the first magnetic coupling element comprises a protective cover that protects the first magnetic coupling element from corrosion or abrasion. In such embodiments, the protective cover may be abrasion resistant to the extent that during a typical lifetime of the attachment section the protective cover stays intact. As an oral hygiene device is used in a wet environment and typically with abrasive and/or corrosive chemicals such as mouth rinses or toothpaste, a thin coating such as e.g. a 10 micrometer thick gold coating may be abraded within a rather short period. A protective cover made of an about 20  $\mu\text{m}$  thick or more, optionally about 30  $\mu\text{m}$  or more, further optionally 40  $\mu\text{m}$  or more, even further optionally about 50  $\mu\text{m}$  or more metal layer, ceramic layer, glass layer or abrasion-resistant plastic or resin layer can be used. In some embodiments, the protective cover may have a thickness of 60  $\mu\text{m}$  or more, 70  $\mu\text{m}$  or more, 80  $\mu\text{m}$  or more, 90  $\mu\text{m}$  or more, 100  $\mu\text{m}$  or more, 150  $\mu\text{m}$  or more or 200  $\mu\text{m}$  or more, and/or any

30

thickness within or including the values provided above or any ranges including or within the values provided above. In some embodiments, the protective cover is realized as an essentially cup-shaped element that may be mounted by gluing, press-fitting, crimping, shrink-fitting, stamping, welding, snapping or any combination thereof. The protective cover is, in some particular embodiment, realized as a plate or disk that may be glued to the magnetic coupling element. In some embodiments, a protective cover is used that is manufactured in a deep-drawing, punch-drawing or thermoforming process.

In general, the protective cover may be designed to be abrasion resistant for a temporary period which corresponds to a typical period of use of the attachment section. The typical period of use may be about three months with three a switch-on periods of two to four minutes per day, hence the operation use period may be around 540 minutes to around 1.080 minutes. However, the protective cover may be designed to be abrasion resistant for longer or for shorter periods of time. In particular, in some embodiments, a protective cover may be used that is abrasion resistant for much longer than 1.080 minutes, e.g. 2.000 minutes, 4.000 minutes, 10.000 minutes or even longer.

In some embodiments, the first magnetic coupling element is at least partly accommodated in a recess or cavity provided in the motion transmitter. In some embodiments, the motion transmitter may comprise a holder element in which the first magnetic coupling element is at least partly accommodated. In some embodiments, the motion transmitter may comprise a rod element, in particular a rod element made from metal such as stainless steel. Such a metal rod is likely to provide a stability not provided by a motion transmitter that is completely made of a plastic material. The rod element may in some embodiments be pivot mounted at the functional element, in particular at a mounting location that is offset from an axis around which the functional element will be driven during operation. Alternatively or additionally, the rod element may be pivot mounted at a holder element, e.g. a holder element as mentioned above that has a recess that at least partly accommodated the first magnetic coupling element. The pivot mounting of the rod element is likely to support relative movement between the rod element and the functional element or the holder element, respectively.

In some embodiments, the attachment section, the protective cover, the first magnetic coupling element and/or the motion transmitter has a centering structure that is intended for at least

supporting the centering of the first magnetic coupling element with the second magnetic coupling element during an attachment process.

In some embodiments, the first magnetic coupling element may have at least one indentation or a groove that is filled with plastic material, in particular with injection molded plastic material. E.g. the holder element mentioned above may be made in a plastic injection molding step with the first magnetic coupling element being an insert element. Then, a manufacturing step of e.g. snapping the first magnetic coupling element into a holder element can be discarded with and further, the injection molding step may lead to lower clearances or gaps between the first magnetic coupling element and the holder element then in case of a later mounting of these two parts.

In an embodiment, the attachment section is arranged such that the motion transmitter is mounted free of any return force elements that would influence the behavior of a resonant drive provided in the handle section with a further spring. As springs typically have tolerances, a spring in the attachment section that is intended for coupling with a drive shaft of a resonant drive in a handle section could contribute to the spring-mass system that determines the resonance frequency of the resonant drive. Additionally, a spring in the attachment section may also produce additional noise in operation due to the tolerance needed for mounting of the spring.

In some embodiments, a handle section for connection, optionally detachable connection with an attachment section as proposed above comprises a second magnetic coupling element arranged at a drive shaft, which second magnetic coupling element is arranged for establishing a magnetic connection with a first magnetic coupling element provided at the attachment section and a second coupling structure for establishing a connection, in particular a mechanical connection (e.g. a force-fit or form-fit connection) with a first coupling structure provided at the attachment section, in particular at the attachment housing. The second magnetic coupling element may comprise at least a permanent magnet or a magnetizable element.

In at least some embodiments, a handle section as proposed comprises a linear drive (i.e. a resonant drive providing a linear reciprocal movement or a DC motor having a gear for converting a rotational motion into a oscillatory linear motion) for driving the drive shaft into a linear oscillation in a longitudinal direction (generally parallel to a longitudinal axis of the drive shaft or coinciding with a longitudinal axis of the drive shaft). In some embodiments, the linear

drive may provide via the drive shaft a linear oscillatory motion amplitude in a range of between about  $\pm 0.1$  mm to about  $\pm 2.0$  mm, in particular in arrange of between about  $\pm 0.5$  mm to about  $\pm 1.5$  mm, optionally in a range of between about  $\pm 0.75$  mm to about  $\pm 1.25$  mm, further optionally in a range of between about  $\pm 0.9$  mm to about  $\pm 1.1$  mm and even further optionally a linear oscillatory motion amplitude of about  $\pm 1.0$  mm. In some embodiments, the attachment section comprises a gear assembly that converts the linear motion provided by the drive shaft and transferred to the motion transmitter into a oscillatory rotation having a maximum angular deflection in a range of between  $\pm 5$  degrees to  $\pm 40$  degrees, in particular in a range of between about  $\pm 10$  degrees to  $\pm 30$  degrees, optionally in a range of between about  $\pm 15$  degrees to about  $\pm 25$  degrees, and further optionally of about  $\pm 20$  degrees (where the angular deflection is measured in an unloaded state of the functional element).

The longitudinal axis as referred to in all embodiments generally extends along a longitudinal or lengthwise dimension of the drive shaft or is parallel to a longitudinal axis of the drive shaft or coincides with a longitudinal axis of the drive shaft. The drive shaft means the drive shaft of the motor or extensions of that.

In an embodiment, the second magnetic coupling element may have a protective cover that protects the second magnetic coupling element from corrosion. The protective cover may be abrasion resistant to the extent that during a typical lifetime of the handle section the protective cover stays intact. As an oral hygiene device is used in a wet environment and typically with abrasive and/or corrosive chemicals such as mouth rinses or toothpaste, a thin coating such as e.g. a 10 micrometer thick tin coating may be abraded within a rather short period. A protective cover made of an about 20  $\mu\text{m}$  thick or more, optionally about 30  $\mu\text{m}$  or more, further optionally 40  $\mu\text{m}$  or more, even further optionally about 50  $\mu\text{m}$  or more metal layer, ceramic layer, glass layer or abrasion-resistant plastic or resin layer may be better suitable. In some embodiments, the protective cover may have a thickness of 60  $\mu\text{m}$  or more, 70  $\mu\text{m}$  or more, 80  $\mu\text{m}$  or more, 90  $\mu\text{m}$  or more, 100  $\mu\text{m}$  or more, 150  $\mu\text{m}$  or more or 200  $\mu\text{m}$  or more and/or any and/or any thickness within or including the values provided above or any ranges including or within the values provided above. The protective cover may be realized as an essentially cup-shaped element that may be mounted by gluing, press-fitting, crimping, shrink-fitting, stamping, welding, snapping or any combination thereof. The protective cover is, in a particular embodiment, realized as a plate or disk that may be glued to the magnetic coupling element. The protective cover for the second

magnetic coupling may be configured similarly to the protective cover described heretofore with regard to the first magnetic coupling.

- In an embodiment, the second magnetic coupling element is at least partly accommodated in a recess provided in the drive shaft. In an embodiment, the handle section, the protective cover, the second magnetic coupling element and/or the drive shaft may have a centering structure that is intended for at least supporting the centering of the first magnetic coupling element with the second magnetic coupling element during an attachment process.
- 10 In some embodiments, an oral hygiene device may comprise at least an attachment section as proposed and that may further comprise a handle section having a second magnetic coupling element and a second coupling structure for establishing a connection with the first coupling structure provided at the attachment section. In some embodiments, an oral hygiene device may comprise at least an attachment section as proposed and further a handle section in accordance
- 15 with a handle section as proposed in a previous paragraph above. In some embodiments, the handle section comprises a drive having a drive shaft that is arranged to provide a linear oscillating motion during operation and the contact faces of the magnetic coupling elements are arranged essentially perpendicular to the linear movement direction.
- 20 In some embodiments, as will be explained in more detail further below, the magnetic coupling between the first and the second magnetic coupling elements is designed to at least partially decouple in case of a pull-off force imposed on the magnetic connection that is beyond a threshold force. Such an at least partial decoupling of the magnetic coupling partners is then likely to interrupt the motion transfer and to generate noise, which can be noticed by a user, who
- 25 is then informed about a too high load.

As an example, in case of the oral hygiene implement being an electric toothbrush and the attachment being a replaceable brush head having as a functional element a bristle carrier mounted for oscillatory rotation, a magnetic coupling between a motor in a handle section of the oral hygiene device and a motion transmitter in the attachment section should be in a coupled

30 state for typical pull-off forces that occur during operation (i.e. brushing of teeth in an example case). Typical pull-off forces that occur during brushing between the first and second magnetic coupling elements may in particular be generated due to friction between treatment elements (e.g. bristles) mounted on the carrier and hard or soft tissue in the oral cavity (e.g. the teeth or the

gums). This friction increases with the pressure force with which the functional element (e.g. brush head) is applied onto the hard or soft tissue (e.g. the teeth). Typical applied pressure force values may lay in a range of between about 1.5 Newton (N) and about 3.5 N (pressure forces below this range are typically either not used or do not lead to a proper treatment result and pressure values above this range may potentially lead to discomfort and even injuries), in particular in a range of between about 2 N and 3 N. For the above oscillatory rotating brush heads it has been found that the pull-off force that acts at the magnetic coupling may then be above 5 N and in particular above 6 N and further particularly in a range of between about 6.5 N to about 8.0 N. Higher pull-off forces may then be due to a too high pressure force applied by the user or due to bristles getting stuck in between teeth. In both cases, it may be reasonable that the magnetic coupling is arranged to decouple at a pull-off force above the maximally occurring and allowed pull-off force. Firstly, it may support to indicate to the user that a too high pressure force is applied as the decoupling may be noticeable to the user. Secondly, such decoupling is likely to reduce pain that may occur in case stuck bristles are pulled out of between the teeth when the magnetic coupling would withstand higher pull-off forces. In both cases it is likely that the decoupling leads to an improved protection of hard and soft tissue against abrasion and other kind of damage. Thus, a threshold force may be set to 5 N, 5.5 N, 6 N, 6.5 N, 7 N, 7.5 N, 8 N, 8.5 N, 9 N, 9.5 N, or 10 N, where in particular the threshold force may be set to a value of at least 6.5 N, optionally of at least 7 N, further optionally of at least 7.5 N and yet even further optionally of at least 8 N. As will be seen further below, the threshold force can in particular be set by designing the magnetic coupling accordingly, e.g. by choosing the dimensions of the first and second magnetic coupling elements, choosing the respective materials from which the first and second coupling elements are made, or choosing a gap between the first and second magnetic coupling elements.

25

While it is here proposed to design the magnetic coupling in a manner that the magnetic coupling decouples in case a pull-off force is applied above a threshold force, the above example was experimentally derived for bristle carriers mounted for driven oscillatory rotation at the attachment housing. While it is not excluded that other functional elements may result in the same threshold force, another threshold force value may be found as preferred based on experimental investigation with other functional elements or for another intended oral hygiene application, e.g. tongue cleaning or gum massaging.

30

In some embodiments, the attachment section has a first magnetic coupling element that comprises a magnetizable element, which may in particular be made from stainless steel so that a further protective cover could be discarded with, which magnetizable element fits into a cylinder of at least about 4.5 mm diameter and of at least about 4.5 mm length. Optionally, the diameter  
5 may be at least about 5.0 mm, further optionally at least about 5.5 mm. Optionally, the length may be at least about 5.5 mm, further optionally at least about 6.5 mm.

In some embodiments, the handle section has a second magnetic coupling element that comprises a permanent magnet, in particular made of NdFeB, which permanent magnet fits into a cylinder  
10 of at least about 4.5 mm diameter and of at least about 4.5 mm length. Optionally, the diameter may be at least about 5.0 mm, further optionally at least about 5.5 mm. Optionally, the length may be at least about 5.0 mm, further optionally at least about 5.5 mm.

In some embodiments, the motion transmitter is non-detachably connected with the attachment  
15 section, in particular with a functional element mounted for driven movement.

In the following, a detailed description of several example embodiments will be given. It is noted that all features described in the present disclosure, whether they are disclosed in the previous description of more general embodiments or in the following description of example  
20 embodiments, even though they may be described in the context of a particular embodiment, are of course meant to be disclosed as individual features that can be combined with all other disclosed features as long as this would not contradict the gist and scope of the present disclosure. In particular, all features disclosed for either one of the first or second magnetic coupling elements may also be applied to the other one.

25

Fig. 1 is a perspective depiction of an example embodiment of an oral hygiene device 1, here realized as an electric toothbrush. The oral hygiene device 1 comprises a handle section 200 and an attachment section 100. Here, the attachment section 100 is realized as a detachable brush section. The attachment section 100 has a functional element 130, here realized as a brush head,  
30 which functional element 130 is movably mounted at an attachment housing 150 such that the functional element 130 can be driven into an oscillatory rotation (as shown with double arrow 21) around a rotation axis R that may be perpendicular to the longitudinal axis L of the attachment section 100. Instead of being realized as an electric toothbrush, the oral hygiene device may be realized as an (electric) tongue scraper, an (electric) flossing device, an (electric)

interdental cleaner etc. The attachment section may then accordingly be realized as a tongue scraper section, a flossing section, an interdental cleaning section etc. The functional element may the accordingly be realized as a tongue scraper head, a flossing head, an interdental cleaning head etc.

5

Fig. 2 is a lateral cross sectional cut through the attachment section 100 taken along a longitudinal axis of the attachment section 100. The attachment section 100 comprises the attachment housing 150 and the functional element 130, which is movably attached to the attachment housing 150.

10

The functional element 130 may comprise a carrier element 131 on which a plurality of cleaning elements 133 may be mounted for cleaning and massaging parts of the oral cavity such as teeth and gums. The carrier element 131 may be mounted to the attachment housing 150 via a mounting axle 132 for driven oscillatory rotation around a rotation axis R that may be essentially perpendicular to the longitudinal axis (reference numeral L in Fig. 1) of the attachment section 100.

15

The attachment section 100 may further comprise a motion transmitter 110 disposed within a cavity 159 formed within the attachment housing 150. The motion transmitter 110 may be functionally connected with the functional element 130 as will be explained in more detail with reference to Fig. 3. Generally and applicable to all embodiments, "functionally connected" shall mean a connection that is not intended to be disconnected and that shall enable that motion transmitted via the motion transmitter is transferred to the functional element. The motion transmitter 110 is arranged for transmission of a linear oscillatory movement to the functional element 130, which linear oscillatory motion may be generally parallel to the longitudinal axis of the attachment section 100 (as indicated by double arrow A). Such a linear oscillatory motion may be provided by a drive shaft of a handle section when the attachment section 100 is in an attached state, as will be explained in more detail with reference to Fig. 5.

20

25

The motion transmitter 110 may comprise a recess 112 realized as a blind hole provided at a first end 110A that is proximal to the opening of the cavity 159, which opening at the end of the attachment section 100 (i.e. the first end 110A of the motion transmitter 110 is distal to the functional element 130). A first magnetic coupling element 120 is disposed in the recess 112. Generally and, as mentioned above for all the described features, applicable for all embodiments,

30

12

the first magnetic coupling element 120 may be realized as a permanent magnet or a magnetizable element such as a block of magnetizable iron or steel. Typically, austenitic steel is not magnetizable, while martensitic or ferritic steel typically is magnetizable. The first magnetic coupling element 120 has a coupling side 121 that is oriented towards the opening provided at the distal end of the attachment section 100. Generally and applicable to all embodiments, the coupling side 121 may be retracted from the opening at the end of the attachment housing intended for coupling with a handle section so that the magnetic connection is established at a longitudinal position inside of the attachment housing, in particular where this longitudinal location is retracted by a value lying in the range of between about 0.5 cm to about 5.0 cm, e.g. 1.0 cm, 1.5 cm, 2.0 cm, 2.5 cm, 3.0 cm, 3.5 cm, 4.0 cm, 4.5 cm or any other value lying in the mentioned range from the end of the attachment housing and the length of the attachment housing may be in the range of between about 3.0 cm to about 10.0 cm.

The first magnetic coupling element 120 may be secured to the motion transmitter 110 in any suitable manner. For example, the first magnetic coupling element 120 may be glued to the motion transmitter 110, it may be snapped into a recess, it may be secured by injection molding at least a part of the motion transmitter over it or it may be secured by other means as will be explained further below.

In some example embodiments, the first magnetic coupling element is realized as a magnetizable iron or steel element. In case the first magnetic coupling element is realized by a corrosive material such as iron or a NdFeB material (from which relatively strong permanent magnets can be made), at least the coupling side of the first magnetic coupling element may have a protective cover to protect the first magnetic coupling element from corrosion.

25

The protective cover may be realized as a coating, a top cover, a cap or a cup, as will be explained in more detail further below. Generally and applicable to all embodiments, any protective cover applied to a first or second magnetic coupling element may lead to a distance between the first and second magnetic coupling elements in the attached state and thus to a reduction in the effective coupling force between the first and second magnetic coupling elements, so that a cover thickness of about or less than 0.5 mm, optionally about or less than 0.4 mm, further optionally of about or less than 0.3 mm, even further optionally of about or less than 0.2 mm, and yet even further optionally of about or less than 0.1 mm per cover could be chosen. In other embodiments, the protective cover may comprise a thickness as described previously. In

13

the shown embodiment, the first magnetic coupling element 120 is glued into the recess. It may have an anti-corrosive coating applied to the coupling side 121 or a protective cover that may be glued over the coupling side 121. In the shown embodiment, it would be sufficient to secure a disc-shaped protective cover onto the coupling side 121 of the first magnetic coupling element 120 as the other sides of the first magnetic coupling element 120 are protected by the surrounding material of the motion transmitter 110.

Generally and applicable to all embodiments, the first magnetic coupling element 120 may be realized as a cylindrical element having its cylinder axis essentially oriented parallel to the longitudinal axis of the attachment section 100, where the diameter of the cylinder may be chosen to be about or larger than 2 mm, optionally about or larger than 3 mm, further optionally about or larger than 4 mm, even further optionally about or larger than 5 mm, and yet even further optionally about or larger than 6 mm, and/or any number or range including or within the values provided.

The cylinder element may have any suitable height. In example embodiments, the height may be chosen to be about or larger than 2 mm, optionally as about or larger than 3 mm, further optionally about or larger than 4 mm, even further optionally about or larger than 5 mm, and yet even further optionally about or larger than 6 mm, and/or any number or range including or within the values provided. In some example embodiments, the height of the first magnetic coupling element may be chosen as large as the diameter. In other embodiments, the second magnetic coupling element may be designed to have any suitable shape. In such a case, the smallest possible cylinder into which such a first magnetic coupling element fits may have a diameter and a height as stated above.

In some example embodiments, the first magnetic coupling 120 is realized as a permanent magnet. In a case in which the attachment section 100 is a disposable attachment section intended for detachable attachment to a handle section 200 of an oral hygiene device, material costs may be considered as one important aspect. Realizing the first magnetic coupling element 120 and the second magnetic coupling element as permanent magnets may lead to a relatively high coupling force, while realizing the first magnetic coupling element 120 as a magnetizable element such as an iron or steel element reduces the material costs of the attachment section 100.

The attachment section 100 as shown in Fig. 2 may further comprise an insert element 151 that is snapped into the attachment housing 150 thereby forming part of the attachment housing 150. The insert element 151 may be equipped with a first coupling structure 152 intended for establishing a further coupling (i.e. a coupling different to the magnetic coupling that will be established by the first magnetic coupling element 120) with a handle section of an oral hygiene device in an attached state. In the shown example embodiment, the first coupling structure 152 is realized by mechanical coupling means such as snap hooks or spring elements for clamping projections provided at the handle section. In other example embodiments, the first coupling structure 152 may be realized by a further magnetic coupling element. The longitudinal positions where the magnetic connection is established and where the further connection (e.g. mechanical connection) is established may be separated, in particular by a distance lying in a range of between about 0.5 cm to about 3.0 cm.

Fig. 3 is a transverse longitudinal cross-sectional cut through the example attachment section shown in Fig. 2, where the viewing direction is towards the cleaning elements. As can be seen from Fig. 3, the motion transmitter 110 is coupled to the functional element by a coupling pin 111 provided at a second end 110B of the motion transmitter 110. The coupling pin 111 establishes a coupling with a coupling section 134 provided at the carrier element 131 at a position that is eccentric with respect to the rotation axis defined by the mounting axle 132. When the motion transmitter 110 is driven into a linear oscillatory movement as indicated by double arrow A, then the carrier element 131 will be driven into an oscillatory rotation around the rotation axis. As will also be explained further below, in some embodiments, the motion transmitter 110 is not associated with any return force element such as a biasing spring that would bias the motion transmitter into a defined rest position whenever the motion transmitter is not being driven.

Fig. 4 shows a longitudinal cut through a schematic handle section 200. In the shown example embodiment, the handle section 200 comprises a drive shaft 210 that functions as a movable motor part of a resonant linear drive 260, which linear drive 260 is disposed within the handle housing 250. During operation, the linear drive 260 provides for a linear oscillatory movement of the drive shaft 210 as is indicated by double arrow B. In the shown example embodiment, the drive shaft 210 may be prolonged by an extender element 219 that thus forms a part of the drive shaft 210. The extender element 219 can provide an increase in diameter with respect to the diameter of the drive shaft 210. A recess 211 may be provided in the extender element 219 for

accommodating a second magnetic coupling element 220. Instead of being accommodated in the extender element 219, the second magnetic coupling element 220 may of course be directly secured at the drive shaft 210 or the drive shaft may be made at least at its tip portion from a permanent magnetic material, which tip would then form the second magnetic coupling element 220. The second magnetic coupling element 220 has a coupling side 221 intended for getting into contact with the respective coupling side 121 (shown in Figure 2) of the first magnetic coupling element 120 (shown in Figure 2) of the attachment section when being attached. The coupling side of the first magnetic coupling element and the coupling side of the second magnetic coupling element may be flat or may at least partly be negatives of each other.

10

Generally and applicable to all embodiments, the second magnetic coupling element 220 may be realized as a cylindrical element having its cylinder axis essentially oriented parallel to the longitudinal axis of the drive shaft, where the diameter of the cylinder may be chosen to be about or larger than 2 mm, optionally about or larger than 3 mm, further optionally about or larger than 4 mm, even further optionally about or larger than 5 mm, and yet even further optionally about or larger than 6 mm or any individual number within or any ranges including or within the values provided. Any suitable height of the cylinder element may be chosen. For example, the height may be chosen to be about or larger than 2 mm, optionally about or larger than 3 mm, further optionally about or larger than 4 mm, even further optionally about or larger than 5 mm, and yet even further optionally about or larger than 6 mm. In some example embodiments, the height may be chosen as large as the diameter. In other embodiments, the second magnetic coupling element may be designed to have any suitable shape. In such a case, the smallest possible cylinder into which such a second magnetic coupling element fits may have a diameter and a height as stated above.

25

Generally, the handle section comprises a handle housing at which a second coupling structure intended for establishing a connection with the first coupling structure provided at the attachment section is realized. In the shown example embodiment, the handle section 200 has a handle housing 250 comprising a top handle housing section 250A intended for coupling with the attachment section and a lower handle housing section 250B intended to be gripped by a user's hand. Here, the top handle housing 250A section comprises a top part 251 at which a second coupling structure 252 may be realized, The second coupling structure 252 can form a further connection, with the first coupling structure 152 (shown in figure 2) of the attachment section.

30

In some embodiments, the second coupling structure 252 and the first coupling structure may establish a coupling which is different than the connection established by the first magnetic coupling and the second magnetic coupling or the coupling may be similar. For example, the coupling established by the first coupling structure and the second coupling structure may  
5 comprise a mechanical lock, magnetic lock, the like, or combinations thereof. In some embodiments having a top housing section 250A and a lower housing section 250B, the top housing section 250A may be arranged for driven motion, e.g. the top housing section 250A may perform an oscillatory rotation around the longitudinal axis, a longitudinal linear vibration, and/or a linear reciprocation along a direction which is generally parallel to a longitudinal axis of  
10 the drive shaft during operation. In such embodiments, the attachment housing that is coupled to the top housing section 250A performs a first motion during operation, e.g. rotation around the longitudinal axis, longitudinal linear vibration, and/or the linear reciprocation while the motion transmitter may drive the functional element into a second motion. The first and second motions are described further with regard to Figure 5. In some embodiments, the top housing section  
15 250A is not driven and remains stationary with respect to the lower housing section 250B.

Fig. 5 shows a longitudinal cross sectional cut of an attachment section 100 and a top housing section of a handle section 200 in an attached state. It is shown that the first and second magnetic coupling elements 120 and 220 have established a magnetic connection that couples the drive  
20 shaft 210 of the handle section 200 with the motion transmitter 110 of the attachment section 100 such that during operation, a linear reciprocation of the drive shaft 210 as indicated by double arrow B will be transferred to the functional element 130 via the motion transmitter 110. In some embodiments, as the transmitted motion is a linear reciprocation, the magnetic coupling does not need to transmit a rotational movement so that flat coupling sides of the first and second  
25 magnetic coupling elements are suitable.

Further, the first and second coupling structures 152 and 252 have established a second connection between the attachment housing 150 and the handle housing 250 such that the attachment section 100 is fixed with respect to the handle housing 250. For those embodiments  
30 where the top housing section is driven in an oscillatory rotation around the longitudinal axis, a longitudinal linear vibration, and/or a linear reciprocation along a direction which is generally parallel to a longitudinal axis of the handle 200, the movement of the top housing section is transmitted to the attachment housing via the connection provided between the first and second coupling structures 152 and 252.

As had been said before, the motion transmitter 110 may be mounted free of any return force element. It is known to use a return force element for a motion transmitter provided in an attachment section in case a mechanical connection is to be established between motion transmitter and drive shaft, as then essentially the coupling force needs first to be overcome during the attachment process. Without a return force element, the motion transmitter would potentially be pushed away in the attachment process and the mechanical coupling may not become easily established. For the described magnetic coupling, the first and second magnetic coupling elements will attract each other when the attachment section is attached to the handle section and the motion transmitter will then be moved towards to drive shaft so that the magnetic coupling is established without the need to first overcome any resistance. In particular for a handle section comprising a resonant drive, where the resonant frequency is dependent on the spring-mass system including a return-force element such as a spring acting on the motion transmitter, tolerances in the spring would lead to variations in the resonance frequency of the resonant drive for different attachments. Besides this, discarding a return force element supports a cost efficient manufacture.

Generally and applicable to all embodiments, the first and second magnetic coupling elements 120 and 220 may each be realized as a permanent magnet or a permanent magnet arrangement or as a magnetizable element such as an iron or steel element or an arrangement of such elements. Any kind of permanent magnet material could be used, e.g. the high energy materials SmCo or NdFeB, either realized as sintered elements or plastic-bonded elements, or any hard ferrite could be utilized such as sintered strontium ferrite. Plastic-bonded permanent magnet elements tend to have a relatively low magnetic flux density when compared with e.g. sintered permanent magnets. Sintered NdFeB magnets have a relatively high magnetic flux density but are also relatively expensive and are prone to corrosion. Hard ferrite magnets are relatively inexpensive and as ceramic materials less prone to corrosion but have only a limited magnetic flux density. In case that one of the first or second magnetic coupling elements is realized as a magnetizable element, the other one of the first or second magnetic coupling elements is to be realized as a permanent magnet or permanent magnet arrangement. Permanent magnets are widely available e.g. from IBS Magnet, Berlin, Germany.

In some embodiments, at least one of the first or second magnetic coupling elements is made of or consists at least partially of NdFeB material, in particular of sintered NdFeB material. In some

of these embodiments, the second magnetic coupling element provided in the handle section is made of or consists at least partially of the sintered NdFeB material. The latter allows for realizing the first magnetic coupling element as a relatively cheap magnetizable element such as an iron or steel element or by an arrangement of such elements.

5

Corrosion-prone permanent magnets like sintered NdFeB magnets may typically be available from a supplier with a thin anti-corrosive coating such as a tin or nickel coating. Unfortunately, toothpaste may abrade these standard coatings rather quickly during operation. Hence, it may then be necessary to equip these permanent magnets with a low-abrasive and anti-corrosive cover to withstand the conditions during operation of an oral hygiene device. Various materials may be chosen for the cover such as low-abrasive plastic materials (e.g. for making a deep-drawn plastic cup), ceramics, metal foils, glass etc.

Some permanent magnet materials such as NdFeB have a low operating temperature such as 60 degrees Celsius, which operating temperature is also dependent on the particular dimensions of the permanent magnet. For such permanent magnets, an anti-corrosive protection may not be applied by a plastic injection process during which temperatures of 200 degrees Celsius and more may occur as then the permanent magnet may lose its magnetization. The protective cover may be applied by casting (e.g. of a resin), gluing (e.g. of a metal, ceramic, or glass disc), snapping, welding etc. as was already mentioned.

The magnetic coupling established by the first and second coupling elements should withstand a typical pull-off force applied at the functional element as was explained above so that the magnetic coupling is not separated when such a force is applied. In example embodiments, a typical pull-off force applied at the functional element may be up to 10 Newton, i.e. the magnetic coupling should withstand a pull-off force up to a threshold value of about 10 Newton, optionally of up to about 9 Newton, further optionally of up to about 8 Newton, even further optionally of up to about 7 Newton, yet further optionally of up to about 6 Newton, yet even further optionally of up to about 5 Newton, and even more optionally of up to about 4 Newton or any value within or including the values provided.

Figs. 6A to 6D show four different example configurations S1 to S4 of first and second magnetic coupling elements. Fig. 7 shows simulation results for the effective force that exists between the coupling partners in the coupled state where the results are shown for various values of a gap

between the first and second magnetic coupling element, which gap reflects a protective cover on one or both of the magnetic coupling elements.

Fig. 6A shows a first configuration S1 of a first magnetic coupling element 410A being a  
5 cylindrical NdFeB permanent magnet and a second magnetic coupling element 420A being a stainless steel cylinder. The diameter  $d_1$  of the NdFeB permanent magnet 410A was set to 5 mm in the simulations and the height  $h_1$  was set to 5 mm. The diameter  $d_2$  of the stainless steel element was set to 5 mm and its height  $h_2$  was set to 4.5 mm. An arrow 419A indicates the magnetization direction of the permanent magnet that was here set to be along the longitudinal  
10 cylinder axis. The total height of the magnetic coupling arrangement is thus 9.5 mm plus gap thickness.

Fig. 6B shows a second configuration S2, where the only difference to the first configuration S1 shown in Fig. 1 is the magnetization direction 419B of the first magnetic coupling element 410B  
15 that is chosen to be perpendicular to the longitudinal cylinder axis.

Fig. 6C shows a third configuration S3 of a first magnetic coupling element 410C and a second magnetic coupling element 420C. The second magnetic coupling element 420C is again assumed to be a stainless steel element, but here having a height of 3.5 mm. The first magnetic coupling  
20 element 410C consists of a NdFeB permanent magnet having a height of 5 mm and a diameter of 3.5 mm. The NdFeB permanent magnet is glued into a cup-shaped iron container that has an outer diameter of 5 mm and an inner diameter of 4 mm. The iron container consists of a hollow iron cylinder 4104C and a disc-shaped back iron 4103C. The disc-shaped back iron 4103C has a diameter of 5 mm and a height of 1.5 mm. Overall height of the magnetic coupling arrangement  
25 is thus again 9.5 mm plus gap thickness. The magnetization direction of the NdFeB permanent magnet 4101C is indicated by arrow 419C and is assumed to be along the longitudinal cylinder axis.

Fig. 6D shows a fourth configuration S4, where the second magnetic coupling element 420D is  
30 as in the third configuration S3 a stainless steel cylinder having a height of 3.5 mm and a diameter of 5 mm. The first magnetic coupling element 410D consists of a first and a second half-cylindrical NdFeB permanent magnet 4101D and 4102D that are oppositely magnetized in longitudinal direction as is indicated by the magnetization arrows 4191D and 4192D, respectively. The cylinder formed by the two half-cylindrical NdFeB permanent magnets has a

height of 5 mm and a diameter of 5 mm. On the backside, the two half-cylindrical NdFeB permanent magnets are concluded by a back iron 4103D having a disc-like shape, the disc having a height of 1.5 mm and a diameter of 5 mm. Overall height is again 9.5 mm plus gap thickness.

- 5 In the simulations that were performed it was assumed that the remanence of the NdFeB permanent magnet material is 1370 mTesla. The properties of stainless steel 1.4021 were calibrated against measurements.

Fig. 7 shows simulation results for the four configurations S1, S2, S3, and S4 described above  
10 with reference to Figs. 6A to 6D. The abscissa indicates the gap between the flat coupling sides of the first and second magnetic coupling elements in millimeters. Gap material was assumed to be air. The ordinate indicates the force between the first and second magnetic coupling elements in the coupled state in Newton. It can be seen that configuration S4 generally leads to the highest threshold force value of the pull-off force that the magnetic coupling can withstand, e.g. at 0.1  
15 mm gap configuration S4 leads to a threshold force value of about 7.3 Newton at which the first and second magnetic coupling elements would decouple. The other configurations lead to a coupling force of about 3.4 to 4.9 Newton at a gap of 0.1 mm.

Fig. 8 is a schematic cross sectional cut through the top portion of a drive shaft 510 with a second  
20 magnetic coupling element 520. In the embodiment shown, the second magnetic coupling element 520 is glued into a protection cover 525 having a generally cup-shaped form. The protection cover 525 has a on its top side, where a first magnetic coupling element 620 indicated by a dashed line would approach the second magnetic coupling element 520 during the attachment procedure, a centering structure 526 realized by a raised edge such that a depression  
25 527 is formed into which the first magnetic coupling element 620 fits. The raised edge 526 may be tapered towards the approaching first magnetic coupling element 620 to support the centering function. While the magnetic coupling as such already has a certain self-centering function, a centering structure supports the centering procedure and can avoid misalignments between the first and second magnetic coupling elements. As has been stated before, the first and second  
30 magnetic coupling elements could be interchanged with respect to the features described, e.g. Fig. 8 may show an example embodiment of a first magnetic coupling element.

Here, the protection cover is realized by a cup that fully accommodates the second magnetic coupling element 520 and that at least partly extends over the drive shaft 510. In such an

embodiment, the second magnetic coupling element 520 needs not additionally be secured to the drive shaft 510 as the glue layer 524 fixes the drive shaft 510 and the second magnetic coupling element 520. The thickness  $d_3$  of the glue layer 524 and of the protection cover 525 should be chosen as low as possible to avoid reduction of the possible coupling force (see Fig. 7). As a matter of fact, the coupling side 521 does not need to be glued to the protection cover as the side glue layer suffices to establish a fixed connection. The thickness  $d_3$  could be chosen to be about or lower than 0.2 mm, optionally to be about or lower than 0.15mm, further optionally to be about or lower than 0.1 mm and even further optionally to be about or lower than 0.05 mm or any number within and/or any range within or including the values provided. The material of the protective cover could be a plastic material, a ceramic, a glass, or a (in particular non-magnetizable) metal. In an effort to reduce the thickness of the glue layer 524 and the protective cover, embodiments, are contemplated where the glue layer exists only on the sides of the drive shaft 510 and the second magnetic coupling element 520 but not in between a coupling side 521 of the second magnetic coupling element 520 and a bottom face 531 of the protective cover.

15

A protective cover made of magnetizable material would in the example shown in Fig. 8 lead to a magnetic short circuit between magnetic north pole and magnetic south pole of the permanent magnet and the achievable force between the magnetic coupling elements would be reduced.

20

Fig. 9 is a schematic depiction of another embodiment showing the top portion of a drive shaft 510A that has a recess 511A that accommodates a second magnetic coupling element 520A.

25

Bend wall portions 512A fix the second magnetic coupling element in the recess 511A. Prior to introducing the second magnetic coupling element 520A into the recess 511A, the wall portions 512A may have been straight to allow insertion of the second magnetic coupling element 520A into the recess 511A. Then, the wall portions 512A may have been bent, e.g. using a forming stamp, such that the second magnetic coupling element 520A is fixed in the recess. A protective cover 525A may cover the remaining opening so that the second magnetic coupling element 520A is protected from corrosion. The protective cover 525A may be a resin or any suitable material as described heretofore. In case that the top portion of the drive shaft 510A is made of a (non-magnetizable) metal or low-abrasive other material that can be formed in the stamping process, the protective layer 525A is effectively protected from being abraded and thus does here not necessarily need to have high abrasion-resistance.

30

Fig. 10 is a schematic depiction of another embodiment showing of the top portion of a drive shaft 510B and of a first magnetic coupling element 620B. The drive shaft 510B has a recess 511B that accommodates a second magnetic coupling element 520B, which second magnetic coupling element 520B extends above the drive shaft 510B such that a step-like structure 526B is achieved. A protective cover 525B that may be realized as a deep drawn plastic cup may be glued with a glue layer 524B over the extending top of the second magnetic coupling element 520B and a top part of the drive shaft 510B. The first magnetic coupling element 620B may comprise a depression 626B that is adapted to the step-like structure 526B so that the step-like structure 526B and the depression 626B cooperate to support the centering of the first and second magnetic coupling elements 620B and 520B in the attachment process. Similar to the embodiment shown in Figure 8, the glue layer 524B may be absent between a coupling side 521B and a bottom face 531B of the protective cover 525B in an effort to reduce the gap width between the first magnetic coupling element and the second magnetic coupling element. For those embodiments where the first magnetic coupling comprise a protective cap / cover, similar arrangements may be provided.

Fig. 11 is a schematic depiction of the lower portion of a motion transmitter 610C in which a recess 611C is provided that accommodates a first magnetic coupling element 620C. The recess 611C may be equipped with snap noses 612C (here realized with a 90 degrees undercut on their backside) so that the first magnetic coupling element 620C that has respective depressions is (non-detachably) secured at the motion transmitter 610C by mechanical means, here realized as snap means. On their frontside (side which is closer to the handle than the backside), the snap noses 612C may be tapered such that the first magnetic coupling element 620C may be pushed into position (snapped) during manufacturing. The motion transmitter may be realized as a plastic part while the first magnetic coupling element 620B may be realized as a non-corrosive steel part.

In other embodiments, the protective cover realized as a cup similar to the shown embodiment could be secured at the drive shaft by e.g. crimping, shrink-fitting, welding, or snapping.

30

Figs. 12A, 12B, and 12C show various views of another example embodiment of an attachment section as proposed. Identical parts have the same reference numerals in these three views. Reference is made in the following to all three figures 12A, 12B, and 12C. Not all reference numerals are repeated in all figures.

An attachment section 700 has an attachment housing 750, a functional element 730 realized as a brush head mounted at the attachment housing 750 for driven oscillatory rotation around a rotation axis R1, which rotation axis R1 is essentially perpendicular to a longitudinal extension direction of the attachment section 700. The attachment section 700 further comprises a motion transmitter 710 that extends in a cavity 759 formed inside of the attachment housing 750.

The functional element 730 (here: brush head) has a carrier element 731 on which cleaning elements such as bristle tufts may be mounted. The carrier element 731 may comprise a coupling element 731A that in particular may be an integral part of the carrier element 731. The carrier element 731 may be mounted at the attachment housing 750 by means of a fixation element 738 so that it cannot be easily detached from the attachment housing 750.

The motion transmitter 710 may comprise a holder element 712 and a rod element 716. The holder element 712 may at least partly accommodate a first magnetic coupling element 720 in a recess 711 at a first end 710A of the motion transmitter 710. The rod element 716 may in particular be made from metal such as stainless steel and may optionally be made from a metal wire. A metal rod element may provide a higher rigidity and elasticity than a respective motion transmitter part made of plastic material. A motion transmitter may be made completely as a single integral part from plastic material due to the higher ductility of plastic compared to metal. The rod element 716 may have a first coupling part 716A that is pivot-mounted at the holder element 712 and a second coupling part 716B that is pivot mounted at a coupling section 739 provided at the coupling element 731A of the carrier element 731. At least one of the first or second coupling parts 716A, 716B of the rod element 716 may be a bent rod section that may extend into a bore or blind hole in the holder element 712 or the coupling element 731A, respectively. As can be particularly be seen in Fig. 12C, the first magnetic coupling element 720 may have at least an indentation or groove 729 that is filled with injection molded plastic 714, i.e. the first magnetic coupling element 720 may have been directly overmolded with the holder element 712. This direct overmolding step in the manufacturing leads to minimal gaps or clearances between the first magnetic coupling element 720 and the holder element 712. Generally and applicable to all embodiments, the first magnetic coupling element may be directly overmolded with at least a part of the motion transmitter and a depression present at the first magnetic coupling element may be filled with injection molded plastic material such that the first

magnetic coupling element is fixedly secured at this injection molded part of the motion transmitter.

The holder element 712 has protrusions 713 extending in the longitudinal extension direction at the edge of a contact surface 721 of the first magnetic coupling element 720, which protrusions may be tapered radially outwards such that these protrusions form a centering structure that at least supports the centering of the magnetic connection between the first magnetic coupling element 720 and a second magnetic coupling element at a handle section during the attachment of the attachment section 700. The centering functionality also performs in an attached state when the first and second magnetic coupling elements have decoupled due to a too high pull-off force and the high pull-off force has vanished so that the first and second magnetic coupling elements couple again due to the magnetic force acting between them. In particular in cases where one of the first and second magnetic coupling elements is a magnetizable element, a self centering force as between two permanent magnets is not present and an additional centering structure supports to center the two coupling partners and thus to optimize the coupling force.

In some embodiments, cleaning elements arranged on the attachment section may be made from a soft plastic material such as rubber or a thermoplastic elastomer (TPE) or may be made from more rigid plastic material such as polyamide (e.g. PA 6.12). Cleaning elements may have any kind of suitable height, which height may be chosen to lie between 0.2 mm (e.g. for tongue cleaner structures) and 30 mm, where a typical length of a cleaning element may lie in the range of between about 2.0 mm to about 15.0 mm, optionally between about 5.0 mm and 11.0 mm. Cleaning elements may have any suitable diameter, which diameter may be chosen to lie in a range of between about 0.2 mm to about 20 mm, optionally in a range of between about 0.5 mm to about 8.0 mm.

Additionally, it should be noted that the cleaning elements may comprise any suitable cleaning element and/or may comprise elements which are utilized for massaging gums, cleaning the tongue, providing chemistry to an area of the oral cavity, e.g. antimicrobial agents, malodor agents, flavor agents, anti-plaque agents, anti-gingivitis agents, whitening agents, or the like.

For example, in some embodiments, the cleaning elements may comprise tufts. The tufts may comprise a plurality of individual filaments which are securely attached to the head. Such filaments may be polymeric and may include, for example, polyamide or polyester. The

longitudinal and cross sectional dimensions of the filaments of the invention and the profile of the filament ends can vary. Additionally, the stiffness, resiliency and shape of the filament end can vary. Some examples of suitable dimensions include a length between about 3 mm to about 15 mm, or any individual number within the range. Additionally, the filaments may include a substantially uniform cross-sectional dimension of between about 100 to about 350 microns, or any individual number within the range. The tips of the filaments may be any suitable shape, examples of which include a smooth tip, a rounded tip, tapered tip, a pointed tip. In some embodiments, the filaments may include a dye which indicates wear of the filaments as described in U.S. Patent No. 4,802,255. Some examples of suitable filaments for use with the brush are described in U.S. Patent No. 6,199,242. Other suitable examples of bristles include textured bristles, e.g., single and multicomponent bristles (e.g., bristles formed by coextruding different polymers), crimped bristles, gum massaging bristles, bristles of varying configurations (e.g., bristles having multiple lumens), and/or combinations thereof.

Other suitable examples of cleaning elements include those described in U.S. Patent Application Publication Numbers 2002/0059685; 2005/0000043; 2004/0177462; 2005/0060822; 2004/0154112; U.S. Patent Nos. 6,151,745; 6,058,541; 6,041,467; 6,553,604; 6,564,416; 6,826,797; 6,993,804; 6,453,497; 6,993,804; 6,041,467; and U.S. Patent Application Serial Nos. 12/008,073, filed on January 8, 2008, entitled, "TOOTHBRUSHES" and 60/928,012, filed on May 7, 2007, entitled "ORAL HYGIENE IMPLEMENTS".

Additionally, any suitable arrangement of cleaning elements may be utilized. Some suitable examples include those described in U.S. Patent Nos. 5,836,769; 6,564,416; 6,308,367; 6,108,851; 6,058,541; and 5,396,678.

In addition to bristles and/or bristle tufts, the cleaning elements may also include elastomeric structures, foams, combinations thereof, and the like. For example, the cleaning elements may comprise elastomeric fins as described in U.S. Patent No. 6,553,604 and U.S. Patent Application Publication No. 2007/0251040A1. As yet another example, the cleaning elements may comprise elastomeric cup shaped elements as described in U.S. Patent Publication No. 2004/0154112A1. In some embodiments, the cleaning elements may comprise a combination of elastomeric elements and bristles. As an example, a combination of fins and bristles may be utilized, a combination of an elastomeric cup(s) and bristles may be utilized, and/or combinations of elastomeric elements either alone or in combination with bristles may be utilized. Combinations of elastomeric cleaning elements are described in U.S. Patent Publication No. 2009/0007357A1.

The cleaning elements and/or massaging elements may be attached to the head in any suitable manner. Conventional methods include stapling, anchor free tufting, and injection mold tufting. For those cleaning elements that comprise an elastomer, these elements may be formed integral  
5 with one another, e.g. having an integral base portion and extending outward therefrom or discretely. The elastomer elements may be injection molded in the head.

In addition to the cleaning elements described heretofore, the head may comprise a soft tissue cleanser constructed of any suitable material. Some examples of suitable material include  
10 elastomeric materials; polypropylene, polyethylene, etc; the like, and/or combinations thereof. The soft tissue cleanser may comprise any suitable soft tissue cleansing elements. Some examples of such elements as well as configurations of soft tissues cleansers on a toothbrush are described in U.S. Patent Application Nos. 2006/0010628; 2005/0166344; 2005/0210612; 2006/0195995; 2008/0189888; 2006/0052806; 2004/0255416; 2005/0000049; 2005/0038461;  
15 2004/0134007; 2006/0026784; 20070049956; 2008/0244849; 2005/0000043; 2007/140959; and U.S. Patent Nos. 5,980,542; 6,402,768; and 6,102,923.

Additionally, for those embodiments comprise elastomer elements on a first side of the head and a second side of the head, the second side being opposite the first side, the elastomer elements of  
20 both sides of the head may be unitarily formed. For example, the head sans the elastomeric elements may comprise openings therethrough which can allow elastomeric material to flow from the first side of the head to the second side of the head.

Materials for manufacturing at least a part such as the housing of the handle section or the  
25 housing of the attachment section may be any suitable plastic or non-plastic material, where typical plastic materials may comprise at least one from the group consisting of polypropylene (PP), thermoplastic elastomer (TPE), polyoxymethylene (POM), a blend of polyester and polycarbonate such as Xylex available from SABIC, Saudi Arabia, acrylonitrile styrene acrylateor (ASA), polybutylene terephthalate (PBT). Instead of plastic, metal, glass, or wood  
30 may also be chosen as material for making at least a part of the attachment section.

The dimensions and values disclosed herein are not to be understood as being strictly limited to the exact numerical values recited. Instead, unless otherwise specified, each such dimension is

WO 2013/014617

PCT/IB2012/053782

27

intended to mean both the recited value and a functionally equivalent range surrounding that value. For example, a dimension disclosed as "40 mm" is intended to mean "about 40 mm."

5

The citation of any document is not an admission that it is prior art with respect to any invention disclosed or claimed herein or that it alone, or in any combination with any other reference or references, teaches, suggests or discloses any such invention. Further, to the extent that any meaning or definition of a term in this document conflicts with any meaning or  
10 definition of the same term in a document referenced, the meaning or definition assigned to that term in this document shall govern.

The scope of the claims should not be limited by the preferred embodiments set forth in the examples, but should be given the broadest interpretation consistent with the  
15 description as a whole. It is therefore intended to cover in the appended claims all such changes and modifications that are within the scope of this invention.

## CLAIMS

What is claimed is:

1. An oral cleaning tool for an electric oral hygiene device, comprising:

a housing having a head section with a head cavity for accommodating a movable brush head or an oral cleaning head and a neck section with a neck cavity and a handle coupling section;

a first magnetic coupling element including at least a permanent magnet or a magnetizable element being provided in the neck section for mechanical handle drive shaft connection by magnetic interaction;

wherein the first magnetic coupling element is mounted at a motion transmitter, the motion transmitter extending inside the neck cavity to the head cavity, the motion transmitter arranged so as to be movable in a linear or longitudinal direction, and wherein the motion transmitter is coupled with the brush head or oral cleaning head, the brush head or oral cleaning head arranged so as to oscillate in a rotational direction.

2. The oral cleaning tool according to claim 1, wherein the oral cleaning tool is a brush section.
3. The oral cleaning tool according to claim 1 or 2, wherein the first magnetic coupling element, the motion transmitter, and the brush head or oral cleaning head are arranged and coupled so as to be drivable with an operation frequency of from about 140 to about 180 Hz.
4. The oral cleaning tool according to claim 3, wherein the operation frequency is between 150 and 170 Hz.
5. The oral cleaning tool according to any one of claims 1 to 4, wherein the first magnetic coupling element is a two component part including a metal and/or a ferrous composition that is mounted or in-molded in a plastic element.

6. The oral cleaning tool according to any one of claims 1 to 5, wherein the first magnetic coupling element has a protective cover that covers at least a coupling side of the first magnetic coupling element that is arranged for establishing a magnetic connection.
7. The oral cleaning tool according to claim 6, wherein the protective cover is a cup-shaped element or an anti-corrosive, abrasion-resistant coating.
8. The oral cleaning tool according to claim 6 or 7, wherein the protective cover is a cup that is mounted by gluing, press-fitting, crimping, shrink-fitting, welding, or snapping or any combination thereof.
9. The oral cleaning tool according to any one of claims 6 to 8, wherein the protective cover has a thickness of less than about 0.2 mm at the coupling side of the first magnetic coupling element.
10. The oral cleaning tool according to any one of claims 6 to 9, wherein the protective cover has a thickness of less than about 0.1 mm at the coupling side of the first magnetic coupling element.
11. The oral cleaning tool according to any one of claims 1 to 5, wherein the first magnetic coupling element is provided with a uncovered or blank surface of a coupling side of the first magnetic coupling element that is arranged for establishing a magnetic connection.
12. The oral cleaning tool according to any one of claims 1 to 11, wherein the motion transmitter is a rod element or is mounted free of any return springs.
13. The oral cleaning tool according to claim 12, wherein the rod element is pivotable mounted with either the movable brush head or oral cleaning head or with the first magnetic coupling element.
14. The oral cleaning tool according to any one of claims 1 to 13, wherein the first magnetic coupling element and/or the motion transmitter or rod element are provided contact free and

spaced in the neck cavity relative to an inner housing wall of the neck, so that the first magnetic coupling element is able to laterally align with its coupling partner of a handle.

15. The oral cleaning tool according to any one of claims 1 to 14, further comprising a centering structure with either a tapered protruding side wall or a tapered recessed side wall for mechanical connection of the housing independent from the mechanical connection provided by the first magnetic coupling element.

16. An oral cleaning tool for an electric oral hygiene device, comprising:

a housing having a head section with a head cavity for accommodating a movable oral cleaning head and a neck section with a neck cavity and a handle coupling section;

a first magnetic coupling element including at least a permanent magnet or a magnetizable element being provided in the neck section for mechanical handle drive shaft connection by magnetic interaction;

wherein the first magnetic coupling element is mounted at a motion transmitter, the motion transmitter extending inside the neck cavity to the head cavity, the motion transmitter arranged so as to be movable in a linear or longitudinal direction, and wherein the motion transmitter is coupled with the oral cleaning head, such that during operation, the linear reciprocation is transmitted to the oral cleaning head,

and wherein the first magnetic coupling element has a protective cover that covers at least a coupling side of the first magnetic coupling element that is arranged for establishing a magnetic connection and wherein the protective cover is a cup that is mounted by gluing, press-fitting, crimping, shrink-fitting, welding, or snapping or any combination thereof.

17. The oral cleaning tool according to claim 16, wherein the first magnetic coupling element, the motion transmitter and the oral cleaning head are arranged and coupled so as to be drivable with an operation frequency of from about 140 to about 180 Hz.

18. The oral cleaning tool according to claim 16, wherein the first magnetic coupling element is a two component part including a metal and/or a ferrous composition that is mounted or in-molded in a plastic element.
19. The oral cleaning tool according to claim 16, wherein the protective cover has a thickness of less than about 0.2mm at the coupling side of the first magnetic coupling element.
20. The oral cleaning tool according to claim 16, wherein the first magnetic coupling element is provided with an uncovered or blank surface of a coupling side of the first magnetic coupling element that is arranged for establishing a magnetic connection.
21. The oral cleaning tool according to claim 16, wherein the motion transmitter is a rod element.
22. The oral cleaning tool according to claim 21, wherein the rod element is pivotably mounted with either the movable oral cleaning head or with the first magnetic coupling element.
23. The oral cleaning tool according to claim 21, wherein the first magnetic coupling element and/or the rod element are spaced in the neck cavity relative to an inner housing wall of the neck, so that the first magnetic coupling element is able to laterally align with its coupling partner of a handle.
24. The oral cleaning tool according to claim 16, further comprising a centering structure with either a tapered protruding side wall or a tapered recessed side wall for mechanical connection of the housing independent from the mechanical connection provided by the first magnetic coupling element.

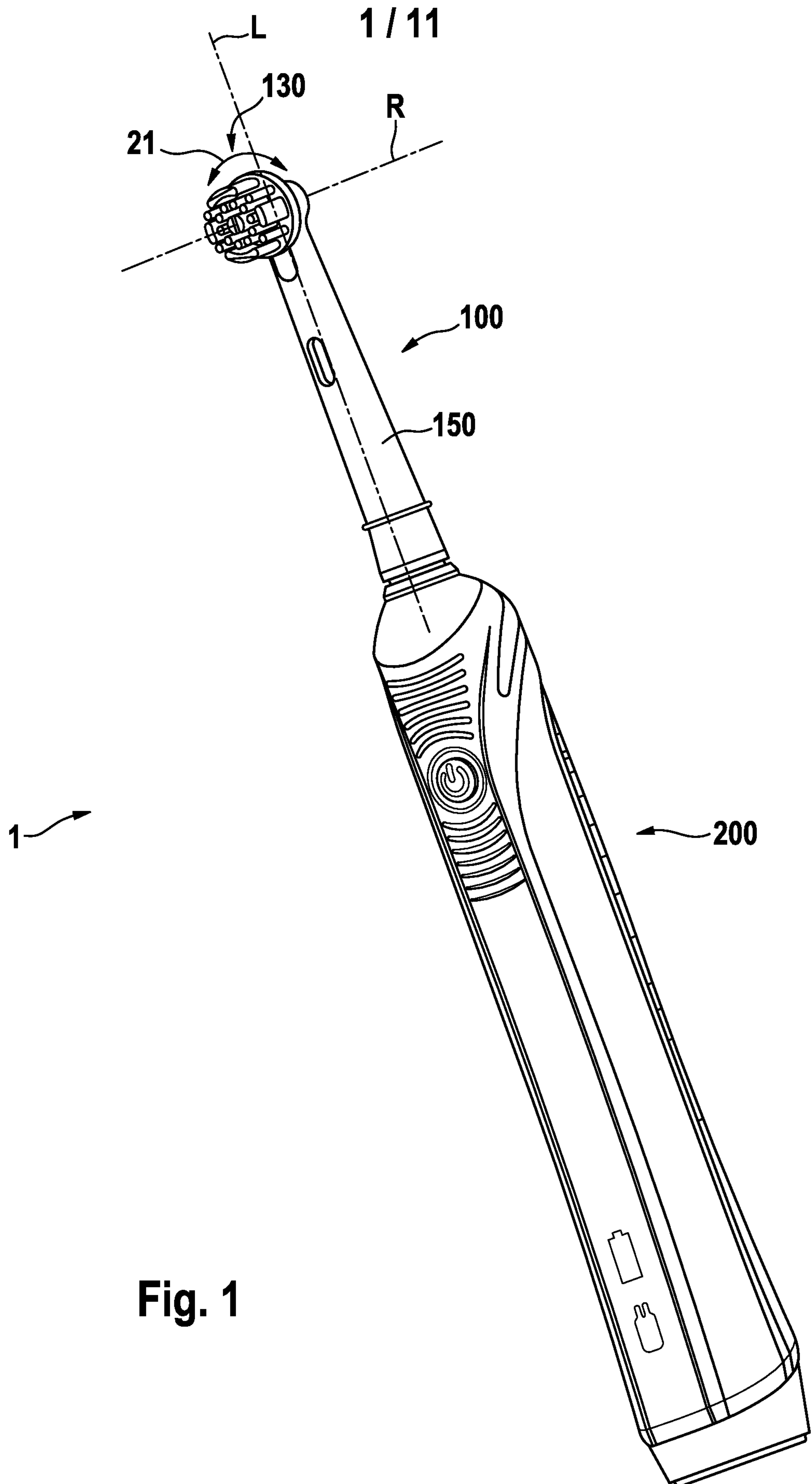

**Fig. 1**

2 / 11

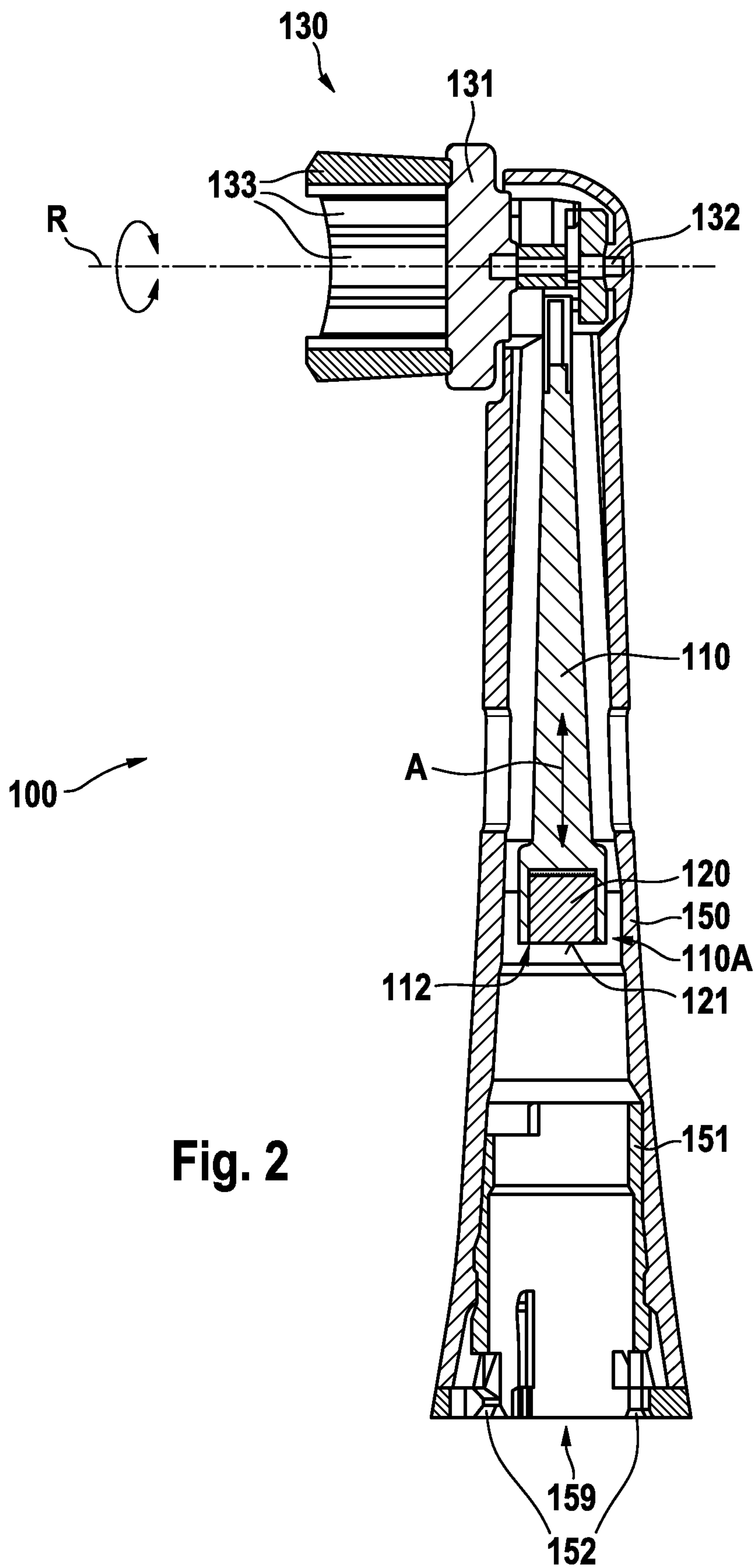
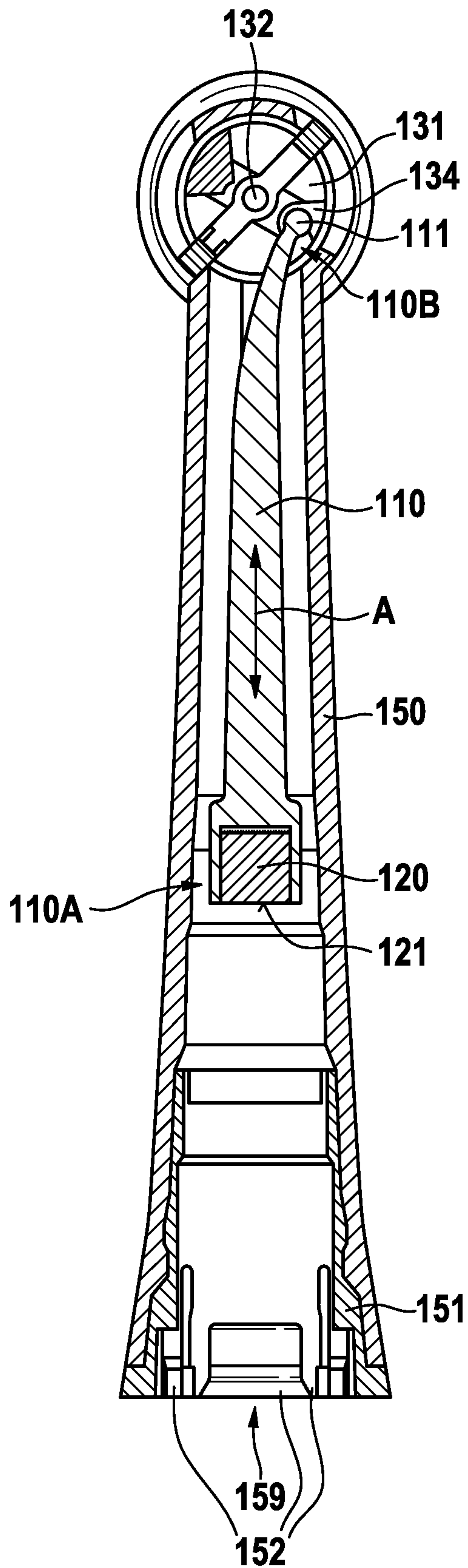

Fig. 2

3 / 11

Fig. 3



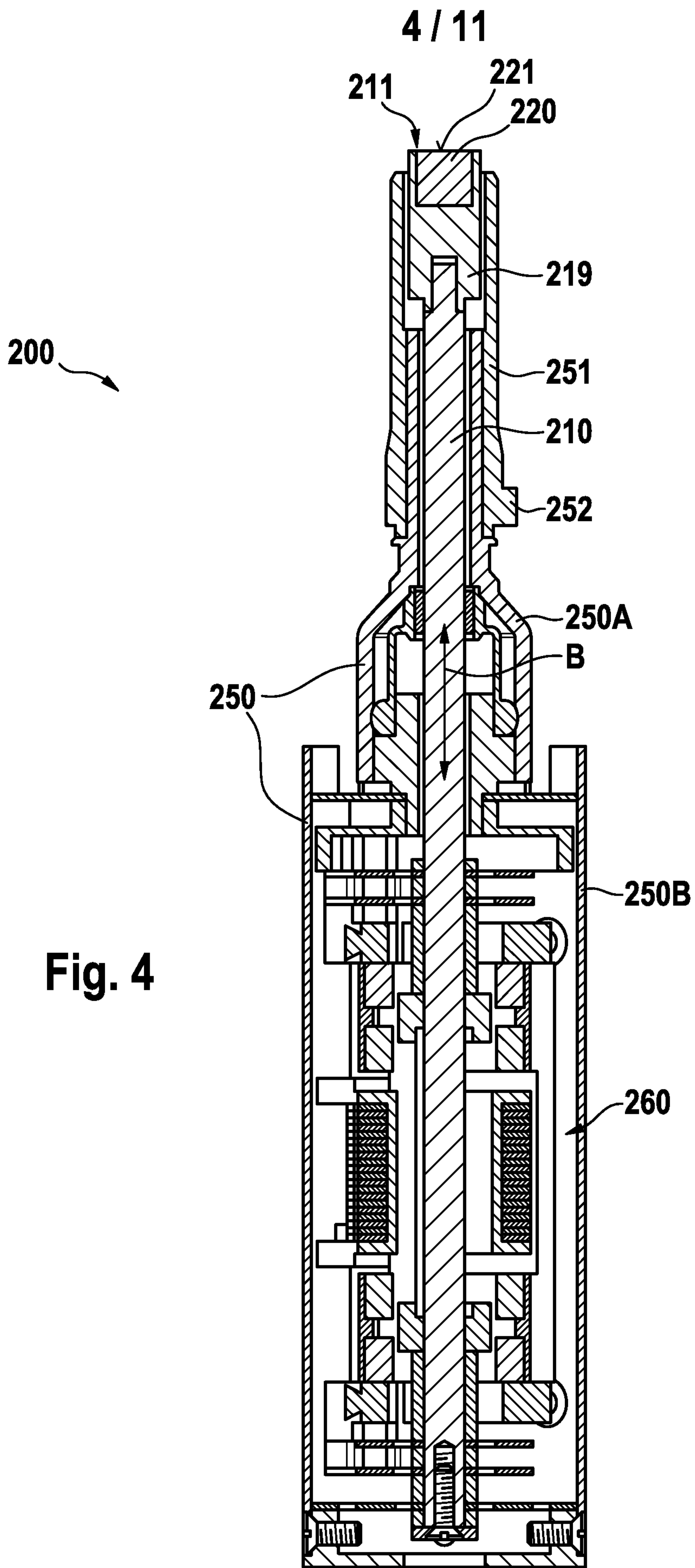
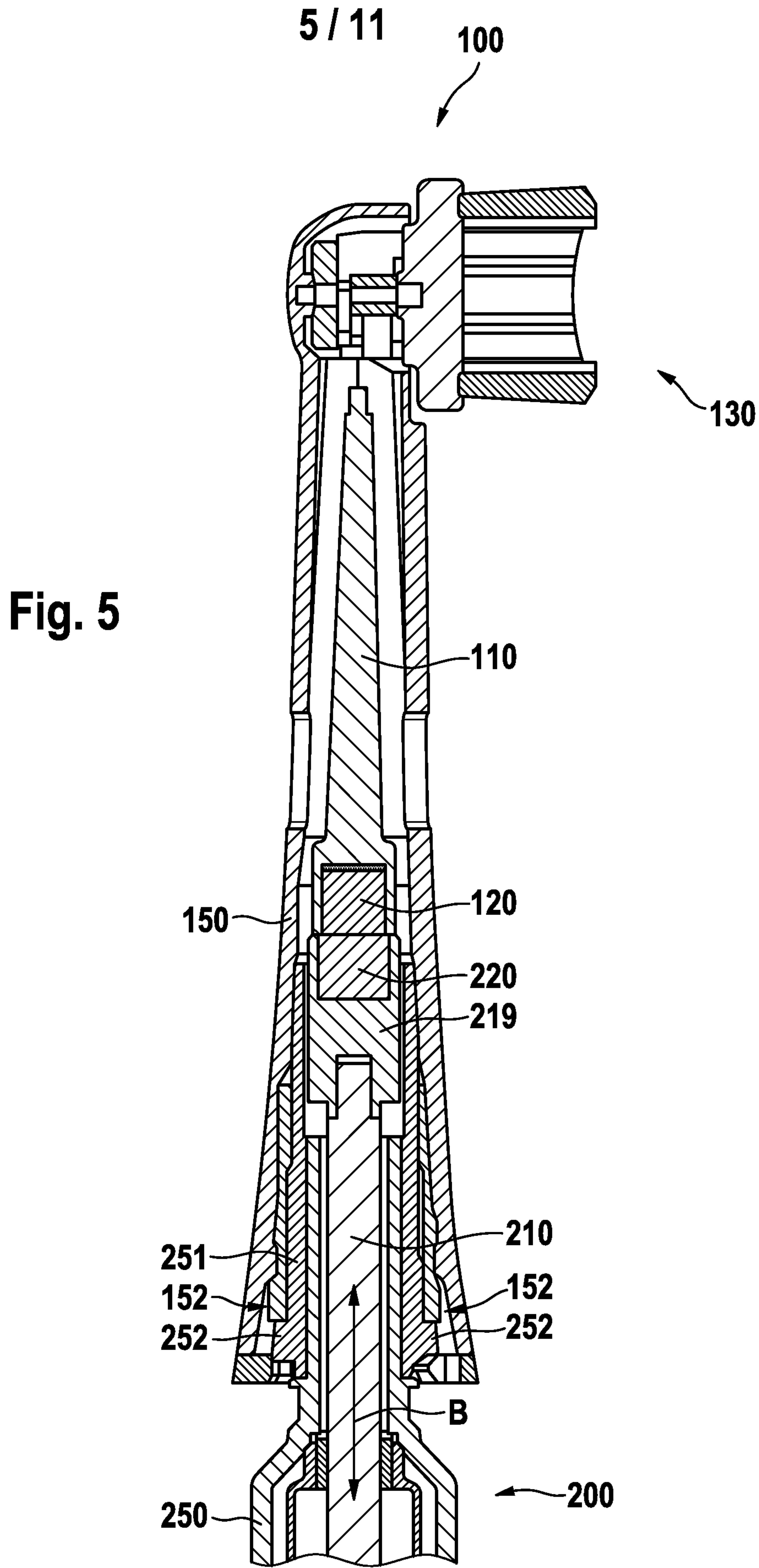

Fig. 4



6 / 11

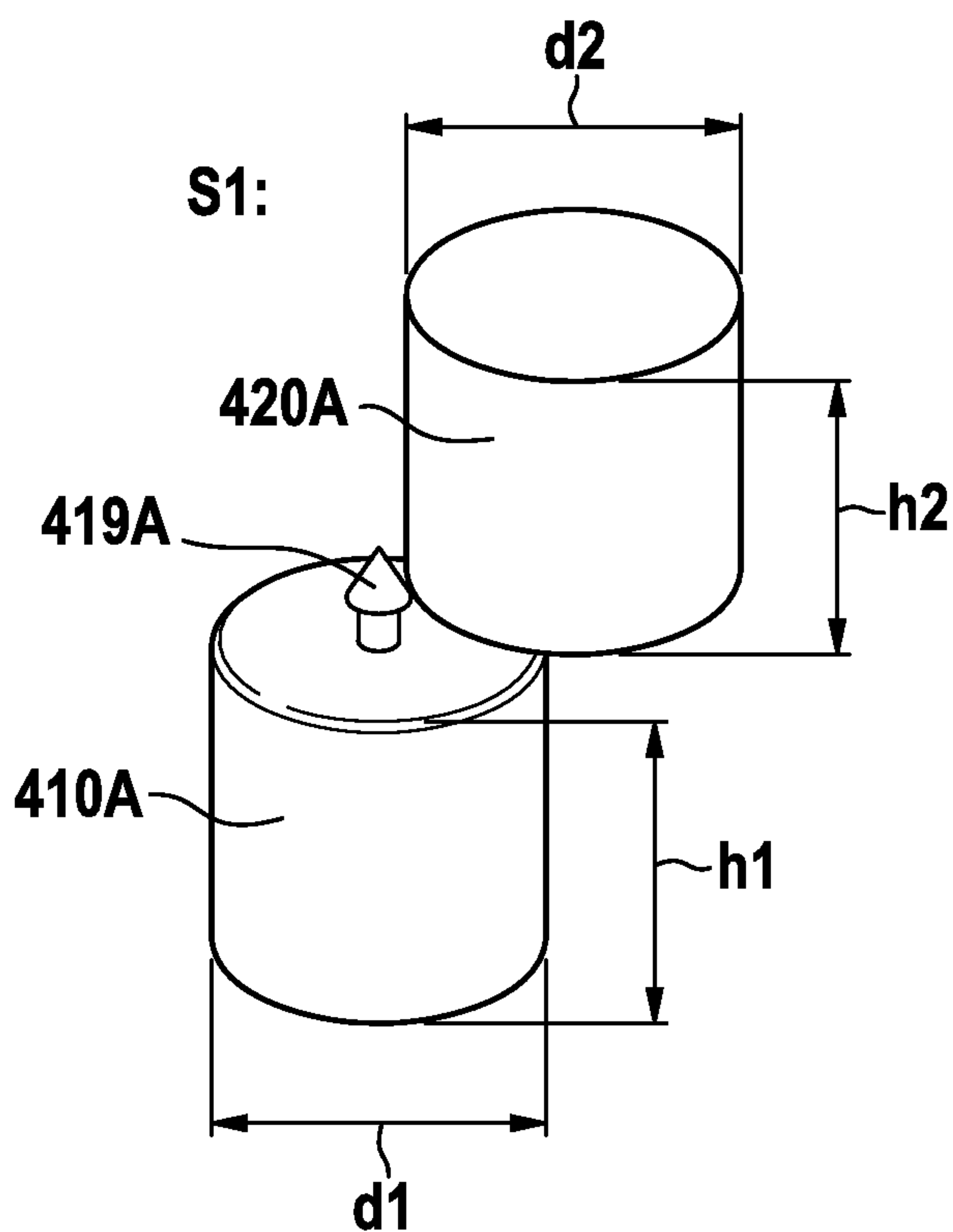

Fig. 6A

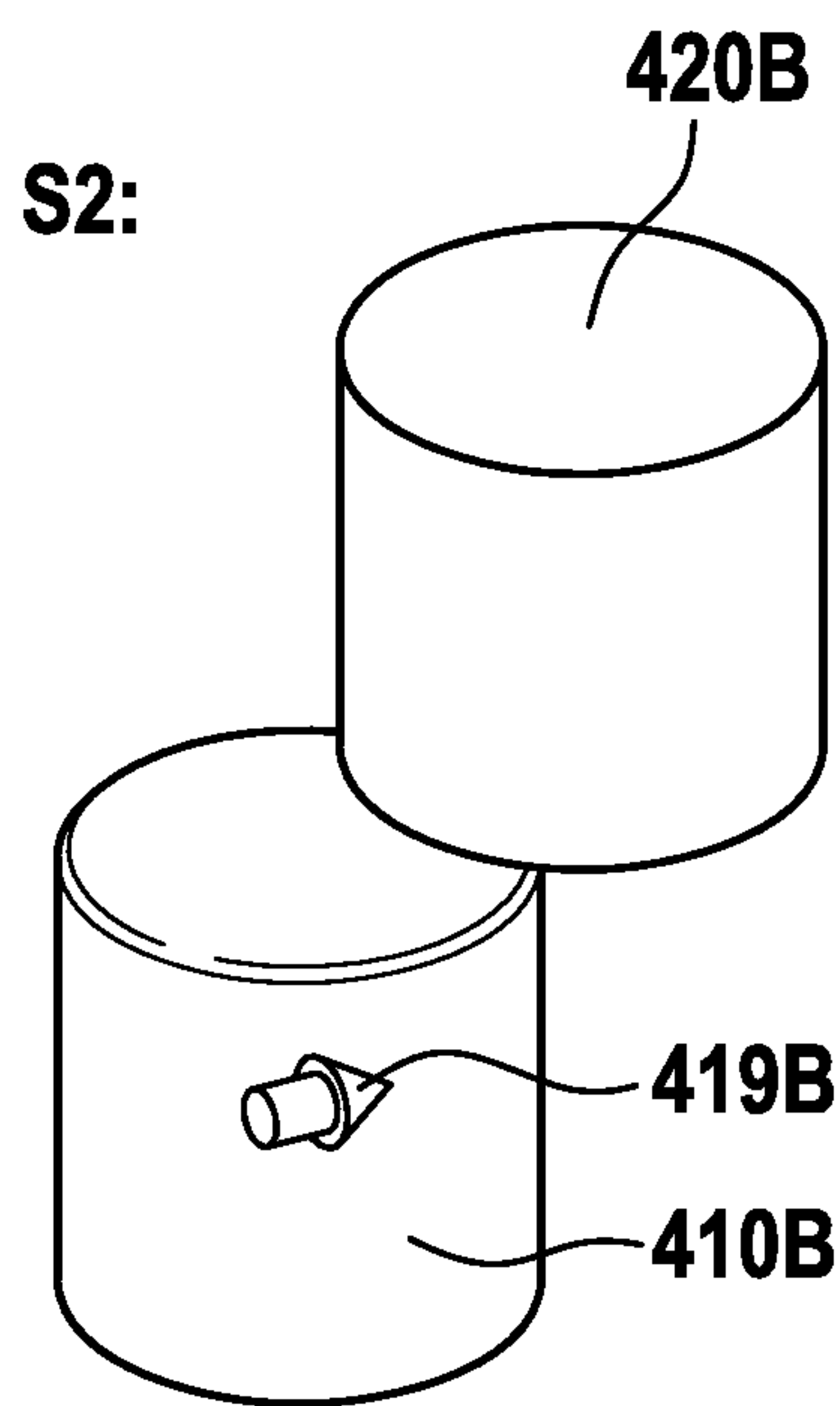

Fig. 6B

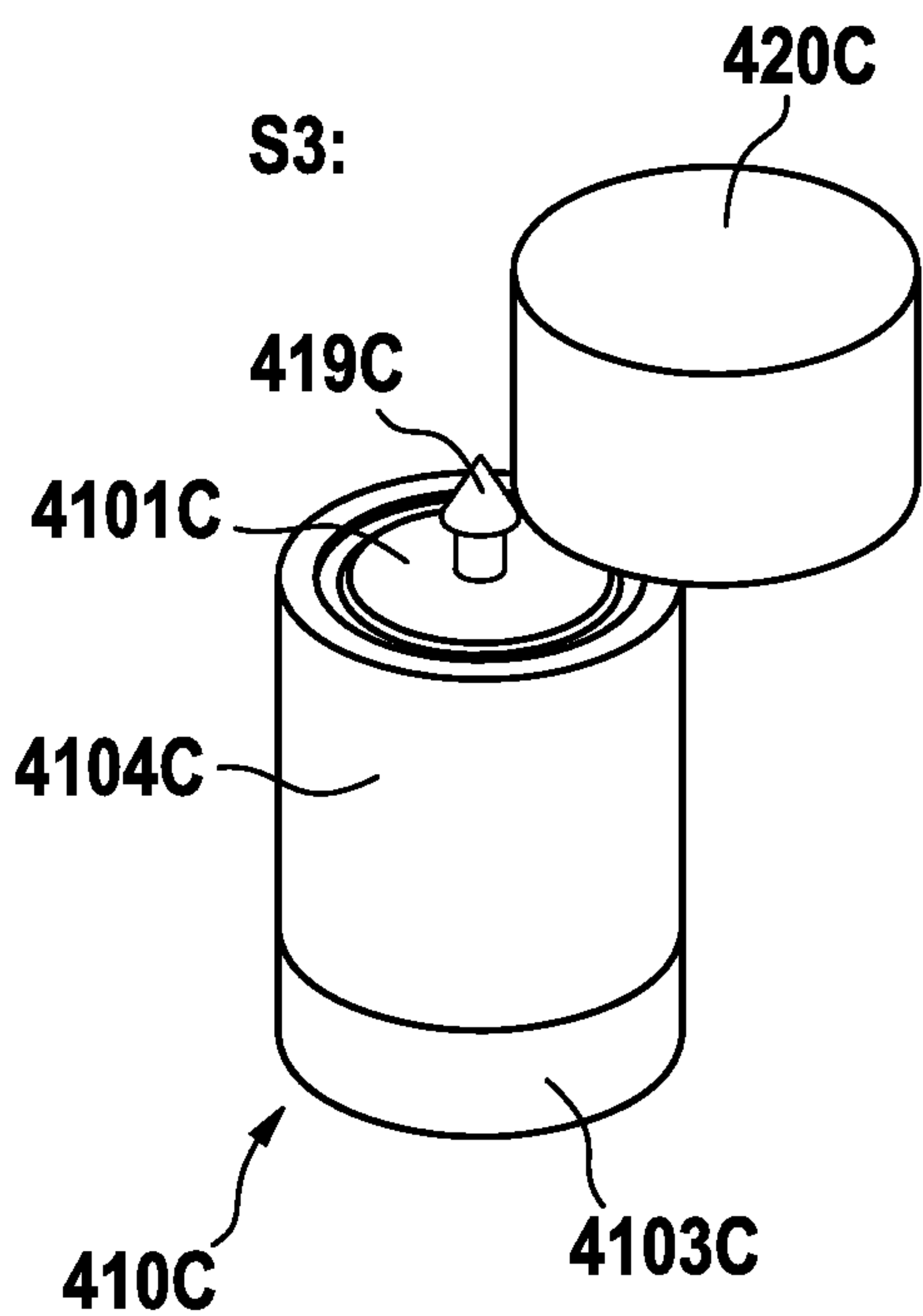

Fig. 6C

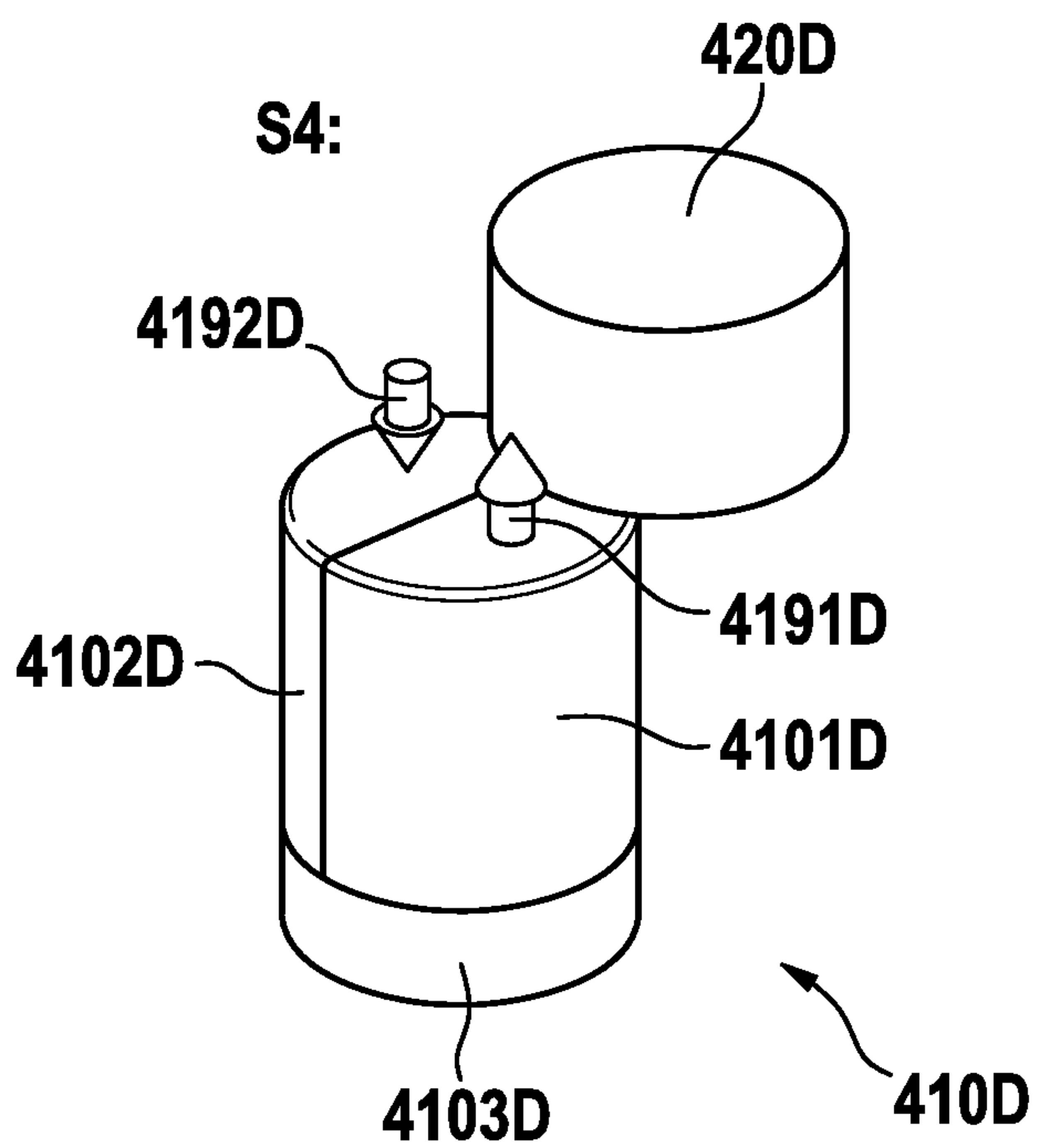

Fig. 6D

Fig. 7

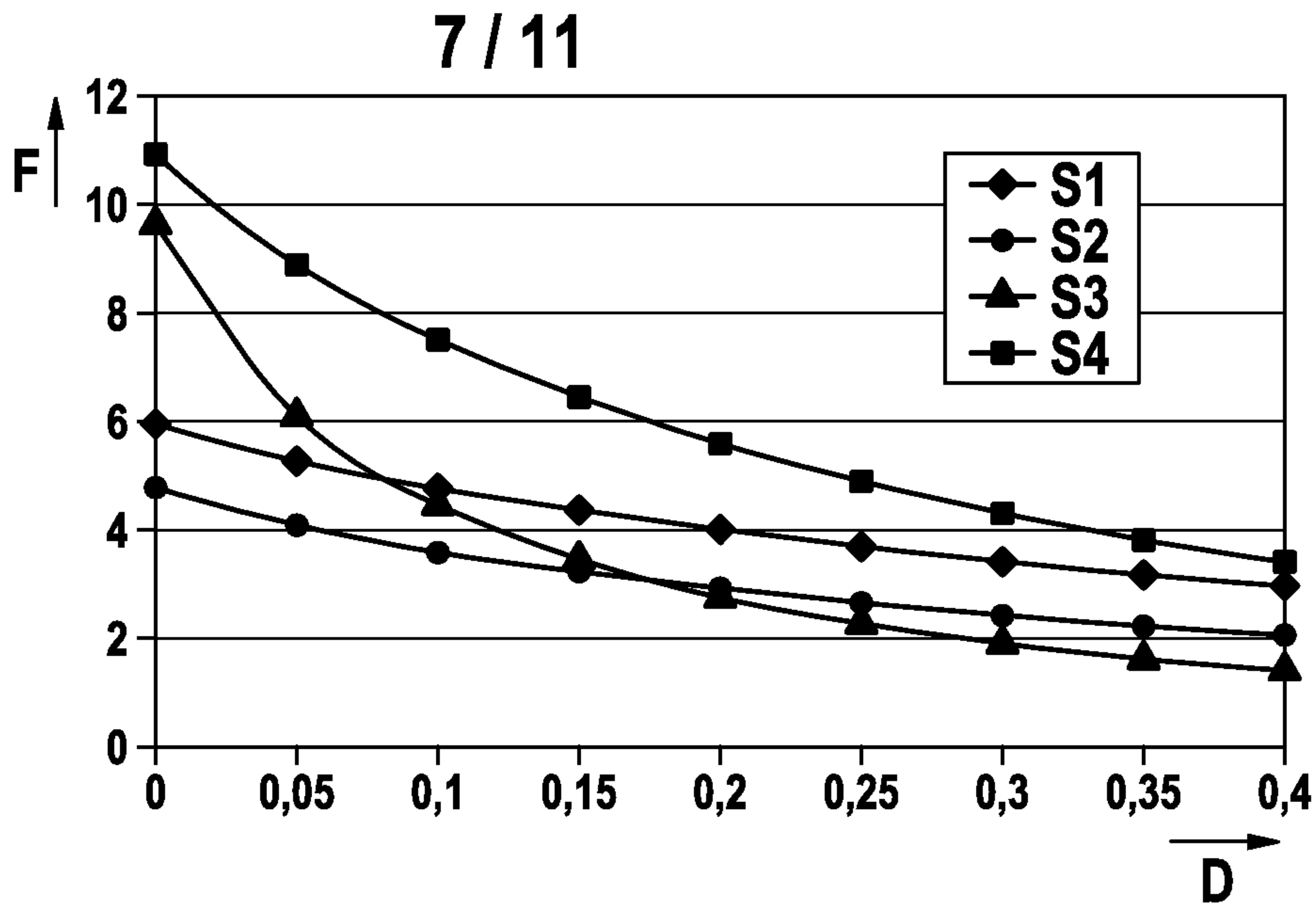

Fig. 8

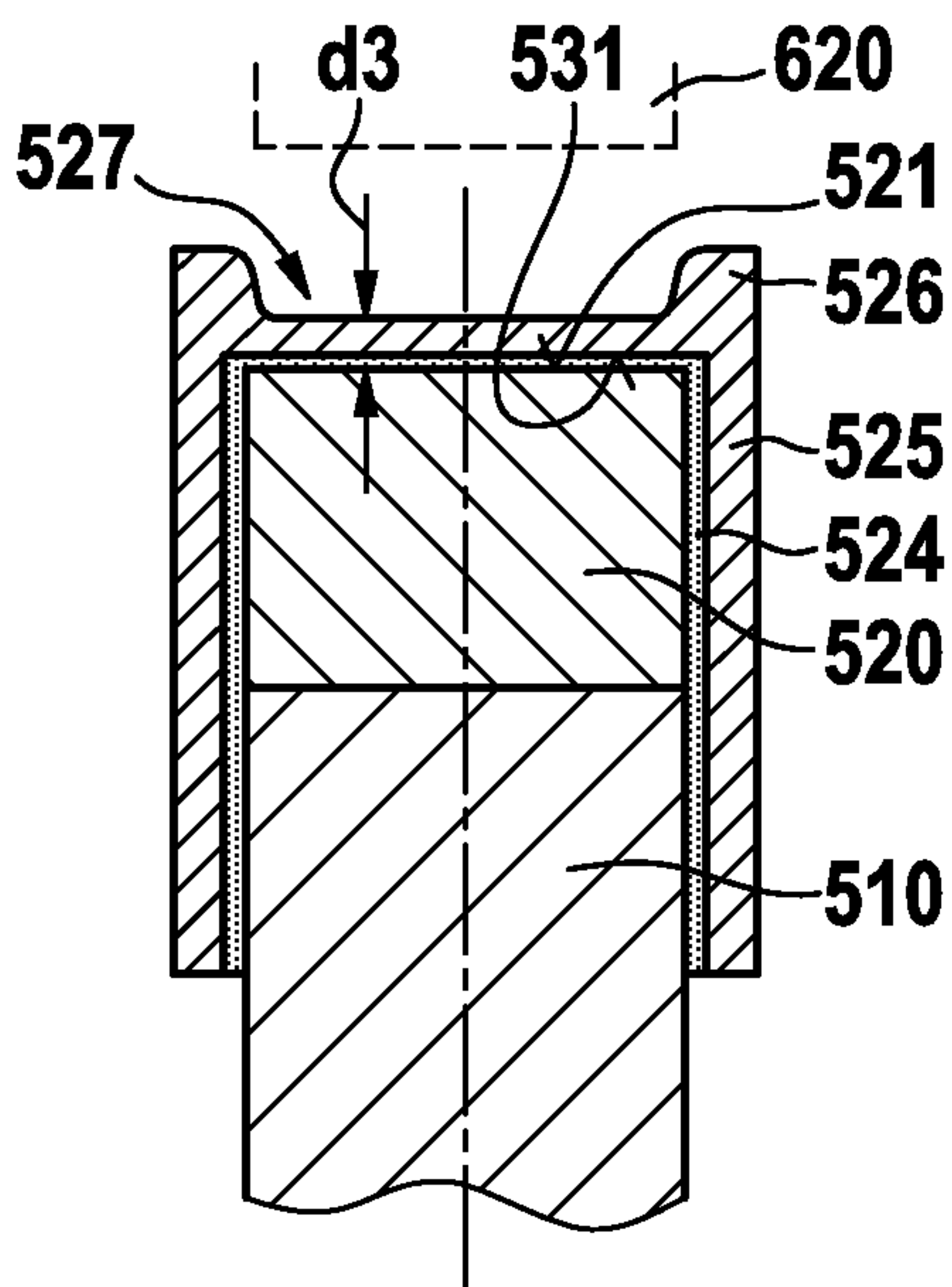
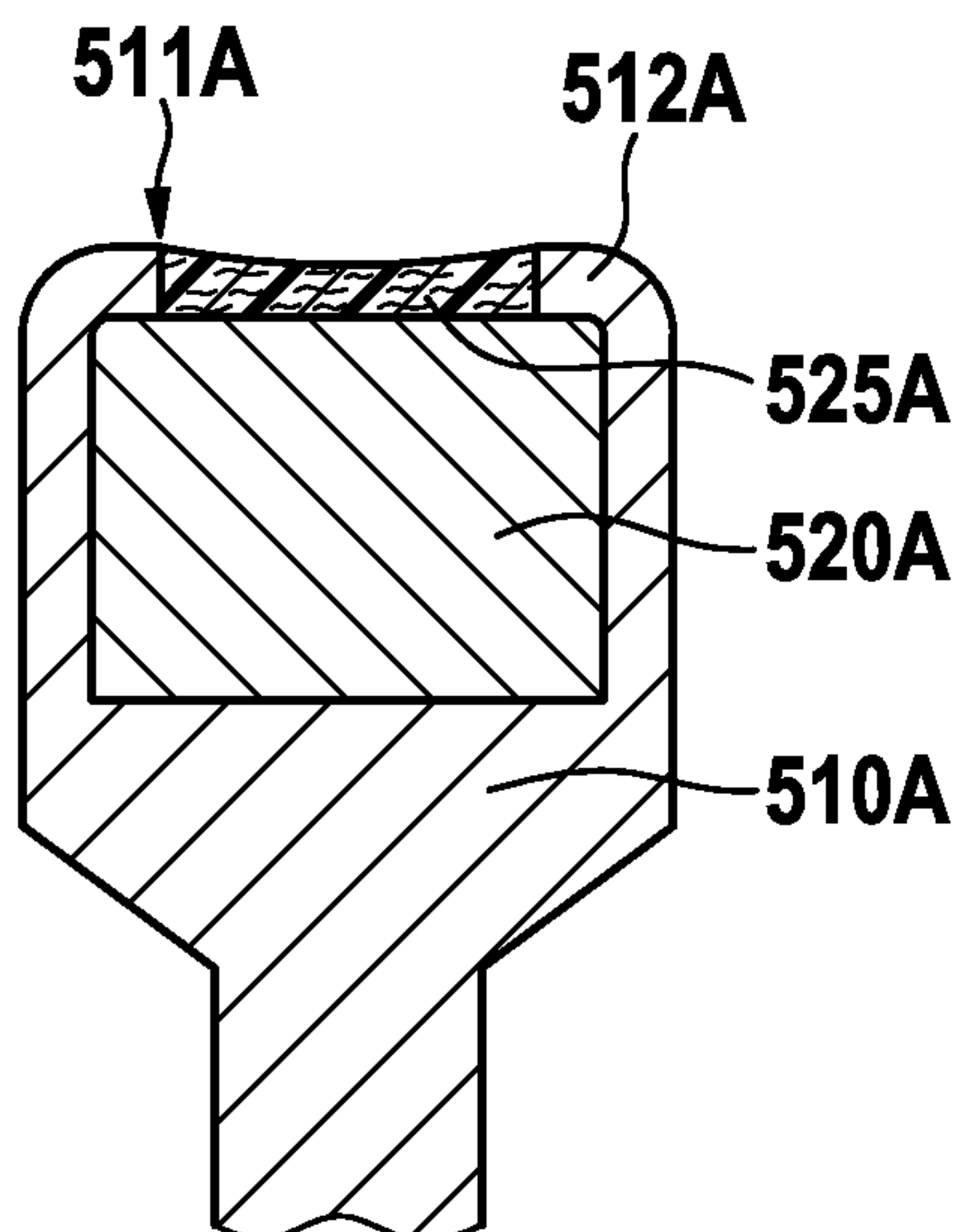

Fig. 9



8 / 11

Fig. 10

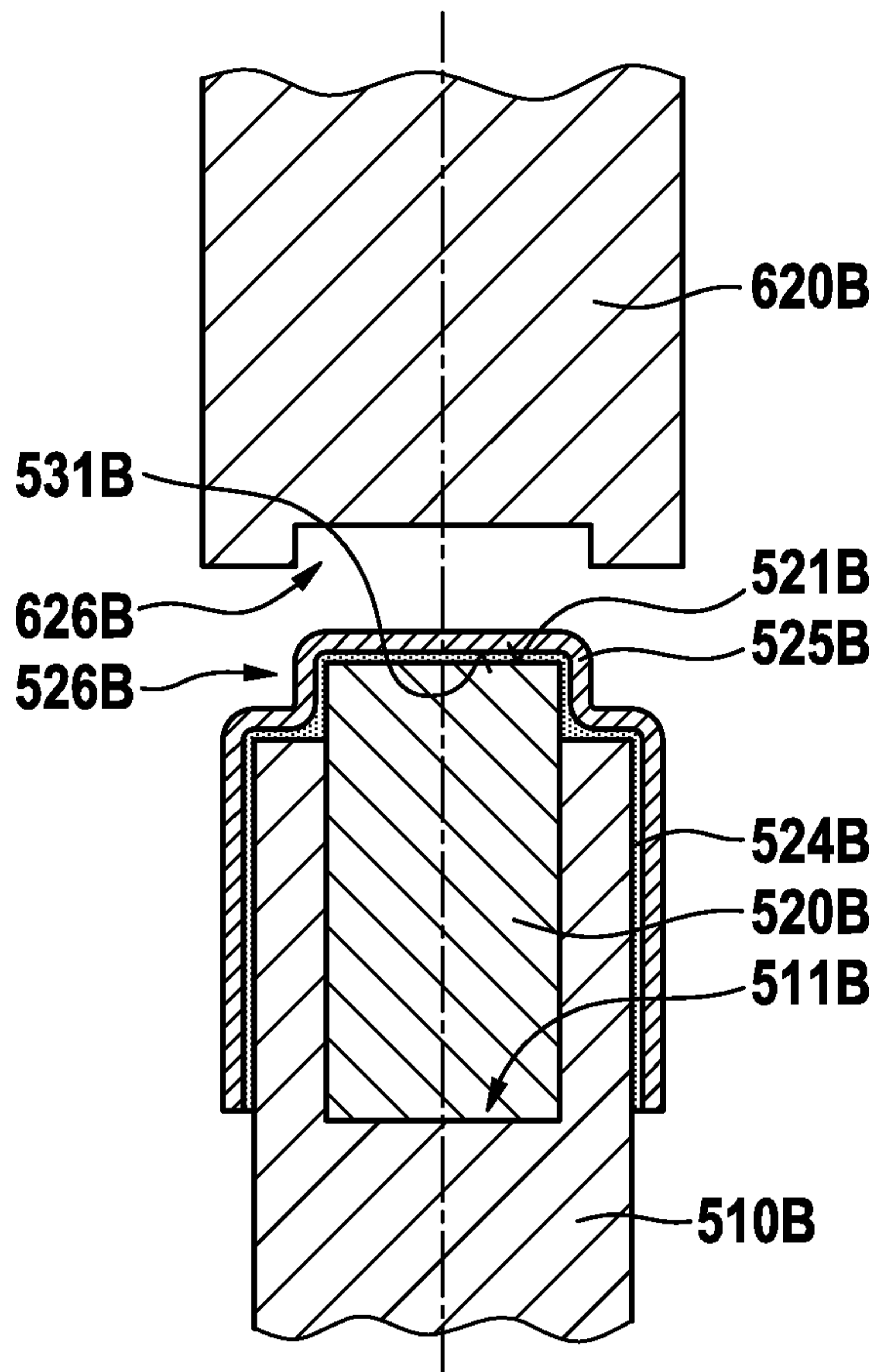
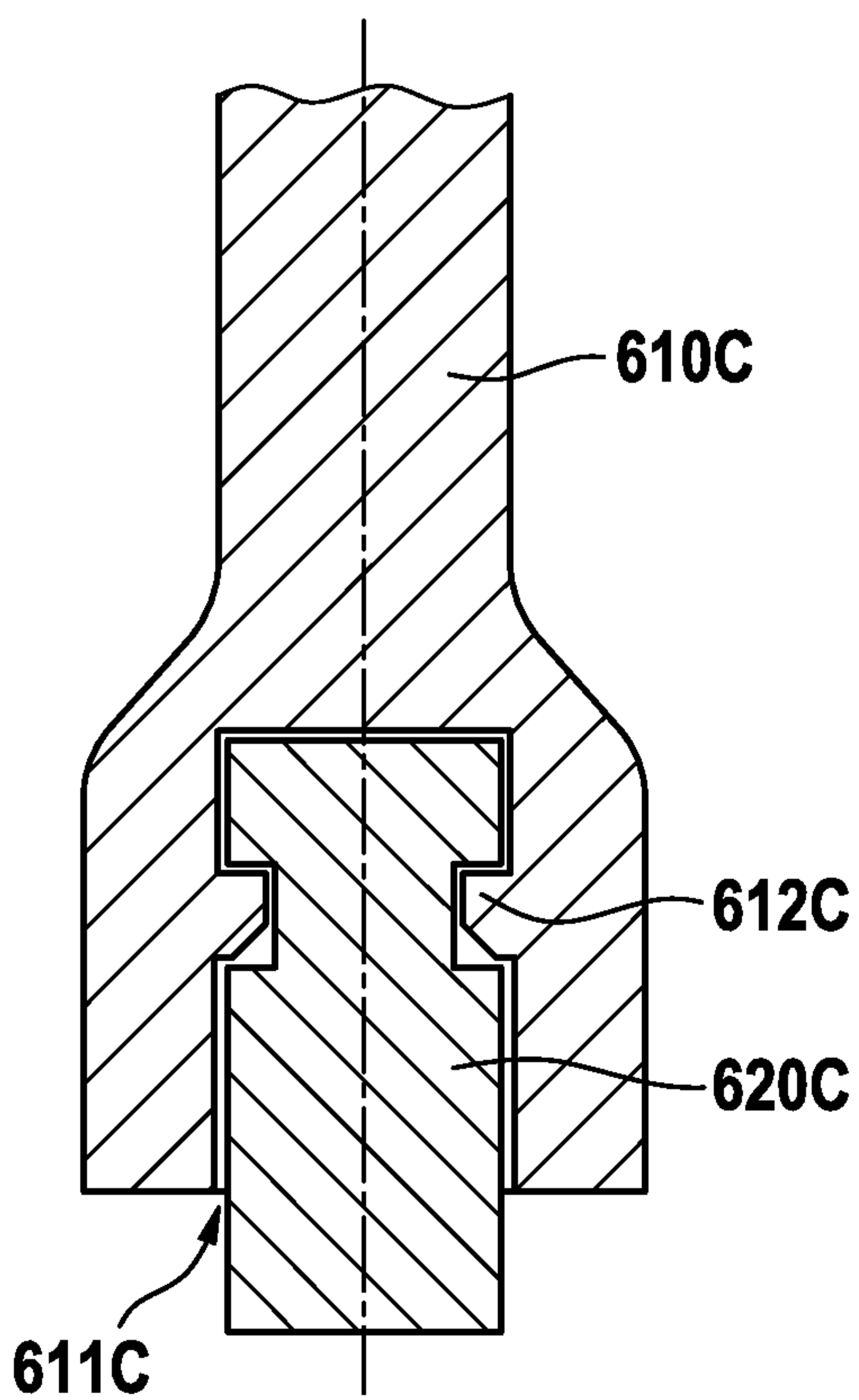
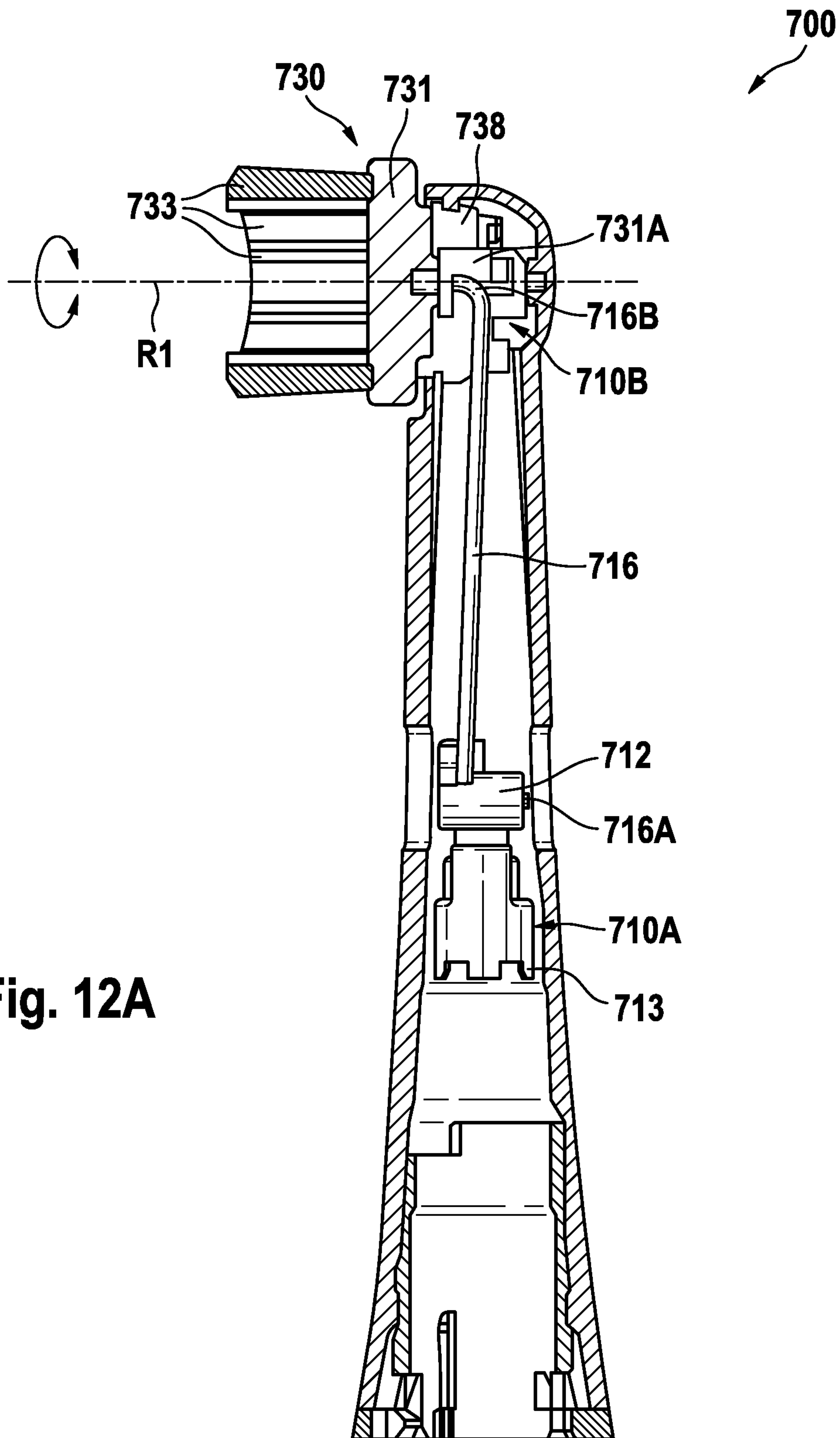

Fig. 11



9 / 11



10 / 11

