



(11) **EP 2 322 701 B1**

(12) **EUROPEAN PATENT SPECIFICATION**

(45) Date of publication and mention of the grant of the patent:
13.03.2013 Bulletin 2013/11

(51) Int Cl.:
D01G 7/10^(2006.01) D01G 7/14^(2006.01)

(21) Application number: **10181313.7**

(22) Date of filing: **28.09.2010**

(54) **Device and method for the automatic pick-up of fibre from a bale of fibre on a spinning line**

Vorrichtung und Verfahren zur automatischen Aufnahme einer Faser aus einem Faserballen auf einer Rolle

Dispositif et procédé pour la capture automatique de fibres d'une balle de fibres sur une chaîne de filature

(84) Designated Contracting States:
AL AT BE BG CH CY CZ DE DK EE ES FI FR GB GR HR HU IE IS IT LI LT LU LV MC MK MT NL NO PL PT RO SE SI SK SM TR

(30) Priority: **16.11.2009 IT BS20090208**

(43) Date of publication of application:
18.05.2011 Bulletin 2011/20

(73) Proprietor: **Marzoli S.p.A.**
25036 Palazzolo Sull'Oglio, Brescia (IT)

(72) Inventors:
• **Mascheretti, Mario**
I-25036, Palazzolo sull'Oglio, BRESCIA (IT)
• **Raccagni, Daniele**
I-25036, Palazzolo sull'Oglio, BRESCIA (IT)

(74) Representative: **Pulieri, Gianluca Antonio**
Jacobacci & Partners S.p.A.
Piazza della Vittoria, 11
25122 Brescia (IT)

(56) References cited:
EP-A1- 0 326 913 EP-A1- 1 571 244
GB-A- 2 282 152

EP 2 322 701 B1

Note: Within nine months of the publication of the mention of the grant of the European patent in the European Patent Bulletin, any person may give notice to the European Patent Office of opposition to that patent, in accordance with the Implementing Regulations. Notice of opposition shall not be deemed to have been filed until the opposition fee has been paid. (Art. 99(1) European Patent Convention).

Description

[0001] The present invention relates to a device and method for the automatic pick-up of fibre from a bale of fibre on a textile processing line.

[0002] Picking fibre in tufts from the bales is the first stage of the process which leads to the formation of yarn from fibre.

[0003] It is rare for all the bales to have the same geographical provenance or be composed of the same fibres; normally, in fact since natural fibre has characteristics which are highly dependent on the place of origin and the type of plant, fibres are mixed to obtain a final yarn having the desired quality characteristics and to minimise production costs.

[0004] Usually, in addition, synthetic fibres or fibres derived from production discards, such as "pigneuse" fibre derived from combing discards, are processed.

[0005] The bales are usually positioned in a row along the side of the pick-up device and are not all the same height, so that, when placed in a row, they have a staggered outline. In addition, the bales are not the same density, precisely on account of their different provenance and quality of the fibre. Within the same bale, moreover, differences in density occur, being less dense on the free upper surface (that is the bale is softer on the surface) and denser in the middle (the bale, that is, in the centre).

[0006] The pick-up device is usually composed of a column translating on tracks, which the row of bales flanks; the column bears a swing arm which passes over the bales and picks up a layer of fibre, usually using rotating rollers fitted with tips. The column has an outbound and a return movement along the tracks, so that at each passage the arm picks up a layer of fibre.

[0007] One example of a pick-up device is described, for example in document EP-A1-1571244, in the name of the Applicant.

[0008] As has been said, the outline of the bales is staggered and the density of the fibre is not constant.

[0009] To perform pick-up from a row of bales, some pick-up devices foresee setting of the height at which to commence pick-up and the thickness of the layer to be picked; at each passage the machine lowers the arm to pick up a further layer. During a single passage, the height of the arm remains constant.

[0010] Such devices can cause problems, especially on start-up of the process, when the outline is staggered, and on account of the different densities of the fibre.

[0011] The B12N device manufactured by Marzoli S.p.A. is, instead, an automatic pick-up device, fitted with an arm the height of which is regulated depending on the pressure of the arm on the bale; such device operates perfectly even on start-up of the process.

[0012] The purpose of the present invention is to further improve an automatic device and to identify an improved method for picking up fibre from bales of fibre.

[0013] Such purpose is achieved by a pick-up device

comprising:

[0014] - an arm able to translate above the bales along a horizontal pick-up axis, fitted with pick-up means able to pick-up the fibre from the free surface of the bales;

5 **[0015]** - transport means able to transport the picked-up fibre to subsequent processes, said transport means being operatively connected to said pick-up means;

10 **[0016]** - actuation means able to move the arm vertically in a controlled manner;

[0017] - first control means able to condition the actuation means to control the vertical movement of the arm on the basis of the values of a first set of parameters which define the state of the bales or of the pick-up device;

15 **[0018]** - second control means able to condition the actuation means to control the vertical movement of the arm on the basis of the values of a second set of parameters which define the state of the bales or of the pick-up device;

20 **[0019]** - enabling means able to activate the first control means or the second control means according to the values of a set of selection parameters, which define a state of the bales or of the pick-up device, to condition said actuation means by means of the first control means or the second control means.

[0020] Such purpose is also achieved by an automatic method comprising the phases of:

30 **[0021]** - moving an arm fitted with pick-up means onto the bales of fibre and picking-up a layer of fibre;

[0022] - moving the arm vertically in a controlled manner;

35 **[0023]** wherein the phase of moving the arm vertically in a controlled manner takes place alternatively by

[0024] a) controlling the vertical movement of the arm on the basis of the values of a first set of parameters which define the state of the bales or of the pick-up device;

[0025] or

40 **[0026]** b) controlling the vertical movement of the arm on the basis of the values of a second set of parameters which define the state of the bales or of the pick-up device;

45 **[0027]** - selecting mode a) or b) according to the values of a set of selection parameters which define the state of the bales or of the pick-up device.

[0028] The characteristics and advantages of the device and of the method according to the present invention will be evident from the following description made by way of a non-limiting example, with reference to the attached drawings, wherein:

50 **[0029]** - figure 1 shows an axonometric view of a pick-up device of fibre from a bale of fibre according to the present invention, according to a preferred embodiment;

[0030] - figure 2 shows a functioning diagram of the pick-up device according to the present invention;

[0031] - figure 3 shows a diagram of an arm of the

pick-up device according to the present invention;

[0032] - figures 4a and 4c show pick-up phases.

[0033] With reference to the attached figures, reference numeral 1 globally denotes a pick-up unit on a fibre processing line.

[0034] The unit 1 comprises a track 2 having a main extension along a translation axis X. The bales of fibre are positioned along the track 2, along one or both sides of said track, sometimes continuously, sometimes distanced from each other. Such bales occupy a pick-up area, alongside the track 2, on the ground.

[0035] Preferably, the unit 1 comprises an expulsion duct 3, communicating with further devices downstream of the pick-up device, performing subsequent processing or air aspiration. For example, the expulsion duct 3 is positioned between the rails of the track 2.

[0036] The unit 1 further comprises a pick-up device 4, resting on the track 2 and translatable upon command along it.

[0037] In particular, the device 4 comprises a carriage 6, for example fitted with wheels, resting on the track 2, and a column 8 having its main extension along a vertical axis Y, resting on the carriage 6.

[0038] The device 4 further comprises an arm 10 jutting out from the column so as to lie over the pick-up area where the bales are positioned; in other words the arm is shaped like a flag.

[0039] According to one embodiment, the column 8 or the arm 10 can rotate around the vertical axis Y, to pick up fibre from the bales positioned on one or other side of the track 2.

[0040] The pick-up device 4 further comprises pick-up means of the fibre from the bales, such as at least one pick-up roller of fibre from the bale, supported by the arm 10.

[0041] Preferably, the device 4 comprises a pair of pick-up rollers 11a, 11b rotating upon command around respective longitudinally distanced rotation axes 11c, 11d. The pick-up rollers 11a, 11b are equipped on the surface with tips 12 able to tear the fibre from the bales.

[0042] Preferably, in addition, the device 4 comprises a cage 14 fitted with pressure bars 14a having a longitudinal extension and positioned vertically, distanced from the rotation axes 11c, 11d, so that the tips of these project below the bars 14a to tear off the fibre.

[0043] According to a preferred embodiment, the relative distance between the pressure bars 14a and the rotation axes 11c, 11d of the rollers 11a, 11b is adjustable for example by means of an electric motor fitted onto the arm 10.

[0044] The device 4 further comprises transport means for transport of the fibre to subsequent processes, such as an aspiration duct 16 having an aspiration aperture at the point of the pick-up rollers 11a, 11b to aspirate the fibre picked up by the tips 12 from the rollers.

[0045] Preferably, the aspiration duct 16 is housed in the arm 10 and the rollers 11a, 11b are contained therein, it extends further in the column 8 and is in communication,

even while the column 8 is in translation, with the expulsion duct 3, to bring the fibre to subsequent processes.

[0046] The arm 10 can translate vertically upon command along the column 8.

5 **[0047]** In particular, the device 1 comprises transmission means able to move the arm vertically, sliding along the column and actuation means able to drive the transmission.

10 **[0048]** For example, the actuation means comprise an electric motor 12, preferably a permanent magnet synchronous feedback motor, that is provided with feedback means 13, for example fitted on the pick-up device 4, and a processing device 13a to send the motor 12 the actuation signals.

15 **[0049]** In particular, the feedback means of the electric motor 12, comprise a resolver and/or encoder operatively connected to the motor shaft.

20 **[0050]** The transmission means further comprise, for example, sliding guides which the arm 10 slides on, and a kinematic chain able to transform the rotatory movement of the motor shaft into a vertical translatory movement of the arm 10.

25 **[0051]** Furthermore, the pick-up device 4 further comprises main control means able to detect the height of the bales and to send respective signals to the actuation means to raise and/or lower the arm so that the pick-up rollers are positioned at the right height to pick-up the layer of fibre of the pre-set thickness from the free upper surface of each bale.

30 **[0052]** For example, upon start-up of the pick-up process, the arm 10 is commanded to pass over the bales, measuring the length of the bales, in other words their extension along the direction of the track, their position and their height. The observed data is for example memorised in an estimation device 18, the estimation device 18 is operatively connected to the actuation means by the processing device 13a.

35 **[0053]** Furthermore, the pick-up device 4 comprises first control means able to condition the actuation means to keep the force of the arm 10 on the bales constant.

40 **[0054]** For example, said first control means comprise the feedback means 13 of the motor 12.

45 **[0055]** In other words, said first control means are able to control the electric motor 12 to function at a constant torque.

[0056] Furthermore, the pick-up device 4 comprises second control means able to condition the actuation means to keep the vertical movement of the arm constant.

50 **[0057]** For example, said second control means comprise the feedback means 13 of the motor 12.

[0058] For example, said second control means are able to command the motor to function at a constant pitch, that is so that at each passage of the arm over the bales, the motor shaft rotates by a pre-set constant angle between one passage and the next.

55 **[0059]** Furthermore, the pick-up device 4 comprises enabling means 26, preferably automatic, able to actuate

the first and second control means to condition the actuation means.

[0060] For example, the enabling means 26 are operatively connected to the feedback means 13 of the motor 12 to receive signals depending on the height of the arm 10 by means of a memorisation device 32 which memorises the heights of the arm at each passage over the bales, and a comparison device 34 which estimates the heights and sends a selection signal according to the values found for the heights.

[0061] For example, the comparison device estimates the containment of the height variation within a pre-set range. If the height variation of the arm falls within the pre-set range, the comparison device 34 sends a selection signal to activate the enabling means 26 enabling control of the actuation means by the second control means.

[0062] According to a further example, the comparison device 34 estimates the lowering of the heights below a pre-set minimum value. If the heights are below a pre-set minimum value, the comparison device 34 sends a further actuation selection signal to the enabling means 26 which enable conditioning of the actuation means by means of the first control means.

[0063] Preferably, moreover, the pick-up device 4 comprises third control means 40 able to adjust the relative position of the pick-up rollers 11a 11b and the cage 14, and in particular the pressure bars 14a of said cage 14. The third control means 40 are operatively connected to the processing device 13a.

[0064] This way, depending on the operating conditions of the device 4 or the characteristics of the bales, the extent of the projection of the tips 12 below the pressure bars 14a can be adjusted, increasing or reducing how far the tips sink into the bales.

[0065] During normal functioning of the pick-up device 4, the bales A-D are initially positioned beside one another, more or less continuously, to the side of the track 2 along the translation axis X in the pick-up area and are of variable height (figure 4a).

[0066] After the initialisation procedures, such as that of identifying the lateral outline of the bales and of their positioning, described above, the actuation means are conditioned by the first control means.

[0067] In other words, initially the electric motor 12 is controlled at a constant torque.

[0068] While the carriage 6 proceeds in the pick-up direction X to perform a passage over the bales, the main control means 18 condition the actuation means so that the arm translates vertically bringing the tips of the pick-up rollers 11a, 11b to lie against the free surface of the bales and the first control means condition the actuation mean so that the arm 10 operates at a constant force on the bales.

[0069] While the carriage 6 proceeds in the pick-up direction X the height of the arm 10 varies, so that the force of the arm on the bales is constant.

[0070] The density of the bales at start-up is low so

that the bale is soft; operating at a constant force therefore constitutes a considerable advantage, in that the bale is compressed by the arm until it resists with a pre-defined force optimal for removal of the fibre. Moreover, by proceeding at a constant force, processing leads to a progressive levelling of the outline of the bales.

[0071] If necessary, the third means of control are also active in such configuration, to vary the penetration of the tips into the fibre by adjusting the relative distance between the pressure bars 14a of the cage 14 and the rotation axes 11c, 11d of the pick-up rollers 11a, 11b.

[0072] For example, the third control means operate to increase pick-up (by bringing the pressure bars 14a of the cage 14 closer to the rotation axes 11c, 11d of the pick-up rollers 11a, 11b) when the arm 10 rises, and vice versa, so as to speed up levelling of the outline of the bales.

[0073] As pick-up proceeds, the bales A-D tend to level out (figure 4b), until they reach a configuration in which the variation of the heights of the bales is contained within a pre-set range (I).

[0074] In such configuration, the comparison device 34 estimates the containment of the heights of the free surfaces of the bales within the pre-set range I and sends a second selection signal to the enabling means 26 so that the second control means are enabled and therefore said second control means condition the actuation means; the actuation means therefore operate so as to keep the lowering of the arm 10 at each passage constant.

[0075] In other words, in such configuration the motor 12 is controlled at a constant pitch which ensures constant lowering of the arm.

[0076] Such condition is particularly advantageous when the bales being processed in this phase are very soft, or contain synthetic or "pigneuse" fibre. The prior machines rather, in such condition, reveal considerable drawbacks, especially if the arm is controlled at a constant force; in such case the arm shows a tendency to sink, pushing to the ground laps of bales or entire bales, especially at the sides of the row of bales.

[0077] Moreover, in such condition the machine according to the invention proves particularly advantageous for processing traditional fibres such as cotton, for which the density of the bales is greater than in the previous condition and operating at a constant pitch is extremely advantageous for maintaining levelling of the outline and speeding up pick-up.

[0078] If necessary, the third means of control are also active in such configuration, to vary the penetration of the tips into the fibre by adjusting the relative distance between the pressure bars 14a of the cage 14 and the rotation axes 11c, 11d of the pick-up rollers 11a, 11b, for example so as to modify the quantity of fibre picked up depending on the demand made by the machines downstream.

[0079] As pick-up proceeds, the bales A-D tend to level out (figure 4c), until they reach a configuration in which

the height of the bales is below a pre-set threshold value L. In this condition, the bales are not high enough to be elastic, feeling the hardness of the floor; the density of the bales is, additionally, once again low.

[0080] In such configuration, the comparison device 34 detects that the height of the arm 10 is below the pre-set threshold value L and sends a first selection signal to the enabling means 26 so that the first control means are enabled and therefore said first control means condition the actuation means; the actuation means therefore operate so as to maintain the force of the arm on the bales constant.

[0081] In other words, in such configuration the motor 12 is again controlled at a constant torque.

[0082] If necessary, the third means of control are also active in such configuration, to vary the penetration of the tips into the fibre by adjusting the relative distance between the pressure bars 14a of the cage 14 and the rotation axes 11c, 11d of the pick-up rollers 11a, 11b.

[0083] In such configuration, it is again extremely advantageous to operate at a constant force, to prevent the residual part of the bales from being torn in segments from the cylinders, in a random, untidy manner.

[0084] Innovatively, the pick-up device and method according to the present invention operate in an excellent manner on all the configurations of the bales, from start-up of pick-up from new bales to the end of pick-up from almost exhausted bales.

[0085] Moreover, the pick-up device and method according to the present invention also operate excellently on bales of fibres of varying origin, that is with natural fibres, such as cotton and with fibres from combing discards or with synthetic fibres.

Claims

1. Pick-up device (4) of fibre from a bale of fibre comprising:
 - an arm (10) able to translate above the bales (A-D) along a horizontal pick-up axis (X), fitted with pick-up means able to pick-up the fibre from the free surface of the bales;
 - transport means able to transport the picked-up fibre to subsequent processes, said transport means being operatively connected to said pick-up means;
 - actuation means able to move the arm (10) vertically in a controlled manner;
 - first control means able to condition the actuation means to control the vertical movement of the arm (10) on the basis of the values of a first set of parameters which define the state of the bales or of the pick-up device;
 - second control means able to condition the actuation means to control the vertical movement of the arm (10) on the basis of the values of a

second set of parameters which define a further state of the bales or of the pick-up device;

- enabling means able to activate the first control means or the second control means according to the values of a set of selection parameters, which define a state of the bales or of the pick-up device, to condition said actuation means by means of the first control means or the second control means.

2. Device according to claim 1, wherein the first control means are able to condition the actuation means to keep the force of the arm (10) on the bales constant.
3. Device according to any of the previous claims, wherein the second control means are able to condition the actuation means to keep the translation of the arm (10) constant at each passage over the bales.
4. Device according to any of the previous claims, wherein the actuation means comprise an electric motor (12).
5. Device according to claim 4, wherein the electric motor is a synchronous feedback motor.
6. Device according to claim 4 or 5, wherein the first control means and/or the second control means comprise the feedback means (13) of the electric motor (12).
7. Device according to claim 5 or 6, wherein the feedback means comprise a resolver and/or encoder mounted on the electric motor.
8. Device according to any of the previous claims, wherein the enabling means are able to detect physical characteristics of the bales or a functioning state of the pick-up device and to send a selection signal, and actuation means (26) able to select the first control means or the second control means to condition the actuation means.
9. Device according to claim 8 when dependent on claim 6, wherein the enabling means are connected to the feedback means by means of a memorisation device (32) which memorises the heights of the arm at each passage over the bales, and a comparison device (34) which estimates the heights and sends a selection signal to the selection means (26) according to the values found for the heights.
10. Device according to claim 9, wherein the comparison device (34) estimates the containment of the height variation within a pre-set range (I) and if the height variation falls within the pre-set range, the selection device sends an activation signal to the enabling

means (26) which enable the control of the actuation means by the second control means.

11. Device according to claim 9 or 10, wherein the comparison device (34) estimates the height of the arm and whether the height is below a pre-set minimum value (L), and sends a further selection signal to actuate the enabling means (26) which enable the conditioning of the actuation means by the first control means.
12. Device according to any of the previous claims, comprising control means able to detect the height of the bales and to send respective signals to the actuation means to raise and/or lower the arm so that the pick-up means are positioned at the right height to pick up a layer of fibre from the free upper surface of each bale.
13. Device according to claim 12 when dependent on claim 6, wherein the main control means comprise the feedback mechanisms of the electric motor and an estimation device (18) to process the signals coming from feedback mechanisms, wherein the estimation device (18) is operatively connected to the actuation means.
14. Device according to any of the previous claims, comprising third control means (40) for the adjustment of the relative distance between pressure bars (14a) of a cage (14) and the rotation axes (11c,11d) of pick-up rollers (11a,11b), to regulate the projection of the tips (12) of the pick-up rollers (11a, 11b) below said pressure bars (14a).
15. Device according to any of the previous claims, comprising a track (2), a carriage (6) translating on said track and a column (8) resting on the carriage (6), from which the arm (10) juts out in the shape of a flag.
16. Device according to claim 15, wherein the column (8) or the arm (10) can rotate around a vertical axis (Y) to pick-up fibre from the bales positioned on one side or the other of the track.
17. Device according to any of the previous claims, wherein the pick-up means comprise at least one motorised pick-up roller (11a, 11b), supported by the arm (10), equipped on the surface with tips (12) able to tear the fibre from the bales.
18. Device according to any of the previous claims, wherein the transport means comprise an aspiration duct (16) having an aspiration aperture at the point of the pick-up means.
19. Method for the automatic pick-up of fibre from bales of fibre, comprising the phases of:

- moving an arm (10) fitted with pick-up means onto the bales of fibre and picking-up a layer of fibre;

- moving the arm (10) vertically in a controlled manner; wherein the phase of moving the arm vertically in a controlled manner takes place alternatively by

a) controlling the vertical movement of the arm (10) on the basis of the values of a first set of parameters which define the state of the bales or of the pick-up device;

or

b) controlling the vertical movement of the arm (10) on the basis of the values of a second set of parameters, which define a further state of the bales or of the pick-up device;

- selecting mode a) or b) according to the values of a set of selection parameters, which define a state of the bales or of the pick-up device.

25 Patentansprüche

1. Aufnahmevorrichtung (4) für Faser aus einem Faserballen, die umfasst:

- einen Arm (10), der fähig ist, über den Ballen (A-D) entlang einer horizontalen Aufnahmeachse (X) verschoben zu werden, der mit Aufnahmemitteln ausgestattet ist, die fähig sind, die Faser von der freien Oberfläche der Ballen aufzunehmen;

- Transportmittel, die fähig sind, die aufgenommene Faser zu anschließenden Verfahren zu transportieren, wobei die Transportmittel betriebsfähig mit dem Aufnahmemittel verbunden sind;

- Betätigungsmittel, die fähig sind, den Arm (10) in einer gesteuerten Weise vertikal zu bewegen;

- erste Steuermittel, die fähig sind, die Betätigungsmittel vorzubereiten, um die vertikale Bewegung des Arms (10) auf der Basis der Werte eines ersten Satzes von Parametern, die den Zustand der Ballen oder der Aufnahmevorrichtung definieren, zu steuern;

- zweite Steuermittel, die fähig sind, die Betätigungsmittel vorzubereiten, um die vertikale Bewegung des Arms (10) auf der Basis der Werte eines zweiten Satzes von Parametern, die einen weiteren Zustand der Ballen oder der Aufnahmevorrichtung definieren, zu steuern;

- Aktivierungsmittel, die fähig sind, die ersten Steuermittel oder die zweiten Steuermittel gemäß den Werten eines zweiten Satzes von Auswahlparametern, die einen Zustand der Ballen

- oder der Aufnahmevorrichtung definieren, zu aktivieren, um die Betätigungsmittel mit Hilfe des ersten Steuermittels oder des zweiten Steuermittels vorzubereiten.
2. Vorrichtung nach Anspruch 1, wobei die ersten Steuermittel fähig sind, die Betätigungsmittel vorzubereiten, um die Kraft des Arms (10) auf den Ballen konstant zu halten.
 3. Vorrichtung nach jedem der vorhergehenden Ansprüche, wobei die zweiten Steuermittel fähig sind, die Betätigungsmittel vorzubereiten, um die Verschiebung des Arms (10) bei jedem Durchgang über den Ballen konstant zu halten.
 4. Vorrichtung nach einem der vorhergehenden Ansprüche, wobei die Betätigungsmittel einen Elektromotor (12) umfassen.
 5. Vorrichtung nach Anspruch 4, wobei der Elektromotor ein synchroner Rückkopplungsmotor ist.
 6. Vorrichtung nach Anspruch 4 oder 5, wobei die ersten Steuermittel und/oder die zweiten Steuermittel die Rückkopplungsmittel (13) des Elektromotors (12) umfassen.
 7. Vorrichtung nach Anspruch 5 oder 6, wobei die Rückkopplungsmittel einen Drehmelder und/oder Messgeber, die auf dem Elektromotor montiert sind, umfassen.
 8. Vorrichtung nach einem der vorhergehenden Ansprüche 4 bis 7, wobei die Aktivierungsmittel fähig sind, physikalische Charakteristiken der Ballen oder einen Funktionszustand der Aufnahmevorrichtung zu erfassen und ein Auswahlsignal zu senden, und Betätigungsmittel (26) fähig sind, die ersten Steuermittel oder die zweiten Steuermittel auszuwählen, um die Betätigungsmittel vorzubereiten.
 9. Vorrichtung nach Anspruch 8 in Abhängigkeit von Anspruch 6, wobei die Aktivierungsmittel mittels einer Speichervorrichtung (32), welche die Höhen des Arms bei jedem Durchgang über den Ballen speichert, und einer Vergleichsvorrichtung (34), welche die Höhen schätzt und gemäß den für die Höhen bestimmten Werten ein Auswahlsignal an die Auswahlmittel (26) sendet, verbunden sind.
 10. Vorrichtung nach Anspruch 9, wobei die Vergleichsvorrichtung (34) die Begrenzung der Höhenschwankung innerhalb eines voreingestellten Bereichs (I) schätzt, und die Auswahlvorrichtung, wenn die Höhenschwankung in den voreingestellten Bereich fällt, ein Aktivierungssignal an die Aktivierungsmittel (36) sendet, welche die Steuerung der Betätigungsmittel durch die zweiten Steuermittel aktivieren.
 11. Vorrichtung nach Anspruch 9 oder 10, wobei die Vergleichsvorrichtung (34) die Höhe des Arms und, ob die Höhe unter einem vorher festgelegten Minimumwert (L) ist, schätzt und ein weiteres Auswahlsignal sendet, um die Aktivierungsmittel (26) zu betätigen, welche die Vorbereitung der Betätigungsmittel durch die ersten Steuermittel aktivieren.
 12. Vorrichtung nach einem der vorhergehenden Ansprüche, die Steuermittel umfassen, die fähig sind, die Höhe der Ballen zu erfassen und die jeweiligen Signale an die Betätigungsmittel zu senden, um den Arm zu heben und/oder zu senken, so dass die Aufnahmemittel auf der richtigen Höhe positioniert sind, um eine Faserschicht von der freien oberen Oberfläche jedes Ballens aufzunehmen.
 13. Vorrichtung nach Anspruch 12 in Abhängigkeit von Anspruch 6, wobei die Hauptsteuermittel die Rückkopplungsmechanismen des Elektromotors und eine Schätzvorrichtung (18) umfassen, um die von Rückkopplungsmechanismen kommenden Signale zu verarbeiten, wobei die Schätzvorrichtung (18) betriebsfähig mit den Betätigungsmitteln verbunden ist.
 14. Vorrichtung nach einem der vorhergehenden Ansprüche, die dritte Steuermittel (40) für die Einstellung des relativen Abstands zwischen Drückerstangen (14a) eines Korbs (14) und den Drehachsen (11c, 11d) der Aufnahmerollen (11a, 11b) umfasst, um den Überstand der Spitzen (12) der Aufnahmerollen (11a, 11b) unter den Drückerstangen (14a) zu regulieren.
 15. Vorrichtung nach einem der vorhergehenden Ansprüche, die eine Führung (2), einen Schlitten (6), der auf der Führung verschoben wird, und eine auf dem Schlitten (6) ruhende Säule (8) umfasst, von welcher der Arm (10) in der Form einer Fahne herausragt.
 16. Vorrichtung nach Anspruch 15, wobei die Säule (8) oder der Arm (10) sich um eine vertikale Achse (Y) drehen können, um Fasern von den Ballen aufzunehmen, die auf der einen oder der anderen Seite der Führung positioniert sind.
 17. Vorrichtung nach einem der vorhergehenden Ansprüche, wobei die Aufnahmemittel wenigstens eine motorisierte Aufnahmerolle (11a, 11b) umfassen, die von dem Arm (10) gehalten wird, die auf der Oberfläche mit Spitzen (12) ausgerüstet ist, die fähig sind, die Fasern von den Ballen zu reißen.
 18. Vorrichtung nach einem der vorhergehenden Ansprüche, wobei die Transportmittel einen Ansaugka-

nal (16) mit einer Ansaugöffnung an dem Punkt der Aufnahmemittel umfassen.

19. Verfahren zum automatischen Aufnehmen von Fasern von Faserballen, das die folgenden Phasen umfasst:

- Bewegen eines Arms (10), der mit Aufnahmemitteln ausgestattet ist, auf die Faserballen und Aufnehmen einer Faserschicht;
 - vertikales Bewegen des Arms (10) in einer gesteuerten Weise;
 wobei die Phase des vertikalen Bewegens des Arms in einer gesteuerten Weise alternativ stattfindet durch

a) Steuern der vertikalen Bewegung des Arms (10) auf der Basis der Werte eines ersten Satzes von Parametern, die den Zustand der Ballen oder der Aufnahmevorrichtung definieren;

oder

b) Steuern der vertikalen Bewegung des Arms (10) auf der Basis der Werte des zweiten Satzes von Parametern, die einen weiteren Zustand der Ballen oder der Aufnahmevorrichtung definieren;

- Auswählen der Betriebsart a) oder b) gemäß den Werten eines Satzes von Auswahlparametern, die einen Zustand der Ballen oder der Aufnahmevorrichtung definieren.

Revendications

1. Dispositif de capture (4) d'une fibre d'une balle de fibres comprenant :

- un bras (10) pouvant se déplacer au-dessus des balles (A-D) le long d'un axe de capture horizontal (X), équipé d'un moyen de capture pouvant capturer la fibre de la surface libre des balles ;

- un moyen de transport pouvant transporter la fibre capturée jusqu'à des traitements suivants, ledit moyen de transport étant fonctionnellement relié audit moyen de capture ;

- un moyen d'actionnement pouvant déplacer le bras (10) verticalement d'une manière commandée ;

- un premier moyen de commande pouvant conditionner le moyen d'actionnement pour commander le déplacement vertical du bras (10) sur la base des valeurs d'un premier ensemble de paramètres qui définissent l'état des balles ou du dispositif de capture ;

- un deuxième moyen de commande pouvant

conditionner le moyen d'actionnement pour commander le déplacement vertical du bras (10) sur la base des valeurs d'un second ensemble de paramètres qui définissent un autre état des balles ou du dispositif de capture ;

- un moyen d'activation pouvant activer le premier moyen de commande ou le deuxième moyen de commande en fonction des valeurs d'un ensemble de paramètres de sélection, qui définissent un état des balles ou du dispositif de capture, pour conditionner ledit moyen d'actionnement à l'aide du premier moyen de commande ou du deuxième moyen de commande.

2. Dispositif selon la revendication 1, dans lequel le premier moyen de commande peut conditionner le moyen d'actionnement pour maintenir constante la force qu'exerce le bras (10) sur les balles.

3. Dispositif selon l'une quelconque des revendications précédentes, dans lequel le deuxième moyen de commande peut conditionner le moyen d'actionnement pour maintenir constant le déplacement du bras (10) à chaque passage sur les balles.

4. Dispositif selon l'une quelconque des revendications précédentes, dans lequel le moyen d'actionnement comprend un moteur électrique (12).

5. Dispositif selon la revendication 4, dans lequel le moteur électrique est un moteur de réaction synchrone.

6. Dispositif selon la revendication 4 ou 5, dans lequel le premier moyen et/ou le deuxième moyen de commande comprennent le moyen de réaction (13) du moteur électrique (12).

7. Dispositif selon la revendication 5 ou 6, dans lequel le moyen de réaction comprend un résolveur et/ou un codeur montés sur le moteur électrique.

8. Dispositif selon l'une quelconque des revendications précédentes, dans lequel le moyen d'activation peut détecter des caractéristiques physiques des balles ou un état de fonctionnement du dispositif de capture et envoyer un signal de sélection, et le moyen d'actionnement (26) peut sélectionner le premier moyen de commande ou le deuxième moyen de commande pour conditionner le moyen d'actionnement.

9. Dispositif selon la revendication 8 lorsqu'elle dépend de la revendication 6, dans lequel le moyen d'activation est relié au moyen de réaction à l'aide d'un dispositif de mémorisation (32) qui mémorise les hauteurs du bras à chaque passage sur les balles, et un dispositif de comparaison (34) qui évalue les hauteurs et envoie un signal de sélection au moyen

- de sélection (26) en fonction des valeurs trouvées pour les hauteurs.
- 10.** Dispositif selon la revendication 9, dans lequel le dispositif de comparaison (34) évalue le confinement de la variation de hauteur dans une plage prédéfinie (I) et si la variation de hauteur tombe dans la plage prédéfinie, le dispositif de sélection envoie un signal d'activation au moyen d'activation (26) qui active la commande du moyen d'actionnement par le deuxième moyen de commande.
- 11.** Dispositif selon la revendication 9 ou 10, dans lequel le dispositif de comparaison (34) évalue la hauteur du bras et détermine si la hauteur se trouve sous une valeur minimale prédéfinie (L), et envoie un autre signal de sélection pour actionner le moyen d'activation (26) qui active le conditionnement du moyen d'actionnement par le premier moyen de commande.
- 12.** Dispositif selon l'une quelconque des revendications précédentes, comprenant un moyen de commande pouvant détecter la hauteur des balles et envoyer des signaux respectifs au moyen d'actionnement pour élever et/ou abaisser le bras de sorte que le moyen de capture soit positionné à la bonne hauteur afin de capturer une couche de fibre de la surface supérieure libre de chaque bale.
- 13.** Dispositif selon la revendication 12 lorsqu'elle dépend de la revendication 6, dans lequel le moyen de commande principal comprend les mécanismes de rétroaction du moteur électrique et un dispositif d'évaluation (18) pour traiter les signaux provenant des mécanismes de rétroaction, le dispositif d'évaluation (18) étant fonctionnellement relié au moyen d'actionnement.
- 14.** Dispositif selon l'une quelconque des revendications précédentes, comprenant un troisième moyen de commande (40) destiné au réglage de la distance relative entre les barres de pression (14a) d'une cage (14) et les axes de rotation (11c, 11d) de rouleaux de capture (11a, 11b), afin de réguler la projection des pointes (12) des rouleaux de capture (11a, 11b) sous lesdites barres de pression (14a).
- 15.** Dispositif selon l'une quelconque des revendications précédentes, comprenant un rail (2), un chariot (6) se déplaçant sur ledit rail et une colonne (8) reposant sur le chariot (6), depuis laquelle le bras (10) fait saillie sous la forme d'un drapeau.
- 16.** Dispositif selon la revendication 15, dans lequel la colonne (8) ou le bras (10) peut tourner autour d'un axe vertical (Y) afin de capturer une fibre des balles positionnées sur un côté ou l'autre du rail.
- 17.** Dispositif selon l'une quelconque des revendications précédentes, dans lequel le moyen de capture comprend au moins un rouleau de capture motorisé (11a, 11b), soutenu par le bras (10), équipé, sur la surface, de pointes (12) pouvant arracher la fibre des balles.
- 18.** Dispositif selon l'une quelconque des revendications précédentes, dans lequel le moyen de transport comprend un conduit d'aspiration (16) possédant une ouverture d'aspiration à l'endroit du moyen de capture.
- 19.** Procédé pour la capture automatique d'une fibre de balles de fibres, comprenant les phases consistant à :
- déplacer un bras (10) équipé d'un moyen de capture sur les balles de fibres et capturer une couche de fibre ;
 - déplacer le bras (10) verticalement d'une manière commandée ;
- dans lequel la phase de déplacement du bras verticalement d'une manière commandée a lieu, en variante, par
- a) la commande du déplacement verticale du bras (10) sur la base des valeurs d'un premier ensemble de paramètres qui définissent l'état des balles ou du dispositif de capture ;
 - ou
 - b) la commande du déplacement vertical du bras (10) sur la base des valeurs d'un second ensemble de paramètres qui définissent un autre état des balles ou du dispositif de capture ;
- sélectionner le mode a) ou b) en fonction des valeurs d'un ensemble de paramètres de sélection, qui définissent un état des balles ou du dispositif de capture.

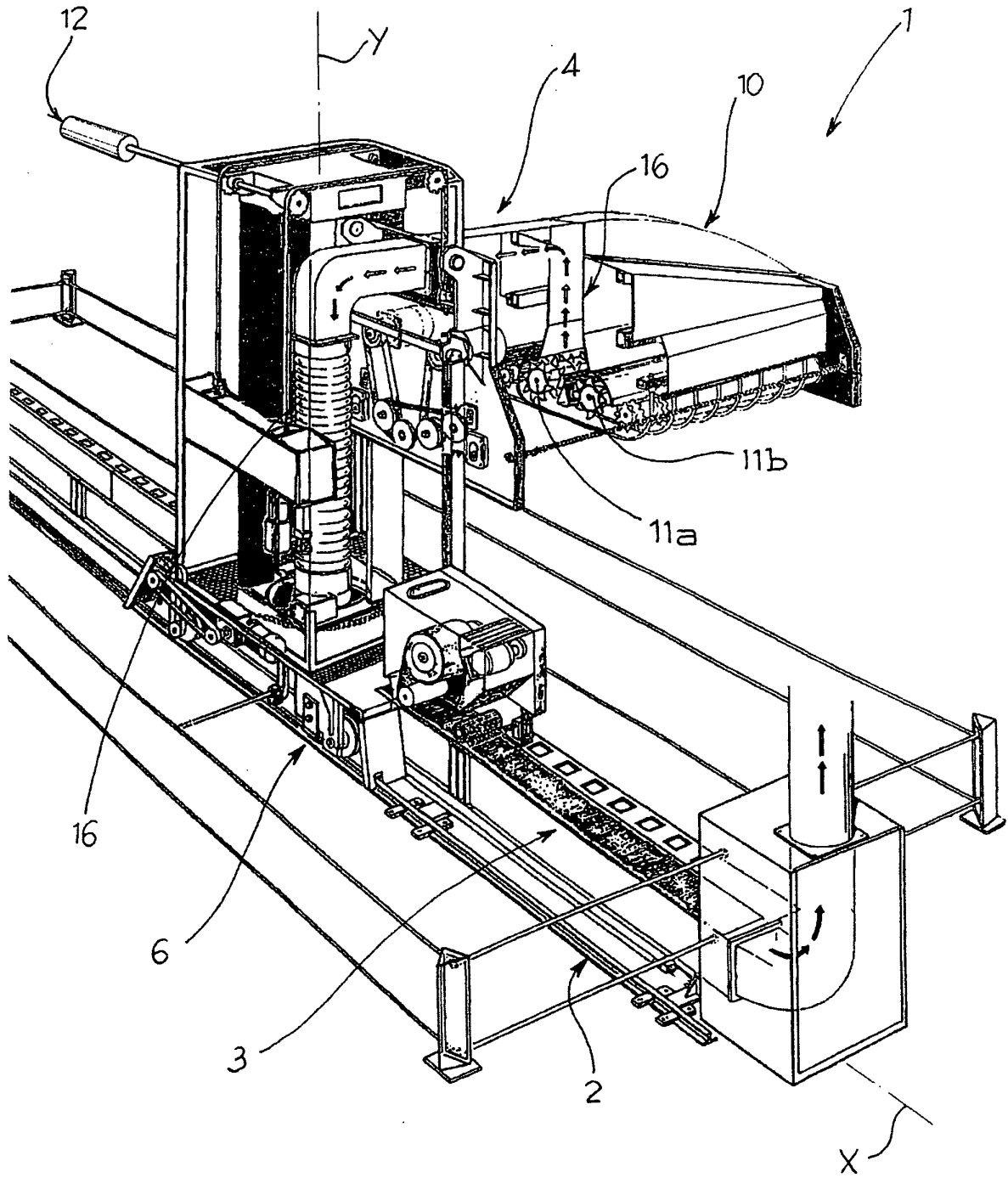

Fig. 1

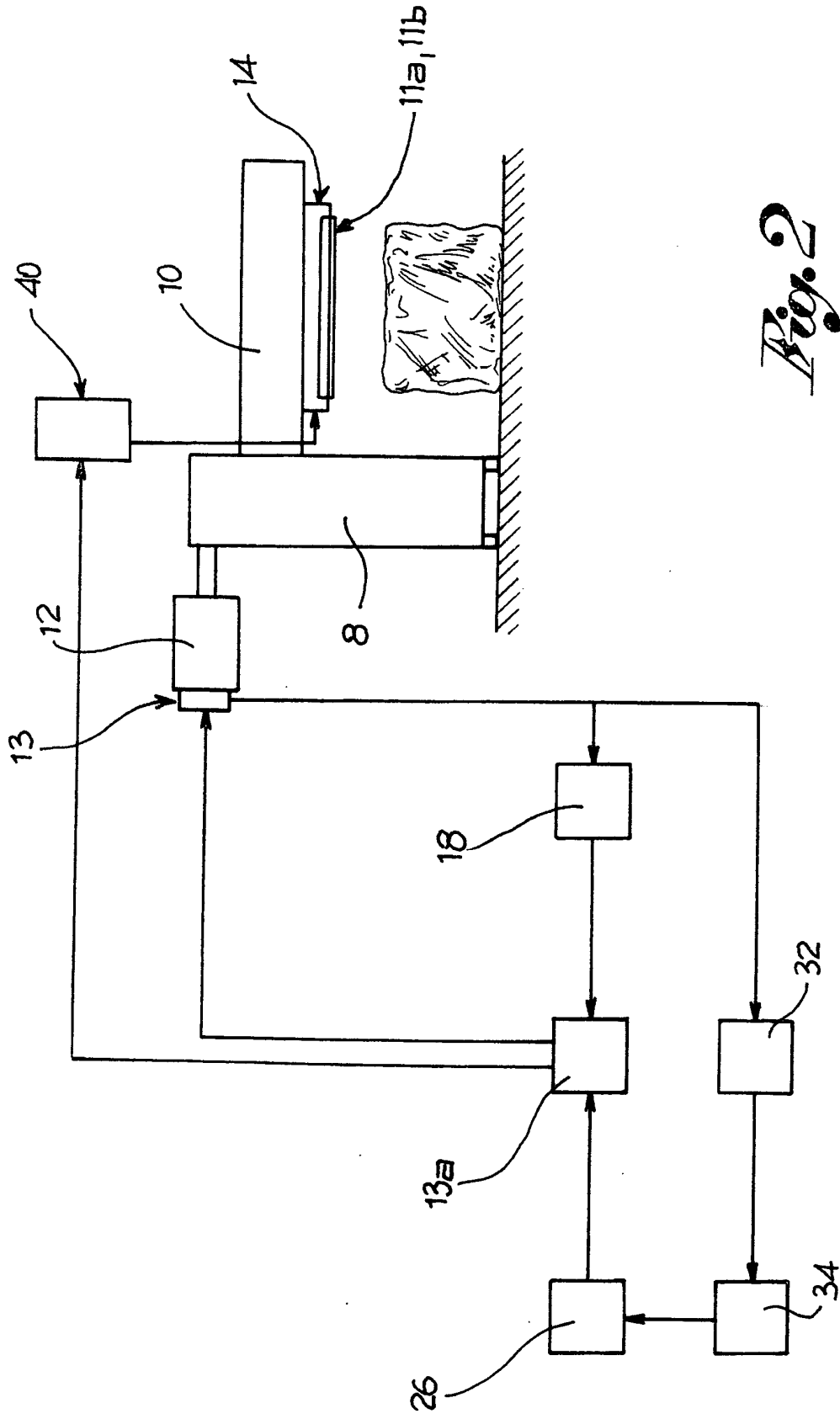

Fig. 2

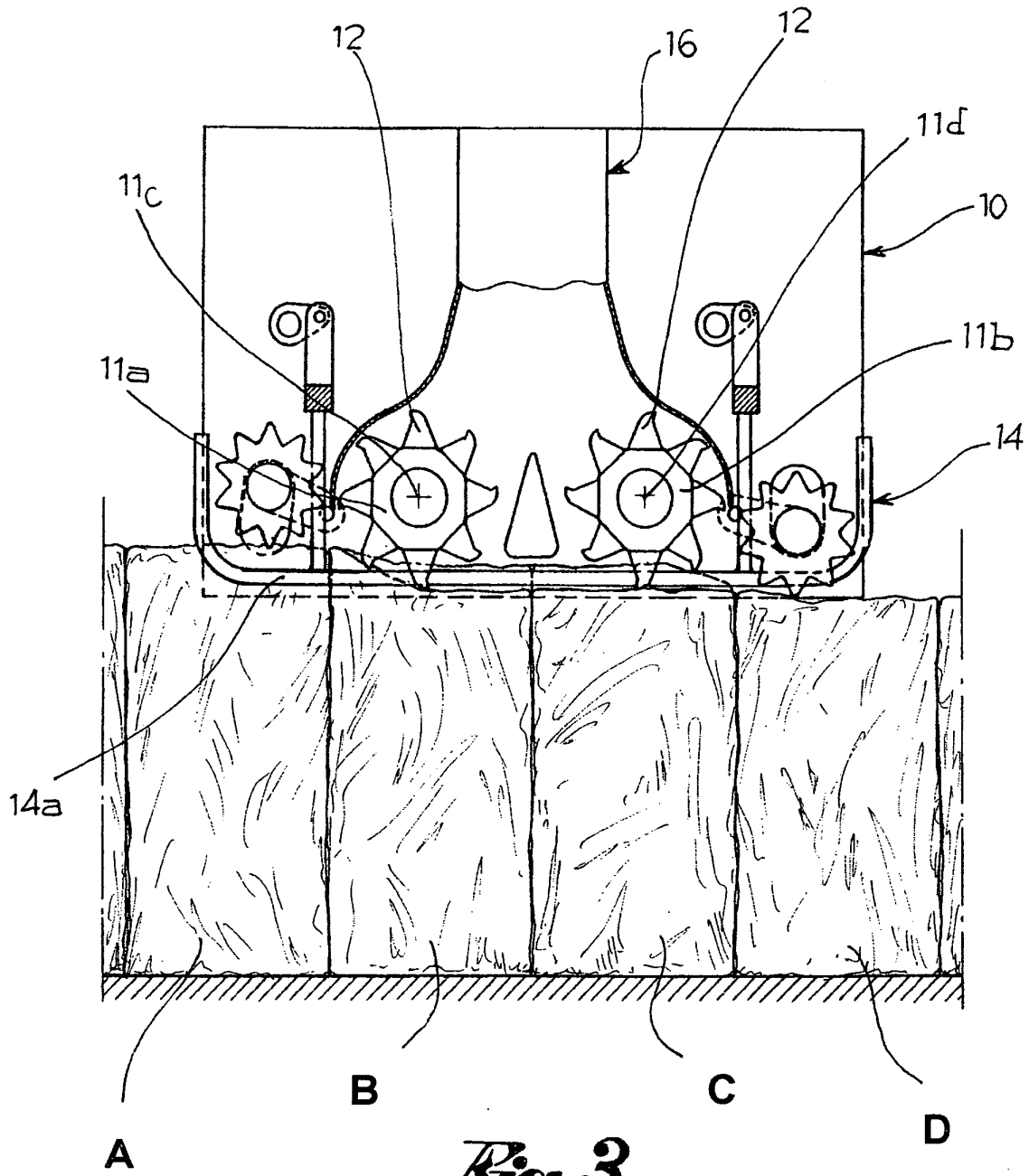

Fig. 3

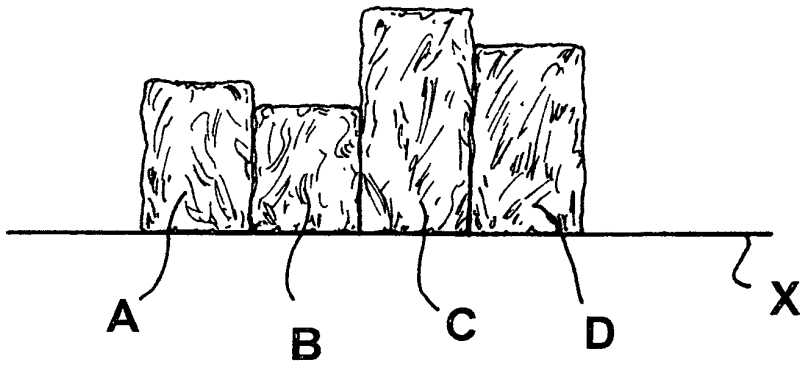

Fig. 4a

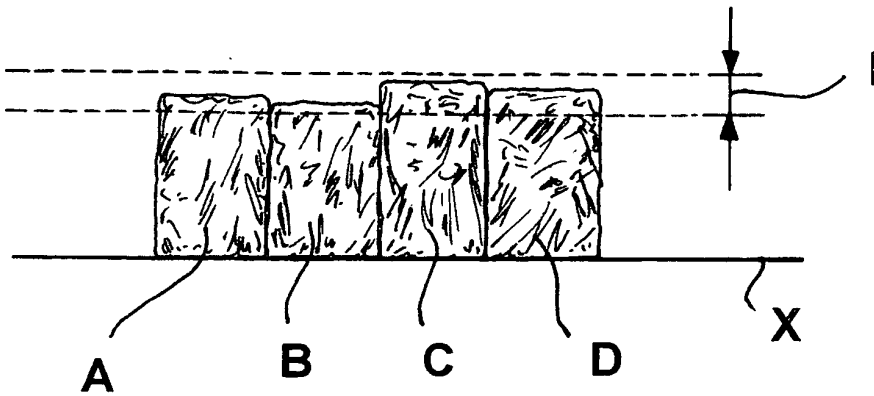

Fig. 4b

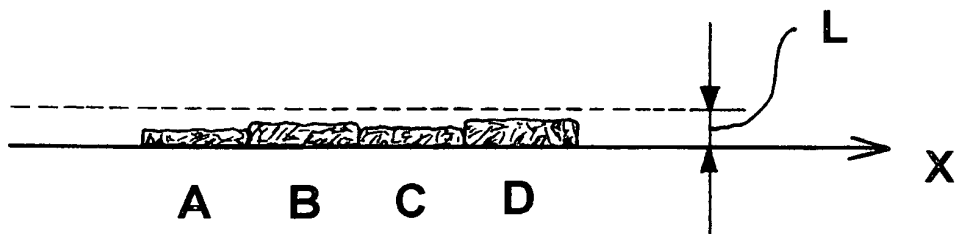

Fig. 4c

REFERENCES CITED IN THE DESCRIPTION

This list of references cited by the applicant is for the reader's convenience only. It does not form part of the European patent document. Even though great care has been taken in compiling the references, errors or omissions cannot be excluded and the EPO disclaims all liability in this regard.

Patent documents cited in the description

- EP 1571244 A1 [0007]