

(No Model.)

T. A. CLOUGH.  
MECHANICAL DYEING APPARATUS.

No. 459,744.

Patented Sept. 22, 1891.

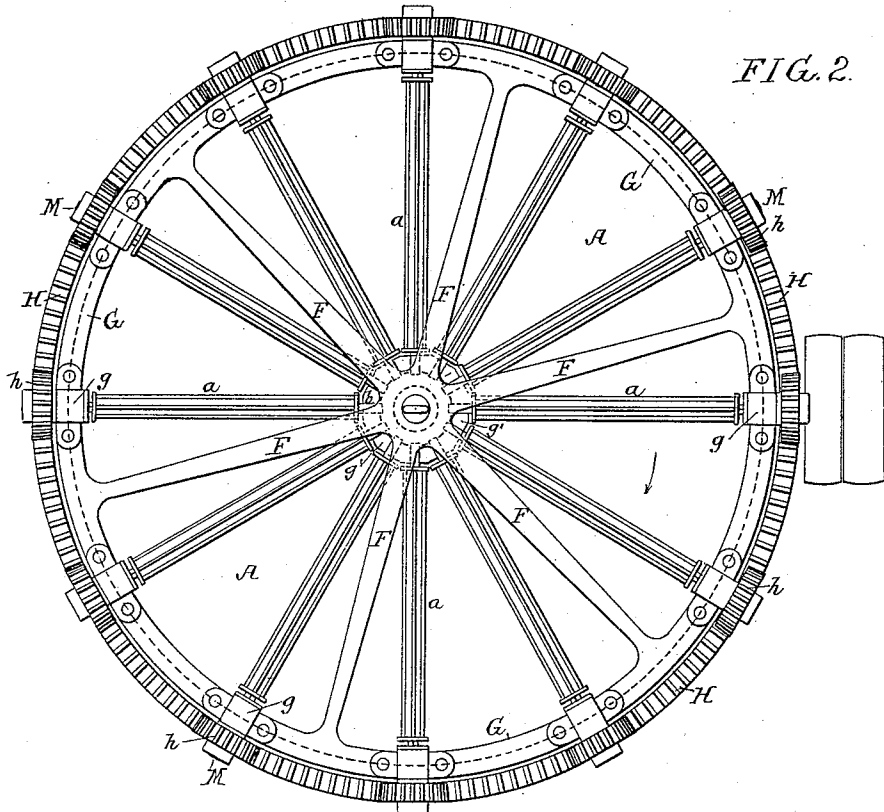

FIG. 2.

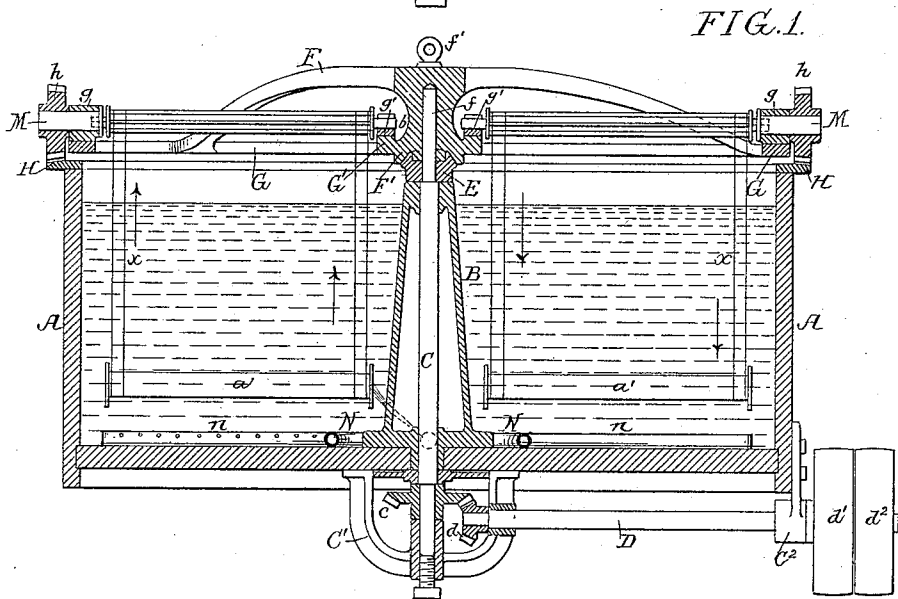

FIG. 1.

Witnesses:  
*Alex. Barkoff*  
*William D. Sawyer*

Inventor:  
*Thomas A. Clough*  
by his Attorneys  
*Hewson and Hewson*

# UNITED STATES PATENT OFFICE.

THOMAS A. CLOUGH, OF PHILADELPHIA, PENNSYLVANIA, ASSIGNOR OF  
ONE-HALF TO THOMAS J. BIGGER, OF SAME PLACE.

## MECHANICAL DYEING APPARATUS.

SPECIFICATION forming part of Letters Patent No. 459,744, dated September 22, 1891.

Application filed April 19, 1889. Serial No. 307,652. (No model.)

*To all whom it may concern:*

Be it known that I, THOMAS A. CLOUGH, a citizen of the United States, and a resident of Philadelphia, Pennsylvania, have invented certain Improvements in Mechanical Dyeing Apparatus, of which the following is a specification.

The object of my invention is to construct a machine for treating yarn in hank or skein for the purpose of dyeing, scouring, or bleaching the same. This object I attain in the following manner, reference being had to the accompanying drawings, in which—

Figure 1 is a sectional view of the improved machine, and Fig. 2 is a plan view of the same.

A is a vat or tank containing the dyeing, scouring, bleaching, or other liquid to be used, this tank being circular in form, and centrally situated in the tank is an upright bearing-block B, through which is passed a driving-shaft C. This shaft C is stepped in a bearing C', secured to the bottom of the tank, and on the shaft C is a bevel-wheel *c*, meshing with a bevel-pinion *d* on a shaft D, which has its bearings in brackets C' and C<sup>2</sup>. The shaft D is the driving-shaft of the machine, and is provided in the present instance with fast and loose pulleys *d'* *d*<sup>2</sup>. On the upper portion of the shaft C is a clutch-ring E, which rests directly upon the bearing B.

F is a yarn-carrying frame driven through the medium of the clutch E by the shaft C, said frame F having a clutch-face F', the teeth of which engage with the teeth of the clutch E, so that on driving the shaft C the frame F will be revolved. The frame F has a central orifice, into which projects the end *f* of the shaft C, which acts as a pivot for the frame.

On the top of the frame F is an eye *f'*, to which can be attached the hook of a pulley-block by which the frame can be raised, so that the yarn carried by the frame will be clear of the tank and can be removed and a duplicate of the frame inserted in position in the tank. On the outer ring G of the frame F is a series of bearing-blocks *g*, and on the inner disk G' of the frame is a series of bearing-blocks *g'*. Adapted to these bearings *g'* is a series of radial shafts *b*, carrying rollers *a*, on which the yarn to be dyed or other-

wise treated is hung. At its outer end each shaft *b* is squared and adapted to an opening in a drive-shaft M, adapted to the bearing *g*. A gear-wheel *h* on the shaft M meshes with an annular rack H on the edge of the tank A, so that as the frame F revolves the shaft M and hence the shafts *b* will also revolve in their bearings. The hanks of yarn *x* are suspended on the rollers *a*, carried by the shafts, and a loose roller *a'*, hung in the loop of the hank of yarn, is of sufficient weight to keep a tension on the yarn at all times, so that the yarn when the machine is in motion not only travels through the liquid in the direction of the arrow in Fig. 2, around the shaft C, but also has a vertical movement in the direction of the arrow, Fig. 1, and, if the level of liquid in the tank is as indicated by the lines in Fig. 1, two-thirds of the yarn will be in the liquid at all times and change will be rapid, so that I am enabled by this machine to more quickly dye or otherwise treat the yarn than heretofore and to produce more even shades in dyeing. The yarn is always in sight of the attendant, who has the machine directly under his control, and the frame and yarn, as soon as the yarn has been dyed sufficiently, can be quickly removed and another frame which has been loaded with yarn can be dropped in its place without loss of time.

In the bottom of the tank is a series of radial steam-pipes, which receive steam from an annular connecting-pipe N, and these radial pipes have orifices therein inclined backward—that is to say, in a direction opposite to the direction of movement of the yarn-carrying frame, so that the jets of steam issuing from the orifices of the pipes will tend to counteract any tendency which might otherwise exist to cause a current of the liquid in the tank in the direction of rotation of the yarn-carrying frame.

It will be evident that friction-gears may replace the rack and pinion gears for effecting the rotation of the shafts M.

I am aware that dyeing-machines have heretofore been constructed in which a rotating frame has been employed to carry the yarn around the circular tank; but in all of such constructions, so far as I am aware, the mech-

anism for rotating the independent yarn-carrying shafts has been placed at the inner ends of these shafts and a separate inner tub has been employed for such mechanism, the diameter of the tank being necessarily much greater than in the construction employed by me.

Having thus described my invention, I claim and desire to secure by Letters Patent—

1. A machine for dyeing or washing yarn, having in combination a tank A, a vertical bearing-post therein, a driving-shaft, a clutch E, secured thereon, a removable carrying-frame F, a clutch-face thereon adapted to engage with the clutch E, radiating yarn-carrying shafts, pinions thereon, bearings on said frame F for the inner and outer ends of said shafts, and a circular rack on the upper edge of the tank, with which said pinions are adapted to engage, substantially as specified.

2. The combination of the tank and the rotating yarn-carrying frame with steam-pipes

having openings located so as to discharge jets of steam into the liquor in the tank in a direction the reverse of the rotating movement of the yarn-frame, substantially as specified.

3. In a machine for dyeing or washing yarn, the combination of a tank, a circular rack on the upper edge of said tank, a rotatable frame, pinions *h*, mounted on stub-shafts, bearings *g* on the frame for said shafts, and radial yarn-carrying shafts *a*, having one end adapted to a squared orifice in said stub-shafts, the opposite ends of said shafts *a* being adapted to open-top bearing-blocks *g'*, substantially as specified.

In testimony whereof I have signed my name to this specification in the presence of two subscribing witnesses.

THOMAS A. CLOUGH.

Witnesses:

WILLIAM D. CONNER,  
HARRY SMITH.