

March 12, 1935.

J. H. GRAYSON

1,994,391

BURNER CONTROL

Filed Oct. 11, 1932

2 Sheets-Sheet 1

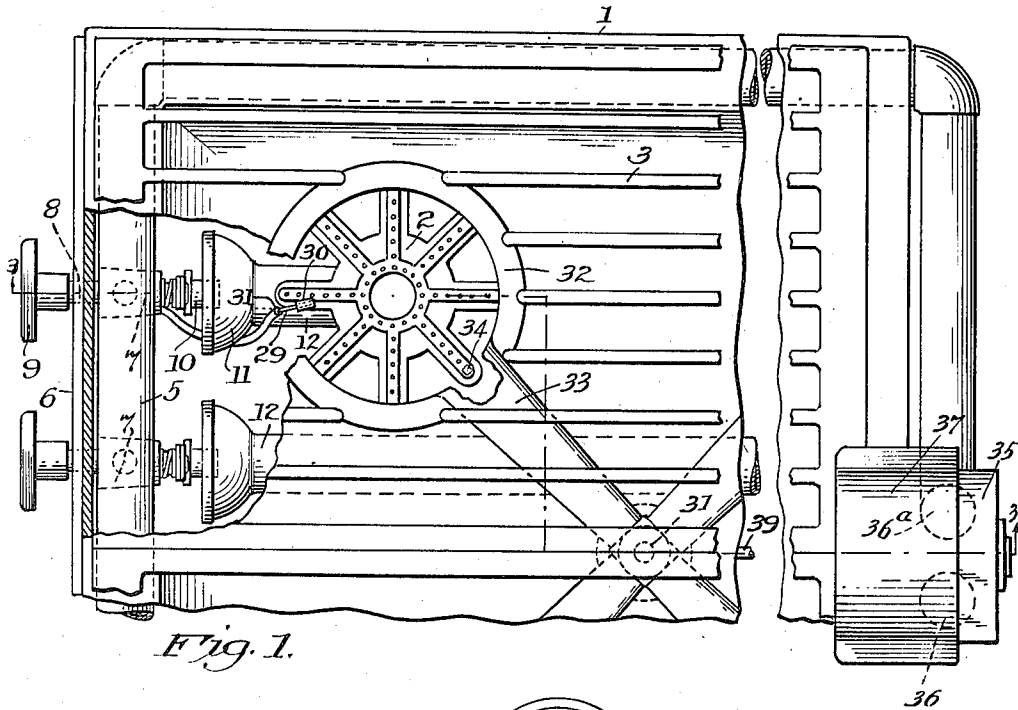

Fig. 1.

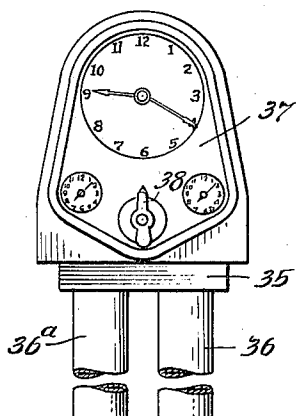
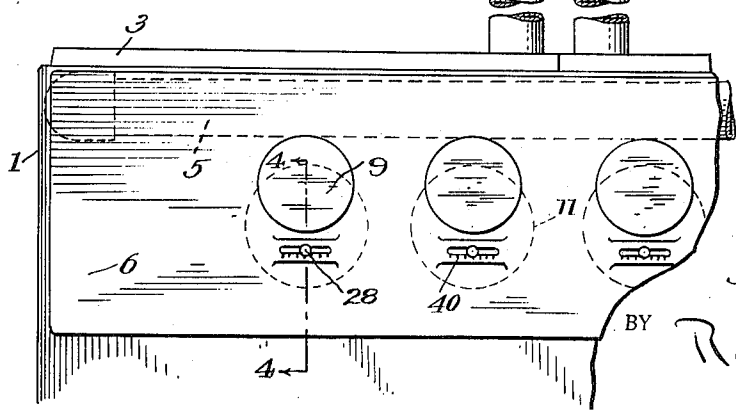

Fig. 2.



INVENTOR.  
*John H. Grayson,*

BY *R. W. Smith*

ATTORNEY.

March 12, 1935.

J. H. GRAYSON

1,994,391

BURNER CONTROL

Filed Oct. 11, 1932

2 Sheets-Sheet 2

Fig. 4.

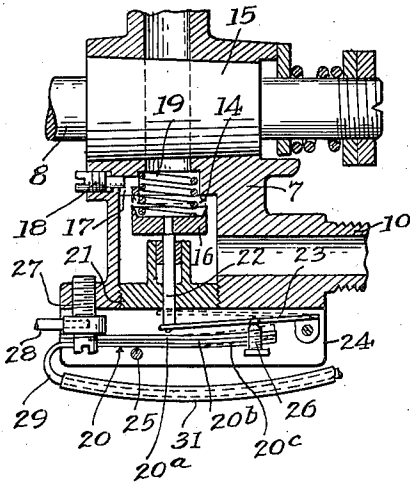

Fig. 5.

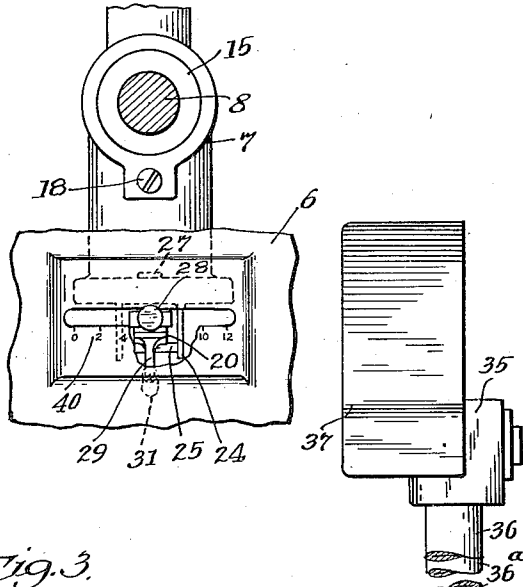

Fig. 3.

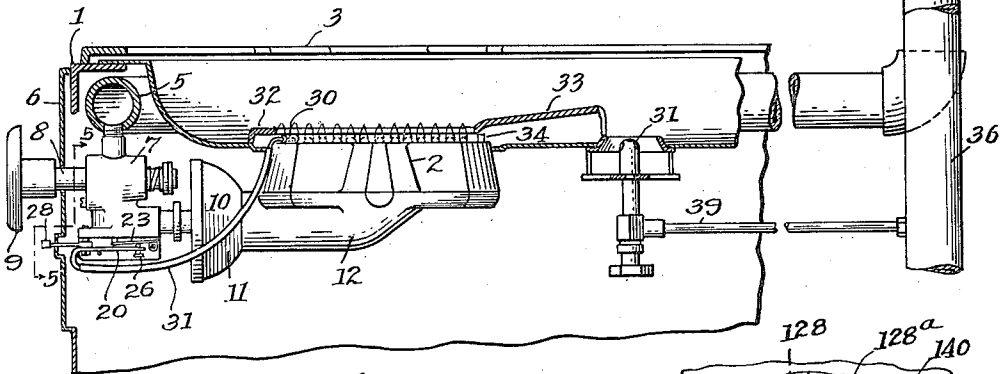

Fig. 6.

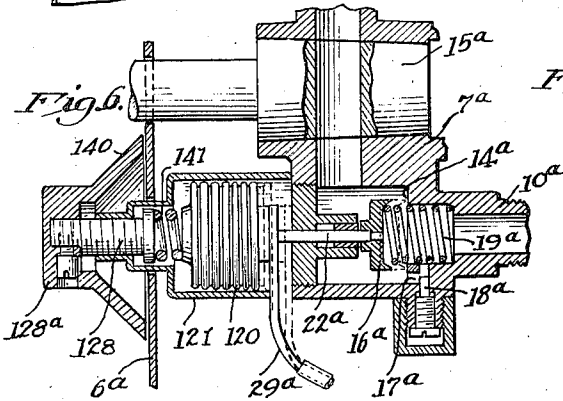
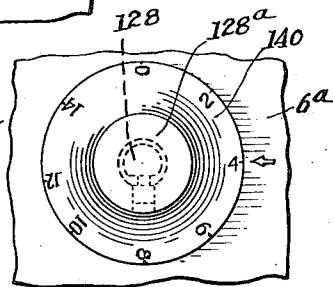

Fig. 7.



INVENTOR.

John H. Grayson,

BY

R. W. Smith

ATTORNEY.

# UNITED STATES PATENT OFFICE

1,994,391

## BURNER CONTROL

John H. Grayson, Lynwood, Calif., assignor to Grayson Heat Control, Ltd., Lynwood, Calif., a corporation of California

Application October 11, 1932, Serial No. 637,221

4 Claims. (Cl. 236—1)

This invention is a control for a top burner of a hot plate or cooking top, such as the cooking top of a gas range or the like; and has for its object to provide a practical and compact assembly whereby a top burner may be thermostatically controlled. Heretofore oven burners have been thermostatically controlled for regulating oven temperature; and the present invention provides thermostatic control for a top burner whereby the flame may be automatically turned down after predetermined burning at high flame, so that the lowered flame may continue the cooking without liability of burning or boiling over.

It is a further object of the invention to provide thermostatic control for a top burner which is automatically lighted at high flame when the gas is first turned on, so that after predetermined burning at high flame the burner may be automatically turned down. As a consequence cooking upon a top burner need not require constant attention, since after the burner has been lighted and has burned at high flame for a predetermined interval it may be automatically turned down to a low flame such as will just maintain the desired cooking temperature.

It is a still further object of the invention to provide thermostatic control for a top burner which is automatically lighted in accordance with predetermined setting of a time control, so that after the burner has been lighted and has burned at high flame for a predetermined interval, it may be automatically turned down for slowly continuing the cooking until the time control automatically extinguishes the flame at the end of a predetermined period.

It is a still further object of the invention to provide a thermostatic control which may be compactly assembled with relation to a usual top burner and its gas cock, so as to in no way obstruct use of the top burner nor provide an unsightly construction, and at the same time adapt the thermostatic control for reliable heat responsive actuation in accordance with the heat generated by the top burner.

It is a still further object of the invention to actuate the thermostatic control by heat conducted thereto from immediately adjacent the flame of the top burner, so that after burning for a predetermined interval, the heat generated by the initial high flame of the burner actuates the thermostatic control for reducing the flame, with the heat which is then conducted to the thermostatic control by the lowered flame maintaining the thermostatic control in its actuated posi-

tion so that the flame remains lowered for slowly continuing the cooking.

It is a still further object of the invention to adjust the thermostatic control so as to regulate the interval during which the burner remains at its initial high flame, and to also adjust the lowered flame to which the burner is automatically reduced after the predetermined interval.

Further objects of the invention will be readily understood from the following description of the accompanying drawings, in which:

Fig. 1 is a fragmentary plan view of the cooking top of a gas range.

Fig. 2 is a fragmentary front elevation of the cooking top.

Fig. 3 is a vertical section on the line 3—3 of Fig. 2.

Fig. 4 is an enlarged vertical section on the line 4—4 of Fig. 1.

Fig. 5 is an enlarged transverse section on the line 5—5 of Fig. 3.

Fig. 6 is a view similar to Fig. 4, showing a modified construction.

Fig. 7 is a front elevation of the modified construction shown in Fig. 6.

The invention is applicable to top burners of hot plates or cooking tops, and is illustrated in connection with the top burner of a cooking top for a gas range. A portion of the usual frame of the cooking top is shown at 1, and one of what is preferably a plurality of top burners carried by the frame, is shown at 2. The burner directs its flame upwardly through a usual open grid 4 of the cooking top so as to heat any usual cooking vessel placed on the grid; and the burner is supplied with fuel from a gas manifold 5 extending across the front of the upper portion of frame 1 and preferably concealed by a front plate 6. A gas cock 7 for the burner communicates with the manifold and preferably depends therefrom and may be concealed within the frame 1 by the plate 6, with the stem 8 of the gas cock projecting outwardly through the plate 6 and provided at its outer end with a usual control head 9. A gas nipple 10 projects rearwardly from the casing of the gas cock and extends into a usual gas and air mixing chamber 11 which communicates with a fuel pipe 12 leading to the burner 2.

It will be understood that a plurality of burners may be supported by frame 1 in accordance with usual assembly, with gas cocks 7 spaced along the manifold 5 and having fuel pipes 12 leading to the respective burners; but since the burners and their associated parts are of simi-

lar construction only one unit of the complete assembly is illustrated in the drawings.

The burner 2 is thermostatically controlled so as to automatically lower its flame after initially burning at high flame for a predetermined interval, but since the burner is a top burner for a cooking top and thus directs its flame into a relatively open space rather than into an enclosure such as an oven, the thermostatic control is actuated not when a predetermined temperature is obtained in an enclosed space, but when a predetermined amount of heat has been generated by the flame of the burner. For this purpose heat from immediately adjacent the flame of the burner is conducted to the thermostatic control for actuating the same; and in order to provide a simple and compact construction the thermostatic control is preferably adjacent the gas cock 7 which is appreciably spaced from the burner, and a heat conductor leads from the burner flame to the thermostatic control, the assembly being such as to insure uniform conduction of heat but in no way interfere with use of the burner.

As an instance of this arrangement the thermostatic control and the gas cock 7 may form a unitary assembly, with the thermostatic control below the gas cock. This construction is shown in detail in Fig. 4. The bore of the gas cock forms a valve seat 14 at one side of its usual conical plug 15 and at that end of the bore which communicates with nipple 10, remote from the intake end of the bore which communicates with manifold 5 at the opposite side of plug 15. A valve 16 cooperates with seat 14 for closing the bore of the gas cock, and a by-pass 17 around this cooperating valve and seat maintains restricted communication through the bore of the gas cock when valve 16 is closed. Means are preferably provided for adjusting flow through the by-pass, and said means may comprise a plug 18 adapted for threaded adjusted projection into the bore of the by-pass.

The valve 16 is normally in open position, preferably under the tension of a spring 19, and is closed by a thermostatic member 20 which may be mounted below a head 21 at the bottom of the casing of the gas cock. An operating connection is preferably provided between the thermostatic member and the stem 22 of the valve 16 which projects through head 21, whereby the valve may be readily shifted to closed position against the tension of its spring, by relatively slight movement of the thermostatic member.

The operating connection is shown as a lever 23 pivoted in a guide 24 which depends from head 21, with the swinging end of the lever connected to the valve stem 22. The thermostatic member is preferably a tri-metallic strip comprising metals 20<sup>a</sup>, 20<sup>b</sup>, and 20<sup>c</sup>, the metals 20<sup>a</sup> and 20<sup>b</sup> having different coefficients of expansion, and the metal 20<sup>c</sup> being of heat conducting material. The strip 20 may be fulcrumed intermediate of its ends on a pin 25 carried by the guide 24, with a set screw 26 in one end of the thermostatic strip adapted to engage the lever 23; and the opposite end of the strip is adapted for adjustment so as to rock the strip on its fulcrum. This adjustment may be by means of a pin 27 extending through and abutting against the upper side of the thermostatic strip and threaded into the head 21 for longitudinal adjustment; and threaded adjustment of the pin may be by means of an operating lever 28 projecting outwardly through the front plate 6,

whereby the lever is adapted for convenient manual control.

Heat is conducted to strip 20 from the flame of burner 2, preferably by a heat conductor 29 fixed to that end of the strip 20 which is engaged by the pin 27 and extending around the fuel pipe 12 and thence into the space between adjacent rows of the fuel openings of burner 2, with the tip of the heat conductor just above the burner so as to extend directly into the flame. The tip of the conductor may be protected by a metallic sleeve 30, and in order to prevent heat radiation from the conductor it is preferably heat insulated throughout the major portion of its length as shown at 31.

When the gas is turned off, thereby extinguishing the flame of burner 2 so that no heat is conducted to the thermostatic strip 20, the latter is straightened out since there is no expansion differential between the metals 20<sup>a</sup> and 20<sup>b</sup>, and the lever 23 is thus free to swing downwardly as shown in Fig. 4, so that the valve 16 is opened by its spring 19. When the gas is turned on, it flows past the open valve 16 and thence to the burner 2 which is lighted at high flame; and heat from the flame is conducted to the strip 20<sup>c</sup> which distributes the heat to the strips 20<sup>a</sup> and 20<sup>b</sup> having different coefficients of expansion, thereby bowing the thermostatic strip so that its set screw 26 swings the lever 23 upwardly for closing the valve 16 as shown by broken lines in Fig. 4. The fuel supply is thus shut off, except for the restricted flow through by-pass 17 which maintains the burner at low flame as shown by broken lines in Fig. 4.

The burner 2 may be automatically lighted when the fuel is first turned on, as for example by an automatic lighter of the flash type. Such a lighter may include a pilot 31 positioned as shown in Fig. 1, convenient to all of the plurality of burners with which the cooking top may be equipped. Burner 2 has a flame chamber 32 surrounding the same and communicating with a duct 33, and the ducts 33 of the respective burners lead to the pilot 31 as shown in Fig. 1. The burner 2 has a fuel outlet 34 which discharges gas into its duct 33, and the fuel accumulating in the duct when the gas is first turned on, is thus ignited by the pilot so that the flame flashes back into chamber 32 for lighting the burner.

The burner control as thus described may be employed in connection with usual manual control of gas cock 7, but is also advantageously employed in connection with automatic time controlled cooking. Time control may be by means of a valve 35 between the fuel supply pipe 36 and a pipe 36<sup>a</sup> which leads to the manifold 5, with the valve 35 automatically opened and subsequently closed in accordance with the setting of a clock mechanism 37 which may be provided with a control 38 for rendering the time control operative or inoperative. The fuel pipe 39 for pilot 31 communicates with supply pipe 36 so that gas is supplied to the pilot at all times, irrespective of the position of the valve 35 of the time control mechanism, while the gas supply from pipe 36<sup>a</sup> to the manifold 5 is controlled by valve 35, so that with the time control in operation it starts and stops the flow of gas to whichever of the burners 2 has previously had its gas cock 7 manually opened.

In operation, assuming that the gas range is not equipped for time controlled cooking, or that use of time control is not desired and has been rendered inoperative by turning the control 38, 75

fuel is then supplied by pipe 36, past the open valve 35, to the manifold 5. The gas cock 7 of the burner which is to be used is manually turned on by means of its control head 9, so that gas

flows past the open valve 16 of the gas cock and thence to the burner, and the burner may be lighted by the automatic flash lighter when the latter is a part of the equipment.

In order to insure operation of an automatic flash lighter, and for the purpose of quickly raising the cooking substance to the desired temperature, it is desirable that the control 9 be first turned on full so as to produce a high flame; and after a few minutes, and when the desired cooking temperature has been obtained, it is expedient that the flame be lowered for slowly continuing the cooking. This is done automatically by the thermostatic control, thereby avoiding the necessity of constant attention by the cook, and also avoiding the possibility of boiling over or burning in the event of the cook forgetting to lower the flame at the proper time. The interval during which the burner is to remain at high flame is predetermined by adjusting the lever 28, which may have scale markings 40 associated therewith and calibrated in minutes. Shifting the lever in the direction to reduce the time interval indicated by the scale 40, screws the pin 27 downwardly so as to rock the strip 20 on its fulcrum 25 and thereby elevate the end of the strip which carries the set screw 26, and heat conducted to the strip thereby bows the same for closing valve 16 when the strip has acquired a corresponding relatively small amount of heat. Shifting the lever 28 in the opposite direction so as to increase the time interval indicated by the scale 40, screws the pin 27 upwardly so that strip 20 may rock on its fulcrum for depressing its end which carries set screw 26, and a corresponding greater amount of heat must therefore be acquired by the thermostatic strip in order to bow it to an extent which will close the valve 16.

It will thus be seen that no attention on the part of the cook and after an interval of burning at high flame, as predetermined by the adjustment of lever 28, the valve 16 is automatically closed, so that continued flow of gas to the burner is via the by-pass 17, thereby reducing the burner to a low flame which may be regulated by predetermined adjustment of plug 18. The plug 18 is preferably adjusted so as to maintain a low flame which will avoid accidental extinguishing of the burner, and which will produce just sufficient heat to slowly continue the cooking and maintain the temperature to which the strip 20 has been previously raised by the high flame, so as to maintain the bowed position of the strip and thereby hold the valve 16 in closed position.

If time controlled cooking is desired, the control 38 is turned so as to render the time control operative, and the clock mechanism 37 is set so as to open valve 35 at a predetermined time and then reclose the valve after a predetermined period. At the same time the gas cock 7 of the burner which is to be used is turned on full. The valve 35 remains closed and thus shuts off the fuel supply to manifold 5 until the valve is automatically opened in accordance with the predetermined setting of the time control, whereupon fuel is supplied to manifold 5 and thence to the open gas cock of the previously selected burner. The gas thus flows past the open valve 16 of the gas cock and thence to the burner for automatic lighting by the pilot 31, with the flow of gas which

results from the cock 7 having been turned on full, insuring operation of the automatic flash lighter. A high flame is thus produced, and after an interval of burning at high flame and in accordance with predetermined adjustment of lever 28, the thermostatic strip 20 is actuated as previously described so as to close valve 16 for restricted flow of gas through by-pass 17, thereby reducing and then maintaining a low flame for slowly continuing the cooking.

The invention is thus particularly applicable to time controlled cooking on a top burner having an automatic flash lighter, since in order to insure proper operation of a flash lighter the gas must first be turned on full, but cooking on a top burner cannot be continued indefinitely at full flame; and the thermostatic control provides practical means for lowering the flame after a predetermined interval so as to avoid burning or boiling over, whereby time controlled cooking may be fully automatic.

The invention is also particularly advantageous when heavy aluminum cooking vessels or so called waterless cookers are used on a top burner, since after having been initially heated to the required temperature, such utensils demand a minimum flame for continuing the cooking very slowly, and the thermostatic control provides the desired initial high flame and the subsequent minimum flame, for first heating such utensils to the desired temperature and then slowly continuing the cooking at reduced temperature.

The thermostatic control as thus described is adapted for compact assembly with relation to a usual manually controlled gas cock, with the unitary arrangement of gas cock 7 and control valve 16 insuring a simple and economical construction, and the heat conductor 29 providing for accurate operation of the thermostatic control by a top burner, the flame of which is directed into the open space above the burner; but it will be apparent that the thermostatic member and its operating connection are subject to modification while still maintaining these advantages of compact assembly and positive actuation.

For example the modified construction shown in Figs. 6 and 7 may be employed, wherein the control valve is actuated by a thermostatically expansible bellows to which heat is conducted from the open flame of the burner. As an instance of this arrangement the gas cock 7<sup>a</sup> has the usual rotatable conical plug 15<sup>a</sup>, and the bore of the gas cock forms a valve seat 14<sup>a</sup> adjacent the gas discharge nipple 10<sup>a</sup>, with the valve seat 14<sup>a</sup> adapted for engagement by valve 16<sup>a</sup> having its stem 22<sup>a</sup> projecting outwardly from the front of the gas cock casing. A by-pass 17<sup>a</sup> extends around the valve seat 14<sup>a</sup> and is regulated by a plug 18<sup>a</sup> as previously described, and a spring 19<sup>a</sup> normally opens the valve 16<sup>a</sup> against the action of the thermostatic member.

The thermostatic member is preferably mounted in a housing 121 which projects forwardly from the gas cock casing through the front plate 6<sup>a</sup>, and heat conductor 29<sup>a</sup> which extends to the flame of the burner as previously described, conducts heat to a bellows 120 which is mounted in housing 121. The bellows contains an expansible fluid and is operatively connected to valve stem 22<sup>a</sup>, preferably by the end of conductor 29<sup>a</sup> projecting between and being fixed to the proximate ends of the valve stem and the bellows so that heat conducted to the bellows expands the fluid contained therein and thereby expands the bellows for shifting the valve stem 22<sup>a</sup> so as to close

valve 16<sup>a</sup> after a predetermined interval, as shown by broken lines in Fig. 6.

The bellows is adapted for longitudinal adjustment in housing 121 for regulating the interval of time before the valve 16<sup>a</sup> is closed, and for this purpose a rod 123 may engage that end of the bellows which is remote from valve stem 22<sup>a</sup>, and is threaded through the housing 121, with an operating head 128<sup>a</sup> fixed on the projecting end of the rod at the front of plate 6<sup>a</sup>. The head 128<sup>a</sup> has a dial 140 preferably calibrated in minutes, whereby manual rotary adjustment of the operating head longitudinally adjusts the rod 128 and thereby correspondingly shifts the bellows in its housing so that expansion of the bellows closes the valve 16<sup>a</sup> after an interval of time determined by the calibrations of the dial.

The engagement of rod 128 with the end of the bellows is preferably arranged to permit yielding of the bellows after valve 16<sup>a</sup> is closed, so that any further expansion of the bellows will not exert undue pressure on the closed valve; and for this purpose a spring 141 is preferably interposed between the end of the bellows and the end of rod 128, and normally maintains its expanded position so that longitudinal movement of rod 128 is transmitted to the bellows for correspondingly shifting the bellows in its housing, but after the bellows has expanded and has closed valve 16<sup>a</sup> the spring 141 is adapted to yield responsive to increased pressure resulting from further expansion of the bellows, so that the heat conducted to the bellows maintains its expanded position for holding the valve 16<sup>a</sup> closed, but without exerting undue pressure against the valve.

After a predetermined interval of burning at high flame, the thermostatically controlled valve is thus adapted to shut-off the gas supply except for that which flows through by-pass 17<sup>a</sup>, so as to automatically lower and then maintain the reduced flame throughout the remainder of the cooking period.

I claim:

1. In combination, a cooking top, a burner for the cooking top directing its flame into the open space above the cooking top, means for supplying

fuel to the burner so as to produce a high flame, a thermostatic control for restricting the fuel supply so as to lower the flame, and means for conducting heat from immediately adjacent the flame of the burner to the thermostatic control. 5

2. In combination, a cooking top, a burner for the cooking top directing its flame into the open space above the cooking top, means for supplying fuel to the burner so as to produce a high flame, a thermostatic control adapted for actuation for restricting the fuel supply and thereby lowering the flame after an interval of burning at high flame, and means for conducting heat from the flame of the burner for actuating the thermostatic control. 10 15

3. In combination, a gas range having a cooking top, a gas manifold for the cooking top, a manually regulated gas cock communicating with the manifold, a burner for the cooking top, a fuel pipe leading from the outlet end of the gas cock to the burner, a normally open valve in the outlet end of the gas cock, a by-pass around the valve, a thermostatic member adapted for actuation to close the valve, and a heat conductor connected to the thermostatic member and extending to the burner with the tip of the conductor in the flame of the burner, the heat conductor being adapted to conduct heat from the flame of the burner to the thermostatic member so as to actuate the latter after predetermined burning at high flame and thereby close the valve for restricting the fuel supply to flow through the by-pass for reducing the flame, and the heat conductor being adapted to conduct heat from the lowered flame to the thermostatic member so as to maintain the latter in actuated position for retaining the valve in closed position. 20 25 30 35

4. In combination, a gas range having a cooking top, a gas manifold for the cooking top, a burner for the cooking top, a fuel pipe leading from the manifold to the burner, a thermostatic member adapted for actuation to restrict but maintain reduced flow of fuel through said pipe, and a heat conductor extending from the burner to the thermostatic member. 40 45

JOHN H. GRAYSON.