

J. C. LODOR.
LOCK.

APPLICATION FILED AUG. 4, 1910.

1,000,098.

Patented Aug. 8, 1911.

2 SHEETS-SHEET 1.

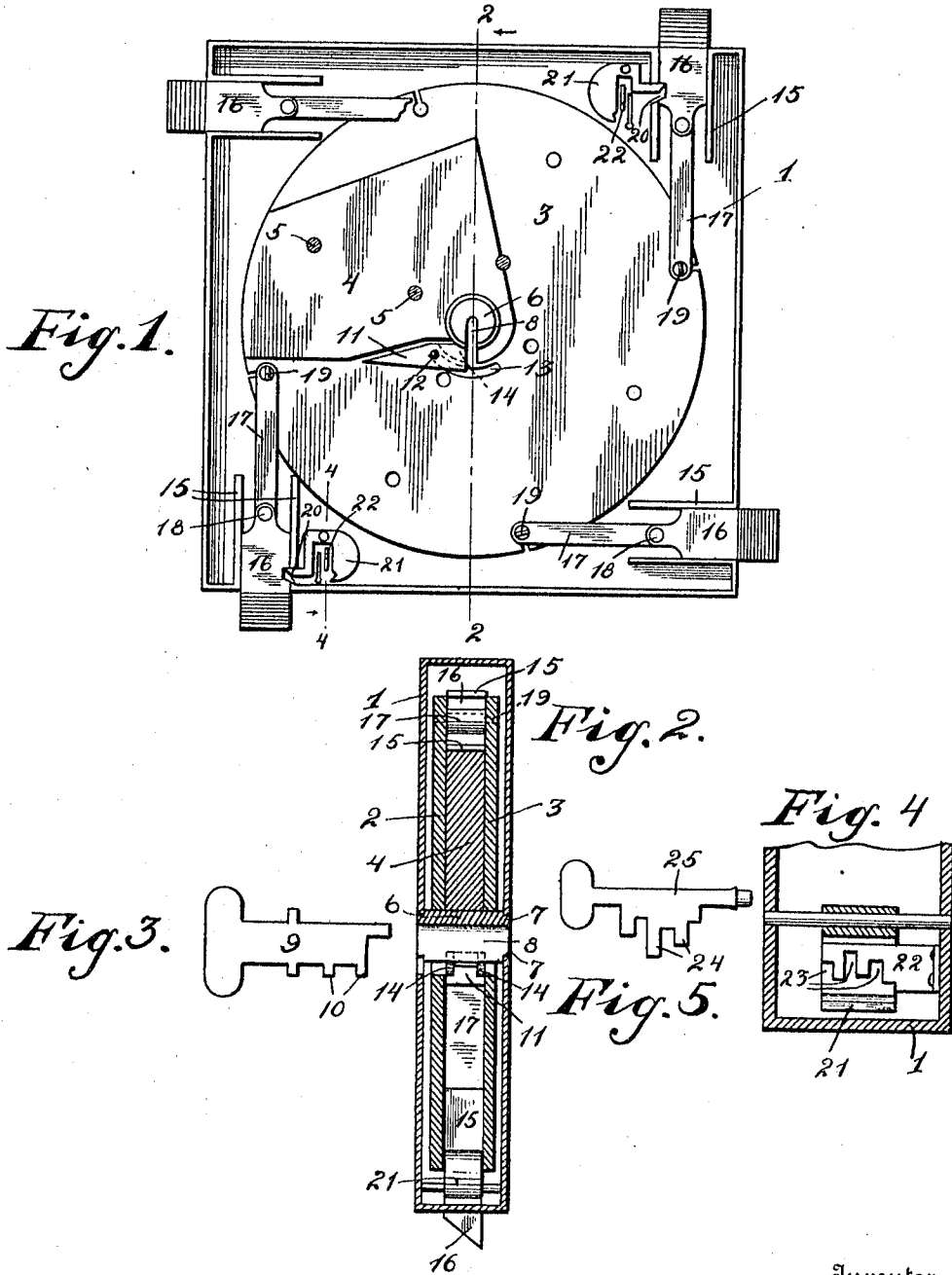

Witnesses

J. Milton Lester
B. Fishburne

By

Inventor
James C. Lodor.

C. L. Parker
Attorney

J. C. LODOR.

LOCK.

APPLICATION FILED AUG. 4, 1910.

1,000,098.

Patented Aug. 8, 1911.

2 SHEETS—SHEET 2.

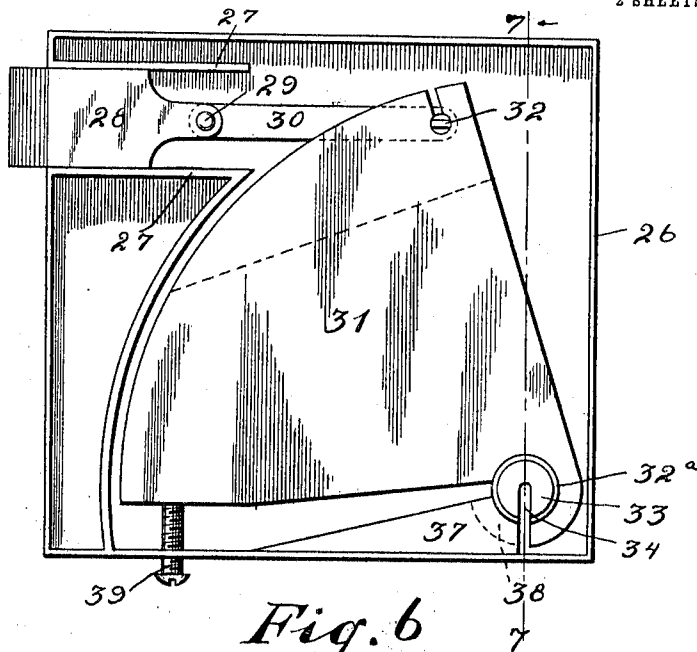

Fig. 6

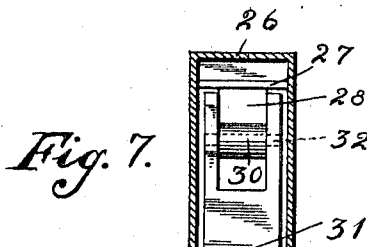

Fig. 7.

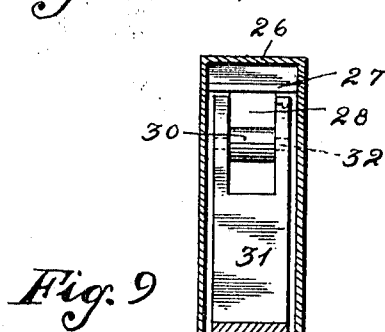

Fig. 9

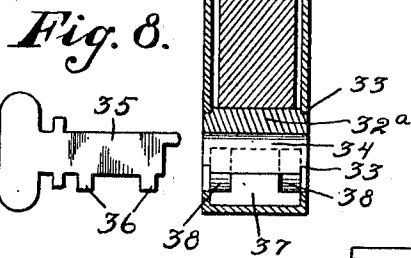

Fig. 8.

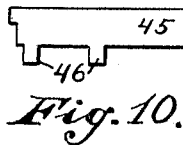
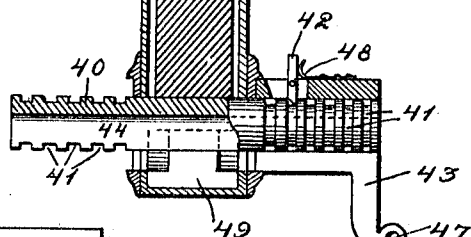

Fig. 10.

Inventor

James C. Lodor

Witnesses

J. Milton Lester
W. H. Johnson

384

C. L. Parker,
Attorney

UNITED STATES PATENT OFFICE.

JAMES C. LODOR, OF WILMINGTON, NORTH CAROLINA.

LOCK.

1,000,098.

Specification of Letters Patent.

Patented Aug. 8, 1911.

Application filed August 4, 1910. Serial No. 575,440.

To all whom it may concern:

Be it known that I, JAMES C. LODOR, a citizen of the United States, residing at Wilmington, in the county of New Hanover and State of North Carolina, have invented certain new and useful Improvements in Locks, of which the following is a specification.

My invention relates to locks and particularly to locks of the gravity type.

An important object of this invention is to provide a gravity lock, which is formed of few and simple parts, and which parts cannot be actuated by an improper key.

Other objects and advantages of my invention will be apparent in the course of the following description.

In the accompanying drawings, forming a part of this specification, and in which like numerals are employed to designate like parts throughout the same, Figure 1 is a side view of my lock, one side of the casing being removed, Fig. 2 is a vertical cross-sectional view taken on line 2—2 of Fig. 1, Fig. 3 is a side view of the key for moving the tumbler, Fig. 4 is an enlarged detail sectional view through the locking mechanism for the bolts, taken on line 4—4 of Fig. 1, Fig. 5 is a side view of the key to cooperate with said locking mechanism, Fig. 6 is a side view of a modified form of lock and showing one side of the casing removed, Fig. 7 is a vertical cross-sectional view taken on line 7—7 of Fig. 6, Fig. 8 is a side view of a key to cooperate with the form of lock shown in Figs. 6 and 7, Fig. 9 is a view similar to Fig. 7, and showing the lock provided with an extended spindle for carrying a handle, and Fig. 10 is a side view of a key to be used in connection with the form of lock shown in Fig. 9.

The form of lock shown in Figs. 1 to 5, inclusive, is particularly well adapted for use upon safety deposit boxes or vaults. This lock comprises a preferably rectangular casing 1, within which are mounted spaced disks 2 and 3. Disposed between these disks and eccentrically arranged with relation to the same is a tumbler or weight 4 having rigid connection with said disks by means of pins 5 or the like. The disks 2 and 3 are pivotally mounted upon a spindle 6 having reduced ends 7, which are rotatably mounted within suitable openings formed through the sides of the casing 1. This spindle is provided with an axial open-

ing 8 for receiving a suitable key 9 carrying teeth 10. A ward 11 is disposed near the spindle 6, as shown in Fig. 1 and has rigid connection with the casing 1 by means of a pin 12, which is disposed within a curved slot 13 formed through the disk 3. This ward is stationary with relation to the casing 1 and is provided with suitable curved openings or slots 14. From the construction of the above referred to parts, it is obvious that the key 9 may be inserted within the spindle 6 and rotated so that its teeth 10 engage the tumbler 4 to oscillate the same. If a key is employed having teeth not arranged in the same manner as the teeth on the key 9, such key cannot be rotated past the ward 11 and therefore could not actuate the tumbler. It is to be understood that the form of key shown in Fig. 3 may be altered, provided that the ward 11 is correspondingly altered to cooperate therewith.

The casing 1 is provided near its corners with tracks or guides 15 between which are slidably mounted bolts 16. As shown in Fig. 1, there are four of these bolts, which have their inner ends pivotally connected with arms 17, as shown at 18, said arms having their inner ends disposed between and pivotally connected with the disks 2 and 3, as shown at 19. Certain of the bolts 16 are provided with cut-out portions 20 for receiving the free end of a pivoted tumbler or weight 21. Each of the weights 21 has a ward 22 arranged near the same, as shown, having suitable openings 23 formed there-through to receive teeth 24 of a key 25. These tumblers 21, together with their wards and keys, constitute locking mechanism for the bolts 16. I wish it understood that I may equip one or all of the bolts with the locking mechanism above referred to, and that the locking mechanism for each bolt may preferably employ a different key. It will thus be seen that if the four bolts were provided with locking mechanisms, and each mechanism was unlocked by a different key, counting the key to actuate the tumbler 4, it would take five different keys to actuate the lock so that the door to which the same is secured could be opened.

In the form of lock as shown in Figs. 6 to 8, inclusive, a preferably rectangular casing 26 is provided, having tracks or guides between which is slidably mounted a bolt 27. This bolt has pivotal connection, as

shown at 29, with an arm 30, the inner end of which is pivotally connected with a tumbler or weight 31, as shown at 32. This tumbler 31 is preferably triangular and is pivotally mounted upon a spindle 32^a, having reduced cylindrical ends 33 which are rotatably mounted within suitable openings formed through the sides of the casing 26. The spindle 32^a is provided with an axial opening 34 for receiving a key 35 having teeth 36. Arranged near and below the spindle 32^a is a stationary ward 37 which is rigidly connected with the casing 26. This ward is provided with openings or grooves 38 to allow of the passage of the teeth 36, whereby said teeth may engage the tumbler 31 for oscillating the same. It is obvious that the ward 37 will prevent the use of an improper key. The downward movement of the tumbler 31 and accordingly the outward throw of the bolt 28, may be regulated by the proper manipulation of a screw 39 tapped through the casing 26.

The lock shown in Fig. 9 is of the same construction as that shown in Figs. 6 and 7, except that the spindle 32^a is dispensed with and the tumbler 31 is pivotally mounted upon a long spindle 40 which extends outwardly of the casing 26, as shown. This spindle is rotatably mounted within openings formed through the casing 26. This spindle 40 is provided near its ends with a plurality of annular grooves 41 to receive a pawl 42 carried upon the tubular body portion of a handle 43. The spindle 40 is provided with an axial opening 44 for receiving a key 45 having teeth 46. The handle 43 is also provided with a suitable opening for the reception of the key 45. The key 45 is adapted to fit snugly within the handle 43 and be held therein by a pin (not shown) which is to be inserted through the opening 47. The pawl 42 is held in its proper position by a spring 48 suitably secured to the tubular body portion of the handle 43. Although I have shown only one handle arranged upon the spindle 40, it is to be understood that a corresponding handle should be arranged upon each end of the same. A ward 49 is disposed near the spindle 40 for cooperation with the key 45 to prevent the employment of an improper key.

In the operation of the lock shown in Figs. 1 to 5 inclusive, each of the bolts 16 are first released so that they are free to move, and then the disks 2 and 3 are rotated by the key 9. This rotation of the disk draws the bolts 16 within the casing 1. It is obvious that when the key 9 is released the tumbler 4 will return the bolts 16 to their outer positions.

It is thought that the operation of the lock disclosed in Figs. 6 to 10 inclusive is obvious, and such operation will not be stated.

I wish it understood that the form of my

invention herewith shown and described is to be taken as a preferred example of the same, and that certain changes in the shape, size and arrangement of parts may be resorted to without departing from the spirit of my invention or the scope of the subjoined claims.

Having fully described my invention, I claim:—

1. In a lock of the character described, a casing, a spindle pivotally mounted within said casing, a tumbler pivotally mounted upon said spindle, a bolt having slidable engagement with the casing, means connecting said tumbler and bolt, said spindle being provided with an axial opening, and a key for insertion within said axial opening, having a portion extending beyond the periphery of the spindle to engage the tumbler for effecting a movement of the same.

2. In a lock of the character described, a casing, a spindle rotatably mounted within said casing, a tumbler pivotally mounted upon said spindle, a sliding bolt, an arm pivotally connected with said sliding bolt and tumbler, said spindle being provided with an axial opening for receiving a key, said key being adapted to lock said spindle and tumbler together whereby the latter may be moved upon the rotation of the former by said key and a ward disposed near said spindle to prevent the employment of an improper key, said ward and key being so constructed that a portion of the key passes through said ward.

3. In a lock of the character described, a casing, a spindle rotatably mounted within the same, a tumbler pivotally mounted upon said spindle, a sliding bolt, connecting means between said tumbler and sliding bolt, means to lock said sliding bolt independently of the tumbler, said spindle being provided with an axial opening formed therethrough to receive a key, said key being adapted to lock said spindle and tumbler together whereby the latter may be moved upon the rotation of the former by said key and a ward rigidly connected with said casing and disposed near the spindle to prevent the employment of an improper key, said ward and key being so constructed that a portion of the key passes through said ward.

4. In a lock of the character described, a casing, a spindle rotatably mounted therein, spaced disks pivotally mounted upon said spindle, a tumbler disposed between and rigidly connected with said disks, a plurality of sliding bolts, connecting means between the same and said disks, said spindle being provided with an axial opening for receiving a key, and a ward disposed near said spindle to prevent the employment of an improper key.

5. In a lock of the character described, a

5 casing, spaced disks disposed therein, a spindle rotatably mounted within said casing and having pivotal connection with said disks, a plurality of sliding bolts, connecting means between said sliding bolts and disks, and means to lock certain of said sliding bolts against longitudinal movement.

10 6. In a lock of the character described, a spindle pivotally mounted within said casing, a tumbler pivotally mounted upon said spindle, a bolt having slid-
15 engagement with said casing, means connecting said tumbler and bolt, said spindle being provided with an axial opening extending through its periphery, a key for in-

sertion within said axial opening, comprising a body portion to be disposed within said spindle and a tooth connected therewith adapted to extend beyond the periphery of said spindle to engage the tumbler, and a
20 ward disposed near said spindle and having an opening formed therein through which said tooth is adapted to pass.

In testimony whereof I affix my signature in presence of two witnesses.

JAMES C. LODOR.

Witnesses:

HORACE V. CONLY,
STEPHEN O. SMITH.

Copies of this patent may be obtained for five cents each, by addressing the "Commissioner of Patents, Washington, D. C."
