

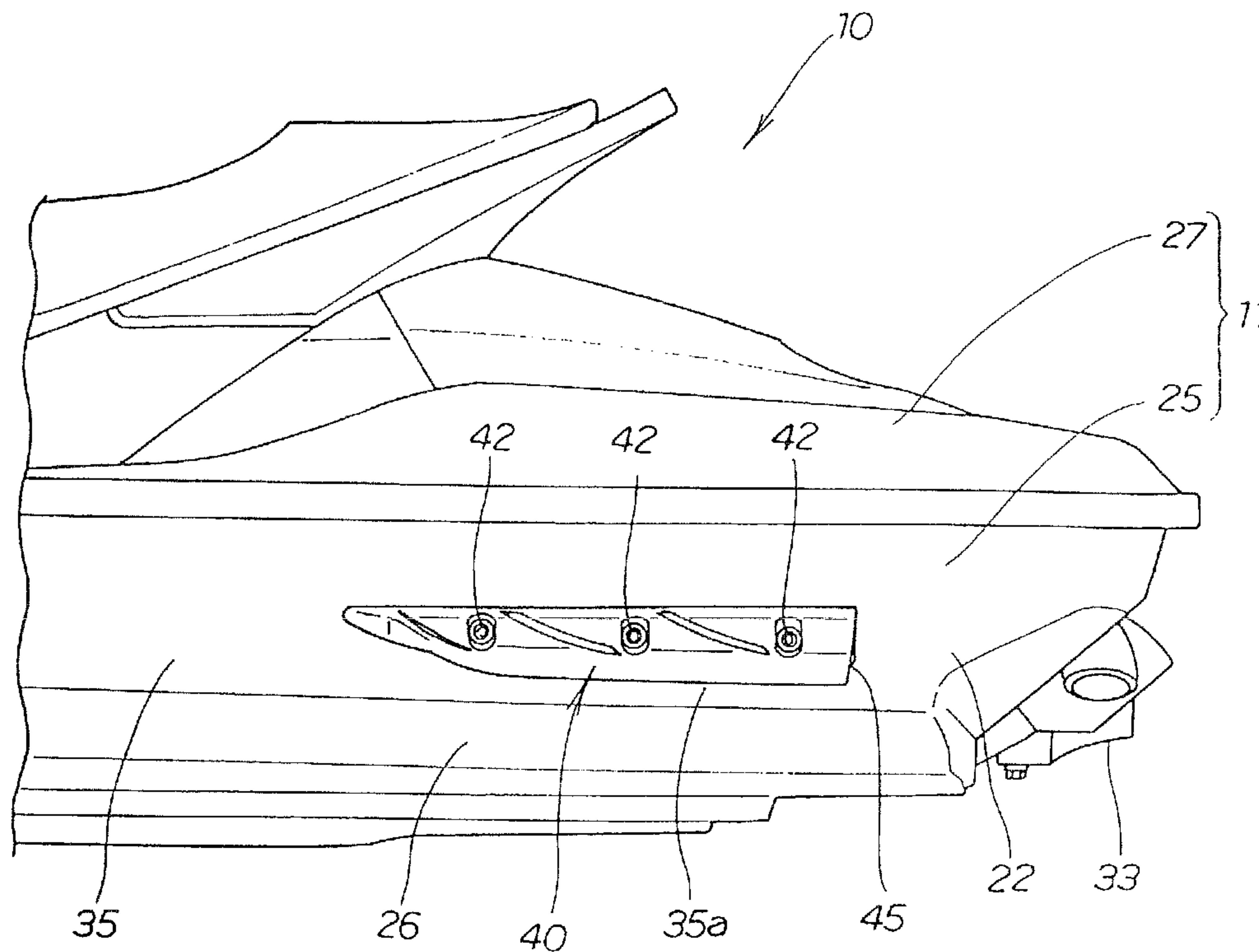

(22) Date de dépôt/Filing Date: 2004/09/08
 (41) Mise à la disp. pub./Open to Public Insp.: 2005/03/09
 (45) Date de délivrance/Issue Date: 2007/09/04
 (30) Priorité/Priority: 2003/09/09 (JP2003-317503)

(51) Cl.Int./Int.Cl. *B63B 39/06* (2006.01),
B63B 1/04 (2006.01), *B63B 1/18* (2006.01),
B63B 35/73 (2006.01)
 (72) Inventeurs/Inventors:
 KOCHI, TAKAO, JP;
 TSUCHIYA, MASAHIKO, JP;
 SHOGASE, HAJIME, JP
 (73) Propriétaire/Owner:
 HONDA MOTOR CO., LTD., JP
 (74) Agent: DENNISON ASSOCIATES

(54) Titre : PETITE EMBARCATION
 (54) Title: SMALL BOAT



(57) **Abrégé/Abstract:**

To provide a small boat that turns through a small arc turning locus when turning, that is, capable of tight turning. A small boat has left and right sponsons extending in a longitudinal direction respectively attached to left and right side walls constituting the boat body. The sponson is provided with an attachment section contacting a left side wall, a gliding section extending substantially horizontally from a lower edge of this attachment section, an inclined section connecting to a side edge of the gliding section, an upper edge of the attachment section, and projecting sections extending from an upper edge to a lower edge of the inclined section, and water flowing along the inclined section is guided by the projection sections and removed from the inclined section.

ABSTRACT OF THE DISCLOSURE

To provide a small boat that turns through a small arc turning locus when turning, that is, capable of tight turning. A small boat has left and right sponsons extending in a longitudinal direction respectively attached to left and right side walls constituting the boat body. The sponson is provided with an attachment section contacting a left side wall, a gliding section extending substantially horizontally from a lower edge of this attachment section, an inclined section connecting to a side edge of the gliding section, an upper edge of the attachment section, and projecting sections extending from an upper edge to a lower edge of the inclined section, and water flowing along the inclined section is guided by the projection sections and removed from the inclined section.

SMALL BOAT

FIELD OF THE INVENTION

- 5 The present invention relates to a small boat, and particularly to a small boat having sponsons attached to left and right side walls constituting a boat body.

BACKGROUND OF THE INVENTION

- 10 As a small boat for gliding over the surface of the sea or a lake, there is a known a small propelled boat driven by taking in water from the bottom of the boat and spraying the taken in water to the rear as a result of attaching a jet propulsion unit to the rear of the boat body and driving this jet propulsion unit with an engine. This small boat has sponsons
15 extending longitudinally provided on left and right side surfaces of the boat body. (For example, refer to Japanese patent laid open No. Hei. 10-76990 (Fig. 2).

- Japanese patent laid open No. Hei. 10-76990 will be described in the
20 following based on the drawings. Fig. 9 is a drawing for describing the basic structure of the related art. The small boat 100 has a jet propulsion unit 103 provided on the stern 102 of the boat hull 101, and left and right sponsons 106 and 107 are respectively provided on rear sections of left and right side walls 104, 105.

25

By attaching the sponsons 106, 107 on the left and right side walls, the left and right sponsons 106, 107 respectively jut outwards from the side walls 104 and 105.

A water jet is sprayed backwards from a steering nozzle 117 of the small boat 100 and the small boat 100 is moved in a straight line. When the small boat 100 is moving in a straight line, upper parts 108 and 109 of the left and right sponsons 106, 107 lift up from the water surface 111, and
5 respective gliding sections 112 and 113 of the left and right sponsons 106 and 107 come into contact with the water surface 111. In this way, a large surface area of the hull is ensured when the small boat 100 is moving.

Fig. 10 (a) and Fig. 10(b) are drawings for describing an example of a
10 turning operation of the small boat of the related art. In Fig. 10(a), during straight line movement of the small boat 100, a rider 115 operates a steering handle 116 as shown by arrows a1 to cause the steering nozzle 117 at the stern 102 to swing as shown by the arrow b1.

15 In Fig. 10(b), by moving the steering nozzle 117 to swing the water jet 118, water from the steering nozzle 117 is sprayed in an inclined direction, as shown by arrow c1. In this way, the stern 102 of the hull 101 is made to move in a rightward direction as shown by the arrow d1, and the small boat 100 begins to turn left. At this time, the small boat 100 tilts to the left
20 side, and the left sponson 106 sinks into the water. Therefore, the water resistance in the sideways direction with respect to the left sponson 106 becomes larger, and movement amount of the stern 102 in the right direction is kept small.

25 Fig. 11 is a drawing for describing an example of the small boat of the related art turning. Amount of movement of the stern 102 in the direction of arrow d1 is kept small, and the small boat is made to turn through a large arc as shown by the turning locus 119.

30 However, the small boat 100 has had many applications in recent years. For this reason, if parts suitable for turning through a large arc turning locus (large turn) or parts suitable for turning through a small arc turning locus (small turn) are provided in the small boat 100, the user selects a desired small boat 100 according to the application. Therefore, in order to
35 allow a small boat to be used with a number of different applications, it is desired to make practical use of a small boat that turns through a small arc turning locus compared to the small boat of the related art.

The present invention provides a small boat that is suitable for turning through a small arc turning locus (small turn) when turning.

5 **SUMMARY OF THE INVENTION**

The present invention is directed to a small boat having sponsons extending to the front and rear respectively attached to left and right side walls constituting a boat body, the sponsons comprising attachment sections contacting the side walls, runner sections projecting substantially
10 horizontally from a lower edge of the attachment sections, inclined sections connecting to a side edge of the runner sections and an upper edge of the attachment sections, and a projecting section projecting upwards from the inclined sections, wherein water flowing along the inclined sections is removed from the inclined sections by being guided by the
15 projecting sections.

Projection sections extending from an upper edge to a lower edge are formed on inclined parts of the sponsons. Water flowing along the inclined sections flows out from the inclined sections through these
20 projection sections. In this way, by removing water from the inclined sections of the sponsons, water resistance in the sideways direction with respect to the sponsons is kept small, and the extent of so-called grip with respect to water of the sponsons is suppressed. Accordingly, when causing the small boat to turn, by making the stern of the hull move a
25 comparatively large amount to an opposite side to the turning direction, turning through a small arc turning locus (small turn) can be achieved.

In an aspect of the invention the inclined sections are inclined at a downward gradient towards the lower edge from the upper edge, and the
30 projection section formed projecting so as to extend rearwards from the lower edge of the inclined section towards the lower edge.

Here, in order to remove water flowing along the inclined sections from the inclined sections as a result of being guided by these projection
35 sections, it is necessary to have water flow smoothly. Here, the inclined sections are inclined at a downward gradient towards the lower edge from the upper edge, and the projection section is formed projecting so as to

extend rearwards from the lower edge of the inclined section towards the lower edge. By tilting the inclined sections at a downward gradient towards the lower edge from the upper edge, water is guided in an outward direction by the inclined sections. It is therefore possible to have
5 smooth flow along the inclined sections.

Also, by forming the projection sections so as to extend rearwards from an upper edge to a lower edge of the inclined sections, flow of water flowing in an outward direction of the inclined sections is not blocked by the
10 projection sections. In this way, water flows smoothly along the inclined sections, and flow of water is not blocked by the projection sections, which means that water flowing along the inclined sections of the sponsons is guided by the projection sections and it is possible to reliably remove water from the inclined sections. Accordingly, when causing the small boat to
15 turn, by making the stern of the hull move a comparatively large amount to an opposite side to the turning direction, turning through a small arc turning locus (small turn) can be achieved.

In another aspect of the invention the sponsons are attached to the side
20 wall with attachment members such as bolts, and the projection section is provided avoiding the attachment members.

By providing projection sections avoiding the attachment members for attaching the sponsons, it is possible to easily ensure sites for providing
25 the projection sections without newly providing them.

In a further aspect of the invention a plurality of the projection sections are provided between a front end and a rear end of the sponson, and among the plurality of projection sections projections that are provided in
30 the front most row and at the front end of the sponson are formed smaller than the other projection sections.

Among the plurality of projection sections, by making the projections arranged in the front most row and provided on the front end of the
35 sponsons small it is possible to make water flow smoothly to the rear of the sponsons. Accordingly, it is possible to reliably remove water flowing along the inclined sections from the inclined sections by being favorably

guided. In this way, when causing the small boat to turn, by making the stern of the hull move a comparatively large amount to an opposite side to the turning direction, turning through a small arc turning locus (small turn) can be achieved.

5

BRIEF DESCRIPTION OF THE DRAWINGS

Preferred embodiments of the invention are shown in the drawings, wherein:

10 Fig. 1 is a side view of a small boat of the present invention.

Fig. 2 is a side view showing main parts of a small boat of the present invention.

15 Fig. 3 is a perspective view showing a sponson provided on a small boat of the present invention.

Fig. 4 is a side view showing a sponson provided on a small boat of the present invention.

20

Fig. 5 is a cross sectional drawing along line 5 - 5 in Fig.4.

Fig. 6 is a drawing for describing a state where a small boat of the present invention is moving.

25

Fig. 7 is a drawing for describing a state where sponsons of the small boat of the present invention sink into the water.

30 Fig. 8 is a drawing for describing a state where a small boat of the present invention is turning left.

Fig. 9 is a drawing for describing the basic structure of the related art.

35 Fig. 10 is a drawing for describing an example of a turning operation of the small boat of the related art.

Fig. 11 is a drawing for describing an example of the small boat of the related art turning.

DETAILED DESCRIPTION OF THE PREFERRED EMBODIMENTS

5 A preferred embodiment of the present invention will now be described in the following based on the attached drawings. The drawings are viewed in the direction of the reference numerals. Fig. 1 is a side view of a small boat of the present invention. The small boat 10 has a fuel tank 13 attached to a front part 12 of the boat body 11, and is provided with a steering handle above this fuel tank. A saddle type seat 15 is provided behind the steering handle 14, with an engine provided beneath the seat 15, a propulsion unit chamber 23 provided on a stern 22 behind the engine 16, and a jet propulsion unit 24 provided on the propulsion unit chamber 23. The body 11 forms a boat bottom 26 side with the hull 25, and a deck 27 overlaps this hull 25.

The jet propulsion unit 24 has a housing 29 extending rearwards from an inlet 28 of the boat bottom 26, with an impeller 31 being rotatably attached inside the housing 29, the impeller 31 being connected to a drive shaft 32 of the engine 16. By rotating the impeller 31 with the engine 16, water is taken in from the inlet 28 of the boat bottom 26, and the taken in water passes through the housing 29 and is introduced to a steering nozzle as jet water. Jet water that has been introduced to the steering nozzle 33 causes the small boat to travel by being sprayed from a rear end part of the steering nozzle 33.

Fig. 2 is a side view showing main parts of a small boat of the present invention. A boat bottom 26 side of the boat body 11 is formed by the hull 25, and left and right sponsons 40, 41 extending longitudinally are respectively attached to left and right side walls 35, 36 (refer to Fig. 7a for the right side wall 36) forming the hull 25. The right sponson 41 is shown in Fig. 6(b) and Fig. 7 (a). By attaching the sponsons 40, 41 to the left and right side walls 35, 36, the left and right sponsons 40, 41 jut outwards from the respective side walls 35 and 36.

35 More specifically, the left sponson 40 is a hydrofoil-shaped member attached to a site, from among rear sections 35a of the left side wall 35,

close to the boat bottom 26 using 3 bolts 42... (... represents that there are a plurality). Also, the right sponson 41 shown in Fig. 7(a) is a hydrofoil shaped member, the same as the left sponson 41, attached to a site, from among rear sections 36a of the right side wall 36, close to the boat bottom 26 using 3 bolts 42... (not shown in the drawing).

The left and right sponsons 40, 41 rise up from the water when the small boat travels in a straight line, and bottom surfaces of the left and right sponsons 40, 41, that is, the gliding sections 45, 46 (refer to Fig. 7(a)), come into contact with the water surface. In this way, by causing the gliding surfaces 46 and 46 of the left and right sponsons to come into contact with the water surface, a large surface area is ensured from the boat body when the small boat 10 is traveling. The left and right sponsons 40, 41 are left right symmetrical members, and so the left sponson 40 will be described but description of the right sponson 41 will be omitted.

Fig. 3 is a perspective view showing a sponson provided on a small boat of the present invention. The sponson 40 is formed so as to extend rearwards from the front of the boat body 11, and is a hydrofoil-shaped member having a fine tip shape at the front end 43. This sponson is provided with an attachment section 47 contacting a left side wall 35 of the hull 25, a gliding section 45 extending substantially horizontally from a lower edge 48 of this attachment section 47, a protruding section 52 protruding downwards from a side edge 51 of the gliding section 45, an inclined section 53 connecting to an upper edge 49 of the protruding section 52 and the attachment section 47, and three projecting sections 57... extending from an upper edge to a lower edge of the inclined section 53, and water flowing along the inclined sections 53 is guided by the projection sections 57... and removed from the inclined section 53.

Respective indents 61... for attachment are provided at front part 53a, middle part 53b and rear part 53c of the inclined section 53, and attachment holes 62... (refer also to Fig. 5) are provided in the bottoms of the indents 61..., that is, in attachment sections 47. Bolts 42... are fitted into the attachment holes 62..., the fitted bolts 42 are fitted into attachment holes 63 of the left side wall 35, and nuts 64... (refer also to Fig. 5) are screwed on to the on to the bolts 42... projecting to the rear side of the hull 25 to attach

the sponson 40 to the left side wall. Bolts 42... and nuts 64... constitute attachment members for attaching the sponson 40 to the left side wall 35 of the hull 25.

- 5 The sponson 40 attached to the left side wall 35 with attachment members such as the nuts 64 and bolts 42, and the projection section 57 is provided avoiding the bolts 42... (attachment members).By providing the projection section 57 avoiding the bolts 42... (attachment members) for attaching the sponson 40 in this way, it is possible to easily ensure a site for providing
10 the projection sections without new providing them.

The inclined section 53 is a member inclined at a downward gradient towards the lower edge 55 from the upper edge 54. Three projection sections 57... extending from an upper edge 54 to a lower edge 55 of the
15 inclined section 53 are formed on the inclined section 53. The projection sections 57... are at fine streak shaped sites projecting to a specified height H (refer also to Fig. 5) from the rear surface 56 of the inclined section 53.

The projection sections are members formed with a downward gradient at
20 an inclination angle of θ so as to extend rearwards from an upper edge 54 to a lower edge 55 of the inclined section 53 and formed to a length L. The height H, length L and inclination angle θ of the projection section 57 is appropriately selected according to the turning conditions of the small boat
10.

25

In this way, a plurality (3) of projection sections 57... are provided between the front end 43 and rear end 44 of the sponson 40. Then, among the plurality of projection sections 57..., the projection section 57 arranged in the front most row and provided at the front end of the sponson 40 (in the
30 following, for convenience, the projection of the front most row will be described as projection section 57a) is formed smaller than the other projection sections 57, 57.

By making the front most projection section 57a smaller than the other
35 two projection sections 57, 57, it is possible for water to flow smoothly to the rear of the sponson 40. Accordingly, it is possible to reliably remove water flowing along the inclined section 53 of the sponson 40 from the

inclined section 53 by being favorably guided by the projection sections 57, 57 behind the front most projection section 57a.

5 The reason that the inclined section 53 is inclined at a downward gradient towards the lower edge 55 from the upper edge 54, and the projection sections 57, 57 are formed projecting so as to extend rearwards from the upper edge 54 of the inclined section 53 towards the lower edge 55 will now be described in detail.

10 Fig. 4 is a side view showing a sponson provided on a small boat of the present invention. The sponson 40 is attached to the left side wall 35 of the hull 25 using bolts 42. By turning the small boat 100 to the left, the sponson 40 sinks into the water. At this time, water flows as shown by the arrows a, is guided by the projection sections 57, 57 (including the front
15 most projection section 57a), and rises up from the surface 56 of the inclined section 53. Therefore it is possible to have separation layers 65 formed by small vortex currents sites to the rear of the projection sections 57... , and in the separation layers 65...it is possible to remove water from the surface 56 of the inclined section 53 .

20

In this way, by removing water from the inclined section 53 of the sponson 40, water resistance in the sideways direction with respect to the sponson 40 is kept small, and it is possible to suppress the extent of so-called grip with respect to water of the sponson 40. Accordingly, when
25 causing the small boat 10 to turn, the rear of stern 22 of the boat body 11 (refer to Fig. 2) is made to move a comparatively large amount to an opposite side to the turning side, and it is possible for the small boat 10 to turn through a small arc turning locus.

30 However, in order to remove water flowing along the inclined section 53 of the sponson 40 from the inclined section 53 as a result of being guided by these projection sections 57 (including the projection section of the front most row), it is necessary to have water flow smoothly. Here, the inclined section 53 is inclined at a downward gradient towards the lower
35 edge 55 from the upper edge 54, and the projection sections 57, 57 (including the projection section of the front most row) are formed projecting so as to extend rearwards from the upper edge 54 of the inclined

section 53 towards the lower edge 55. By tilting the inclined section 53 at a downward gradient towards the lower edge 55 from the upper edge 54, water is guided in an outward direction by the inclined section 53. It is therefore possible to have smooth flow along the inclined section 53.

5

Also, by forming the projection section 57 so as to extend rearwards from an upper edge 54 to a lower edge 55 of the inclined section 53, flow of water is not impeded by the projection sections 57...In this way, water flows smoothly along the inclined section 53, and flow of water is not impeded by the projection sections 57..., which means that water flowing along the inclined section 53 of the sponson 40 is guided by the projection sections 57... and it is possible to reliably remove water from the inclined section 53. Accordingly, when causing the small boat 10 to turn, the stern 22 of the boat body 11 (refer to Fig. 2) is made to move a comparatively large amount to an opposite side to the turning direction and it is possible for the small boat 10 to turn through a small arc turning locus.

10

15

Fig. 5 is a cross sectional drawing along line 5 - 5 in Fig. 4. Indents 61... are provided in the inclined section 53, and attachment holes 62... are provided in the bottoms of the indents 61..., namely the attachment sections 47. Bolts 42... are fitted into the attachment holes 62..., the fitted bolts 42 are fitted into attachment holes 63 of the left side wall 35, and nuts 64... are screwed on to the bolts 42... projecting to the rear side of the left side wall 35 to attach the sponson 40 to the left side wall 35.

20

25

By attaching the sponson 40 to the left side wall 35 of the hull 25 using bolts 42, the attachment section 47 is brought into contact with the left side wall 35 of the hull 25. The gliding section 45 extends substantially horizontally from a lower edge 48 of this attachment section 47, with a protruding section 52 protruding downwards from a side edge 51 of the gliding section 45, the protruding section 52 and an upper edge of the attachment section 47 being connected by the inclined section 53. In this way, the gliding section 45 of the sponson 40 and the inclined section 53 extend outwards from the left side wall 35. Three projection sections 57... (refer to Fig. 3 and Fig. 4) extend from an upper edge 54 to a lower edge 55 of the inclined section 53 extending from the left side wall 35.

30

35

Next, operation of the sponson 40 provided in the small boat 10 of the present invention will be described based on Fig. 6 - Fig. 8.

5 Fig. 6(a) and Fig. 6(b) are drawings for describing a state where a small boat of the present invention is moving. In Fig. 6(a), a jet propulsion unit 24 of the small boat 10 is driven by an engine 16 (refer to Fig. 1) to suck in water from an intake 26 at the boat bottom 26, and the sucked in water is sprayed to the rear in the direction of arrow b as a water jet 69 from the steering nozzle 33. The small boat 10 moves in a straight line as a result of the
10 water jet 69 being sprayed.

As a result of the small boat 10 traveling in a straight line, the left and right sponsons 40, 41 (refer to Fig. 6(b) for the right sponson 41) rise up from the water surface 68a, and the gliding sections 45, 46 (the gliding
15 section 46 is not shown in the drawings) of the left and right sponsons 40, 41 come into contact with the water surface 68a. In this way, by causing the gliding surfaces 46 and 46 of the left and right sponsons to come into contact with the water surface, a large surface area is ensured from the boat body when the small boat 10 is traveling.

20 In Fig. 6(b), during rectilinear movement of the small boat 10, a rider 70 operates a steering handle 14 as shown by arrows c to cause the steering nozzle 33 provided at the stern 22 of the boat body 11 to swing to the left side as shown by the arrow d.

25 Fig. 7(a) and Fig. 7(b) are drawings for describing a state where sponsons of the small boat of the present invention sink into the water.

In Fig. 7(a)), as a result of swing movement of the steering nozzle 33 in the
30 left side direction, the water jet 69 from the steering nozzle 33 is sprayed to the left side rear, as shown by arrow e. In this way, the stern 22 of the small boat 10 is made to move in the direction as shown by the arrow f, and begins to turn left. At this time, the small boat 100 tilts to the turning side, namely to the left side, and the left sponson 40 sinks into the water.

35 In Fig. 7(b), as a result of the sponson 40 sinking into the water, water 68 (refer to Fig. 7(a)) flows as shown by the arrows g, is guided by the

projection sections 57... (including the front most projection section 57a), and rises up from the surface 56 of the inclined section 53. Therefore it is possible to have a separation layers 65 at sites to the rear of the projection sections 57... , and in the separation layers 65... water 68 is removed from the surface 56 of the inclined section 53. In this way, by removing water from the inclined section 53 of the sponson 40, resistance of water 68 in the sideways direction with respect to the sponson 40 is kept small, and it is possible to suppress the extent of so-called grip with respect to water of the sponson 40.

10

Fig. 8(a) and Fig. 8(b) are drawings for describing a state where a small boat of the present invention is turning left. In Fig. 8(a), by keeping resistance of water 68 in a sideways direction with respect to the sponson 40 small, the stern 22 of the boat body 11 is caused to move a comparatively large amount as shown by the arrow h to a side opposite to the turning side, under the power of the spray of the water jet 69. By causing the stern 22 of the boat body 11 to move as shown by arrow h, the bow of the boat body 11 is made to move as shown by arrow i.

20 In Fig. 8(b), by causing the stern 22 of the boat body 11 to move a lot, the small boat 10 turns through a small arc turning locus as the turning locus 72 (that is, a small turn). It is therefore possible to apply the small boat 10 to situation that required tight turning capability.

25 On the contrary, since with the related art sponsons the projections sections 27 are not provided, it is difficult to remove water from the inclined section of the sponsons. Therefore, the water resistance in the sideways direction with respect to the sponsons becomes larger, and so called grip with respect to water of the sponsons is increased. Therefore, amount of movement of the stern is kept small, and the small boat is made to turn through a large arc. In this way, it is possible to apply the small boat to situations that require large turning circle capability.

35 With the above described embodiment, a description has been given of an example where the small boat 20 of the present invention has been applied to a small propelled craft provided with a jet propulsion unit 24 at

a rear part of the boat body 11, but the invention is not thus limited and can be applied to other small boats.

Also, with the above embodiment description has been given of an
5 example where three projections sections 57... are provided on the
inclined section 53 of the sponson 40, but the number of projection
sections is not limited to three and it is possible to provide 1 - 2 or greater
than 4 projection sections 57. Also, the shape of the projection sections 57
is not limited to the examples in the embodiment, and appropriate
10 modifications are possible. In short, any shape is possible as long as it is
possible to remove water from the inclined sections 53 of the sponson 40.

Also, with the above described embodiment, description has been given of
an example where bolts 42... and nuts 64... are used as attachment
15 members for attaching the sponson to the left side wall of the hull 25, but
the attachment members are not thus limited and it is possible to use
other members as the attachment members.

The present invention applies to small boats having left and right
20 sponsons attached to left and right side walls constituting the boat body.

With the present invention, by forming the projection sections on the
inclined sections of the sponsons, the small boat is made to turn through a
small arc turning locus, and there is the advantage that it is possible to
25 obtain favorable turning characteristics according to the application. With
an embodiment of the invention, by forming the inclined sections at a
downward gradient and reliably removing water from the inclined
sections by forming the projections extending to the rear, the small boat is
made to turn through a small arc turning locus, and there is the advantage
30 that it is possible to obtain favorable turning characteristics according to
the application.

With another embodiment of the invention, by easily ensuring sites for
provision of the projections without newly providing them, there is the
35 advantage that it is possible to make the sponsons in a suitable shape.

With a further embodiment of the invention, by forming, among the plurality of projections, those projections that are arranged in the front most row and provided on the front section of the sponsons smaller, the small boat is made to turn through a small arc turning locus, and there is
5 the advantage that it is possible to obtain favorable turning characteristics according to the application.

Although various preferred embodiments of the present invention have been described herein in detail, it will be appreciated by those skilled in the
10 art, that variations may be made thereto without departing from the spirit of the invention or the scope of the appended claims.

THE EMBODIMENTS OF THE INVENTION IN WHICH AN EXCLUSIVE PROPERTY OR PRIVILEGE IS CLAIMED ARE DEFINED AS FOLLOWS:

1. A watercraft comprising:
 - a boat body having left and right side walls extending longitudinally from a front and a rear portion of the boat body;
 - a right side sponson extending longitudinally along the right side wall; and
 - a left side sponson extending longitudinally along the left side wall, wherein said left and right sponsons include:
 - attachment sections contacting the respective side walls,
 - runner sections projecting substantially horizontally from a lower edge of the attachment sections,
 - inclined sections connecting to a side edge of the runner sections and an upper edge of the attachment sections,
 - at least one projection section projecting outwardly from the inclined sections and downwardly and rearwardly angled; and,
 - wherein in use water flowing along the inclined sections separates from the inclined sections by being guided by the projecting sections.
2. A watercraft as claimed in claim 1 wherein the at least one projection of each sponson includes three separate projection sections.
3. A watercraft as claimed in claim 1 wherein the at least one projection section includes three separate and longitudinally spaced apart projection sections on each of said right and left sponsons.

4. The watercraft according to claim 1, 2 or 3 wherein the inclined sections are inclined at a downward gradient towards a lower edge of the inclined sections from an upper edge of the inclined sections.
5. The watercraft according to claim 1, wherein the projection section of each sponson is formed projecting so as to extend rearwardly from an upper edge of the inclined sections toward a lower edge of the inclined sections.
6. The watercraft according to claim 1, wherein the at least one projection section is a raised rib extending outwardly from an outer surface of the respective right and left sponson.
7. The watercraft according to claim 1, 2 or 3, wherein each of said sponsons is attached to the respective side wail with attachment members, and the projection section is provided on said respective sponson in a position spaced from said attachment members.
8. The watercraft according to claim 2 or 3, wherein the three projection sections are provided between a front end and a rear end of each of said sponsons, said three projection sections including a forward most projection section, a rearward most projection section, and a middle projection section.
9. The watercraft according to claim 8, wherein the forward most projection section of said three projection sections on each of said sponsons is smaller in size than said rearward most projection section.
10. A sponson of a watercraft, said sponson comprising,

an attachment section capable of contacting a respective side wall of the watercraft,

a runner section projecting substantially horizontally from a lower edge of the attachment section,

an inclined section connected to a side edge of the runner section and an upper edge of the attachment section, and

at least one projection section projecting outwardly from the inclined section,

wherein said at least one projection section is a raised rib extending rearwardly and downwardly at an angle with respect to a longitudinal waterline of said sponson, and

wherein the at least one projection section includes three separate and longitudinally spaced apart projection sections.

11. The sponson according to claim 10, wherein the inclined section is inclined at a downward gradient to toward a lower edge of the inclined section from an upper edge of the inclined section.

12. The sponson according to claim 11, wherein the projection section is formed projecting so as to extend rearwardly from an upper edge of the inclined section toward a lower edge of the inclined section.

13. The sponson according to claim 10, further including a recessed area for an attachment member, said recessed area being provided in a position between adjacent projection sections.

14. The sponson according to claim 10, wherein a plurality of the projection sections are provided between a front end and a rear end of said

sponson, said projection sections including a forward most projection section and a rearward most projection section.

15. The sponson according to claim 19, wherein the forward most projection section of said plurality of projection sections on each of said sponsons is smaller in size than said rearward most projection section.

16. A sponson of a watercraft, said sponson comprising:

an attachment section capable of contacting a respective side wall of the watercraft,

a runner section projecting substantially horizontally from a lower edge of the attachment section,

an inclined section connected to a side edge of the runner section and an upper edge of the attachment section,

a plurality of separate and longitudinally spaced apart projection sections projecting outwardly from the inclined section, and

a recessed area on the inclined section for an attachment member, said recessed area being provided in a position between adjacent projection sections,

wherein each of said plurality of separate and longitudinally spaced apart projection sections is a raised rib extending rearwardly and at an angle with respect to a longitudinal waterline of said sponson.

FIG. 1

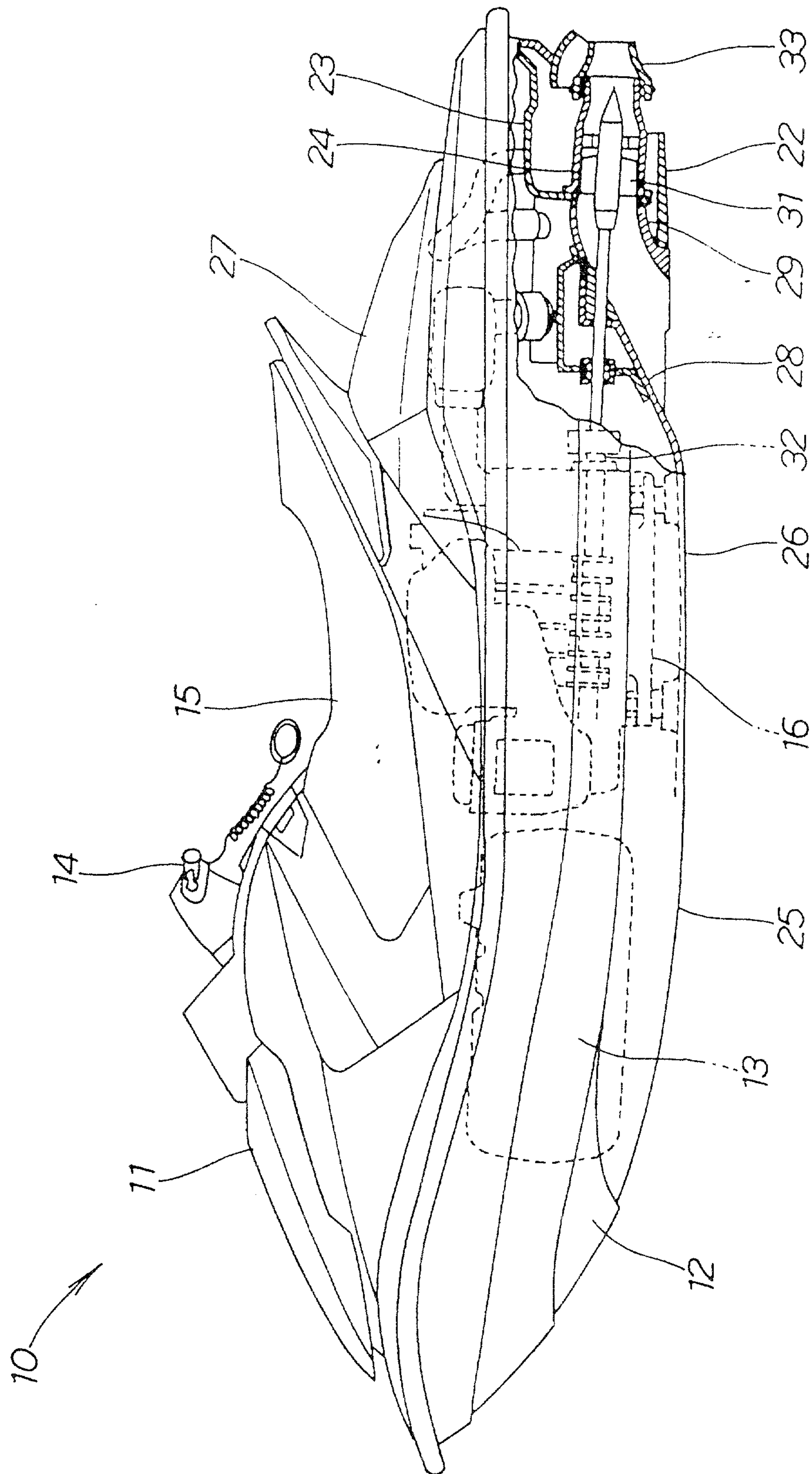

FIG. 2

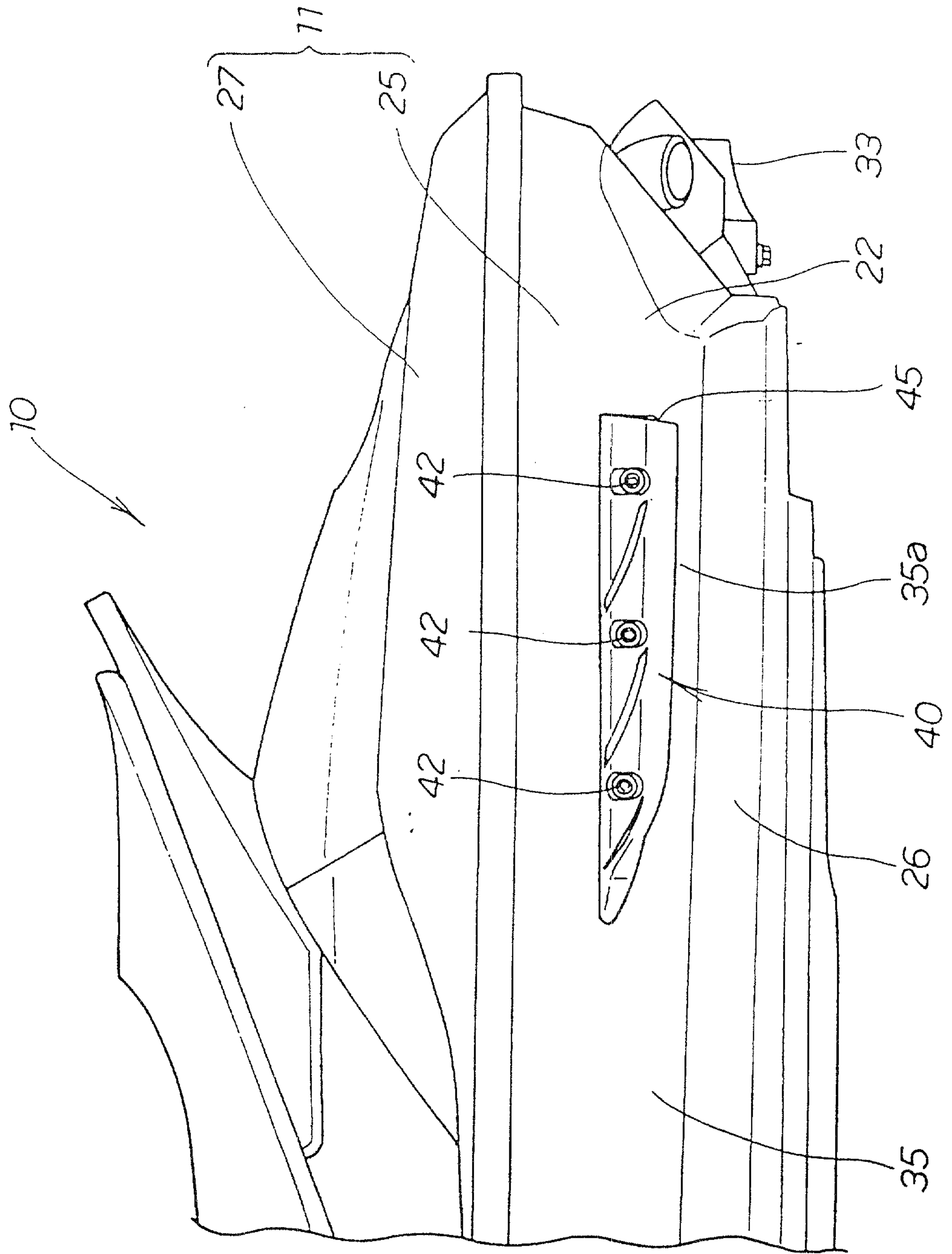

FIG. 3

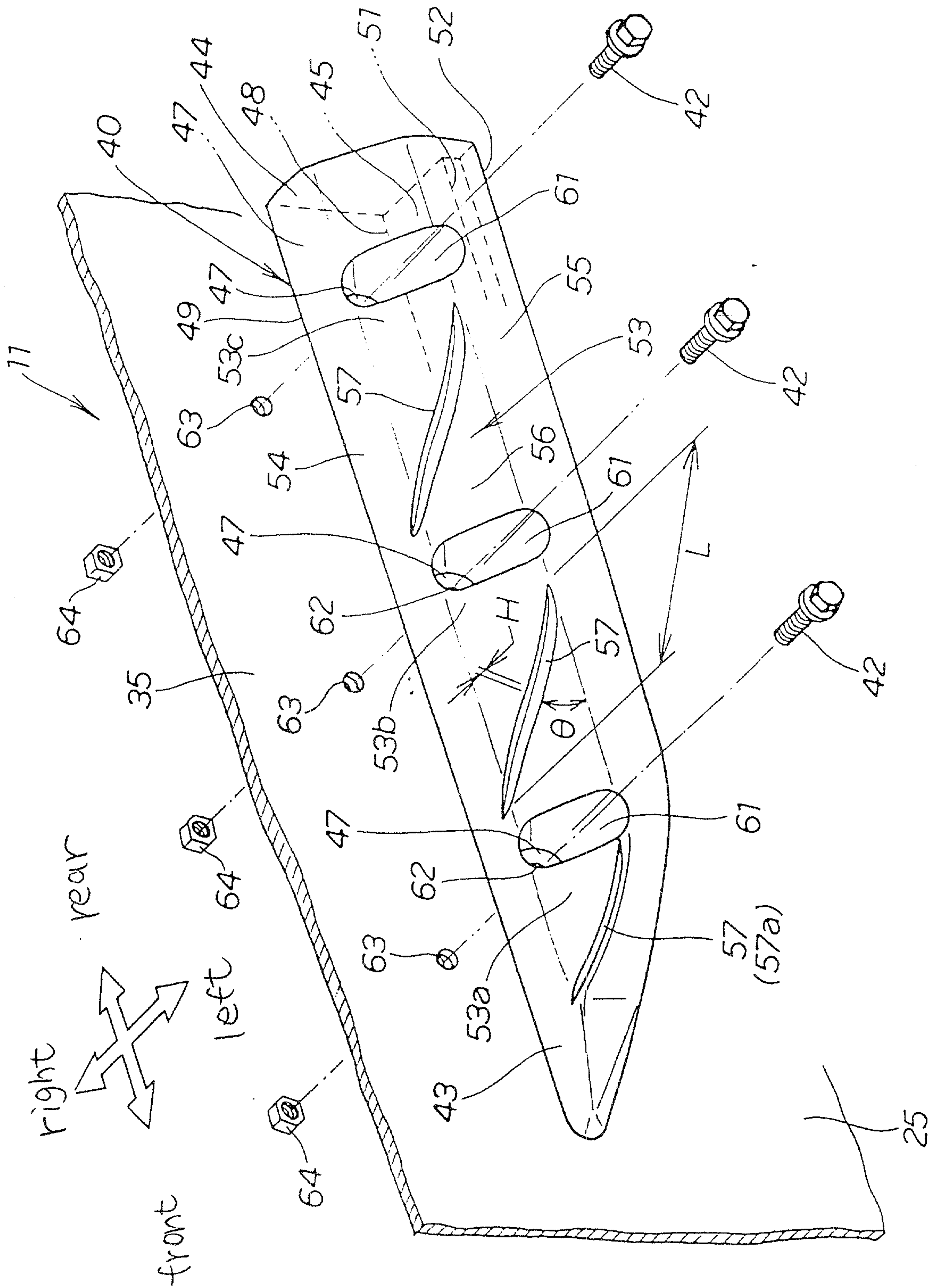

FIG. 4

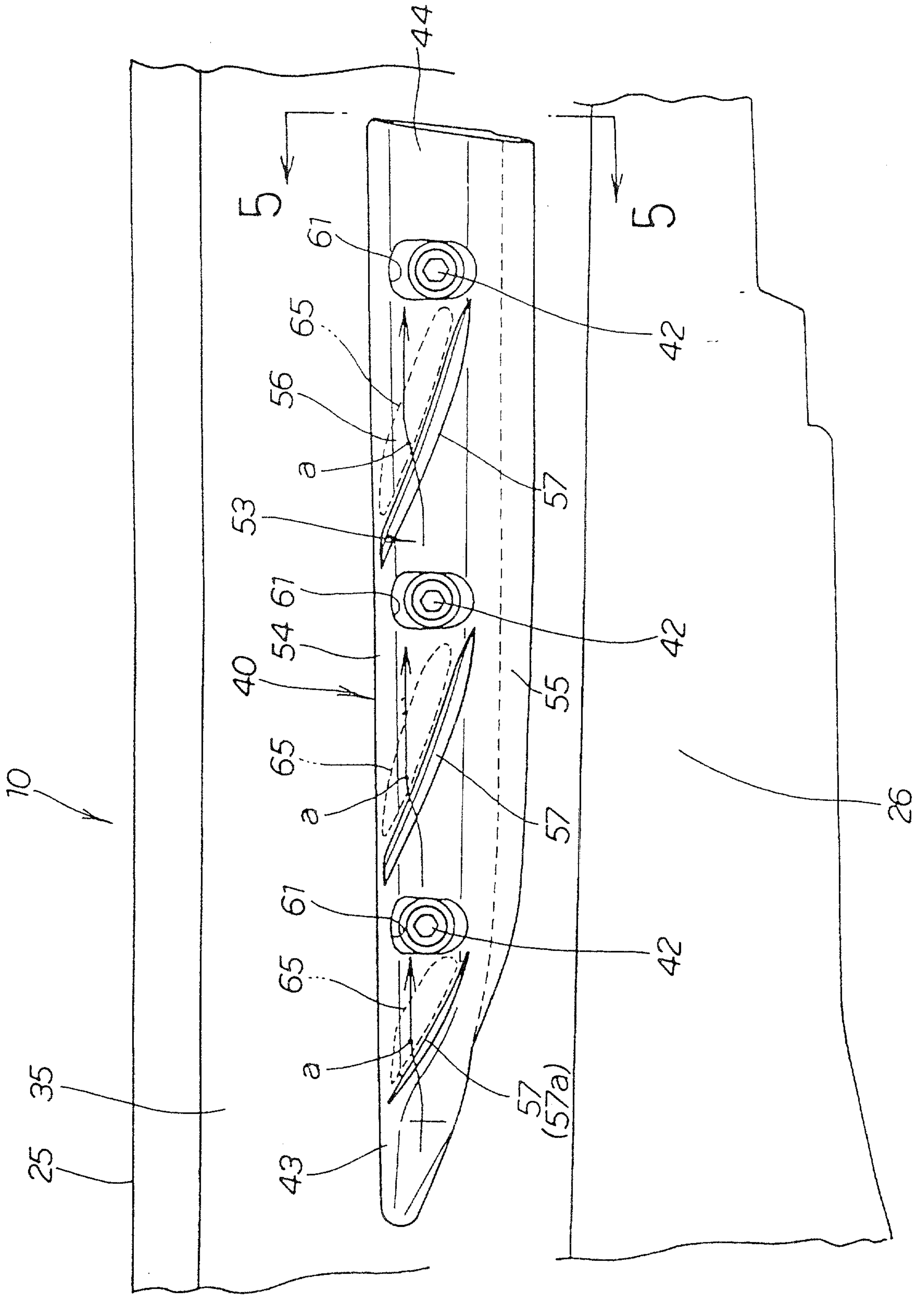

FIG. 5

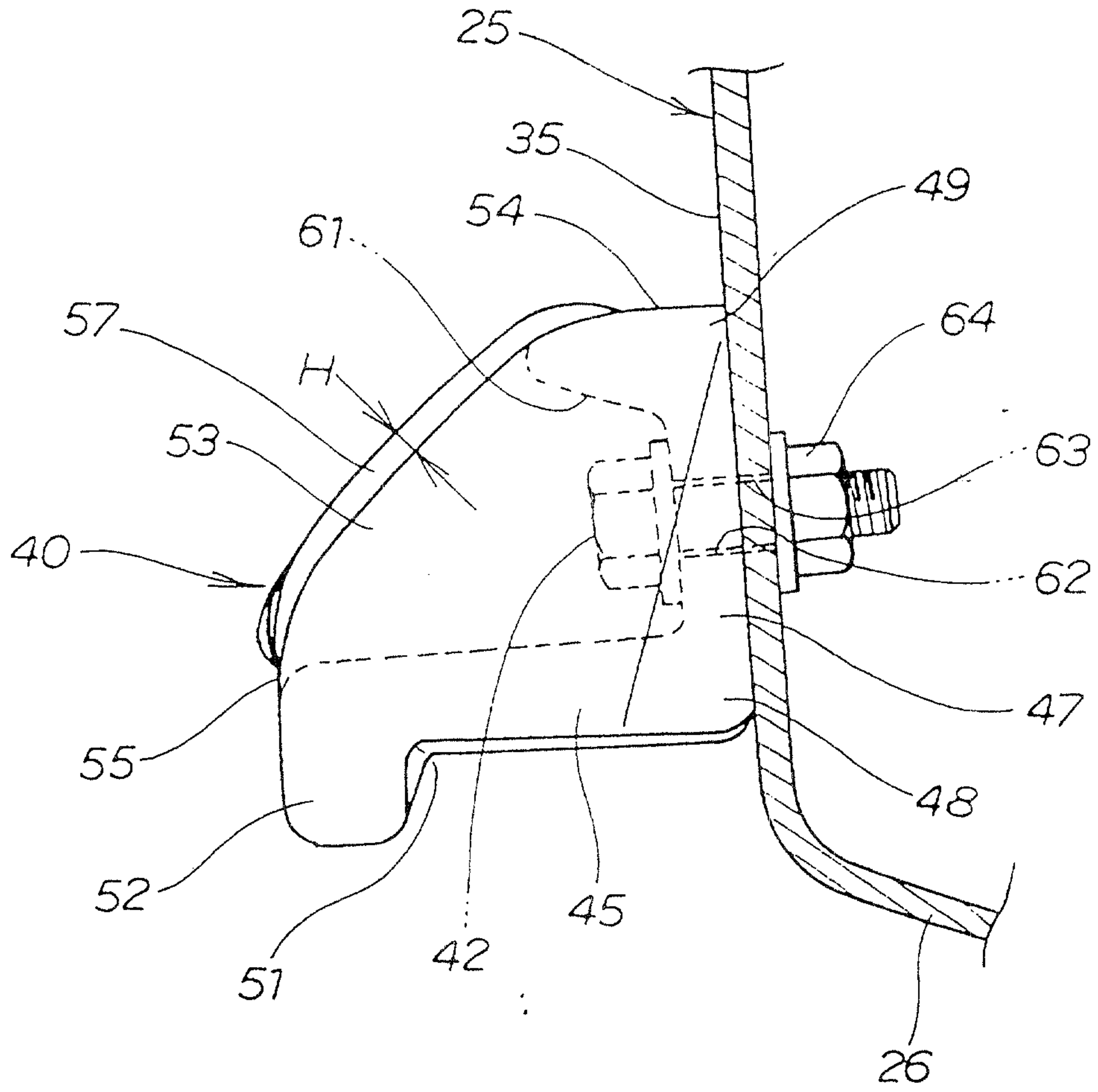
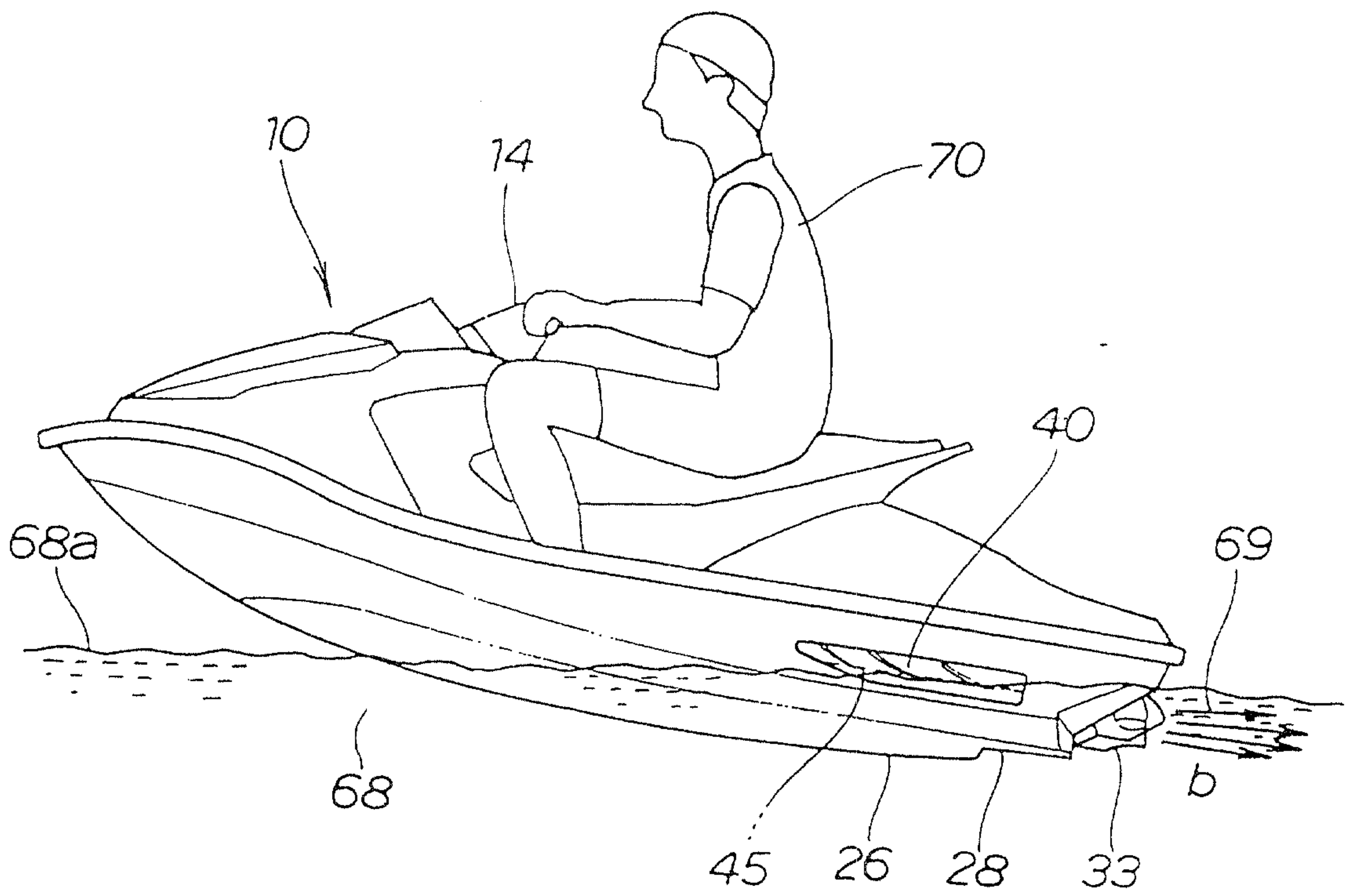

FIG. 6

(a)



(b)

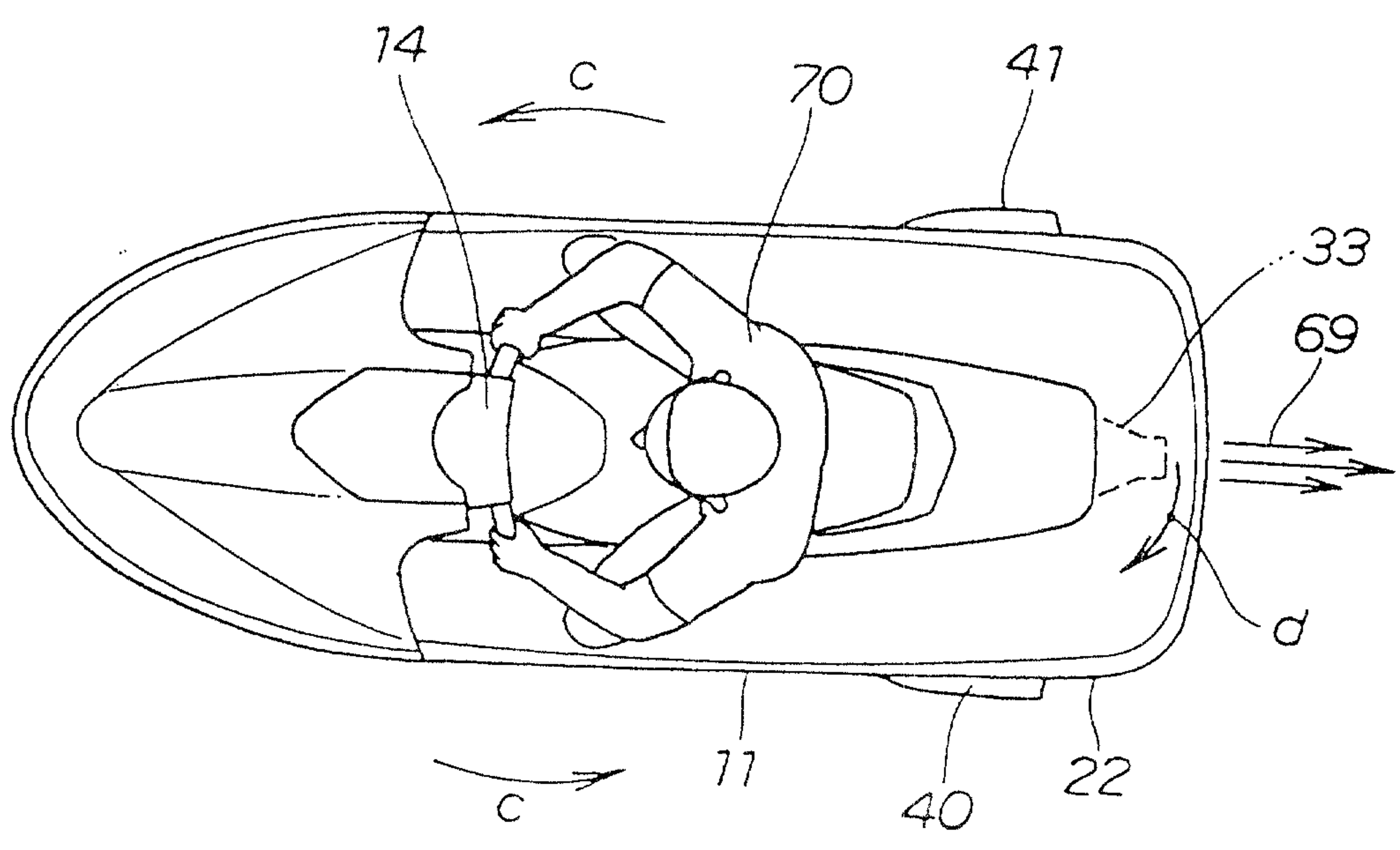

FIG. 7

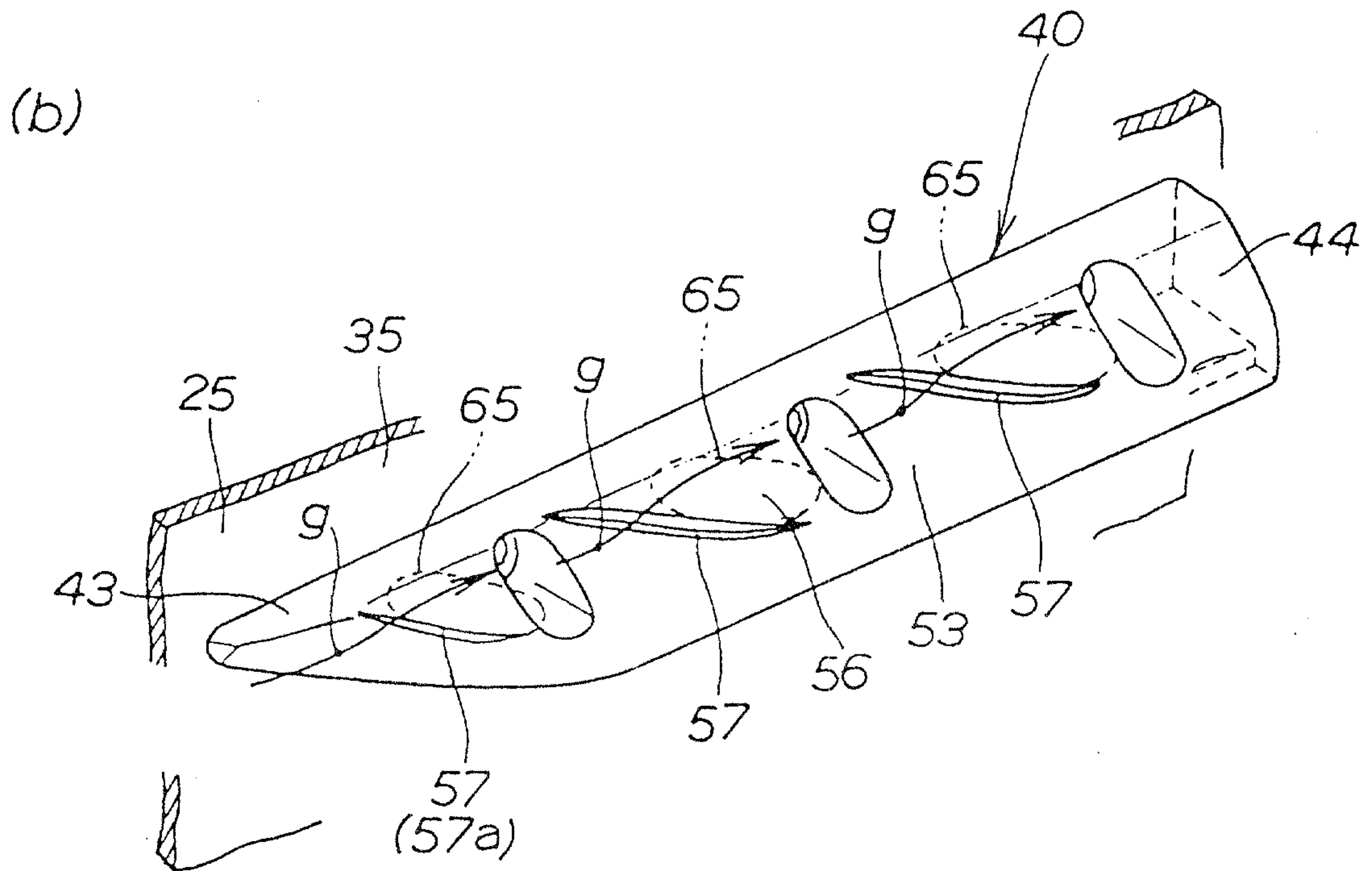
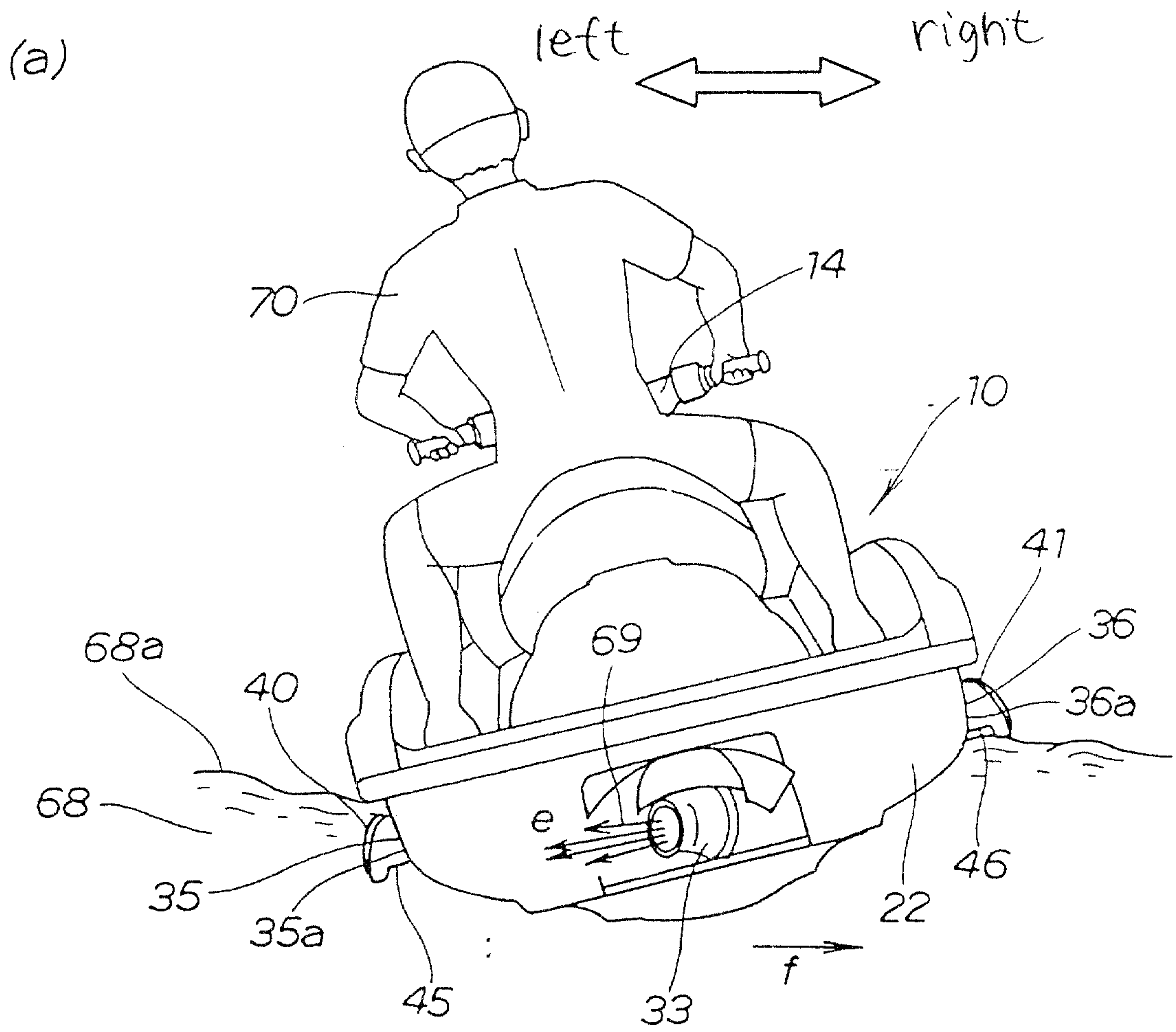
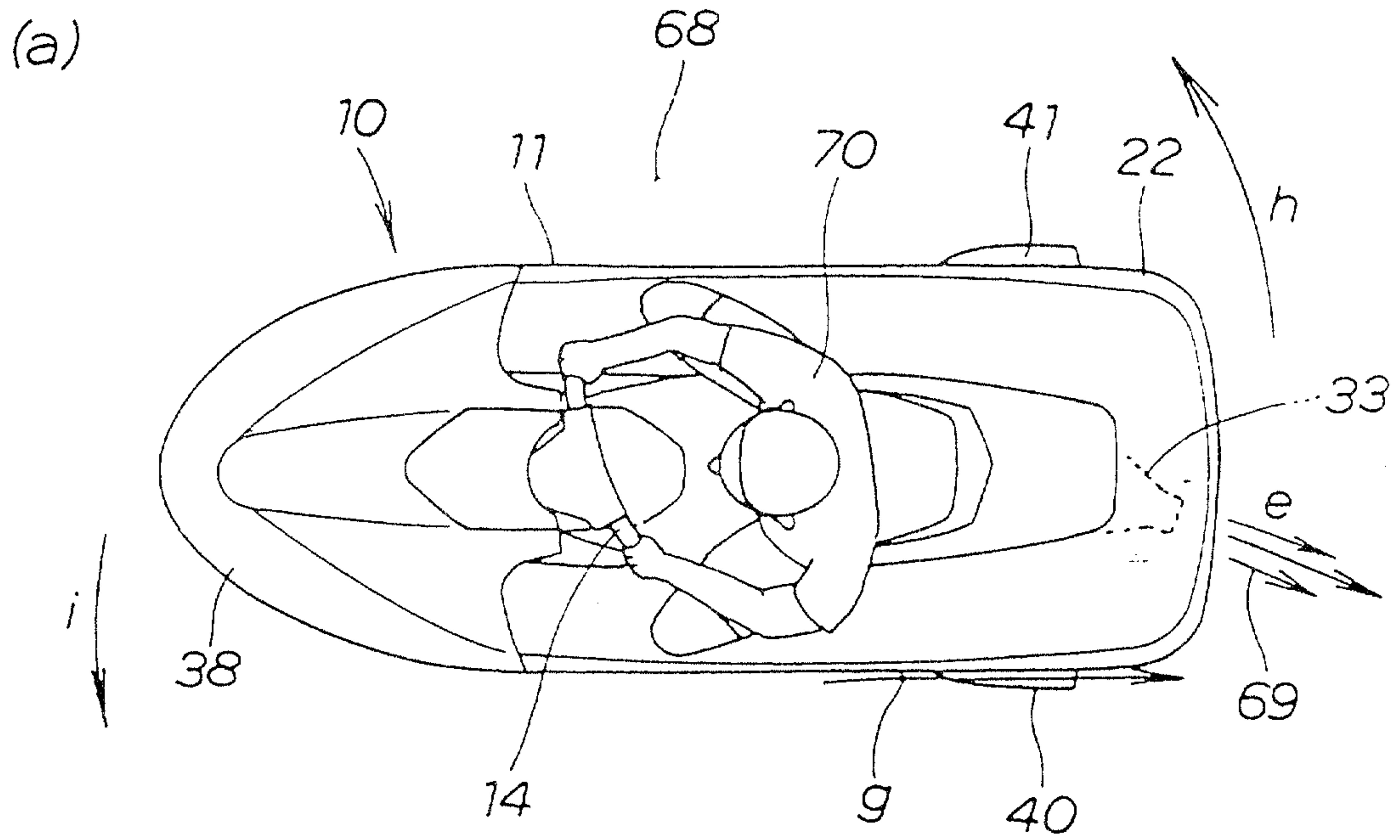

FIG. 8



(b)

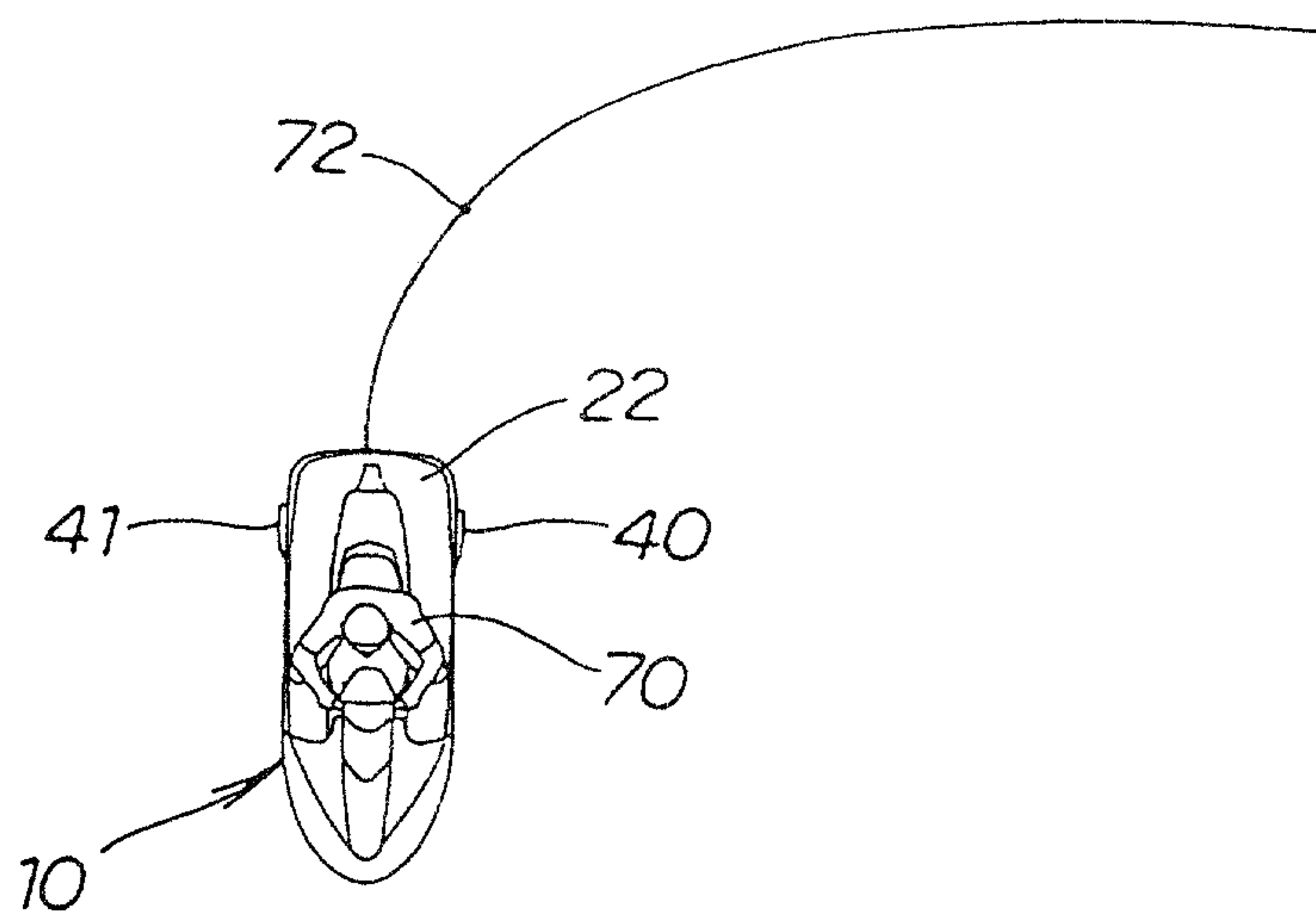

FIG. 9

left ↔ right

PRIOR ART

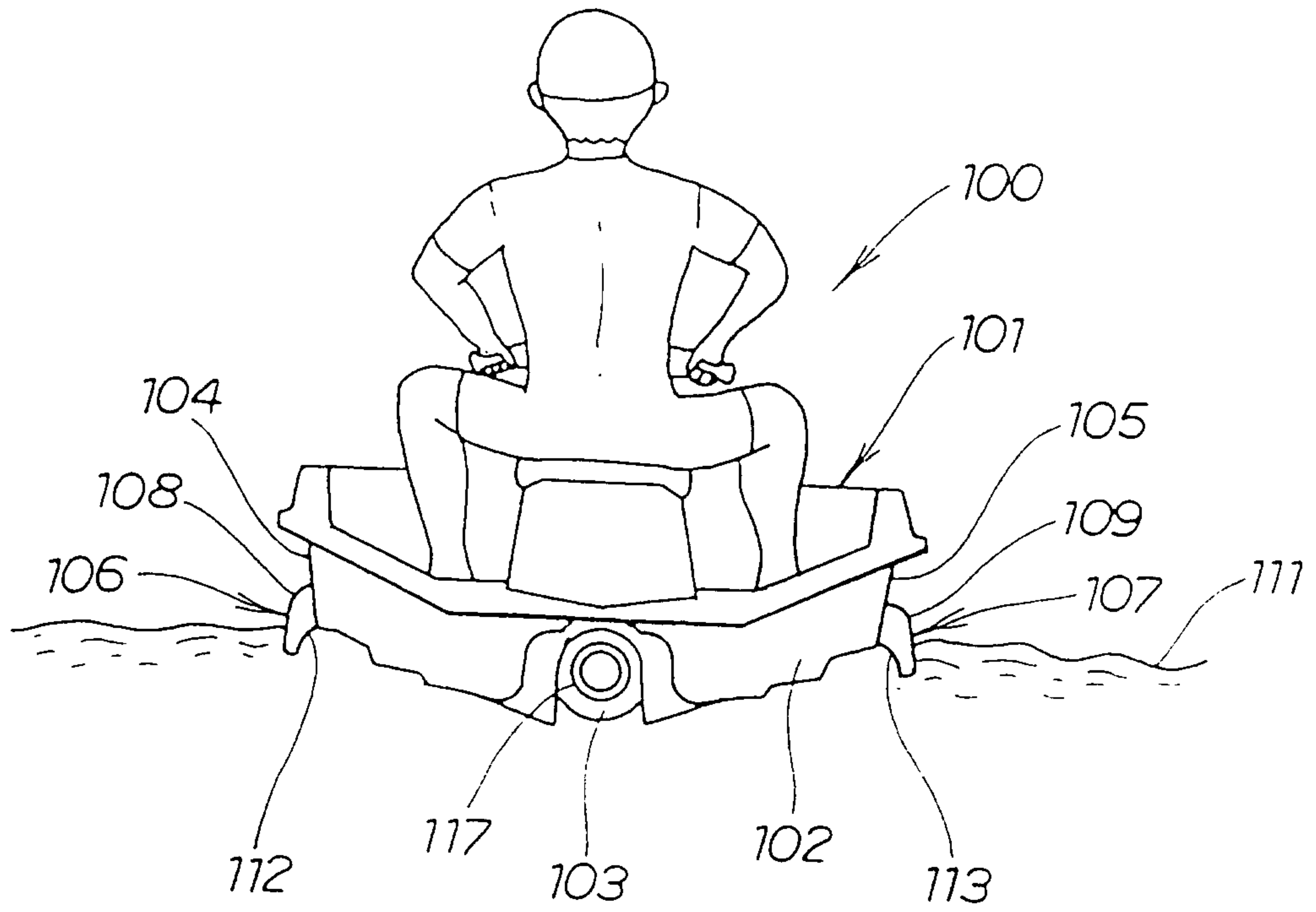
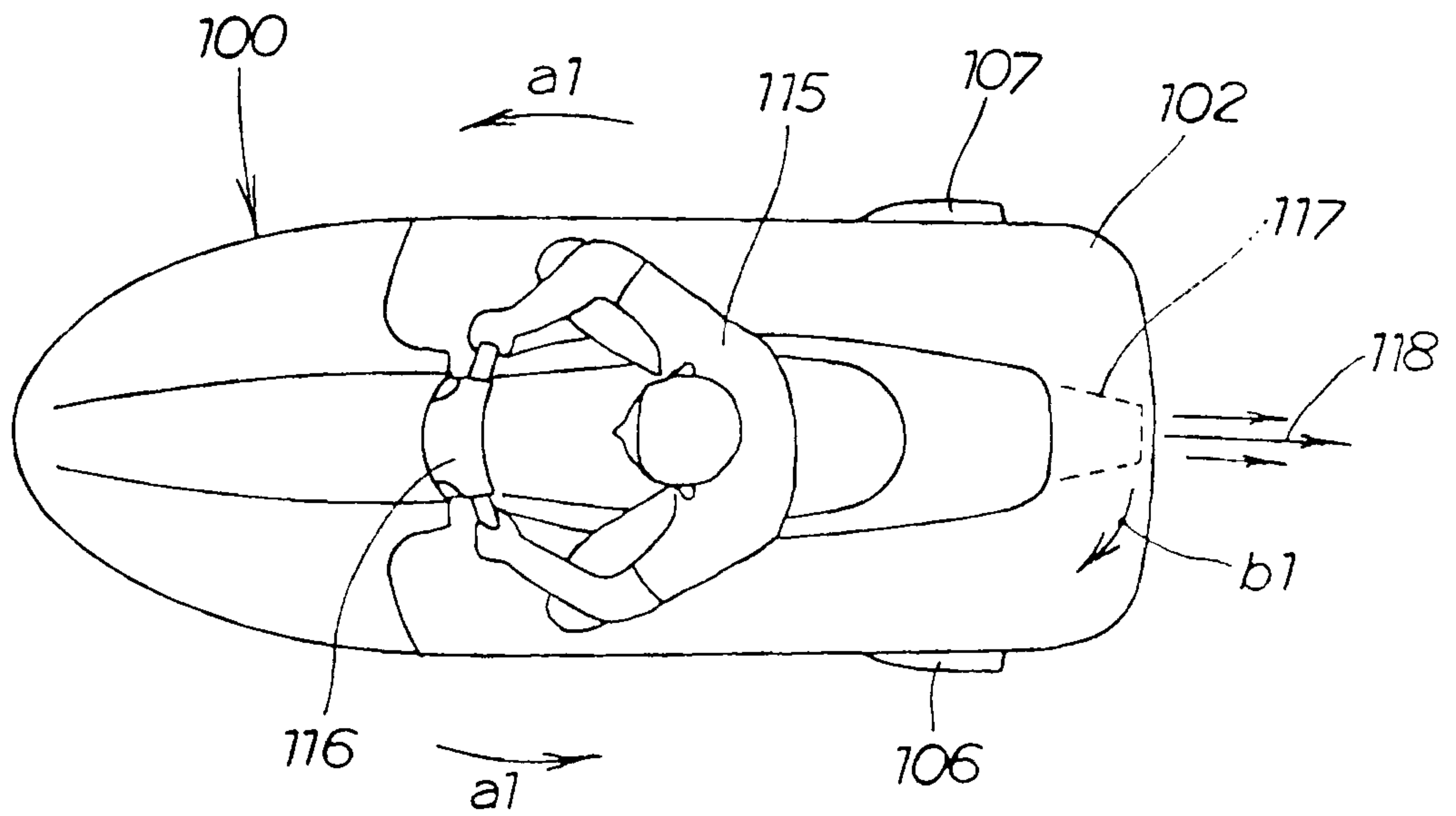

FIG. 10 (a)

PRIOR ART



(b)

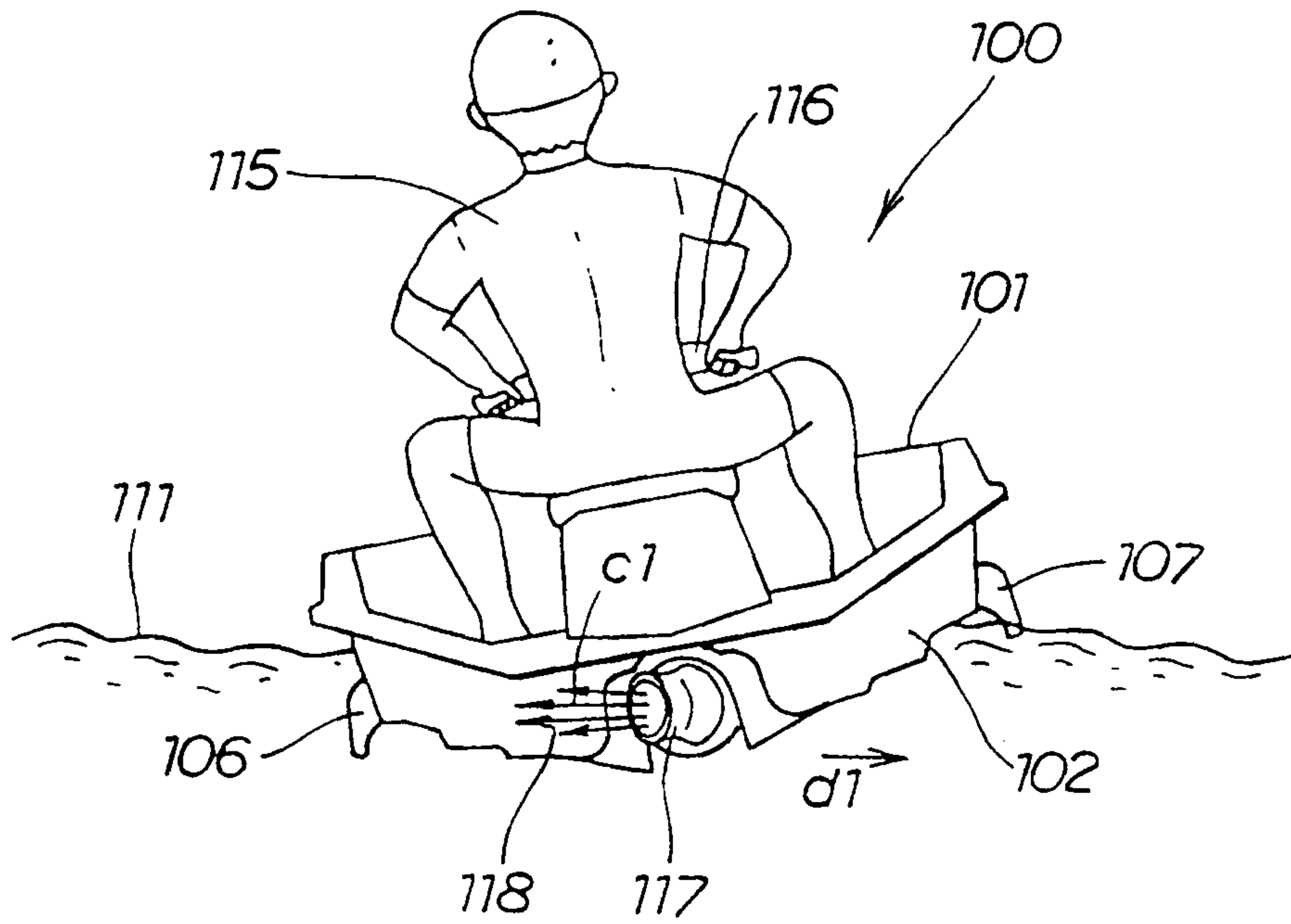

FIG. 11

PRIOR ART

