



INTERNATIONAL APPLICATION PUBLISHED UNDER THE PATENT COOPERATION TREATY (PCT)

<p>(51) International Patent Classification ⁵ : B29B 7/76</p>	<p>A1</p>	<p>(11) International Publication Number: WO 94/25238 (43) International Publication Date: 10 November 1994 (10.11.94)</p>
<p>(21) International Application Number: PCT/US94/04509 (22) International Filing Date: 29 April 1994 (29.04.94) (30) Priority Data: 08/057,034 5 May 1993 (05.05.93) US (71) Applicant: E.I. DU PONT DE NEMOURS AND COMPANY [US/US]; 1007 Market Street, Wilmington, DE 19898 (US). (72) Inventor: FALCOFF, Allan, Frohm; 14 Black Rock Road, Chadds Ford, PA 19317 (US). (74) Agents: McGEE, Patricia et al.; E.I. du Pont de Nemours and Company, Legal/Patent Records Center, 1007 Market Street, Wilmington, DE 19898 (US).</p>		<p>(81) Designated States: AU, BB, BG, BR, BY, CA, CN, CZ, FI, GE, HU, JP, KG, KP, KR, KZ, LK, LV, MD, MG, MN, MW, NO, NZ, PL, RO, RU, SD, SI, SK, TJ, TT, UA, UZ, VN, European patent (AT, BE, CH, DE, DK, ES, FR, GB, GR, IE, IT, LU, MC, NL, PT, SE), OAPI patent (BF, BJ, CF, CG, CI, CM, GA, GN, ML, MR, NE, SN, TD, TG).</p> <p>Published <i>With international search report.</i></p>

(54) Title: PRECISION LIQUID ADDITION DEVICE

(57) Abstract

An apparatus for delivering an accurate volume of fluid from a supply vessel to a process vessel or system in which a computer-controlled servo motor (30) and pump (18) means are connected with a modified sampling valve (22) with plunger-type injection means to allow complete addition of all metered fluids. The apparatus is particularly useful for addition of pH or viscosity control additives or shading colorants wherein the delivery of small volumes with precision is desired.

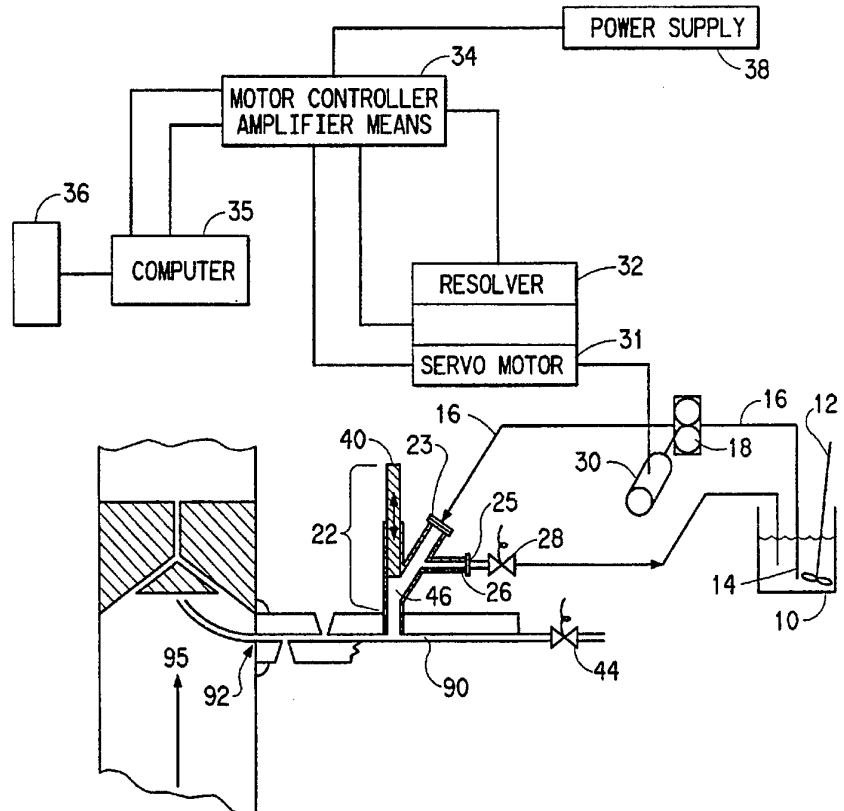

FOR THE PURPOSES OF INFORMATION ONLY

Codes used to identify States party to the PCT on the front pages of pamphlets publishing international applications under the PCT.

AT	Austria	GB	United Kingdom	MR	Mauritania
AU	Australia	GE	Georgia	MW	Malawi
BB	Barbados	GN	Guinea	NE	Niger
BE	Belgium	GR	Greece	NL	Netherlands
BF	Burkina Faso	HU	Hungary	NO	Norway
BG	Bulgaria	IE	Ireland	NZ	New Zealand
BJ	Benin	IT	Italy	PL	Poland
BR	Brazil	JP	Japan	PT	Portugal
BY	Belarus	KE	Kenya	RO	Romania
CA	Canada	KG	Kyrgystan	RU	Russian Federation
CF	Central African Republic	KP	Democratic People's Republic of Korea	SD	Sudan
CG	Congo	KR	Republic of Korea	SE	Sweden
CH	Switzerland	KZ	Kazakhstan	SI	Slovenia
CI	Côte d'Ivoire	LI	Liechtenstein	SK	Slovakia
CM	Cameroon	LK	Sri Lanka	SN	Senegal
CN	China	LU	Luxembourg	TD	Chad
CS	Czechoslovakia	LV	Latvia	TG	Togo
CZ	Czech Republic	MC	Monaco	TJ	Tajikistan
DE	Germany	MD	Republic of Moldova	TT	Trinidad and Tobago
DK	Denmark	MG	Madagascar	UA	Ukraine
ES	Spain	ML	Mali	US	United States of America
FI	Finland	MN	Mongolia	UZ	Uzbekistan
FR	France			VN	Viet Nam
GA	Gabon				

Yet another object of the invention is to eliminate dead or empty space within the system through a recirculation mode. Once the system is filled with materials to be added, the recirculation mode may be used to re-suspend materials within the fluid, such as pigments, and prevent inhomogeneity among the constituents.

SUMMARY OF THE INVENTION

The apparatus disclosed allows precise addition of fluids into a process vessel or process stream to make on-line ingredient additions or adjustments using a computer controlled servo motor and a modified sampling valve which contains plunger-type injection means to allow complete addition of all metered fluids. Fluids can be directly injected into the process or into a common manifold equipped with a chaser line to ensure that all addition material is flushed into the process.

The system has a closed-loop recirculation mode controlled by computer which allows the system to be purged of entrapped air in order to ensure that all material within the system is incompressible. The material within the system can also be recirculated periodically to prevent inhomogeneity for fluids with suspended material, such as a paint dispersion which contains pigment or metallic flake.

BRIEF DESCRIPTION OF THE DRAWINGS

FIG. 1 is a schematic representation illustrating the major components of the apparatus of the invention.

FIG. 2 is a schematic representation of a mode of direct injection.

DETAILED DESCRIPTION OF THE INVENTION

The apparatus of this invention is useful for delivering an accurate quantity of fluid from a supply vessel to a second vessel which usually is a mixing vessel. The apparatus is useful for addition of viscosity or pH control additives when mixing chemical components and is especially useful for mixing paints wherein the delivery of very small volumes with precision is essential.

FIG. 1 illustrates the apparatus in which an accurate volume of fluid is pumped from supply vessel 10 through injection port 22 and into product stream 95.

Supply vessel 10 contains fluids to be added to the system.

5 Agitating means 12 may be present to ensure suspension of solids within the liquids to be dispensed, such as pigments or metallic flake. Pipe 16 is positioned within supply vessel 10 such that inlet section 14 is below the surface of the fluids within supply vessel 10. Pipe 16 is connected by ordinary means to the inlet side of positive displacement means 18, typically, a pump
10 such as BarMag Model SV79A Gear Pump. Suitable examples of displacement means are a gear pump, piston pump or diaphragm pump.

Displacement means 18 is powered by servo motor 30, typically, an Industrial Motor, Model EB-202-A. Servo motor 30 is electrically attached to and controlled by a motor controller amplifier means
15 34, typically, an Industrial Drives Model BDS-5-203 Amplifier, driven by power supply 38, typically, Industrial Driver Model PSR-5-213, which is electrically coupled to computer 35. Resolver 33 connected to motor 30 measures the angular shaft rotation of motor 30 and feeds this information to motor controller amplifier means 34. Motor controller amplifier means 34
20 obtains rotation and velocity commands from computer 35 and signals computer 35 when the activity has been preformed.

Computer 35 is programmed to rotate servo motor 30 according to a pre-determined revolution-pump displacement relationship. Computer 30 calculates from in-process instrumentation or from
25 programmed input the number of rotations required to pump the desired amount of fluid from supply vessel 10 into process stream 95. From a predetermined relationship of motor revolutions relative to the volume of liquid displaced, computer 35 will download to the servo controller amplifier means 34 the number of revolutions necessary for servo motor 30 to
30 complete in order to displace the required volume of fluid.

The computer is typically a digital computer such as IBM, Intel 386-based personal computer. with an input through which formulation information is fed. The input can be a standard key board or another computer.

Pipe 16 extends from positive displacement means 18 to liquid injection valve 22 mounted by ordinary means on pipe 90. Liquid injection valve 22 is, typically, Sampling Valve SV-500, Strahman Valve, Inc. which has been modified with a second liquid port 26 drilled into standard side
5 port 23. Pipe 16 is attached to opening 25 of second liquid port 26 by ordinary means and pipe 16 returns to supply vessel 10. Automatic solenoid valve 28, typically, Quality Controls, Inc., Model SV-64-1/2, is mounted on pipe 16 in close proximity to second liquid injection port 26.

Liquid injection valve 22 has pneumatically controlled plunger
10 40, which can be positioned in either an open (up) or closed (down) position. When plunger 40 is in the open position, and solenoid valve 28 is closed, material from supply vessel 10 can enter pipe 16, be pumped through pipe 16 to enter process stream 95 through injection valve 22. When plunger 40 is closed and solenoid valve 28 is open, a closed loop system allows fluids in
15 supply vessel 10 to be pumped through pipe 16 without entering process stream 95.

In operation, supply vessel 10 is filled with fluids to be injected into process stream 95. Agitator means 12 may be used to assist in suspending solids present in such fluids, as typical in color dispersions. Computer 35
20 calculates the volume of fluids to be injected into process stream 95. From a predetermined relationship of motor revolutions to fluid volume displaced, computer 35 will download to servo motor control means 34 the number of motor revolutions necessary for servo motor 30 to complete. Computer 35 will signal plunger 40 to the open position and confirm that injection valve
25 22 is open. Computer 35 will then signal solenoid valve 28 to the closed position, confirm such closed position and start servo motor 30. Servo motor 30 will drive positive displacement means 18 the required number of revolutions to displace the desired volume of fluid. Upon completion of the pumping cycle computer 35 positions plunger 40 to the closed position. Any
30 fluid remaining in injection port cavity 46 will be injected into pipe 90 by the downward motion of plunger 40. This can also be manually operated at the end of the pumping sequence.

A chaser apparatus to wash fluids remaining in pipe 90 into process stream 95 is shown in FIG. 1. Electrically controlled solenoid valve
35 44 is mounted by ordinary means in close proximity to injection valve 22 on

pipe 90. As an alternative, manual means may be substituted for solenoid valve 44. Pipe 90 is connected to a supply of fluid, not shown, which is mutually miscible between the contents of supply vessel 10 and process stream 95. During injection, solenoid valve 44 is in a closed position. Upon completion of the injection, computer 35 directs solenoid valve 44 to an open position to allow an amount of the mutually miscible fluid to enter pipe 90 to flush any remaining fluids from supply vessel 10 out of pipe 90 and into process stream 95. Solenoid valve 44 is returned to the closed position by computer 35 after a suitable amount of time elapses. Care is taken to minimize the amount of flushing fluids entering pipe 90 so as to avoid degradation of process mixtures. A plurality of the described invention, in either a manifold or direct injection mode, can be attached to pipe 90 as to permit multiple injection options into the process stream. Materials can also be injected directly into the process stream or container in the absence of a manifold or chaser line, as seen in FIG. 2.

The system can also be in a recirculation mode. Computer 35 positions plunger 34 in a closed position to create a closed loop system. Fluids can then be pumped from supply vessel 10 through pipe 16 into modified sampling valve 23, through open solenoid valve 28 and return to supply vessel 10. Computer 35 will operate servo motor 30 for time intervals and speed levels such that sufficient volume of fluids within supply vessel 10 are pumped through the system at a velocity sufficient to displace air and resuspend any settled solids within the system, as prior to operation of the injection mode.

Recirculation can also be used to periodically cycle fluids containing suspended materials, such as paint dispersions which contain pigment or metallic flake, at sufficient velocities, such that settled pigment or solids are reincorporated into the fluid. Such recirculation will prevent inhomogeneity within the system. During such recirculation, plunger 40 being in the closed position will prevent valve cavity 40 from becoming filled or plugged with suspended materials.

Standard materials may be used to fabricate the components of the apparatus. Most components may be machined from aluminum, steel or stainless steel, depending on the properties of the fluids intended to pass through the apparatus.

When the apparatus is used in a typical paint mixing operation, all electrical equipment, such as motors, motor controller, valves and the like are modified to meet the specifications of Article 500 of The National Electrical Code for operation within electrically-classified
5 environments.

The disclosure and description of the invention are illustrative and explanatory thereof, and various changes in the size, shape and materials, as well as the details of the illustrated construction, may be made within the scope of the appended claims and without departing from the
10 spirit of the invention.

CLAIMS

What is claimed is:

- 5 1. An apparatus for delivering a controlled volume of fluid
from a supply vessel to a process stream which comprises:
- (a) at least one liquid supply vessel;
 - (b) a positive displacement means capable of delivering a
controlled volume of fluid from said supply vessel;
 - (c) controlling means coupled to said positive displacement
10 means which drives said positive displacement means;
 - (d) a computer capable of storing programs electrically connected
to said operating system;
 - (e) a injection valve having three injection ports, wherein the first
port receives fluid from said supply vessel, the second port
15 allows said fluid to flow out of said injection valve into a
process line and a third port which allows fluid to flow to a
recirculation line;
 - (f) a plunger in said injection valve being positioned within said
injection valve such that fluid may enter the space within said
20 injection valve, said plunger acting as a syringe to perform
complete addition of materials at the completion of the
pumping cycle;
 - (g) a solenoid controlled by the computer to a position to allow
circulation of fluids from said supply vessel through said
25 injection valve back to said supply vessel;

wherein said computer through the motor controller means activates the
motor which drives the positive displacement means to pump a volume of
fluid from said supply vessel into said injection valve as the plunger is in the
open position such that pumped fluids enter said process stream.

- 30 2. Apparatus as claimed in claim 1 wherein said computer is
a digital computer.
3. Apparatus as claimed in claim 1 wherein said computer
35 has a keyboard input or has input from a second computer.

4. Apparatus as claimed in claim 1 wherein said controlling system is

- 5
- (a) a servo motor connected to said displacement means;
 - (b) a resolver connected to said servo motor for measuring angular rotation and motor speed of displacement means within said motor; and
 - (c) a motor controller amplifier means electrically connected to said resolver which receives a signal on angular rotation from said resolver and thereby computes motor speed to control the motor and output of said positive displacement means.
- 10

5. An apparatus for delivering an accurate volume of fluid from a supply vessel to a process stream which comprises:

- 15
- (a) at least one liquid supply vessel;
 - (b) a positive displacement means capable of pumping an accurate volume of fluid from said supply vessel;
 - (c) controlling means coupled to said positive displacement means which drives said positive displacement means;
 - (d) a computer capable of storing programs electrically connected to said operating system;
 - (e) an injection valve having three injection ports, wherein the first port receives fluid from said supply vessel, the second port allows said fluid to flow out of said injection valve into a process line and a third port which allows fluid to flow to a recirculation line;
 - (f) a plunger in said injection valve being positioned within said injection valve such that fluid may enter the space within said injection valve, said plunger acting as a syringe to perform complete addition of materials at the completion of the pumping cycle;
 - (g) a solenoid controlled by the computer to allow circulation of fluids from said supply vessel through said injection valve back to said supply vessel;
- 20
- 25
- 30

(h) a conduit which carries fluids to flush a supply line whose flow is controlled by a solenoid controlled by said computer; wherein said computer through the motor controller means activates the motor which drives the positive displacement means to pump a volume of fluid from said supply vessel into said injection valve as the plunger is in the open position such that pumped fluids enter said process stream, said plunger returns to said closed position, said second solenoid opening to allow fluids from said conduit to enter.

10 6. Apparatus as claimed in claim 4 wherein said computer is a digital computer.

7. Apparatus as claimed in claim 4 wherein said controlling means is

15 (a) a servo motor connected to said displacement means;
 (b) a resolver connected to the motor for measuring angular rotation of displacement means within said motor; and
 (c) a motor controller amplifier means electrically connected to a resolver which receives a signal on angular rotation from said
20 resolver and thereby controls the motor and output of said positive displacement means.

FIG. 1

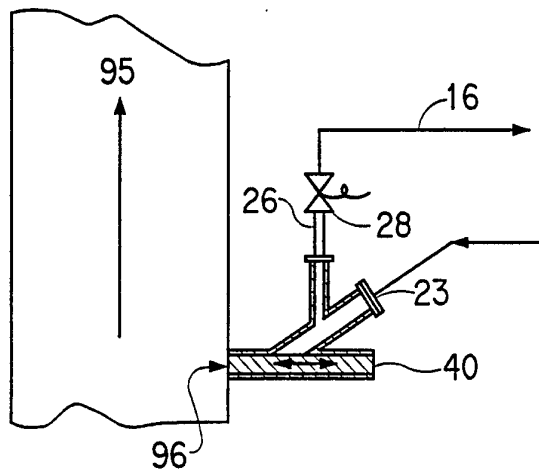
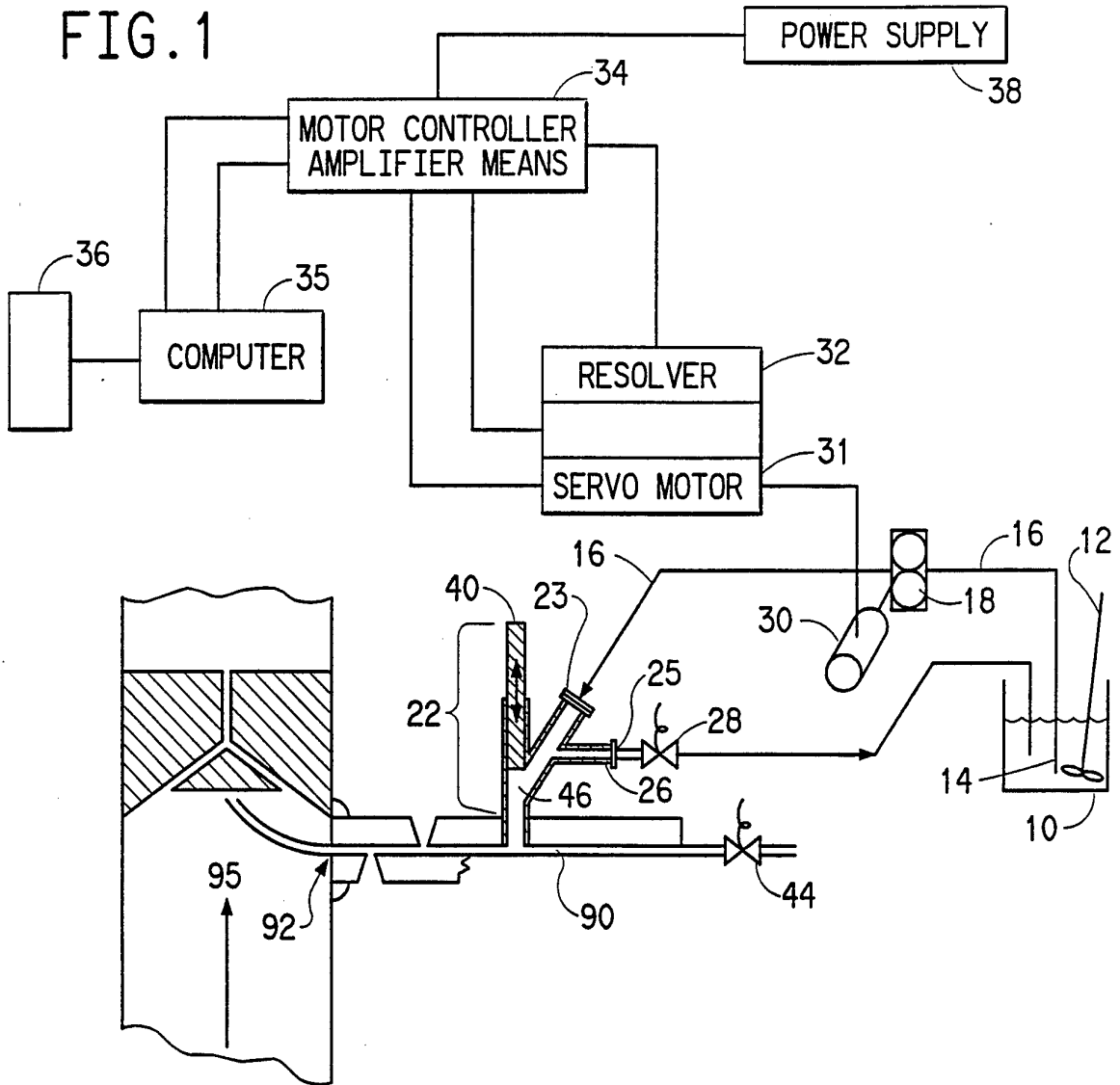

FIG. 2

INTERNATIONAL SEARCH REPORT

International Application No
PCT/US 94/04509

A. CLASSIFICATION OF SUBJECT MATTER
IPC 5 B29B7/76

According to International Patent Classification (IPC) or to both national classification and IPC

B. FIELDS SEARCHED

Minimum documentation searched (classification system followed by classification symbols)
IPC 5 B29B B01F

Documentation searched other than minimum documentation to the extent that such documents are included in the fields searched

Electronic data base consulted during the international search (name of data base and, where practical, search terms used)

C. DOCUMENTS CONSIDERED TO BE RELEVANT

Category *	Citation of document, with indication, where appropriate, of the relevant passages	Relevant to claim No.
X	WO,A,91 10551 (HENDERSON) 25 July 1991 ---	1-7
X	EP,A,0 025 844 (BAYER) 1 April 1981 ---	1,5
X	EP,A,0 025 871 (BAYER) 1 April 1981 ---	1,5
A	EP,A,0 494 453 (NORDSON) 15 July 1992 ---	4,7
A	US,A,4 399 105 (TILGNER) 16 August 1983 ---	2,3,6
A	FR,A,2 391 838 (BAYER) 22 December 1978 -----	

Further documents are listed in the continuation of box C.

Patent family members are listed in annex.

* Special categories of cited documents :

- *A* document defining the general state of the art which is not considered to be of particular relevance
- *E* earlier document but published on or after the international filing date
- *L* document which may throw doubts on priority claim(s) or which is cited to establish the publication date of another citation or other special reason (as specified)
- *O* document referring to an oral disclosure, use, exhibition or other means
- *P* document published prior to the international filing date but later than the priority date claimed

- *T* later document published after the international filing date or priority date and not in conflict with the application but cited to understand the principle or theory underlying the invention
- *X* document of particular relevance; the claimed invention cannot be considered novel or cannot be considered to involve an inventive step when the document is taken alone
- *Y* document of particular relevance; the claimed invention cannot be considered to involve an inventive step when the document is combined with one or more other such documents, such combination being obvious to a person skilled in the art.
- *&* document member of the same patent family

Date of the actual completion of the international search

20 July 1994

Date of mailing of the international search report

09. 08. 94

Name and mailing address of the ISA

European Patent Office, P.B. 5818 Patentlaan 2
NL - 2280 HV Rijswijk
Tel. (+ 31-70) 340-2040, Tx. 31 651 epo nl,
Fax (+ 31-70) 340-3016

Authorized officer

Peeters, S

INTERNATIONAL SEARCH REPORT

Information on patent family members

International Application No

PCT/US 94/04509

Patent document cited in search report	Publication date	Patent family member(s)	Publication date
WO-A-9110551	25-07-91	EP-A- 0593451	27-04-94
EP-A-0025844	01-04-81	DE-A- 2933327 AT-T- 2306 JP-A- 56030832 US-A- 4288230	26-03-81 15-02-83 28-03-81 08-09-81
EP-A-0025871	01-04-81	DE-A- 2936223 AT-T- 2883 JP-C- 1474486 JP-A- 56044640 JP-B- 63023891 US-A- 4399104 US-A- 4448902	19-03-81 15-04-83 18-01-89 23-04-81 18-05-88 16-08-83 15-05-84
EP-A-0494453	15-07-92	US-A- 5152426 AU-B- 644930 AU-A- 1010092 CA-A- 2057948 JP-A- 6088741 US-A- 5271521	06-10-92 23-12-93 16-07-92 12-07-92 29-03-94 21-12-93
US-A-4399105	16-08-83	NONE	
FR-A-2391838	22-12-78	DE-A- 2724132 GB-A- 1600166 JP-A- 53147795 US-A- 4195527	30-11-78 14-10-81 22-12-78 01-04-80