

(12) PATENT ABRIDGMENT (11) Document No. AU-B-41659/89
(19) AUSTRALIAN PATENT OFFICE (10) Acceptance No. 623681

(54) Title
A METHOD FOR FORMING A METAL COMPOSITE BODY BY AN OUTSIDE-IN SPONTANEOUS INFILTRATION PROCESS, AND PRODUCTS PRODUCED THEREBY

International Patent Classification(s)
(51)^d **B22D 019/14 C04B 041/88 C22C 001/09 C22C 001/10**

(21) Application No. : **41659/89** (22) Application Date : **22.09.89**

(30) Priority Data

(31) Number (32) Date (33) Country
269370 10.11.88 US UNITED STATES OF AMERICA

(43) Publication Date : **17.05.90**

(44) Publication Date of Accepted Application : **21.05.92**

(71) Applicant(s)
LANXIDE CORPORATION

(72) Inventor(s)
RATNESH KUMAR DWIVEDI

(74) Attorney or Agent
DAVIES COLLISON CAVE , 1 Little Collins Street, MELBOURNE VIC 3000

(56) Prior Art Documents
US 4828008
US 4718941
US 3364976

(57) Claim

1. A method for making a metal matrix composite, comprising:

providing a substantially non-reactive filler, said filler including a cavity portion therein;

communicating a localized infiltrating atmosphere with at least a portion of said cavity in said filler;

providing at least one of an infiltration enhancer precursor and an infiltration enhancer; and

spontaneously infiltrating at least a portion of the filler with molten matrix metal.

12. The method of claim 1, further comprising the step of defining a surface boundary of the filler with a barrier, wherein the matrix metal spontaneously infiltrates up to the barrier.

13. The method of claim 12, wherein the barrier comprises a material selected from the group consisting of carbon, graphite and titanium diboride.

16. The method of claim 1, wherein the filler comprises at least one material selected from the group consisting of powders, flakes, platelets, microspheres, whiskers, bubbles, fibers, particulates, fiber

(11) AU-B-41659/89
(10) 623681

-2-

mats, chopped fibers, spheres, pellets, tubules and refractory cloths.

19. The method of claim 1, wherein the matrix metal comprises aluminum, the infiltration enhancer precursor comprises at least one material selected from the group consisting of magnesium, strontium and calcium, and the infiltrating atmosphere comprises nitrogen.

20. The method of claim 1, wherein the matrix metal comprises aluminum, the infiltration enhancer precursor comprises zinc, and the infiltrating atmosphere comprises oxygen.

29. The method of claim 1, wherein the matrix metal comprises aluminum and the filler comprises at least one material selected from the group consisting of oxides, carbides, borides and nitrides.

623681

COMMONWEALTH OF AUSTRALIA
PATENTS ACT 1952
COMPLETE SPECIFICATION

NAME & ADDRESS
OF APPLICANT:

Lanxide Corporation
Tralee Industrial Park
Newark Delaware 19714-6077
United States of America

NAME(S) OF INVENTOR(S):

Ratnesh Kumar DWIVEDI

ADDRESS FOR SERVICE:

DAVIES & COLLISON
Patent Attorneys
1 Little Collins Street, Melbourne, 3000.

COMPLETE SPECIFICATION FOR THE INVENTION ENTITLED:

A method for forming a metal composite body by an outside-in spontaneous infiltration process, and products produced thereby

The following statement is a full description of this invention, including the best method of performing it known to me/us:-

Field of the Invention

The present invention relates to a novel method for forming metal matrix composites, and products produced thereby. Particularly, a permeable mass of filler material is formed into a preform, the preform containing a cavity in at least a portion thereof. An infiltration enhancer and/or an infiltration enhancer precursor and/or an infiltrating atmosphere are also in communication with the preform, at least at some point during the process, which permits molten matrix metal to spontaneously infiltrate the preform when the preform is placed into molten matrix metal. The infiltrating atmosphere should communicate at least with the cavity in the preform for at least a portion of the process. Moreover, when molten matrix metal is contacted with an exterior portion of the preform, the molten matrix metal will spontaneously infiltrate the preform from an exterior surface thereof toward the cavity therein.

20 Background of the Invention

Composite products comprising a metal matrix and a strengthening or reinforcing phase such as ceramic particulates, whiskers, fibers or the like, show great promise for a variety of applications because they combine some of the stiffness and wear resistance of the reinforcing phase with the ductility and toughness of the metal matrix. Generally, a metal matrix composite will show an improvement in such properties as strength, stiffness, contact wear resistance, and elevated temperature strength retention relative to the matrix metal in monolithic form, but the degree to which any given property may be improved depends largely on the

specific constituents, their volume or weight fraction, and how they are processed in forming the composite. In some instances, the composite also may be lighter in weight than the matrix metal per se. Aluminum matrix composites reinforced with ceramics such as silicon carbide in particulate, platelet, or whisker form, for example, are of interest because of their higher stiffness, wear resistance and high temperature strength relative to aluminum.

Various metallurgical processes have been described for the fabrication of aluminum matrix composites, including methods based on powder metallurgy techniques and liquid-metal infiltration techniques which make use of pressure casting, vacuum casting, stirring, and wetting agents. With powder metallurgy techniques, the metal in the form of a powder and the reinforcing material in the form of a powder, whiskers, chopped fibers, etc., are admixed and then either cold-pressed and sintered, or hot-pressed. The maximum ceramic volume fraction in silicon carbide reinforced aluminum matrix composites produced by this method has been reported to be about 25 volume percent in the case of whiskers, and about 40 volume percent in the case of particulates.

The production of metal matrix composites by powder metallurgy techniques utilizing conventional processes imposes certain limitations with respect to the characteristics of the products attainable. The volume fraction of the ceramic phase in the composite is limited typically, in the case of particulates, to about 40 percent. Also, the pressing operation poses a limit on the practical size attainable. Only relatively simple product shapes are possible without subsequent processing (e.g., forming or machining) or without resorting to complex presses. Also, nonuniform shrinkage during sintering can occur, as well as nonuniformity of

microstructure due to segregation in the compacts and grain growth.

U.S. Patent No. 3,970,136, granted July 20, 1976, to J. C. Cannell et al., describes a process for forming a
5 metal matrix composite incorporating a fibrous
reinforcement, e.g. silicon carbide or alumina whiskers,
having a predetermined pattern of fiber orientation. The
composite is made by placing parallel mats or felts of
10 coplanar fibers in a mold with a reservoir of molten
matrix metal, e.g., aluminum, between at least some of the
mats, and applying pressure to force molten metal to
penetrate the mats and surround the oriented fibers.
Molten metal may be poured onto the stack of mats while
being forced under pressure to flow between the mats.
15 Loadings of up to about 50% by volume of reinforcing
fibers in the composite have been reported.

The above-described infiltration process, in view of its dependence on outside pressure to force the molten matrix metal through the stack of fibrous mats, is subject
20 to the vagaries of pressure-induced flow processes, i.e., possible non-uniformity of matrix formation, porosity, etc. Non-uniformity of properties is possible even though molten metal may be introduced at a multiplicity of sites within the fibrous array. Consequently, complicated mat/
25 reservoir arrays and flow pathways need to be provided to achieve adequate and uniform penetration of the stack of fiber mats. Also, the aforesaid pressure-infiltration method allows for only a relatively low reinforcement to matrix volume fraction to be achieved because of the
30 difficulty inherent in infiltrating a large mat volume. Still further, molds are required to contain the molten metal under pressure, which adds to the expense of the process. Finally, the aforesaid process, limited to infiltrating aligned particles or fibers, is not directed
35 to formation of aluminum metal matrix composites

reinforced with materials in the form of randomly oriented particles, whiskers or fibers.

In the fabrication of aluminum matrix-alumina filled composites, aluminum does not readily wet alumina, thereby making it difficult to form a coherent product. Various solutions to this problem have been suggested. One such approach is to coat the alumina with a metal (e.g., nickel or tungsten), which is then hot-pressed along with the aluminum. In another technique, the aluminum is alloyed with lithium, and the alumina may be coated with silica. However, these composites exhibit variations in properties, or the coatings can degrade the filler, or the matrix contains lithium which can affect the matrix properties.

U.S. Patent No. 4,232,091 to R. W. Grimshaw et al., overcomes certain difficulties in the art which are encountered in the production of aluminum matrix-alumina composites. This patent describes applying pressures of 75-375 kg/cm² to force molten aluminum (or molten aluminum alloy) into a fibrous or whisker mat of alumina which has been preheated to 700 to 1050°C. The maximum volume ratio of alumina to metal in the resulting solid casting was 0.25/1. Because of its dependency on outside force to accomplish infiltration, this process is subject to many of the same deficiencies as that of Cannell et al.

European Patent Application Publication No. 115,742 describes making aluminum-alumina composites, especially useful as electrolytic cell components, by filling the voids of a preformed alumina matrix with molten aluminum. The application emphasizes the non-wettability of alumina by aluminum, and therefore various techniques are employed to wet the alumina throughout the preform. For example, the alumina is coated with a wetting agent of a diboride of titanium, zirconium, hafnium, or niobium, or with a metal, i.e., lithium, magnesium, calcium, titanium,

chromium, iron, cobalt, nickel, zirconium, or hafnium. Inert atmospheres, such as argon, are employed to facilitate wetting. This reference also shows applying pressure to cause molten aluminum to penetrate an uncoated matrix. In this aspect, infiltration is accomplished by 5 evacuating the pores and then applying pressure to the molten aluminum in an inert atmosphere, e.g., argon. Alternatively, the preform can be infiltrated by vapor-phase aluminum deposition to wet the surface prior 10 to filling the voids by infiltration with molten aluminum. To assure retention of the aluminum in the pores of the preform, heat treatment, e.g., at 1400 to 1800°C, in either a vacuum or in argon is required. Otherwise, either exposure of the pressure infiltrated material to 15 gas or removal of the infiltration pressure will cause loss of aluminum from the body.

The use of wetting agents to effect infiltration of an alumina component in an electrolytic cell with molten metal is also shown in European Patent Application 20 Publication No. 94353. This publication describes production of aluminum by electrowinning with a cell having a cathodic current feeder as a cell liner or substrate. In order to protect this substrate from molten cryolite, a thin coating of a mixture of a wetting agent 25 and solubility suppressor is applied to the alumina substrate prior to start-up of the cell or while immersed in the molten aluminum produced by the electrolytic process. Wetting agents disclosed are titanium, zirconium, hafnium, silicon, magnesium, vanadium, 30 chromium, niobium, or calcium, and titanium is stated as the preferred agent. Compounds of boron, carbon and nitrogen are described as being useful in suppressing the solubility of the wetting agents in molten aluminum. The reference, however, does not suggest the production of 35 metal matrix composites, nor does it suggest the formation

of such a composite in, for example, a nitrogen atmosphere.

In addition to application of pressure and wetting agents, it has been disclosed that an applied vacuum will
5 aid the penetration of molten aluminum into a porous ceramic compact. For example, U.S. Patent No. 3,718,441, granted February 27, 1973, to R. L. Landingham, reports infiltration of a ceramic compact (e.g., boron carbide, alumina and beryllia) with either molten aluminum,
10 beryllium, magnesium, titanium, vanadium, nickel or chromium under a vacuum of less than 10^{-6} torr. A vacuum of 10^{-2} to 10^{-6} torr resulted in poor wetting of the ceramic by the molten metal to the extent that the metal did not flow freely into the ceramic void spaces.
15 However, wetting was said to have improved when the vacuum was reduced to less than 10^{-6} torr.

U.S. Patent No. 3,864,154, granted February 4, 1975, to G. E. Gazza et al., also shows the use of vacuum to achieve infiltration. This patent describes loading a
20 cold-pressed compact of AlB_{12} powder onto a bed of cold-pressed aluminum powder. Additional aluminum was then positioned on top of the AlB_{12} powder compact. The crucible, loaded with the AlB_{12} compact "sandwiched" between the layers of aluminum powder, was placed in a
25 vacuum furnace. The furnace was evacuated to approximately 10^{-5} torr to permit outgassing. The temperature was subsequently raised to $1100^{\circ}C$ and maintained for a period of 3 hours. At these conditions, the molten aluminum penetrated the porous AlB_{12} compact.

U.S. Patent No. 3,364,976, granted January 23, 1968
30 to John N. Reding et al., discloses the concept of creating a self-generated vacuum in a body to enhance penetration of a molten metal into the body. Specifically, it is disclosed that a body, e.g., a
35 graphite mold, a steel mold, or a porous refractory

material, is entirely submerged in a molten metal. In the case of a mold, the mold cavity, which is filled with a gas reactive with the metal, communicates with the externally located molten metal through at least one
5 orifice in the mold. When the mold is immersed into the melt, filling of the cavity occurs as the self-generated vacuum is produced from the reaction between the gas in the cavity and the molten metal. Particularly, the vacuum is a result of the formation of a solid oxidized form of
10 the metal. Thus, Reding et al. disclose that it is essential to induce a reaction between gas in the cavity and the molten metal. However, utilizing a mold to create a vacuum may be undesirable because of the inherent limitations associated with use of a mold. Molds must
15 first be machined into a particular shape; then finished, machined to produce an acceptable casting surface on the mold; then assembled prior to their use; then disassembled after their use to remove the cast piece therefrom; and thereafter reclaim the mold, which most likely would
20 include refinishing surfaces of the mold or discarding the mold if it is no longer acceptable for use. Machining of a mold into a complex shape can be very costly and time-consuming. Moreover, removal of a formed piece from a complex-shaped mold can also be difficult (i.e., cast
25 pieces having a complex shape could be broken when removed from the mold). Still further, while there is a suggestion that a porous refractory material can be immersed directly in a molten metal without the need for a mold, the refractory material would have to be an integral
30 piece because there is no provision for infiltrating a loose or separated porous material absent the use of a container mold (i.e., it is generally believed that the particulate material would typically disassociate or float apart when placed in a molten metal). Still further, if
35 it was desired to infiltrate a particulate material or

loosely formed preform, precautions should be taken so that the infiltrating metal does not displace at least portions of the particulate or preform resulting in a non-homogeneous microstructure.

5 Accordingly, there has been a long felt need for a simple and reliable process to produce shaped metal matrix composites which does not rely upon the use of applied pressure or vacuum (whether externally applied or internally created), or damaging wetting agents to create
10 a metal matrix embedding another material such as a ceramic material. Moreover, there has been a long felt need to minimize the amount of final machining operations needed to produce a metal matrix composite body. The present invention satisfies these needs by providing a
15 spontaneous infiltration mechanism for infiltrating a material (e.g., a ceramic material), which can be formed into a preform, with molten matrix metal (e.g., aluminum) in the presence of an infiltrating atmosphere (e.g., nitrogen) under normal atmospheric pressures so long as an
20 infiltration enhancer is present at least at some point during the process.

Description of Commonly Owned U.S. Patent Applications

25 The subject matter of this application is related to that of several other copending and co-owned patent applications. Particularly, these other copending patent applications describe novel methods for making metal matrix composite materials (hereinafter sometimes referred to as "Commonly Owned Metal Matrix Patent Applications").

30 A novel method of making a metal matrix composite material is disclosed in ^{Australian Patent Application 16367/88 which corresponds to} Commonly Owned U.S. Patent Application Serial No. 049,171, filed May 13, 1987, in the names of White et al., and entitled "Metal Matrix Composites", now allowed in the United States. According
35 to the method of the White et al. invention, a metal



matrix composite is produced by infiltrating a permeable mass of filler material (e.g., a ceramic or a ceramic-coated material) with molten aluminum containing at least about 1 percent by weight magnesium, and preferably at least about 3 percent by weight magnesium. Infiltration occurs spontaneously without the application of external pressure or vacuum. A supply of the molten metal alloy is contacted with the mass of filler material at a temperature of at least about 675°C in the presence of a gas comprising from about 10 to 100 percent, and preferably at least about 50 percent, nitrogen by volume, and a remainder of the gas, if any, being a nonoxidizing gas, e.g., argon. Under these conditions, the molten aluminum alloy infiltrates the ceramic mass under normal atmospheric pressures to form an aluminum (or aluminum alloy) matrix composite. When the desired amount of filler material has been infiltrated with the molten aluminum alloy, the temperature is lowered to solidify the alloy, thereby forming a solid metal matrix structure that embeds the reinforcing filler material. Usually, and preferably, the supply of molten alloy delivered will be sufficient to permit the infiltration to proceed essentially to the boundaries of the mass of filler material. The amount of filler material in the aluminum matrix composites produced according to the White et al. invention may be exceedingly high. In this respect, filler to alloy volumetric ratios of greater than 1:1 may be achieved.

Under the process conditions in the aforesaid White et al. invention, aluminum nitride can form as a discontinuous phase dispersed throughout the aluminum matrix. The amount of nitride in the aluminum matrix may vary depending on such factors as temperature, alloy composition, gas composition and filler material. Thus, by controlling one or more such factors in the system, it

is possible to tailor certain properties of the composite. For some end use applications, however, it may be desirable that the composite contain little or substantially no aluminum nitride.

5 It has been observed that higher temperatures favour infiltration but render the process more conducive to nitride formation. The White et al. invention allows the choice of a balance between infiltration kinetics and nitride formation.

10 An example of suitable barrier means for use with metal matrix composite formation is described in Commonly Owned and Copending Australian Patent Application 26439/88 which corresponds to U.S. Patent Application Serial No. 141,642, filed January 7, 1988, in the names
15 of Michael K. Aghajanian et al., and entitled "Method of Making Metal Matrix Composite with the use of a Barrier". According to the method of this Aghajanian et al. invention a barrier means (e.g., particulate titanium diboride or a graphite material such as a flexible
20 graphite tape product sold by Union Carbide under the trade name Grafoil®) is disposed on a defined surface boundary of a filler material and matrix alloy infiltrates up to the boundary defined by the barrier means. The barrier means is used to inhibit, prevent, or
25 terminate infiltration of the molten alloy, thereby providing net, or near net, shapes in the resultant metal matrix composite. Accordingly, the formed metal matrix composite bodies have an outer shape which substantially corresponds to the inner shape of the barrier means.

30 The method of Australian Patent Application 16367/88 was improved upon by Commonly Owned and Copending European Patent Application 333629 published 20 September, 1989. In accordance with the methods disclosed in this European Patent Application, a

35



matrix metal alloy is present as a first source of metal and as a reservoir of matrix metal alloy which communicates with the first source of molten metal due to, for example, gravity flow. Particularly, under the

5 conditions described in this patent application, the first source of molten matrix alloy begins to infiltrate the mass of filler material under normal atmospheric pressures and thus begins the formation of a metal matrix composite. The first source of molten matrix metal alloy is consumed

10 during its infiltration into the mass of filler material and, if desired, can be replenished, preferably by a continuous means, from the reservoir of molten matrix metal as the spontaneous infiltration continues. When a desired amount of permeable filler has been spontaneously

15 infiltrated by the molten matrix alloy, the temperature is lowered to solidify the alloy, thereby forming a solid metal matrix structure that embeds the reinforcing filler material. It should be understood that the use of a reservoir of metal is simply one embodiment of the

20 invention described in this patent application and it is not necessary to combine the reservoir embodiment with each of the alternate embodiments of the invention disclosed therein, some of which could also be beneficial to use in combination with the present invention.

25 The reservoir of metal can be present in an amount such that it provides for a sufficient amount of metal to infiltrate the permeable mass of filler material to a predetermined extent. Alternatively, an optional barrier means can contact the permeable mass of filler on at least

30 one side thereof to define a surface boundary.

Moreover, while the supply of molten matrix alloy delivered should be at least sufficient to permit spontaneous infiltration to proceed essentially to the boundaries (e.g., barriers) of the permeable mass of

35 filler material, the amount of alloy present in the

reservoir could exceed such sufficient amount so that not only will there be a sufficient amount of alloy for complete infiltration, but excess molten metal alloy could remain and be attached to the metal matrix

5 composite body. Thus, when excess molten alloy is present, the resulting body will be a complex composite body (e.g., a macrocomposite), wherein an infiltrated ceramic body having a metal matrix therein will be directly bonded to excess metal remaining in the
10 reservoir.

Each of the above-discussed related Australian and European Metal Matrix Patent Applications describes methods for the production of metal matrix composite bodies and novel metal matrix composite bodies which are
15 produced therefrom. The entire disclosures of all of the foregoing Commonly Owned Metal Matrix Patent Applications are expressly incorporated herein by reference.

Summary of the Invention

A metal matrix composite body is produced by
20 spontaneously infiltrating a permeable mass of filler material which may be formed into and for convenience will hereinafter be referred to as a preform, said preform including, at least in a portion thereof, a cavity. Specifically, a matrix metal is made molten and
25 the matrix metal may be held within an appropriate non-reactive vessel for housing matrix metal (e.g., a suitable refractory container) to form a body of molten matrix metal. The preform containing the cavity can be placed, for example at least partially into the molten
30 matrix metal, such that an infiltrating atmosphere can communicate with the cavity in the preform for at least a portion of the process, in order to obtain spontaneous infiltration of molten matrix metal, for example, from an exterior surface of the preform toward the cavity
35 therein.

More specifically, an infiltration enhancer and/or an infiltration enhancer precursor communicate with the



preform, at least at some point during the process, which permits or induces molten matrix metal to spontaneously infiltrate the preform, ^{for example,} when an exterior surface of the preform is placed into at least partial contact with
5 molten matrix metal. Thus, molten matrix metal can infiltrate the preform from an outside surface thereof towards the cavity, thus producing a metal matrix composite body having substantially the geometry of the preform.

10 In a preferred embodiment, an infiltrating atmosphere is substantially continuously supplied to a cavity or interior portion in a preform. An exterior portion or surface of the preform is exposed to molten matrix metal. The substantially simultaneous exposure of
15 the cavity in the preform to an infiltrating atmosphere and exposure of the exterior surface of the preform to molten matrix metal causes the molten matrix metal to spontaneously infiltrate the preform, so long as an infiltration enhancer precursor and/or an infiltration
20 enhancer are also provided to the spontaneous system in at least one of the matrix metal and/or the preform and/or the infiltrating atmosphere.

In a further preferred embodiment, prior to
immersing in molten matrix metal a cylindrical or tubular
25 shaped preform which does not contain a natural cavity, a temporary cavity is formed in the preform. Particularly, for example, an open end of the preform which is to be immersed into molten matrix metal can be plugged with an appropriate plugging means. Such plugging means serves to
30 create a temporary cavity in the preform. Accordingly, the temporary cavity can accept and maintain an infiltrating atmosphere for a requisite amount of time. The plugging means may comprise a material which is substantially non-reactive with each of, or at least one
35 of, the matrix metal and/or the preform and/or the



infiltrating atmosphere and/or the infiltration enhancer and/or the infiltration enhancer precursor. Once such a preform includes a plugging means therein to create a temporary cavity, molten matrix metal may spontaneously
5 infiltrate the preform from an exterior surface thereof toward the temporary cavity.

In another preferred embodiment, in a naturally formed cavity in a preform, or in a temporary cavity which is formed by the use of a plugging means, further
10 includes, at another portion thereof, a restricting means which restricts or reduces the communication of the cavity in the preform with any non-infiltrating atmosphere which may be present. Particularly, in order to create a more confined or self-contained atmosphere within a naturally
15 occurring cavity or a temporary cavity, an open end of the preform is at least partially restricted or closed so that infiltrating atmosphere which is to flow into the cavity is restricted from escaping and/or any non-infiltrating atmosphere (e.g., an oxidant) may be restricted from
20 communicating with the cavity. The use of said restricting means in the preform may assist molten matrix metal to spontaneously infiltrate the preform from an exterior portion of the preform toward the cavity in the preform.

25 In a still further preferred embodiment, an oxidant gatherer may be placed into a natural cavity in a preform or a temporary cavity in a preform to act as a gatherer or trapper of any solid, liquid or gaseous oxidant. Specifically, in order to minimize the formation of
30 oxidation reaction product due to, for example oxidizing impurities which may be present in the infiltrating atmosphere or may become present in the infiltrating atmosphere and which, if not controlled, may react with molten matrix metal to form a reaction product, it may be
35 desirable to include an oxidant gatherer.

Thus, to obtain spontaneous infiltration, an infiltration enhancer precursor or an infiltration enhancer may be supplied directly to at least one of the preform, and/or matrix metal, and/or infiltrating atmosphere. However, ultimately, at least during the spontaneous infiltration, the infiltration enhancer should be located in at least a portion of the preform.

It is noted that this application discusses primarily aluminum matrix metals which, at some point during the formation of the metal matrix composite body, are contacted with magnesium, which functions as the infiltration enhancer precursor, in the presence of nitrogen, which functions as the infiltrating atmosphere. Thus, the matrix metal/infiltration enhancer precursor/infiltrating atmosphere system of aluminum/magnesium/nitrogen exhibits spontaneous infiltration. However, other matrix metal/infiltration enhancer precursor/infiltrating atmosphere systems may also behave in a manner similar to the system aluminum/magnesium/nitrogen. For example, similar spontaneous infiltration behavior has been observed in the aluminum/strontium/nitrogen system; the aluminum/zinc/oxygen system; and the aluminum/calcium/nitrogen system. Accordingly, even though the aluminum/magnesium/nitrogen system is discussed primarily herein, it should be understood that other matrix metal/infiltration enhancer precursor/infiltrating atmosphere systems may behave in a similar manner.

When the matrix metal comprises an aluminum alloy, the aluminum alloy is contacted with a preform comprising a filler material (e.g., alumina or silicon carbide particles), said filler material having admixed therewith, and/or at some point during the process being exposed to, magnesium. Moreover, in a preferred embodiment, the aluminum alloy and preform are contained in a nitrogen

atmosphere for at least a portion of the process. The preform will be spontaneously infiltrated by the matrix metal and the extent or rate of spontaneous infiltration and formation of metal matrix will vary with a given set of process conditions including, for example, the concentration of magnesium provided to the system (e.g., in the aluminum alloy and/or in the preform and/or in the infiltrating atmosphere), the size and/or composition of the particles in the preform, the concentration of nitrogen in the infiltrating atmosphere, the time permitted for infiltration, and/or the temperature at which infiltration occurs. Spontaneous infiltration typically occurs to an extent sufficient to embed substantially completely the preform.

15

Definitions

"Aluminum", as used herein, means and includes essentially pure metal (e.g., a relatively pure, commercially available unalloyed aluminum) or other grades of metal and metal alloys such as the commercially available metals having impurities and/or alloying constituents such as iron, silicon, copper, magnesium, manganese, chromium, zinc, etc., therein. An aluminum alloy for purposes of this definition is an alloy or intermetallic compound in which aluminum is the major constituent.

"Balance Non-Oxidizing Gas", as used herein, means that any gas present in addition to the primary gas comprising the infiltrating atmosphere, is either an inert gas or a reducing gas which is substantially non-reactive with the matrix metal under the process conditions. Any oxidizing gas which may be present as an impurity in the gas(es) used should be insufficient to oxidize the matrix metal to any substantial extent under the process conditions.

35

"Barrier" or "barrier means", as used herein, means any suitable means which interferes, inhibits, prevents or terminates the migration, movement, or the like, of molten matrix metal beyond a surface boundary of a permeable mass of filler material or preform, where such surface boundary is defined by said barrier means. Suitable barrier means may be any such material, compound, element, composition, or the like, which, under the process conditions, maintains some integrity and is not substantially volatile (i.e., the barrier material does not volatilize to such an extent that it is rendered non-functional as a barrier).

Further, suitable "barrier means" includes materials which are substantially non-wettable by the migrating molten matrix metal under the process conditions employed. A barrier of this type appears to exhibit substantially little or no affinity for the molten matrix metal, and movement beyond the defined surface boundary of the mass of filler material or preform is prevented or inhibited by the barrier means. The barrier reduces any final machining or grinding that may be required and defines at least a portion of the surface of the resulting metal matrix composite product. The barrier may in certain cases be permeable or porous, or rendered permeable by, for example, drilling holes or puncturing the barrier, to permit gas to contact the molten matrix metal.

"Carcass" or "Carcass of Matrix Metal", as used herein, refers to any of the original body of matrix metal remaining which has not been consumed during formation of the metal matrix composite body, and typically, if allowed to cool, remains in at least partial contact with the metal matrix composite body which has been formed. It should be understood that the carcass may also include a second or foreign metal therein.

"Cavity", as used herein, means any unfilled space within a mass or body which either naturally occurs or is

artificially created, and is not limited to any specific configuration of space. Specifically, a cavity can include those spaces which are substantially closed off from communication to an exterior portion of the mass or
5 body, but still can permit communication with an exterior portion of the mass or body. Moreover, a cavity includes a non-naturally occurring (i.e., a temporary cavity) partially closed off space in a body, which can be made into a cavity by inserting in at least a portion of the
10 non-closed off space, a plugging means, which assists in forming a temporary cavity within a body.

"Filler", as used herein, is intended to include either single constituents or mixtures of constituents which are substantially non-reactive with and/or of
15 limited solubility in the matrix metal and may be single or multi-phase. Fillers may be provided in a wide variety of forms, such as powders, flakes, platelets, microspheres, whiskers, bubbles, fibres, particulates, fibre mats, chopped fibres, spheres, pellets, tubules,
20 refractory cloths, etc., and may be either dense or porous. "Filler" may also include ceramic fillers, such as alumina or silicon carbide as fibers, chopped fibers, particulates, whiskers, bubbles, spheres, fiber mats, or the like, and ceramic-coated fillers such as carbon
25 fibers coated with alumina or silicon carbide to protect the carbon from attack, for example, by a molten aluminum matrix metal. Fillers may also include metals.

"Infiltrating Atmosphere", as used herein, means that atmosphere which is present which interacts with the
30 matrix metal and/or preform (or filler material) and/or infiltration enhancer precursor and/or infiltration enhancer and permits or enhances spontaneous infiltration of the matrix metal to occur.

"Infiltration Enhancer", as used herein, means a
35 material which promotes or assists in the spontaneous infiltration of a matrix metal into a filler material or preform. An infiltration enhancer may be formed from,



for example, (1) a reaction of an infiltration enhancer precursor with an infiltrating atmosphere to form a gaseous species and/or (2) a reaction product of the infiltration enhancer precursor and the infiltrating atmosphere and/or (3) a reaction product of the infiltration enhancer precursor and the filler material or preform. Moreover, the infiltration enhancer may be supplied directly to at least one of the preform, and/or matrix metal, and/or infiltrating atmosphere and function in a substantially similar manner to an infiltration enhancer which has formed as a reaction between an infiltration enhancer precursor and another species.

Ultimately, at least during the spontaneous infiltration, the infiltration enhancer should be located in at least a portion of the filler material or preform to achieve spontaneous infiltration and the infiltration enhancer may be at least partially reducible by the matrix metal.

"Infiltration Enhancer Precursor" or "Precursor to the Infiltration Enhancer", as used herein, means a material which when used in combination with (1) the matrix metal, (2) the preform or filler material and/or an infiltrating atmosphere forms an infiltration enhancer which induces or assists the matrix metal to spontaneously infiltrate the filler material or preform. Without wishing to be bound by any particular theory or explanation, it appears as though it may be necessary for the precursor to the infiltration enhancer to be capable of being positioned, located or transportable to a location which permits the infiltration enhancer precursor to interact with the infiltrating atmosphere and/or the preform or filler material and/or the matrix metal. For example, in some matrix metal/infiltration enhancer precursor/infiltrating atmosphere systems, it is desirable for the infiltration enhancer precursor to volatilize at, near, or, in some cases, even somewhat above the temperature at which the matrix metal becomes molten. Such volatilization may lead to: (1) a reaction of the



infiltration enhancer precursor with the infiltrating atmosphere to form a gaseous species which enhances wetting of the filler material or preform by the matrix metal; and/or (2) a reaction of the infiltration enhancer precursor with the infiltrating atmosphere to form a solid, liquid or gaseous infiltration enhancer in at least a portion of the filler material or preform which enhances wetting; and/or (3) a reaction of the infiltration enhancer precursor within the filler material or preform which forms a solid, liquid or gaseous infiltration enhancer in at least a portion of the filler material or preform which enhances wetting.

"Matrix Metal" or "Matrix Metal Alloy", as used herein, means that metal which is utilized to form a metal matrix composite (e.g., before infiltration) and/or that metal which is intermingled with a filler material to form a metal matrix composite body (e.g., after infiltration). When a specified metal is mentioned as the matrix metal, it should be understood that such matrix metal includes that metal as an essentially pure metal, a commercially available metal having impurities and/or alloying constituents therein, an intermetallic compound or an alloy in which that metal is the major or predominant constituent.

"Matrix Metal/Infiltration Enhancer Precursor/Infiltrating Atmosphere System" or "Spontaneous System", as used herein, refers to that combination of materials which exhibits spontaneous infiltration into a preform or filler material. It should be understood that whenever a "/" appears between an exemplary matrix metal, infiltration enhancer precursor and infiltrating atmosphere, the "/" is used to designate a system or combination of materials which, when combined in a particular manner, exhibits spontaneous infiltration into a preform or filler material.

"Metal Matrix Composite" or "MMC", as used herein, means a material comprising a two- or three-dimensionally interconnected alloy or matrix metal which has embedded a preform or filler material. The matrix metal may include various alloying elements to provide specifically desired mechanical and physical properties in the resulting composite.

A Metal "Different" from the Matrix Metal means a metal which does not contain, as a primary constituent, the same metal as the matrix metal (e.g., if the primary constituent of the matrix metal is aluminum, the "different" metal could have a primary constituent of, for example, nickel).

"Non-Infiltrating Atmosphere", as used herein, means that atmosphere which may or may not interact with the matrix metal and/or preform (or filler material) and/or infiltration precursor and/or infiltration enhancer, but which does not permit or enhance, and which may even inhibit, spontaneous infiltration of the matrix metal to occur.

"Nonreactive Vessel for Housing Matrix Metal" means any vessel which can house or contain molten matrix metal under the process conditions and not react with the matrix and/or the infiltrating atmosphere and/or infiltration enhancer precursor and/or filler material or preform in a manner which would be significantly detrimental to the spontaneous infiltration mechanism.

"Oxidant Gatherer", as used herein, means any suitable material (e.g., titanium metal chips) which when used in combination with the matrix metal/infiltration enhancer/infiltrating atmosphere under the process conditions for spontaneous infiltration may be used to gather or trap any solid, liquid or gaseous oxidant present in the reaction system which would inhibit spontaneous infiltration of the matrix metal into the

filler material or preform. Preferably, the oxidant gatherer will not react substantially with any components in the spontaneous system in a manner which substantially deleteriously affects spontaneous infiltration under the process conditions.

"Plugging Means" or "Plug", as used herein, means any material which can be utilized in combination with a preform which assists in creating within the preform a temporary cavity. Preferably, the plugging means will not react with any components in the spontaneous system in a manner which substantially deleteriously affects spontaneous infiltration under the process conditions. The plugging means may or may not be removable from the preform after infiltration of the preform. Moreover, the plugging means may be infiltrated by molten matrix metal to form an integral part of the preform.

"Preform" or "Permeable Preform", as used herein, means a porous mass of filler or filler material which is manufactured with at least one surface boundary which essentially defines a boundary for infiltrating matrix metal, such mass retaining sufficient shape integrity and green strength to provide dimensional fidelity prior to being infiltrated by the matrix metal. The mass should be sufficiently porous to accommodate spontaneous infiltration of the matrix metal thereinto. A preform typically comprises a bonded array or arrangement of filler, either homogeneous or heterogeneous, and may be comprised of any suitable material (e.g., ceramic and/or metal particulates, powders, fibers, whiskers, etc., and any combination thereof). A preform may exist either singularly or as an assemblage.

"Reservoir", as used herein, means a separate body of matrix metal positioned relative to a mass of filler or a preform so that, when the metal is molten, it may flow to replenish, or in some cases to initially provide and

subsequently replenish, that portion, segment or source of matrix metal which is in contact with the filler or preform.

5 "Restriction Means" or "Restricting Means", as used
herein, means any material which can be used in
combination with a preform which assists in restricting
the exit flow of infiltrating atmosphere from a cavity in
a preform and/or which restricts or reduces the
communication of the cavity in the preform with any
10 non-infiltrating atmosphere which may be present.
Preferably, restricting means do not react with any
components in the spontaneous system which may result in a
substantial deleterious effect upon spontaneous
infiltration.

15 "Spontaneous Infiltration", as used herein, means
the infiltration of matrix metal into the permeable mass
of filler or preform occurs without requirement for the
application of pressure or vacuum (whether externally
applied or internally created).

20 "Temporary Cavity", as used herein, means a cavity
created by a plugging means, such cavity being
non-naturally occurring in the preform and which exists
only so long as the plugging means remains in contact with
the preform.

25

Brief Description of the Figures

The following Figures are provided to assist in
understanding the invention, but are not intended to limit
the scope of the invention. Similar reference numerals
30 have been used wherever possible in each of the Figures to
denote like components, wherein:

Figure 1 is a schematic cross-section of an
assemblage of materials utilized to obtain an outside-in
infiltration of a preform;

Figure 2 is a schematic cross-section of an assemblage of materials utilized to obtain an outside-in infiltration of a preform;

Figure 3 is a schematic cross-section of an assemblage of materials utilized to obtain an outside-in infiltration of a preform;

Figure 4 is a schematic cross-section of an assemblage of materials utilized in accordance with Example 1;

Figure 5a is a photograph taken from a side view of the metal matrix composite produced in accordance with Example 1; and

Figure 5b is a photograph taken from a top view of the metal matrix composite produced in accordance with Example 1.

Detailed Description of the Invention and Preferred Embodiments

The present invention relates to forming metal matrix composite bodies by exposing a preform at least partially to molten matrix metal. The preform contains, in at least a portion thereof not initially in contact with molten matrix metal, a cavity. Moreover, the preform contacts, at some point during the process, at least one of an infiltration enhancer and/or an infiltration enhancer precursor and/or an infiltrating atmosphere, which results in molten matrix metal spontaneously infiltrating the preform from an exterior portion thereof toward the cavity.

Specifically, as shown in Figure 1, a matrix metal is made molten and the matrix metal is held within an appropriate non-reactive vessel for housing matrix metal (21) (e.g., a suitable refractory container) to form a body of molten matrix metal (20). The preform (22) containing the cavity (30) can be placed at least

partially into the molten matrix metal (20) such that an infiltrating atmosphere (23) can communicate with the cavity (30) in the preform for at least a portion of the process in order to obtain spontaneous infiltration of
5 molten matrix metal from an exterior surface of the preform toward the cavity therein. The infiltrating atmosphere can flow out of the preform as shown by (24).

Moreover, an infiltration enhancer and/or an infiltration enhancer precursor communicate with the
10 preform, at least at some point during the process, which permits or induces molten matrix metal to spontaneously infiltrate the preform when an exterior surface of the preform is placed into at least partial contact with molten matrix metal. Thus, molten matrix metal
15 infiltrates the preform from an outside surface thereof towards the cavity, thus producing a metal matrix composite body having substantially the geometry of the preform.

In a preferred embodiment, an infiltrating
20 atmosphere is substantially continuously supplied to a cavity or interior portion in a preform. An exterior portion or surface of the preform is exposed (e.g., by at least partially submerging) to molten matrix metal. The substantially simultaneous exposure of the cavity in the
25 preform to an infiltrating atmosphere and exposure of the exterior surface of the preform to molten matrix metal causes the molten matrix metal to spontaneously infiltrate the preform, so long as an infiltration enhancer precursor and/or an infiltration enhancer are also provided to the
30 spontaneous system in at least one of the matrix metal and/or the preform and/or the infiltrating atmosphere.

In a further preferred embodiment, prior to exposing to molten matrix metal a cylindrical or tubular shaped preform which does not contain a natural cavity, a
35 temporary cavity is formed in the preform. Particularly,

as shown in Figure 2, for example, an open end of the preform (22) which is immersed into molten matrix metal (20) can be plugged with an appropriate plugging means (25). Such plugging means (25) serves to create a
5 temporary cavity (30) in the preform (22). Accordingly, the temporary cavity (30) can accept and maintain an infiltrating atmosphere (23) for a requisite amount of time. In a preferred embodiment, the plugging means (25) may comprise a material which is substantially
10 non-reactive with each of, or at least one of, the matrix metal (20) and/or the preform (22) and/or the infiltrating atmosphere (23) and/or the infiltration enhancer and/or the infiltration enhancer precursor. Once such a preform (22) includes a plugging means (25) therein to create a
15 temporary cavity (30), molten matrix metal (20) may spontaneously infiltrate the preform (22) from an exterior surface thereof toward the temporary cavity (30).

In another preferred embodiment, the plugging means (25) can be chosen so that it not only serves its purpose
20 of creating a temporary cavity (30), but it also may be spontaneously infiltrated by molten matrix metal (20). In this case, the plugging means (25) becomes an integral part of the metal matrix composite body.

In another preferred embodiment, a naturally formed
25 cavity in a preform, or a temporary cavity which is formed by the use of a plugging means, further includes, in a portion thereof, a restricting means which restricts or reduces the communication of the cavity in the preform with any non-infiltrating atmosphere which may be present.
30 Particularly, as shown in Figure 3, in order to create a more confined or self-contained atmosphere within a naturally occurring cavity (30) or a temporary cavity (30), an open end of the preform (22) is at least partially restricted or closed by a restricting means (26)
35 so that infiltrating atmosphere (23) which is to flow into

the cavity (30) is restricted from escaping and/or any non-infiltrating atmosphere (e.g., an oxidant) may be restricted from communicating with the cavity. The use of said restricting means (26) in the preform (22) may assist molten matrix metal to spontaneously infiltrate the preform (22) from an exterior portion of the preform toward the cavity in the preform.

In a still further preferred embodiment, an oxidant gatherer may be placed into a natural cavity in a preform or a temporary cavity in a preform to act as a gatherer or trapper of any solid, liquid or gaseous oxidant. Specifically, in order to minimize the formation of oxidation reaction product due to, for example oxidizing impurities which may be present in the infiltrating atmosphere or which may become present in the infiltrating atmosphere and which, if not controlled, may react with molten matrix metal to form a reaction product, it may be desirable to include an oxidant gatherer in the cavity of a preform. Accordingly, as shown in Figure 1, an oxidant gatherer (27) may be placed within the cavity (30). Preferably, the oxidant gatherers will not react substantially with any components in the spontaneous system in a manner which substantially deleteriously affects spontaneous infiltration under the process conditions.

Moreover, to obtain spontaneous infiltration, an infiltration enhancer precursor or an infiltration enhancer may be supplied directly to at least one of the preform, and/or matrix metal, and/or infiltrating atmosphere. However, ultimately, at least during the spontaneous infiltration, the infiltration enhancer should be located in at least a portion of the preform.

It may also be possible to expose a permeable mass of filler material to molten matrix metal to obtain spontaneous infiltration of the filler material.

Specifically, a permeable mass of filler material which may rigidize (e.g., sinter) upon heating to form a solid mass may be placed into a mold which is consumed (e.g., volatilizes or interdiffuses with matrix metal) during the
5 reaction to create a mold containing filler material and having a cavity, either naturally occurring or artificially created, therein which is exposed to an infiltrating atmosphere.

The mold containing alloy is heated, either upon
10 placing it into a heated furnace containing the molten matrix metal or in a separate step, to substantially rigidize the permeable mass of filler material. The mold containing the substantially rigidized filler material is exposed (e.g., by at least partially submerging) to molten
15 matrix alloy. The substantially simultaneous exposure of the cavity in the substantially rigidized mass of filler material to an infiltrating atmosphere and exposure of the exterior of the substantially rigidized preform causes the molten matrix metal to spontaneously infiltrate the filler
20 material, so long as infiltration enhancer precursor and/or infiltrating atmosphere and/or the infiltration enhancer and/or the infiltration enhancer precursor. Once such a filler material includes a plugging means therein to create a temporary cavity, molten matrix metal may
25 spontaneously infiltrate the preform from an exterior surface thereof toward the temporary cavity.

In order to effect spontaneous infiltration of the matrix metal into the filler material or preform, an infiltration enhancer should be provided to the
30 spontaneous system. An infiltration enhancer could be formed from an infiltration enhancer precursor which could be provided (1) in the matrix metal; and/or (2) in the filler material or preform; and/or (3) from the infiltrating atmosphere and/or (4) from an external source
35 into the spontaneous system. Moreover, rather than

supplying an infiltration enhancer precursor, an infiltration enhancer may be supplied directly to at least one of the filler material or preform, and/or matrix metal, and/or infiltrating atmosphere. Ultimately, at least during the spontaneous infiltration, the infiltration enhancer should be located in at least a portion of the filler material or preform.

In a preferred embodiment, it is possible that the infiltration enhancer precursor can be at least partially reacted with the infiltrating atmosphere such that infiltration enhancer can be formed in at least a portion of the filler material or preform prior to or substantially simultaneously with contacting the preform with molten matrix metal (e.g., if magnesium was the infiltration enhancer precursor and nitrogen was the infiltrating atmosphere, the infiltration enhancer could be magnesium nitride which would be located in at least a portion of the filler material or preform).

An example of a matrix metal/infiltration enhancer precursor/infiltrating atmosphere system is the aluminum/magnesium/nitrogen system. Specifically, an aluminum matrix metal can be contained within a suitable refractory vessel which, under the process conditions, does not react with the aluminum matrix metal when the aluminum is made molten. A filler material containing or being exposed to magnesium, and being exposed to, at least at some point during the processing, a nitrogen atmosphere, can then be contacted with the molten aluminum matrix metal. The matrix metal will then spontaneously infiltrate the filler material or preform.

Under the conditions employed in the method of the present invention, in the case of an aluminum/magnesium/nitrogen spontaneous infiltration system, the filler material or preform should be sufficiently permeable to permit the nitrogen-containing gas to penetrate or

permeate the filler material or preform at some point during the process and/or contact the molten matrix metal. Moreover, the permeable filler material or preform can accommodate infiltration of the molten matrix metal, 5 thereby causing the nitrogen-permeated filler material or preform to be infiltrated spontaneously with molten matrix metal to form a metal matrix composite body and/or cause the nitrogen to react with an infiltration enhancer precursor to form infiltration enhancer in the filler 10 material or preform and thereby resulting in spontaneous infiltration. The extent or rate of spontaneous infiltration and formation of the metal matrix composite will vary with a given set of process conditions, including magnesium content of the aluminum alloy, 15 magnesium content of the filler material or preform, amount of magnesium nitride in the filler material or preform, the presence of additional alloying elements (e.g., silicon, iron, copper, manganese, chromium, zinc, and the like), average size of the filler material (e.g., 20 particle diameter), surface condition and type of filler material, nitrogen concentration of the infiltrating atmosphere, time permitted for infiltration and temperature at which infiltration occurs. For example, for infiltration of the molten aluminum matrix metal to 25 occur spontaneously, the aluminum can be alloyed with at least about 1 percent by weight, and preferably at least about 3 percent by weight, magnesium (which functions as the infiltration enhancer precursor), based on alloy weight. Auxiliary alloying elements, as discussed above, 30 may also be included in the matrix metal to tailor specific properties thereof. (Additionally, the auxiliary alloying elements may affect the minimum amount of magnesium required in the matrix aluminum metal to result in spontaneous infiltration of the filler material or 35 preform). Loss of magnesium from the spontaneous system

due to, for example, volatilization should not occur to such an extent that no magnesium is present to form infiltration enhancer. Thus, it is desirable to utilize a sufficient amount of initial alloying elements to assure
5 that spontaneous infiltration will not be adversely affected by volatilization. Still further, the presence of magnesium in both of the filler material or preform and matrix metal or the filler material or preform alone may result in a lesser required amount of magnesium to achieve
10 spontaneous infiltration (discussed in greater detail later herein). The volume percent of nitrogen in the nitrogen atmosphere also affects formation rates of the metal matrix composite body. Specifically, if less than about 10 volume percent of nitrogen is present in the
15 atmosphere, very slow or little spontaneous infiltration will occur. It has been discovered that it is preferable for at least about 50 volume percent of nitrogen to be present in the atmosphere, thereby resulting in, for example, shorter infiltration times due to a much more
20 rapid rate of infiltration. The infiltrating atmosphere (e.g., a nitrogen-containing gas) can be supplied directly to the filler material or preform and/or matrix metal, or it may be produced or result from a decomposition of a material.

25 The minimum magnesium content required for molten matrix metal to infiltrate a filler material or preform depends on one or more variables such as the processing temperature, time, the presence of auxiliary alloying elements such as silicon or zinc, the nature of the filler
30 material, the location of the magnesium in one or more components of the spontaneous system, the nitrogen content of the atmosphere, and the rate at which the nitrogen atmosphere flows. Lower temperatures or shorter heating times can be used to obtain complete infiltration as the
35 magnesium content of the alloy and/or preform is increased.

Also, for a given magnesium content, the addition of certain auxiliary alloying elements such as zinc permits the use of lower temperatures. For example, a magnesium content of the matrix metal at the lower end of the operable range, e.g., from about 1 to 3 weight percent, may be used in conjunction with at least one of the following: an above-minimum processing temperature, a high nitrogen concentration, or one or more auxiliary alloying elements. When no magnesium is added to the filler material or preform, alloys containing from about 3 to 5 weight percent magnesium are preferred on the basis of their general utility over a wide variety of process conditions, with at least about 5 percent being preferred when lower temperatures and shorter times are employed. Magnesium contents in excess of about 10 percent by weight of the aluminum alloy may be employed to moderate the temperature conditions required for infiltration. The magnesium content may be reduced when used in conjunction with an auxiliary alloying element, but these elements serve an auxiliary function only and are used together with at least the above-specified minimum amount of magnesium. For example, there was substantially no infiltration of nominally pure aluminum alloyed only with 10 percent silicon at 1000°C into a bedding of 500 mesh, 39 Crystolon (99 percent pure silicon carbide from Norton Co.). However, in the presence of magnesium, silicon has been found to promote the infiltration process. As a further example, the amount of magnesium varies if it is supplied exclusively to the preform or filler material. It has been discovered that spontaneous infiltration will occur with a lesser weight percent of magnesium supplied to the spontaneous system when at least some of the total amount of magnesium supplied is placed in the preform or filler material. It may be desirable for a lesser amount of magnesium to be provided in order to prevent the

formation of undesirable intermetallics in the metal matrix composite body. In the case of a silicon carbide preform, it has been discovered that when the preform is contacted with an aluminum matrix metal, the preform
5 containing at least about 1 percent by weight magnesium and being in the presence of a substantially pure nitrogen atmosphere, the matrix metal spontaneously infiltrates the preform. In the case of an alumina preform, the amount of magnesium required to achieve acceptable spontaneous
10 infiltration is slightly higher. Specifically, it has been found that when an alumina preform, when contacted with a similar aluminum matrix metal, at about the same temperature as the aluminum that infiltrated into the silicon carbide preform, and in the presence of the same
15 nitrogen atmosphere, at least about 3 percent by weight magnesium may be required to achieve similar spontaneous infiltration to that achieved in the silicon carbide preform discussed immediately above.

It is also noted that it is possible to supply to
20 the spontaneous system infiltration enhancer precursor and/or infiltration enhancer on a surface of the alloy and/or on a surface of the preform or filler material and/or within the preform or filler material prior to infiltrating the matrix metal into the filler material or
25 preform (i.e., it may not be necessary for the supplied infiltration enhancer or infiltration enhancer precursor to be alloyed with the matrix metal, but rather, simply supplied to the spontaneous system). If the magnesium was applied to a surface of the matrix metal it may be
30 preferred that said surface should be the surface which is closest to, or preferably in contact with, the permeable mass of filler material or vice versa; or such magnesium could be mixed into at least a portion of the preform or filler material. Still further, it is possible that some
35 combination of surface application, alloying and placement

of magnesium into at least a portion of the preform could be used. Such combination of applying infiltration enhancer(s) and/or infiltration enhancer precursor(s) could result in a decrease in the total weight percent of magnesium needed to promote infiltration of the matrix aluminum metal into the preform, as well as achieving lower temperatures at which infiltration can occur. Moreover, the amount of undesirable intermetallics formed due to the presence of magnesium could also be minimized.

10 The use of one or more auxiliary alloying elements and the concentration of nitrogen in the surrounding gas also affects the extent of nitriding of the matrix metal at a given temperature. For example, auxiliary alloying elements such as zinc or iron included in the alloy, or placed on a surface of the alloy, may be used to reduce the infiltration temperature and thereby decrease the amount of nitride formation, whereas increasing the concentration of nitrogen in the gas may be used to promote nitride formation.

20 The concentration of magnesium in the alloy, and/or placed onto a surface of the alloy, and/or combined in the filler or preform material, also tends to affect the extent of infiltration at a given temperature. Consequently, in some cases where little or no magnesium is contacted directly with the preform or filler material, it may be preferred that at least about three weight percent magnesium be included in the alloy. Alloy contents of less than this amount, such as one weight percent magnesium, may require higher process temperatures or an auxiliary alloying element for infiltration. The temperature required to effect the spontaneous infiltration process of this invention may be lower: (1) when the magnesium content of the alloy alone is increased, e.g. to at least about 5 weight percent; and/or 35 (2) when alloying constituents are mixed with the

permeable mass of filler material or preform; and/or (3) when another element such as zinc or iron is present in the aluminum alloy. The temperature also may vary with different filler materials. In general, spontaneous and
5 progressive infiltration will occur at a process temperature of at least about 675°C, and preferably a process temperature of at least about 750°C-800°C. Temperatures generally in excess of 1200°C do not appear to benefit the process, and a particularly useful
10 temperature range has been found to be from about 675°C to about 1200°C. However, as a general rule, the spontaneous infiltration temperature is a temperature which is above the melting point of the matrix metal but below the volatilization temperature of the matrix metal. Moreover,
15 the spontaneous infiltration temperature should be below the melting point of the filler material. Still further, as temperature is increased, the tendency to form a reaction product between the matrix metal and infiltrating atmosphere increases (e.g., in the case of aluminum matrix
20 metal and a nitrogen infiltrating atmosphere, aluminum nitride may be formed). Such reaction product may be desirable or undesirable based upon the intended application of the metal matrix composite body. Additionally, electric resistance heating is typically
25 used to achieve the infiltrating temperatures. However, any heating means which can cause the matrix metal to become molten and does not adversely affect spontaneous infiltration, is acceptable for use with the invention.

In the present method, for example, a permeable
30 filler material or preform is placed into contact with molten aluminum in the presence of, at least sometime during the process, a nitrogen-containing gas. The nitrogen-containing gas may be supplied by maintaining a continuous flow of gas into contact with at least one of
35 the filler material or the preform. Although the flow

rate of the nitrogen-containing gas is not critical, it is preferred that the flow rate be sufficient to prevent or inhibit the incursion of air which can have an oxidizing effect on the molten metal.

5 The method of forming a metal matrix composite is applicable to a wide variety of filler materials, and the choice of filler materials will depend on such factors as the matrix alloy, the process conditions, the reactivity of the molten matrix alloy with the filler material, and
10 the properties sought for the final composite product. For example, when aluminum is the matrix metal, suitable filler materials include (a) oxides, e.g. alumina; (b) carbides, e.g. silicon carbide; (c) borides, e.g. aluminum dodecaboride, and (d) nitrides, e.g. aluminum nitride. If
15 there is a tendency for the filler material to react with the molten aluminum matrix metal, this might be accommodated by minimizing the infiltration time and temperature or by providing a non-reactive coating on the filler. The filler material may comprise a substrate,
20 such as carbon or other non-ceramic material, bearing a ceramic coating to protect the substrate from attack or degradation. Suitable ceramic coatings include oxides, carbides, borides and nitrides. Ceramics which are preferred for use in the present method include alumina and silicon carbide in the form of particles, platelets,
25 whiskers and fibers. The fibers can be discontinuous (in chopped form) or in the form of continuous filament, such as multifilament tows. Further, the filler material or preform may be homogeneous or heterogeneous.

30 It also has been discovered that certain filler materials exhibit enhanced infiltration relative to filler materials by having a similar chemical composition. For example, crushed alumina bodies made by the method disclosed in U.S. Patent No. 4,713,360, entitled "Novel
35 Ceramic Materials and Methods of Making Same", which

issued on December 15, 1987, in the names of Marc S. Newkirk et al., exhibit desirable infiltration properties relative to commercially available alumina products.

Moreover, crushed alumina bodies made by the method disclosed ⁱⁿ ~~in Copending and Commonly Owned Application~~ ^{US Patent 4851315} ~~Application~~ Serial No. 819,397 entitled "~~Composite Ceramic Articles and Methods of Making Same~~", in the names of Marc S.

~~Newkirk et al.~~, also exhibit desirable infiltration properties relative to commercially available alumina products. The subject matter of each of the issued Patent and Copending Patent Application is herein expressly incorporated by reference. Thus, it has been discovered that complete infiltration of a permeable mass of ceramic material can occur at lower infiltration temperatures and/or lower infiltration times by utilizing a crushed or comminuted body produced by the method of the aforementioned U.S. Patent and Patent Application.

The size and shape of the filler material can be any that may be required to achieve the properties desired in the composite. Thus, the material may be in the form of particles, whiskers, platelets or fibers since infiltration is not restricted by the shape of the filler material. Other shapes such as spheres, tubules, pellets, refractory fiber cloth, and the like may be employed. In addition, the size of the material does not limit infiltration, although a higher temperature or longer time period may be needed for complete infiltration of a mass of smaller particles than for larger particles. Further, the mass of filler material (shaped into a preform) to be infiltrated should be permeable (i.e., permeable to molten matrix metal and to the infiltrating atmosphere)

The method of forming metal matrix composites according to the present invention, not being dependent on the use of pressure to force or squeeze molten matrix metal into a preform or a mass of filler material, permits



the production of substantially uniform metal matrix composites having a high volume fraction of filler material and low porosity. Higher volume fractions of filler material may be achieved by using a lower porosity initial mass of filler material. Higher volume fractions also may be achieved if the mass of filler is compacted or otherwise densified provided that the mass is not converted into either a compact with close cell porosity or into a fully dense structure that would prevent infiltration by the molten alloy.

It has been observed that for aluminum infiltration and matrix formation around a ceramic filler, wetting of the ceramic filler by the aluminum matrix metal may be an important part of the infiltration mechanism. Moreover, at low processing temperatures, a negligible or minimal amount of metal nitriding occurs resulting in a minimal discontinuous phase of aluminum nitride dispersed in the metal matrix. However, as the upper end of the temperature range is approached, nitridation of the metal is more likely to occur. Thus, the amount of the nitride phase in the metal matrix can be controlled by varying the processing temperature at which infiltration occurs. The specific process temperature at which nitride formation becomes more pronounced also varies with such factors as the matrix aluminum alloy used and its quantity relative to the volume of filler or preform, the ceramic material to be infiltrated, and the nitrogen concentration of the infiltrating atmosphere. For example, the extent of aluminum nitride formation at a given process temperature is believed to increase as the ability of the alloy to wet the ceramic filler decreases and as the nitrogen concentration of the atmosphere increases.

It is therefore possible to tailor the constituency of the metal matrix during formation of the composite to impart certain characteristics to the resulting product.

For a given system, the process conditions can be selected to control the nitride formation. A composite product containing an aluminum nitride phase will exhibit certain properties which can be favorable to, or improve the performance of, the product. Further, the temperature range for spontaneous infiltration with an aluminum alloy may vary with the ceramic material used. In the case of alumina as the filler material, the temperature for infiltration should preferably not exceed about 1000°C if it is desired that the ductility of the matrix not be reduced by the significant formation of nitride. However, temperatures exceeding 1000°C may be employed if it is desired to produce a composite with a less ductile and stiffer matrix. To infiltrate silicon carbide, higher temperatures of about 1200°C may be employed since the aluminum alloy nitrifies to a lesser extent, relative to the use of alumina as filler, when silicon carbide is employed as a filler material.

Moreover, it is possible to use a reservoir of matrix metal to assure complete infiltration of the filler material and/or to supply a second metal which has a different composition from the first source of matrix metal. Specifically, in some cases it may be desirable to utilize a matrix metal in the reservoir which differs in composition from the first source of matrix metal. For example, if an aluminum alloy is used as the first source of matrix metal, then virtually any other metal or metal alloy which was molten at the processing temperature could be used as the reservoir metal. Molten metals frequently are very miscible with each other which would result in the reservoir metal mixing with the first source of matrix metal so long as an adequate amount of time is given for the mixing to occur. Thus, by using a reservoir metal which is different in composition than the first source of matrix metal, it is possible to tailor the properties of

For a given system, the process conditions can be selected to control the nitride formation. A composite product containing an aluminum nitride phase will exhibit certain properties which can be favorable to, or improve the performance of, the product. Further, the temperature range for spontaneous infiltration with an aluminum alloy may vary with the ceramic material used. In the case of alumina as the filler material, the temperature for infiltration should preferably not exceed about 1000°C if it is desired that the ductility of the matrix not be reduced by the significant formation of nitride. However, temperatures exceeding 1000°C may be employed if it is desired to produce a composite with a less ductile and stiffer matrix. To infiltrate silicon carbide, higher temperatures of about 1200°C may be employed since the aluminum alloy nitrides to a lesser extent, relative to the use of alumina as filler, when silicon carbide is employed as a filler material.

Moreover, it is possible to use a reservoir of matrix metal to assure complete infiltration of the filler material and/or to supply a second metal which has a different composition from the first source of matrix metal. Specifically, in some cases it may be desirable to utilize a matrix metal in the reservoir which differs in composition from the first source of matrix metal. For example, if an aluminum alloy is used as the first source of matrix metal, then virtually any other metal or metal alloy which was molten at the processing temperature could be used as the reservoir metal. Molten metals frequently are very miscible with each other which would result in the reservoir metal mixing with the first source of matrix metal so long as an adequate amount of time is given for the mixing to occur. Thus, by using a reservoir metal which is different in composition than the first source of matrix metal, it is possible to tailor the properties of

the metal matrix to meet various operating requirements and thus tailor the properties of the metal matrix composite.

A barrier means may also be utilized in combination
5 with the present invention. Specifically, the barrier means for use with this invention may be any suitable means which interferes, inhibits, prevents or terminates the migration, movement, or the like, of molten matrix alloy (e.g., an aluminum alloy) beyond the defined surface
10 boundary of the filler material. Suitable barrier means may be ^{at least one material, such as a} ~~any material,~~ compound, element, composition, or the like, which, under the process conditions of this invention, maintains some integrity, is not volatile and preferably is permeable to the gas used with the process
15 as well as being capable of locally inhibiting, stopping, interfering with, preventing, or the like, continued infiltration or any other kind of movement beyond the defined surface boundary of the material or preform filler.

20 Suitable barrier means includes materials which are substantially non-wettable by the migrating molten matrix alloy under the process conditions employed. A barrier of this type appears to exhibit little or no affinity for the molten matrix alloy, and movement beyond the defined
25 surface boundary of the filler material or preform is prevented or inhibited by the barrier means. The barrier reduces any final machining or grinding that may be required of the metal matrix composite product. As stated above, the barrier preferably should be permeable or
30 porous, or rendered permeable by puncturing, to permit the gas to contact the molten matrix alloy.

Suitable barriers particularly useful for aluminum matrix alloys are those containing carbon, especially the crystalline allotropic form of carbon known as graphite.
35 Graphite is essentially non-wettable by the molten



aluminum alloy under the described process conditions. A particular preferred graphite is a graphite tape product that is sold under the trademark Grafoil®, registered to Union Carbide. This graphite tape exhibits sealing characteristics that prevent the migration of molten aluminum alloy beyond the defined surface boundary of the filler material. This graphite tape is also resistant to heat and is chemically inert. Grafoil® graphite material is flexible, compatible, conformable and resilient. It can be made into a variety of shapes to fit any barrier application. However, graphite barrier means may be employed as a slurry or paste or even as a paint film around and on the boundary of the filler material or preform. Grafoil® is particularly preferred because it is in the form of a flexible graphite sheet. In use, this paper-like graphite is simply formed around the filler material or preform.

Other preferred barrier(s) for aluminum metal matrix alloys in nitrogen are the transition metal borides (e.g., titanium diboride (TiB_2)) which are generally non-wettable by the molten aluminum metal alloy under certain of the process conditions employed using this material. With a barrier of this type, the process temperature should not exceed about $875^{\circ}C$, for otherwise the barrier material becomes less efficacious and, in fact, with increased temperature infiltration into the barrier will occur. The transition metal borides are typically in a particulate form (1-30 microns). The barrier materials may be applied as a slurry or paste to the boundaries of the permeable mass of ceramic filler material which preferably is preshaped as a preform.

Other useful barriers for aluminum metal matrix alloys in nitrogen include low-volatile organic compounds applied as a film or layer onto the external surface of the filler material or preform. Upon firing in nitrogen,

especially at the process conditions of this invention, the organic compound decomposes leaving a carbon soot film. The organic compound may be applied by conventional means such as painting, spraying, dipping, etc.

5 Moreover, finely ground particulate materials can function as a barrier so long as infiltration of the particulate material would occur at a rate which is slower than the rate of infiltration of the filler material.

 Thus, the barrier means may be applied by any
10 suitable means, such as by covering the defined surface boundary with a layer of the barrier means. Such a layer of barrier means may be applied by painting, dipping, silk screening, evaporating, or otherwise applying the barrier means in liquid, slurry, or paste form, or by sputtering a
15 vaporizable barrier means, or by simply depositing a layer of a solid particulate barrier means, or by applying a solid thin sheet or film of barrier means onto the defined surface boundary. With the barrier means in place, spontaneous infiltration substantially terminates when the
20 infiltrating matrix metal reaches the defined surface boundary and contacts the barrier means.

 The method of this invention provides for a cost-effective production of metal matrix composite bodies by the aforementioned process. Particularly, the use of a
25 localized source of infiltrating atmosphere within the cavity of the filler material or preform reduces the need for more costly processing systems by allowing for processing of composites in an open atmosphere. Similarly, by this method, the formation of metal matrix
30 composite bodies may be carried out by a continuous processing system. Moreover, the produced metal matrix composites have good net or near net shape capabilities.

 Various demonstrations of the present invention are included in the Examples immediately following. However,
35 these Examples should be considered as being illustrative

and should not be construed as limiting the scope of the invention as defined in the appended claims.

Example 1

5 Figure 4 shows an assembly, in cross-section, which can be used to form a metal matrix composite body by an outside-in infiltration precursor. Particularly, a cylindrical preform (3) having a closed end (8) and a cavity (9) was formed by slip casting a slurry of 1000
10 grit silicon carbide (supplied by Exolon-ESK Co. of Tonawanda, New York and sold under the name Carbolon F1000) around an alumina rod having a diameter of approximately 1 1/2 inches by 6 inches long. The slurry was subsequently dried and prefired in an air furnace at
15 1100°C for about five hours to form a preform (3) having a wall thickness of about 5 millimeters. Titanium chips (5) (supplied by Chem Alloy Co., Inc. and sold under the designation QM4-30) were placed within the cavity (9) of the preform (3). The preform (3) was placed into contact
20 with a slightly modified 380.1 aluminum alloy (2) (obtained from Belmont Metals) having a composition of about 7.5-9.5% Si, 3.0-4.0% Cu, <2.9% Zn, <6.0% Fe, <0.5% Mn, <0.5% Ni, <0.35% Sn, and about 0.17-0.18% Mg, to which an additional 5 weight percent magnesium was added. The
25 aluminum alloy was contained within a bed of wollastonite powder (7) (supplied by NYCO, Inc.), all of which was contained in a refractory vessel (1). Wollastonite powder (7) was used because molten aluminum does not readily wet this material and it functions as a container for the
30 molten aluminum. The refractory vessel (1) and its contents were heated in an air furnace to a temperature of about 800°C to render the aluminum alloy molten. A thin coating or layer of wollastonite powder (6) was placed onto surface of the molten alloy (2) which was not in
35 contact with the partially submerged preform (3) to

prevent oxidation of molten alloy (2). An alumina flow tube (4) comminuted an infiltrating atmosphere of about 99.9 percent pure nitrogen gas with the cavity (9) in the preform (3). Thus, a localized nitrogen gas atmosphere
5 was created within the cavity (9). The tube (4) also functioned to retain the preform (3) submerged approximately four inches into the molten alloy (2). The furnace was maintained at about 800°C for about 25 hours. The preform (3) was then removed from the alloy melt (2),
10 but remained within the furnace for about 10 hours until the entire assembly cooled to about room temperature.

The infiltrated preform (2) was removed from the system and inspected. As shown in Figure 5a, which is a side view of the formed metal matrix composite (8), the
15 preform was infiltrated only to a length of about 4 inches, which corresponded to the amount which the preform (2) was immersed in the molten matrix alloy (2). Figure 5b, which is a top view of the metal matrix composite (8), shows the cavity which existed within the preform (2).
20 Accordingly, it is clear from Figures 2a and 2b that the outside-in spontaneous infiltration of molten matrix metal into a preform provides good net or near net shape capabilities.

THE CLAIMS DEFINING THE INVENTION ARE AS FOLLOWS:-

1. A method for making a metal matrix composite, comprising:
 - 5 providing a substantially non-reactive filler, said filler including a cavity portion therein;
communicating a localized infiltrating atmosphere with at least a portion of said cavity in said filler;
 - 10 providing at least one of an infiltration enhancer precursor and an infiltration enhancer; and
spontaneously infiltrating at least a portion of the filler with molten matrix metal.
2. The method of claim 1, comprising the step of supplying said at least one of an infiltration enhancer precursor and an infiltration enhancer to at least one of the matrix metal, the filler and the infiltrating atmosphere.
3. The method of claim 1, comprising the step of supplying said at least one of an infiltration enhancer precursor and an infiltration enhancer to at least one of the matrix metal and the filler.
4. The method of claim 2, wherein said at least one of an infiltration enhancer precursor and an infiltration enhancer is supplied from an external source.
5. The method of claim 1, comprising the step of contacting at least a portion of the filler with said at least one of an infiltration enhancer precursor and an infiltration enhancer during at least a portion of the period of infiltration.
6. The method of claim 2, wherein the infiltration enhancer is formed by reacting an infiltration enhancer precursor and at least one species comprising a member selected from the group consisting of the infiltrating atmosphere, the filler and the matrix metal.



7. The method of claim 6, wherein during infiltration, the infiltration enhancer precursor volatilizes.

8. The method of claim 7, wherein the volatilized infiltration enhancer precursor reacts to form ^{an infiltration enhancer} ~~a reaction product~~ in at least a portion of the filler.

9. The method of claim 8, wherein said ^{infiltration enhancer} ~~reaction product~~ is at least partially reducible by said molten matrix metal.

10. The method of claim 9, wherein said ^{infiltration enhancer} ~~reaction product~~ coats at least a portion of said filler.

11. The method of claim 1, wherein the filler comprises a preform.

12. The method of claim 1, further comprising the step of defining a surface boundary of the filler with a barrier, wherein the matrix metal spontaneously infiltrates up to the barrier.

13. The method of claim 12, wherein the barrier comprises a material selected from the group consisting of carbon, graphite and titanium diboride.

14. The method of claim 12, wherein said barrier is substantially non-wettable by said matrix metal.

15. The method of claim 12, wherein said barrier comprises at least one material which permits communication between an infiltrating atmosphere and at least one of the matrix metal, filler, infiltration enhancer and infiltration enhancer precursor.

16. The method of claim 1, wherein the filler comprises at least one material selected from the group consisting of powders, flakes, platelets, microspheres, whiskers, bubbles, fibers, particulates, fiber mats, chopped fibers, spheres, pellets, tubules and refractory cloths.



17. The method of claim 1, wherein the filler is of limited solubility in the molten matrix metal.

18. The method of claim 1, wherein the filler comprises at least one ceramic material.

19. The method of claim 1, wherein the matrix metal comprises aluminum, the infiltration enhancer precursor comprises at least one material selected from the group consisting of magnesium, strontium and calcium, and the infiltrating atmosphere comprises nitrogen.

20. The method of claim 1, wherein the matrix metal comprises aluminum, the infiltration enhancer precursor comprises zinc, and the infiltrating atmosphere comprises oxygen.

21. The method of claim 1, wherein said at least one of an infiltration enhancer ^{precursor and an} ~~and said infiltration enhancer precursor~~ is provided at a boundary between said filler and said matrix metal.

22. The method of claim 1, wherein an infiltration enhancer precursor is alloyed in said matrix metal.

23. The method of claim 1, wherein said matrix metal comprises aluminum and at least one alloying element selected from the group consisting of silicon, iron, copper, manganese, chromium, zinc, calcium, magnesium and strontium.

24. The method of claim 3, wherein said at least one of an infiltration enhancer precursor and ^{an} infiltration enhancer is provided in both of said matrix metal and said filler.

25. The method of claim 2, wherein said at least one of an infiltration enhancer precursor and ^{an} infiltration enhancer is provided in more than one of said matrix metal, said filler and said infiltrating atmosphere.



26. The method of claim 1, wherein the temperature during spontaneous infiltration is greater than the melting point of the matrix metal, but lower than the volatilization temperature of the matrix metal and the melting point of the filler.

27. The method of claim 1, wherein the infiltrating atmosphere comprises an atmosphere selected from the group consisting of oxygen and nitrogen.

28. The method of claim 2, wherein the infiltration enhancer precursor comprises a material selected from the group consisting of magnesium, strontium and calcium.

29. The method of claim 1, wherein the matrix metal comprises aluminum and the filler comprises at least one material selected from the group consisting of oxides, carbides, borides and nitrides.

30. The method of claim 1 or 2, wherein said filler comprises a preform which defines a cavity and said infiltrating atmosphere is communicated directly with said cavity.

31. The method of claim 30, wherein said cavity is at least partially defined by a plug.

32. The method of claim 31, wherein said plug is integral with said preform.

33. The method claim 31, wherein said plug is removable.

34. The method of claim 1, wherein said spontaneous infiltration is performed in an open atmosphere furnace.

35. The method of claim 30, wherein said infiltrating atmosphere communicates with said cavity via at least one conduit.

36. The method of claims 30 or 35, wherein said cavity is at least partially restricted via restriction means adjacent a portion thereof.



37. The method of claims 1, 30 or 34, further comprising the step of providing an oxidant gatherer.

38. The method of claims 1 or 30, wherein said spontaneous infiltration is performed by at least partially surrounding said preform with said molten matrix metal.

37
38

39. A method for making a metal matrix composite substantially as hereinbefore described with reference to the drawings and/or Examples.

40. A metal matrix composite when made by the method claimed in any one of the preceeding claims.

~~41. The steps, features, compositions and compounds disclosed herein or referred to or indicated in the specification and/or claims of this application, individually or collectively, and any and all combinations of any two or more of said steps or features.~~

DATED this TWENTY FIRST day of SEPTEMBER 1989

Lanxide Corporation

by DAVIES & COLLISON

Patent Attorneys for the applicant(s)



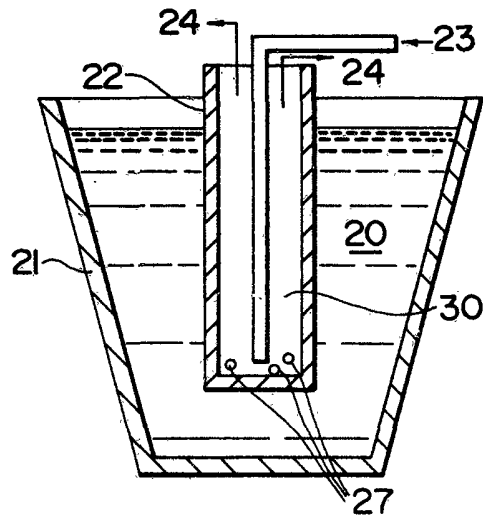

Fig. 1

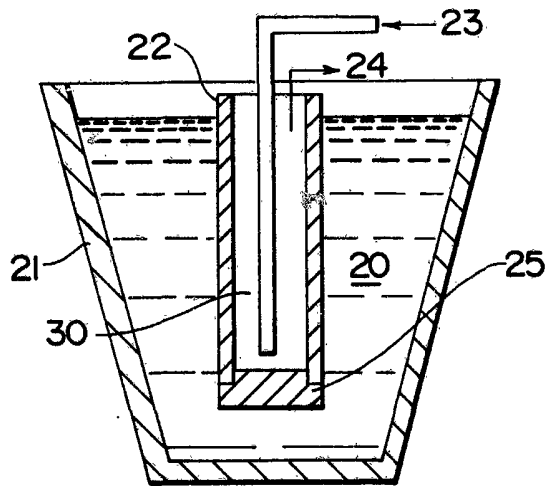

Fig. 2

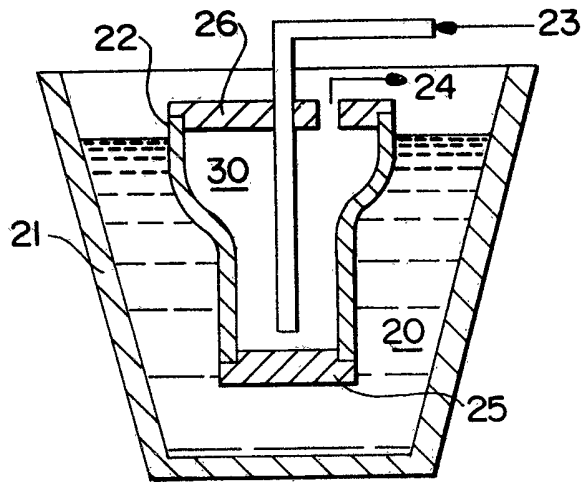

Fig. 3

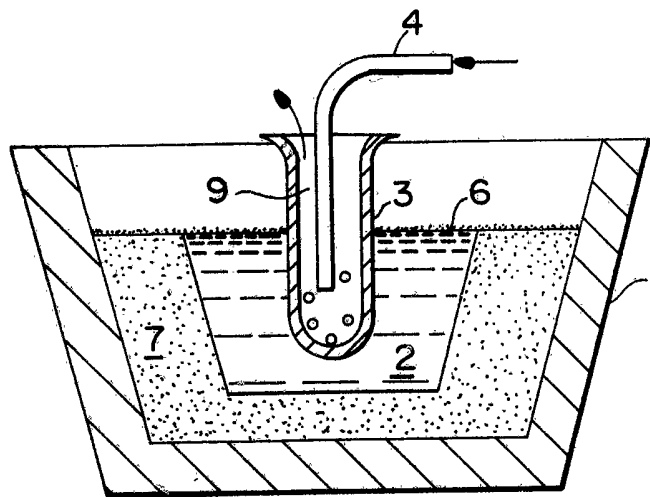

Fig. 4



Fig. 5a



Fig. 5b

