

W. M. DYAS.
HOT AIR REGISTER.

No. 522,200.

Patented July 3, 1894.

FIG. 1.

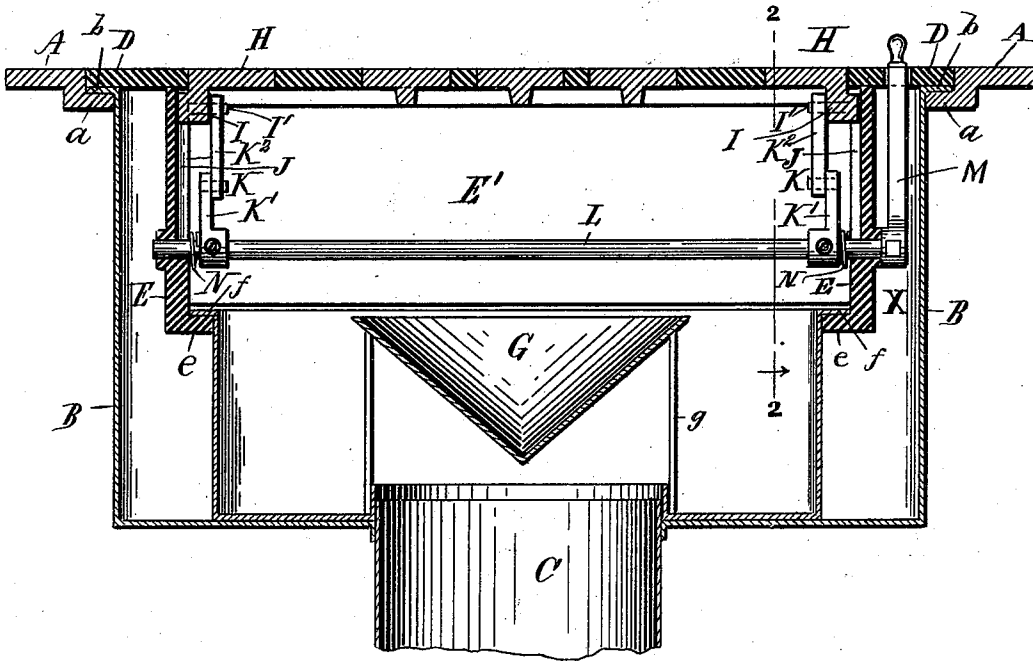
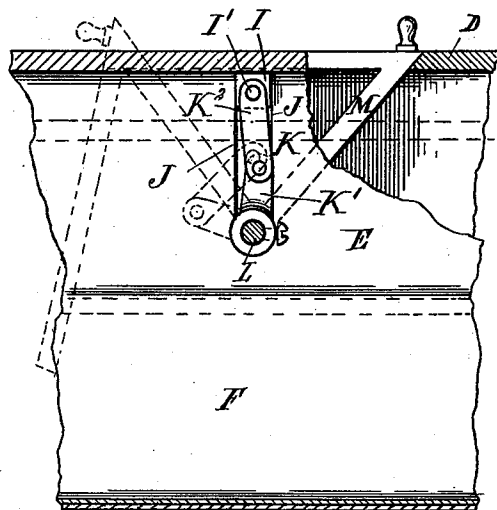

FIG. 2.



Witnesses:
J. Halpenny
George Bell

Inventor:

Walter M. Dyas
 By his attorneys
Girdley & Hopkins

W. M. DYAS.
HOT AIR REGISTER.

No. 522,200.

Patented July 3, 1894.

FIG. 3.

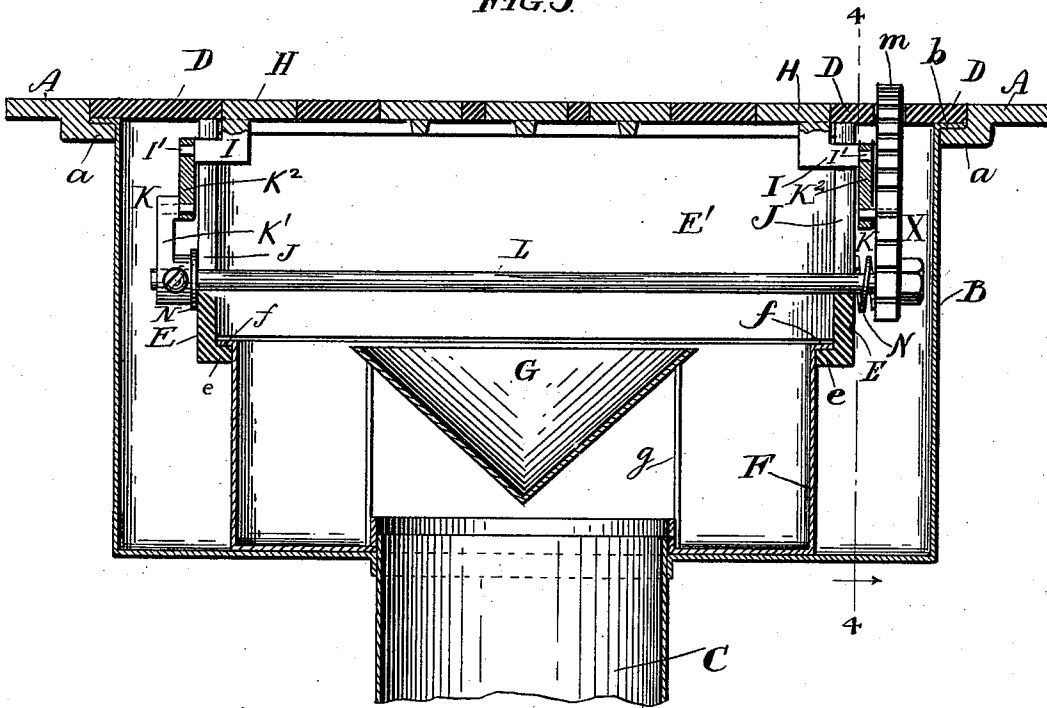
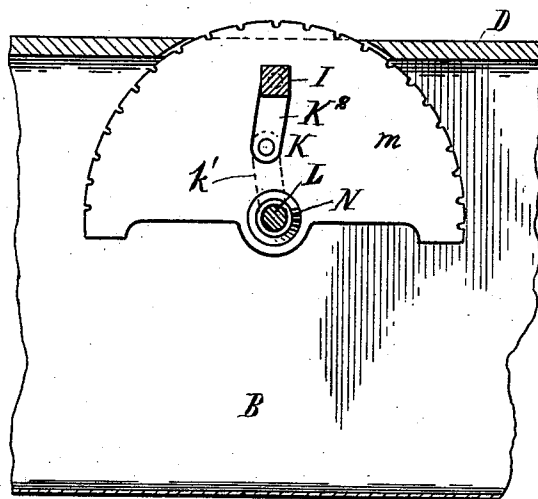

FIG. 4.



Witnesses:

J. Halpernny
George Bell

Inventor:

Webster M. Dyas
By his attorney
Gridley Hopkins

UNITED STATES PATENT OFFICE.

WEBSTER M. DYAS, OF ARLINGTON HEIGHTS, ILLINOIS.

HOT-AIR REGISTER.

SPECIFICATION forming part of Letters Patent No. 522,200, dated July 3, 1894.

Application filed September 30, 1893. Serial No. 486,848. (No model.)

To all whom it may concern:

Be it known that I, WEBSTER M. DYAS, a citizen of the United States, residing at Arlington Heights, in the county of Cook and State of Illinois, have invented certain new and useful Improvements in Hot-Air Registers, of which the following is a specification.

The present invention relates, in part, to a removable pan for catching the dust and dirt that fall through the register, and the object of this part of the invention is to so associate the pan with the removable register that when the latter is lifted out of place the former is carried with it, the nature of the connection between them being preferably such that they may be separated after they are removed.

The invention also relates, in part, to the mechanism for moving one of the plates of the registers of that type in which the register is closed by bringing the two plates together, by a movement of one of them toward the other, and the objects of this part of the invention are to provide means for holding the movable plate in a plane substantially parallel with the fixed plate and to provide toggles for operating the movable plate.

To these ends the invention consists in the novel features that are particularly pointed out in the claims hereinafter, and in order that it may be fully understood I will describe it with reference to the accompanying drawings, which are made a part hereof, and in which—

Figure 1 is a vertical section of a register embodying the invention. Fig. 2 is a vertical section of portions thereof on the line 2—2. Fig. 3 is a vertical section of a register having modified mechanism for operating the movable plate. The mechanism here shown differs slightly from that shown in the preceding figures, but it embodies the invention, and for the purpose of this application it is elected as the preferred form. Fig. 4 is an elevation of a portion thereof.

A represents the register frame, having in its top side and around its inner margin a rabbet, resulting in a depressed horizontal flange *a*, and B represents the permanent register box having in its bottom an opening for receiving the hot air stack C. The upper

margin of the register box B is provided with a simple flange *b* that is turned outward and rests flat upon the flange *a*, forming a flat seat for the margin of the fixed plate D of the register.

Either secured to or integral with the plate D, and extending downward from its under side, are plates or flanges E, the principal office of which is to afford suitable brackets or supports for a rock shaft hereinafter described, but I desire to have it understood that so far as the invention relates to the means for operating the movable plate of the register, it is not limited to supports of this or any other particular form. In addition to their function as supports, these plates or flanges unite with similar flanges E' and form an inner rectangular box which meets the upper margin of the dust pan F, and thereby prevents any considerable amount of dust from escaping into the box B.

The plates E are provided with flanges *e* which project inward, and the dust pan is provided with flanges *f* which project outward and rest upon the flanges *e*, so that when the inner box is lifted out the pan is carried with it. If desired, one of the plates E' may have a flange similar to *e*, and the dust pan may have a flange similar to *f* for engaging it, but the other one of the plates E' must terminate a short distance above the flanges *e* so that the dust pan may be slipped toward that side until the flanges *e* and *f* are disengaged. The pan being then separate from the other parts may be cleaned easily. So far as I am aware, I am the first to attach a dust pan to a register so that when the latter is lifted out the former is carried with it.

G is a receiver attached to the dust pan by legs *g* so that it is directly over the stack C, its office being to prevent dirt from falling into the stack.

H represents the movable plate of the register, and I lugs carried by it and fitting between vertical guides J. I prefer to form these guides by simply slotting the plates E, but if desired they may be independent of said plates, as shown in Patent No. 504,469, which was granted to me September 5, 1893. The lugs are non-circular and fit snugly between the guides, so that they are prevented

from turning, and thereby the movable plate is kept parallel with the fixed plate. The movable plate is operated by toggles K, which in turn are operated by some suitable means, as for example a rock shaft L journaled in the plates E and provided with means whereby it may be operated from above the top plate of the register. As shown in Figs. 1 and 2, the means for operating the rock shaft is a lever M projecting through a slot in the plate D, while in Figs. 3 and 4 is shown a segment *m* having its serrated edge extended through said plate. As shown in Figs. 1 and 2, the toggles consist of arms K', each fixedly secured at one end to the rock shaft L, and links K² each pivotally connected at one end to the outer end of said arm, and at the other to the plate H. A convenient manner of connecting the links K² to the plate H is to perforate them and provide the plate—preferably on the lugs I—with pintles I' occupying said perforations. In Fig. 1 the slots which result in the guides J extend only partly through the plates E, and the pintles I' project inward from the lugs, thereby making it necessary to locate the toggles inside of the plates E, but in Fig. 3 the slots extend quite through the plates and the pintles project outward, thereby enabling the location of the toggles in the space X between the inner and outer boxes of the register. As shown in Figs. 3 and 4, one of the toggles consists of the arm K' and link K², (precisely as shown in Figs. 1 and 2) but the other is without an arm such as K' that is distinct from the segment *m*. Here the segment (or at least so much of it as is indicated by the dotted lines at *k'*) forms one member of the toggle and does the work of the arm K'.

The operation of this mechanism is obvious. By turning the rock shaft in one direction the toggles are straightened and the plate H moved toward the plate D, and by turning it in the other direction the reverse of this takes place. In order to hold the movable plate in any position in which it may be placed—partly closed—a brake is applied to some one of the moving parts. In Figs. 1 and 2 it is shown applied to the member K' of one of the toggles, while in Figs. 3 and 4 it is shown applied to the segment *m*. In each case it consists of a spring washer N formed, preferably, by coiling a strip of flat steel, and while this is preferred, still, any other suitable friction device will answer the purpose.

What I claim as new, and desire to secure by Letters Patent, is—

1. The combination with a removable register, of a dust pan attached to its under side and removable with it, substantially as set forth.

2. The combination with a removable reg-

ister of a dust pan removably attached to its under side, substantially as set forth.

3. The combination with a removable register having on its under side the plates E provided with flanges *e*, of a dust pan having flanges *f* engaging the flanges *e*, the nature of the combination being such that a relative sidewise movement of the register and pan separates them from each other, the flanges *e* and *f* sliding one upon the other, substantially as set forth.

4. The combination with a register having on its under side a box open at bottom, of a dust pan located beneath the register and forming a continuation of the box the dust pan and register being separate structures and separable from each other, substantially as set forth.

5. In a register, the combination with two perforated plates, one of which is movable toward and from the other, the solid portions of one being adapted to register with and close the openings of the other, of plural toggles, one end of each of which engages the movable plate, a rock-shaft with which the other end of each toggle engages, and means for operating said shaft, substantially as set forth.

6. In a register, the combination with two perforated plates, one of which is movable toward and from the other, the solid portions of one being adapted to register with and close the openings of the other, of supporting brackets arranged behind and fixed with relation to the fixed plate, and plural toggles, one end of each of which engages the movable plate and the other end of each of which is pivoted to one of the supporting brackets, and means for operating said toggles, substantially as set forth.

7. In a register, the combination of the fixed plate, the movable plate having the lugs I, guides J engaging said lugs, pintle I' carried by said lugs, a rock-shaft, means for turning it, arms, each secured fixedly at one end to said shaft, and links, each engaging one of said pintles, at one end, and at the other pivoted to the arms of the rock-shaft, said arms and links being arranged to form toggles, substantially as set forth.

8. In a register, the combination with the movable plate thereof, of a rock shaft, toggles connecting the rock-shaft and movable plate, and a segment secured to the shaft and extending through the top plate of the register, said segment having incorporated in it one of the members of one of the toggles, substantially as set forth.

WEBSTER M. DYAS.

Witnesses:

L. M. HOPKINS,
N. C. GRIDLEY.