

C. P. BOWEN.
Amalgamator.

No. 208,509.

Patented Oct. 1, 1878.

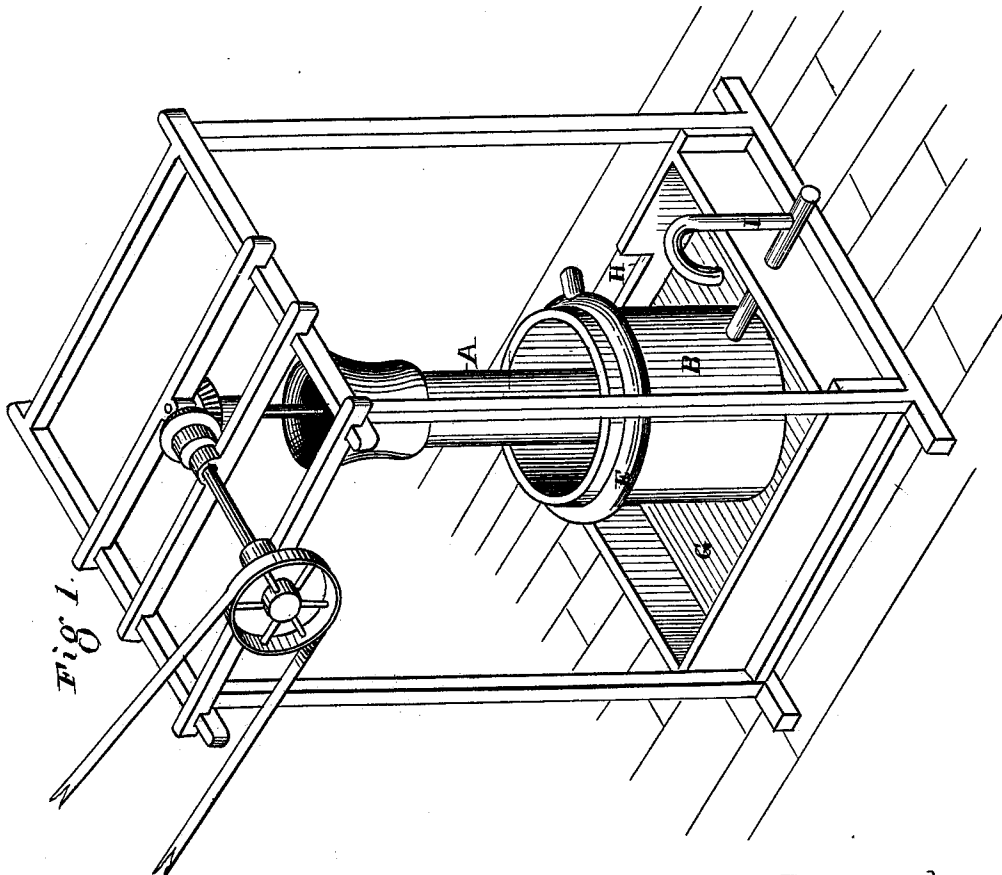
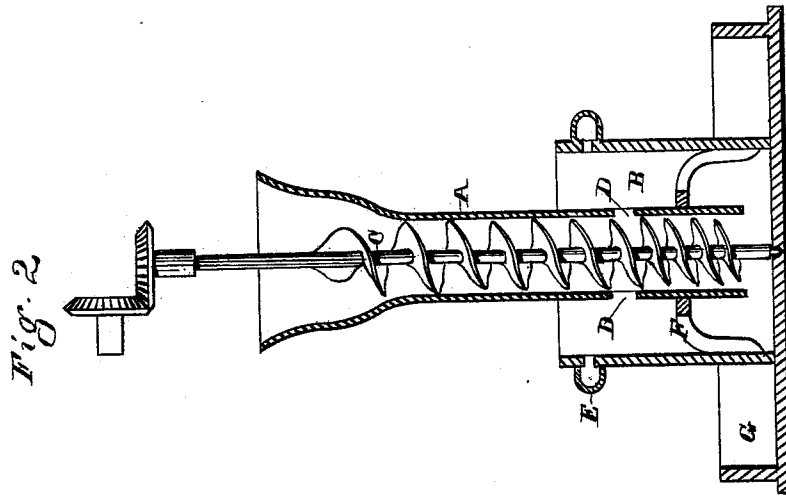

Witnesses
Geo. H. Strong.
Frank W. Brooks

Inventor
Charles P. Bowen
by Dewey & Co.
Attys

UNITED STATES PATENT OFFICE.

CHARLES P. BOWEN, OF SILVER CITY, IDAHO TERRITORY.

IMPROVEMENT IN AMALGAMATORS.

Specification forming part of Letters Patent No. 208,509, dated October 1, 1878; application filed April 22, 1878.

To all whom it may concern:

Be it known that I, CHAS. P. BOWEN, of Silver City, county of Owyhee, and Idaho Territory, have invented an Improved Amalgamator; and I do hereby declare the following to be a full, clear, and exact description thereof, reference being had to the accompanying drawings.

My invention relates to improvements in that class of amalgamators in which the ore is forced into a body of mercury by mechanical means, so as to be thoroughly stirred up with the mercury; and it consists in the use of a receptacle for the mercury, in the center of which is an open-bottomed tube or cylinder, in which a screw revolves, so that when the pulp is forced into the top of the cylinder the screw will force or draw the pulp down through the mercury and discharge it through the bottom of the tube into the mass of mercury, where it rises to the top. Water is admitted around the vessel containing the mercury, which keeps the pulp stirred up and flows it over the edge of the vessel into a tank, whence it is drawn off to the settlers.

It also consists in forming openings in the central tube or cylinder just below the surface of the mercury in the vessel, so that the action of the screw will draw fresh mercury from the vessel into the tube and mix it thoroughly with the pulp, and so keep up a continuous downward current of fresh mercury and pulp through the tube or cylinder in which the screw operates.

Referring to the accompanying drawings, Figure 1 is a perspective view. Fig. 2 is a vertical section.

Let A represent the tube or cylinder into which the ore is fed, said tube or cylinder being secured in an upright position in the center of the vessel B, which contains the mercury, so that the open bottom of the tube is a short distance above the bottom of the vessel B. In the center of the tube or cylinder A is placed a vertical shaft, having formed on that part of it within the cylinder a spiral or screw, C. The shaft and screw are revolved by any appropriate means, and I have shown them in this instance as operated by bevel-gear and pulley - and - belt connections with engine or

other power. The lower end of the tube A is open, and other openings, D, are also formed in said tube at a point about half-way between the top and bottom of the vessel B, for the purpose hereinafter described.

The vessel B has formed around its upper outer edge, just below the top, a circular water-pipe, E, connected with the interior of the vessel by holes or openings, as shown. The tube A is held in an upright position in the vessel B by the collar F, as shown, or by other appropriate means, so as to leave the lower end of the tube open and leave a passage from said tube into the vessel B. The upper end of the tube or cylinder A is enlarged, so as to form a sort of hopper, into which the pulp or crushed ore to be treated is fed. The vessel B is filled with mercury up to within a short distance from where the orifices connecting with the water-pipe F are formed, and the mercury will then flow up into the tube A through the openings at the bottom of the tube, and attain the same level as in the vessel B. As the pulp is fed in at the upper end of the tube A, the action of the screw C, by its rotation, draws or forces the pulp down through the mercury in the tube, so that all the particles of precious metal are brought in direct contact with the mercury and thereby amalgamated. The pulp thus drawn or forced down by the screw is discharged from the tube A through the opening at the bottom of said tube, and rises through the body of mercury in the vessel B to the surface, the precious metal contained in said pulp having been amalgamated in its passage through the mercury. The pulp on rising to the surface of the mercury, by reason of its lesser density, is kept stirred up and loose by the stream of water entering from the openings in the vessel B connecting with the water-pipe E around the vessel. The pulp and muddy water then flow over the upper edges of the open vessel B into the tank G, in which the vessel B stands, whence it is drawn off through a gate, H, into the settlers, where all the precious contents which may have flowed over with it are caught.

A trap, I, is connected with the vessel B, so that in case of any increase of bulk in the mercury the surplus will flow out of the trap

I into a proper receptacle, instead of getting into the water-pipe E through the openings in the vessel connecting with said pipe.

The openings D in the middle of the tube A are formed just below the level of the surface of the mercury in the vessel, and the action of the screw draws in fresh mercury through these openings, mixing and stirring it up with the pulp, and keeping a continuous flow of mercury downward through the tube with the pulp. In this way all the particles of precious metal are brought in direct contact with the mercury and amalgamated. The action of the screw, while stirring and mixing the pulp and mercury together and forcing the pulp down through the mercury, is not sufficiently rapid to "flour" the quicksilver—that is, it does not break it up into globules so fine that they will float, as is the case when mercury is ground or violently agitated.

The operation of this device is continuous, the pulp passing in the tube and out over the top of the vessel, as described, the water assisting in keeping said pulp loose and free, so as to allow every particle of the precious metal to come in contact with the mercury and be amalgamated with it. The supply of pulp and one of these amalgamators can be used in connection with several settlers.

The action of the device is such that the precious metals in the pulp are brought in direct contact with the mercury as the pulp passes down and up through the mercury, so that no particles of gold or silver are lost. The

mercury is always bright and in a condition to perform its offices, which is not the case where it is distributed over a copper surface exposed to the air.

Having thus described my invention, what I claim as new, and desire to secure by Letters Patent, is—

1. The tube A, extending to near the bottom of the exterior mercury-containing vessel B, said tube having the perforations D just below the surface of the mercury, in combination with the feeding-screw C, whereby the material is fed downward and a circulation of mercury is kept up, substantially as shown, and for the purpose herein described.

2. The perforated tube A, with its feeding-screw C, and the exterior mercury-containing vessel B, in combination with the surrounding water-pipe E, with its interior perforations, to discharge water into the pulp above the mercury, substantially as shown, and for the purpose herein described.

3. The perforated tube A, extending to near the bottom of the mercury-containing vessel B, provided with the water-supply pipe E, in combination with the mercury-trap I, substantially as shown, and for the purpose herein described.

In witness whereof I hereunto set my hand and seal.

CHAS. P. BOWEN. [L. S.]

Witnesses:

GEO. H. STRONG,
FRANK A. BROOKS.