

W. CHRISTIAN.

Improvement in Spoke-Sockets for Carriage-Wheels.

No. 131,082.

Patented Sep. 3, 1872.

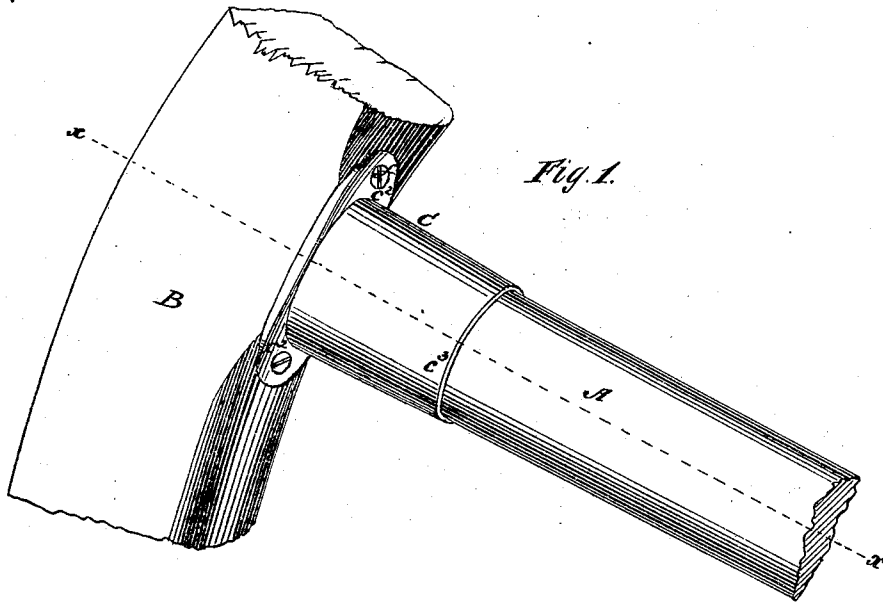

Fig. 1.

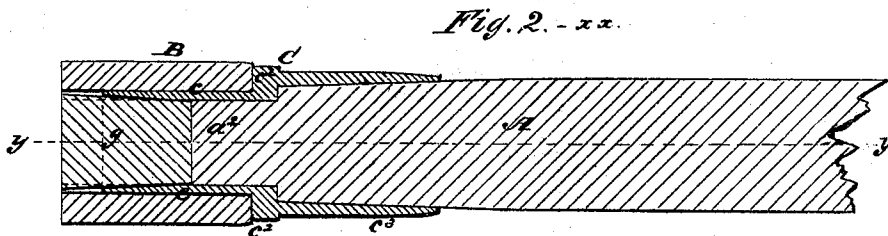

Fig. 2.-xx.

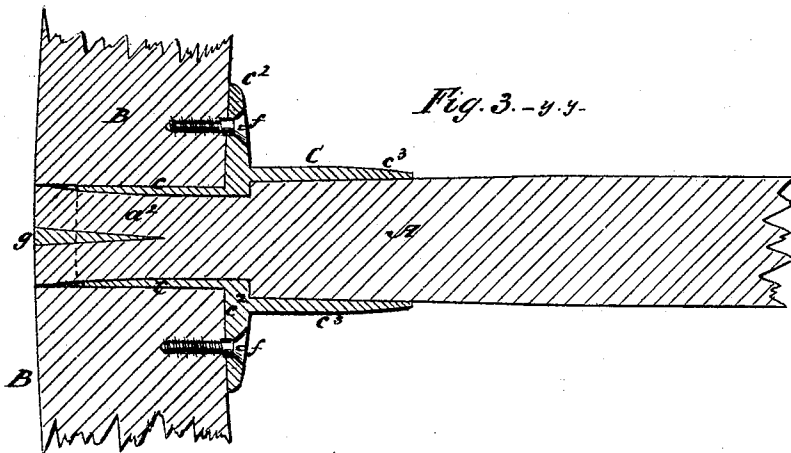

Fig. 3.-y-y.

Witnesses,  
J. Felber.  
E. Wolff.

Inventor:  
William Christian.  
By attorney  
J. Mc Intire.

# UNITED STATES PATENT OFFICE.

WILLIAM CHRISTIAN, OF NEW YORK, N. Y.

## IMPROVEMENT IN SPOKE-SOCKETS FOR CARRIAGE-WHEELS.

Specification forming part of Letters Patent No. 131,082, dated September 3, 1872.

### SPECIFICATION.

*To all whom it may concern:*

Be it known that I, WILLIAM CHRISTIAN, of New York, of the county of New York, in the State of New York, have invented certain new and useful Improvements in the Construction of Carriage-Wheels; and I do hereby declare that the following is a full and exact description thereof, reference being had to the accompanying drawing making part of this application.

Previous to my invention one of the greatest difficulties encountered in the manufacture and use of spoked wheels has arisen from the tendency of the spoke to wear and break at the point where it enters the felly, and various remedies for this evil have been suggested, among which are some in which metallic sleeves and shoe-pieces, sockets, &c., have been employed; but I am not aware of any perfectly-successful preventive for the difficulty alluded to having been applied.

My invention has for its object to overcome this difficulty and provide a mode of construction for wheels which shall render them stronger and more lasting, and without materially increasing their weight or cost of manufacture; and to these ends my invention consists in the employment, in combination with the felly and spoke, of a metallic socket or holder which is so constructed with a sleeve entering the hole in the felly, a sleeve surrounding the inserted end of the spoke, and a flanged portion bearing on the inner face or circumference of the felly as to firmly unite all the parts, in the manner to be hereinafter more fully explained.

To enable those skilled in the art to make and use my invention I will proceed to describe the construction and operation of the same, referring by letters to the accompanying drawing, in which—

Figure 1 is a perspective view of portion of a wheel made according to my improved plan. Fig. 2 is a section at the line *x x*, Fig. 1; and Fig. 3 is a section in the same direction as, but in a plane at right angle to, that of the section seen at Fig. 3.

In the several figures the same part is designated by the same letter of reference.

A is the spoke, and B the felly, of a carriage-wheel, and C is a metal socket-piece or securing-sleeve by means of which the spoke A and felly B are retained together, as will be presently explained. The socket-piece C may be

made of malleable iron; its form (as is clearly illustrated) is that of two cylinders, of different diameters, uniting in a central flanged portion. The felly B is bored through simply, (with a hole of uniform diameter throughout its length,) and the socket-piece is made so that the smaller cylindrical portion or the sleeve part *c* will fit snugly into said hole in the felly and extend part way of its length, and so that when placed in the hole of the felly the flanged portion *c*<sup>2</sup> will come up against and bear upon the inner face or circumference of B, as shown. This flanged portion *c*<sup>2</sup> is pierced with holes in which are inserted small screws or bolts *f f*, which are screwed into the felly B. The sleeve portion *c*<sup>3</sup> is of greater diameter than the part *c*, and its internal diameter (or size) is reduced by a square shoulder, as shown, at about the plane of the flange portion *c*<sup>2</sup>, and the spoke A is so made that its tenon portion *a*<sup>2</sup> fits snugly into the portion *c* of the metal socket, and its shoulder comes to a bearing on the shoulder of said metal piece, while the sleeve part *c*<sup>3</sup> of the retaining-socket snugly embraces or surrounds the body-portion of the said spoke. The usual wedge is inserted to make it fill the hole in the felly and prevent its drawing out or getting loose. As already remarked, the portion *c* of the metal sleeve-piece fits snugly in the hole in the felly, but extends in length a distance less than the length of the hole in (or less than the thickness of) the felly, and the end of the spoke is expanded by the wedge *g* to fill the hole in the felly. It will be observed that the wedging of the end of the spoke expands the wood to tightly fill that portion of the hole in the felly not occupied by any part of the metal sleeve *c*, and it will be understood that this is necessary and important, since, if the sleeve *c* extended the whole length of the hole in the felly, and the spoke were wedged tightly only in this metal sleeve, the desired ends would not be fully attained, because, if all the castings did not fit tight in the felly, or in the event of any shrinkage of the felly, (after they were fitted in tight,) the ends of the spokes and the metal sleeves in which they were secured would be liable to rattle; and, further, the whole structure would not be so strong, mutually sustaining the several parts, nor so durable. The flange portion *c*<sup>2</sup> of the metal socket-piece, it will be seen, takes a good bearing on the inner face of the felly B; this flange may extend at each side of the spoke (in the direction of the

felly) to a considerable distance, and by the screws *f* the said metal piece is prevented from turning or moving laterally. It will be understood that the metal socket-piece is securely held endwise in the felly by the spoke, the wedging at *g*, and the screws *f*, while it is retained against turning round by the said screws and by the spoke, (when the latter is not circular in cross-section;) and it will be seen that as the sleeve *c*<sup>3</sup> surrounds the spoke for some distance beyond the tenon, and the shoulder formed thereby, there is no possibility of the spoke giving way at the tenoned part; and it will be seen that by the combination of the felly, spoke, and interposed metal socket or sleeve piece, as shown and described, a far greater degree of strength and durability is attained in the whole structure than could exist without the use of the metal portion *c*, or its equivalent.

I have shown the metal portion made of a shape and size which I have used successfully on heavy work, but it will be understood, of course, that the proportions and even the shape may be varied with varying circumstances, and to suit the wishes of the manufacturers or builders of wheels of various kinds without departing from the spirit of my invention, the first of which rests in the employment, in connection with the spoke and felly, of a metal strengthener or holder which enters and extends part

way through the hole in the felly, and embraces or surrounds the spoke in such a manner as to afford a re-enforce or strengthener at the point where the spoke enters the felly; and in so combining the parts shown that they are all interlocked, as described, to render the whole structure strong and durable; and it will be seen that a great part of the advantage of my new mode of construction of wheel may be gained even when the flanged portion *c*<sup>2</sup> is entirely dispensed with, though in most cases I propose to employ this flanged portion in making the metal parts of the wheel, as I deem it an auxiliary to the structure, and useful.

Having fully explained my new method of constructing wheels, what I claim as new, and desire to secure by Letters Patent, is—

In combination with the spoke and felly, a metal socket or sleeve piece constructed as described, and extending only partially through the felly, so that the expansion of the spoke by the wedge will fill that portion of the hole in the felly not occupied by any part of the metal sleeve, thus firmly uniting all the parts together.

In testimony whereof I have hereunto set my hand and seal this 5th day of March, 1872.

WILLIAM CHRISTIAN. [L. S.]

In presence of—

GEO. A. GREENSWARD,  
J. N. McINTIRE.