



US00D402951S

# United States Patent [19]

[11] Patent Number: **Des. 402,951**

Wechner

[45] Date of Patent: **\*\*Dec. 22, 1998**

[54] **FRONT FACE OF A MOTOR VEHICLE WHEEL**

D. 344,924	3/1994	Braungart et al.	.....	D12/211
D. 363,910	11/1995	Chung	.....	D12/209
D. 375,075	10/1996	Kugler	.....	D12/209

[75] Inventor: **Daniel Wechner**, Munich, Germany

### OTHER PUBLICATIONS

[73] Assignee: **Bayerische Motoren Werke Aktiengesellschaft**, Munich, Germany

1994 Custom Wheel and Tire Style Guide, See "Centra Type 22" Wheel, p. 37 and p. 244 Wheel, p. 34.

[\*\*] Term: **14 Years**

*Primary Examiner*—James Gandy  
*Assistant Examiner*—Stacia Sinuik  
*Attorney, Agent, or Firm*—Evenson, McKeown, Edwards, & Lenahan PLLC

[21] Appl. No.: **79,696**

[22] Filed: **Nov. 21, 1997**

### [30] Foreign Application Priority Data

May 21, 1997 [DE] Germany ..... M 97 04 929.8

### [57] CLAIM

The ornamental design for a front face of a motor vehicle wheel, as shown and described.

[51] **LOC (6) Cl.** ..... **12-16**

[52] **U.S. Cl.** ..... **D12/211**

### DESCRIPTION

[58] **Field of Search** ..... D12/204-213;  
301/64.1, 65, 37.1

FIG. 1 is a side view of a front face of a motor vehicle wheel according to my novel design; and, FIG. 2 is a side perspective view of a front face of a motor vehicle wheel according to my novel design.

The dash line showing depicts environment and is not part of the claimed design.

### [56] References Cited

#### U.S. PATENT DOCUMENTS

D. 203,931	3/1966	Hibbard	.....	D12/211
D. 268,750	4/1983	Eichstadt	.....	D12/209
D. 339,561	9/1993	Maiworm et al.	.....	D12/211

**1 Claim, 1 Drawing Sheet**

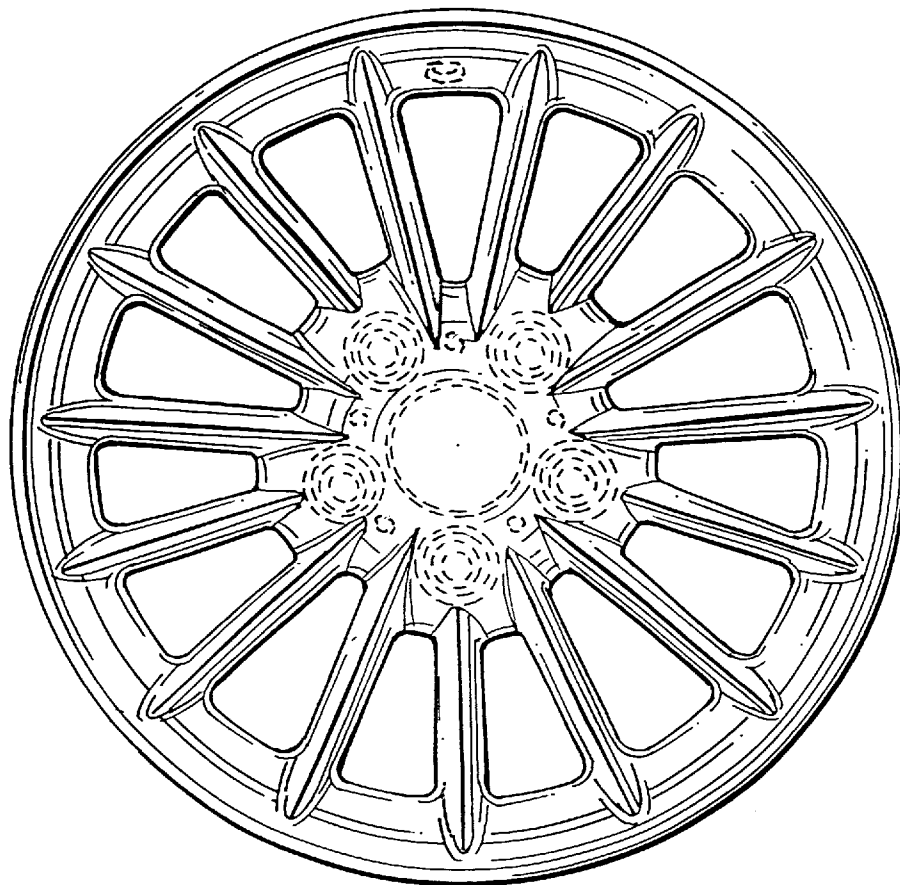

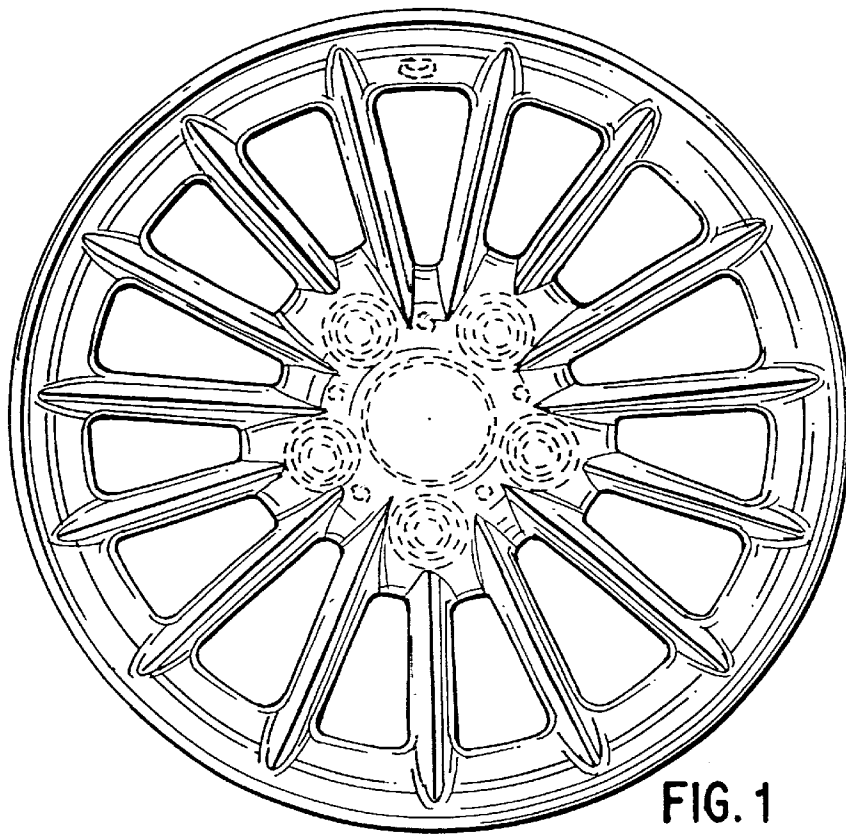

FIG. 1

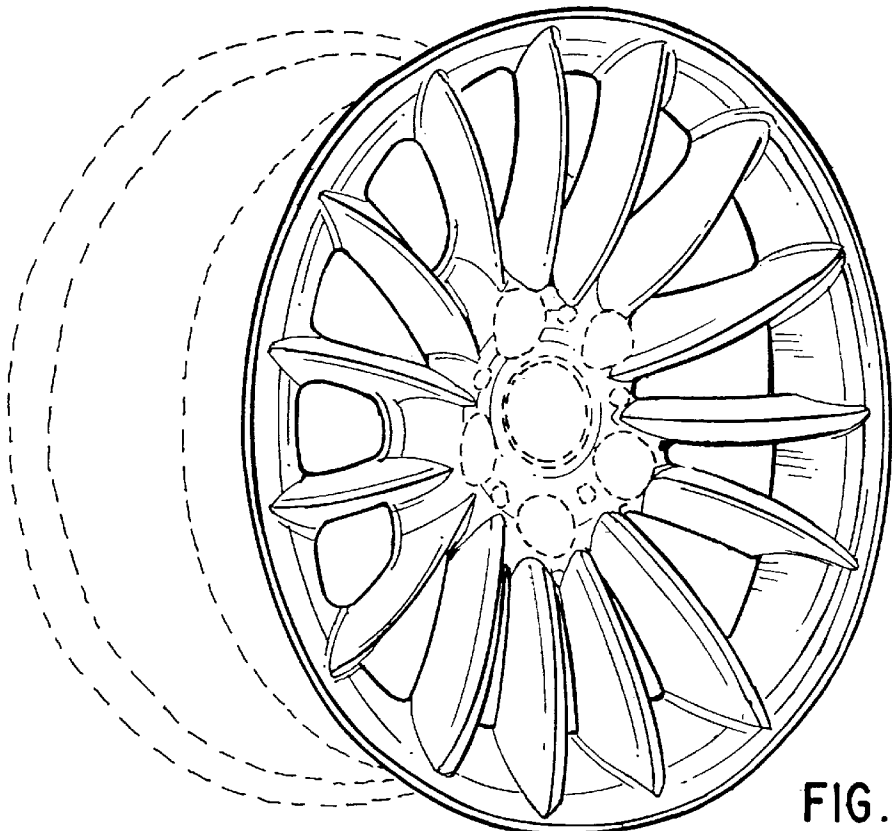

FIG. 2