

S. D. CUSHMAN.
 SIGNAL BOX FOR FIRE ALARM TELEGRAPH.

No. 103,150.

Patented May 17, 1870.

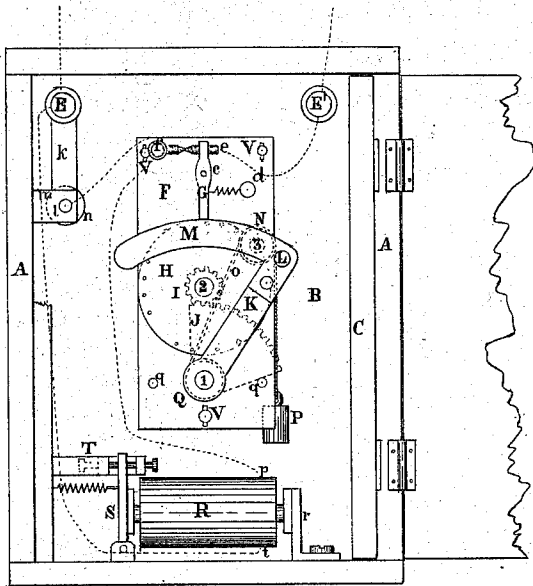

Fig. 1.

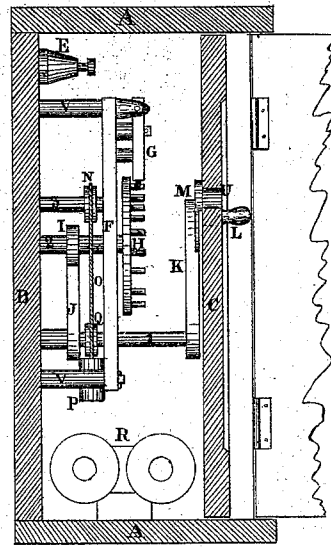

Fig. 2.

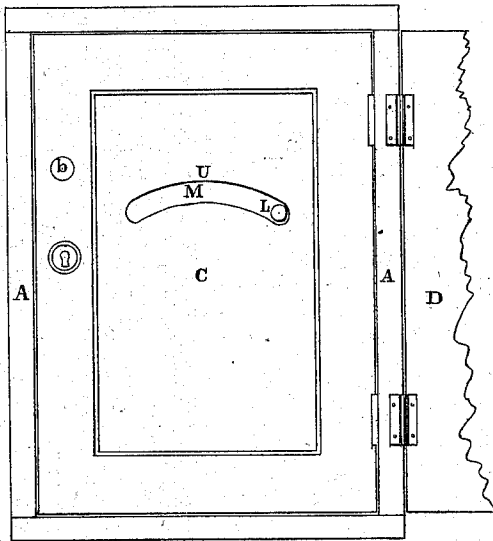

Fig. 3.

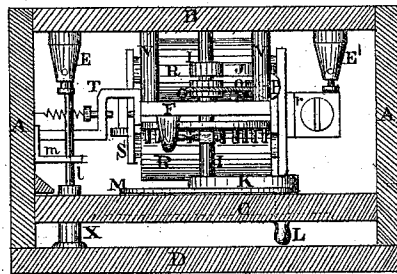
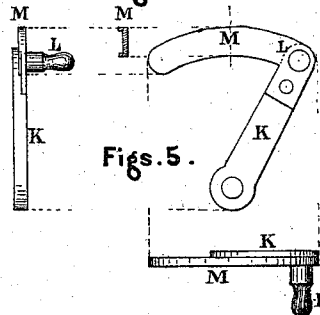

Fig. 4.



Figs. 5.

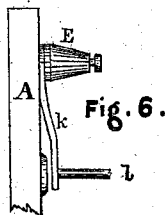

Fig. 6.

Andrew Chaffin
Ruth L. Abbott Witnesses.

Sylvanus D. Cushman Inventor.
J. J. Abbott Attorney.

United States Patent Office.

SYLVANUS D. CUSHMAN, OF NEW LISBON, ASSIGNOR TO THE AUTOMATIC FIRE-ALARM COMPANY, OF LEETONA, OHIO.

Letters Patent No. 103,150, dated May 17, 1870.

IMPROVEMENT IN SIGNAL-BOXES FOR FIRE-ALARM TELEGRAPHS.

The Schedule referred to in these Letters Patent and making part of the same.

To all whom it may concern:

Be it known that I, SYLVANUS D. CUSHMAN, of New Lisbon, Columbiana county, Ohio, have invented certain new and useful Improvements in Signal-boxes for Fire-alarm Telegraphs; and that the following is a full, clear, and exact specification thereof.

Nature and Objects of the Invention.

The first part of my invention relates to the construction of a winding-lever for an automatic fire-alarm apparatus, with a handle or knob of a sufficient length to extend through a slot in the inner door of the signal-box when closed, by means of which said winding-lever may be separated from the outside of said inner door, whereby the use of any sliding or rotating actuator secured on the inner door, and actuating the winding-lever is dispensed with, and the danger of bending the winding-lever in shutting the inner door is wholly obviated.

The second part of my invention relates to the construction of a winding lever for an automatic fire-alarm apparatus, with a knob or handle extending through a slot in the inner door of the box, and with a covering piece working close up to or against said inner door when closed, and covering the slot in said door, through which the said knob or handle projects, for the purpose of keeping dust and dirt from blowing into said slot.

The third part of my invention relates to the construction of a signal-box for fire-alarm telegraphs, with an automatic fire-alarm apparatus, and with a switch mechanism, so constructed and arranged as that the shutting of the outer door of the signal-box switches the electro-magnets out of the telegraph circuit, but leaves the automatic mechanism in the circuit, whereby the person giving the alarm can close the signal-box after drawing up the automatic mechanism, and leave it before the alarm is completed, whenever it is necessary, and still have the electro-magnets switched out when the signal-box is closed, thus effecting a great saving of battery power, and protecting the electro-magnets from injury by atmospheric electricity.

Description of Accompanying Drawings.

Figure 1 is a front view of a signal-box, embodying my invention, with both doors open.

Figure 2 is a side view of the same, with the inner door closed, and one side of the box cut away.

Figure 3 is a front view of the same, with inner door closed.

Figure 4 is a plan of the same, with both doors closed, and the top of the box cut away.

Figures 5 are elevation, side view, and plan of winding-lever, with knob and covering piece.

Figure 6 is a side view of the switch device.

General Description.

A represents the box-frame, which may be made in any suitable form, and of wood or metal, as found desirable.

The inner door C is hinged on the box A, a little back of the outer door D, as shown in figs. 2 and 4, and the back B is conveniently made separate from the frame A, so that it may be easily removed for repairing the automatic mechanism.

The posts V V V are secured in the back B, and have the plate F secured at their other ends, and the shafts 1, 2, and 3, are journaled in said back and plate, as shown.

The gear-sector J is secured on the shaft 1, and meshes into the pinion I on the shaft 2, on which shaft is also secured the circuit-wheel H.

The pulley Q is secured to the shaft 1, and has attached to it the cord O, which passes up over the pulley N on the shaft 3, and has the weight P attached at its end, as shown.

The key G is journaled on a standard, e, in the plate F, and has the pin e secured in its upper end, which pin is pressed against a pin in the standard f, secured in the plate F, by the action of a spiral spring attached to the key G and to the pin d, as shown in fig. 1.

Pins are arranged in the face of the circuit wheel H in a manner depending on the particular signal required, and a sliding rod with beveled lower end is arranged in the key G, so that, as the circuit-wheel H is revolved from left to right by the movement of the gear-sector J, from right to left in drawing up the weight P, the pins in the circuit-wheel H strike the beveled end of the sliding rod in the key G and raise it up, so as to allow of their passing said rod without vibrating said key, and thus breaking the circuit, while in the automatic rotation of the circuit-wheel H, from right to left by the action of the weight P, the pins in said circuit-wheel strike the square side of the rod in the key G, thus vibrating said key, and breaking the circuit by drawing the pin e back from the pin in the standard f, as is readily seen.

Stop-pins q q are secured in the back B for the purpose of limiting the movement of the gear-sector J, and consequently the rotations of the circuit-wheel H.

The general construction of this automatic mechanism is the same as that shown in Letters Patent granted to Alexander Allen, for an improved automatic fire-alarm apparatus, on the 1st day of June, 1869, and bearing No. 90,806, to which reference is made for a more complete description.

The front end of the shaft 1 extends through the plate F, out to the inner door C, and on it is secured the winding-lever K.

The slot U is cut in the door C, and is of the same curvature as that of the circle described by the end of the winding-lever K, the center of its circle of curvature being in the axis of the shaft 1, as is readily seen.

In order to operate the winding-lever K when the inner door C is closed, I secure the knob or handle L in the end of the lever K, and make it of a sufficient length, so that it shall project through the slot U in the inner door C, as seen in figs. 2 and 4, so that, by grasping said knob on the outside of the door C, the lever K can be drawn back to wind up the automatic mechanism, as is readily seen.

To prevent dust and dirt from blowing into the slot U of the inner door C, I secure the covering plate M to the inner side of the winding-lever K, as shown in fig. 5, said plate being formed to the same curve as that of the slot V, and working close up to the inner door C, as shown in figs. 2 and 4, so that it completely covers the slot V, as shown in fig. 3.

This plate is conveniently made of brass or any cast metal, or it can be cut from sheet metal, if preferred, and flanges may be formed along its edges, as shown in section M in figs. 5, to give it considerable lateral stiffness, so as to prevent it from being bent, and thus injuring its perfect contact with the door C.

The electro-magnet R is secured on the standard *r* on the bottom of the box A, and has arranged with it the pivoted armature S, provided with a tension-spring, and controlled by screws in the standard T in an ordinary manner.

The screw-cups E E', in which are secured the ends of the main circuit wire, are arranged in the upper part of the back B, as shown, and an insulated wire connects the screw-cup E' with the pin *e* in the key G.

An insulated wire connects the standard *f*, with one end of the wires on the electro-magnets R, at *p*, and the other end, *t*, of the wire on said electro-magnets is connected by an insulated wire with the screw-cup E, said insulated connecting wires being indicated by dotted lines in fig. 1, from which it is seen that when no switches are in operation the electric circuit through the box is from the screw-cup E', through the automatic key mechanism *e f* and electro-magnets R, to the screw-cup E, so that, if the automatic mechanism be put in operation, the electrical circuit will be broken, as required, to transmit the required signal, and the electro-magnet R, with its armature S, will indicate, by its audible action to the operator, whether the circuit is in working order, and whether the signal is being properly transmitted.

In order to switch the electro-magnets out of the circuit by the closing of the door, I secure the elastic plate *k* under the screw-cup E, and place under it the anvil *n*, which is connected by an insulated wire with the standard *f*, as shown in fig. 1.

The rod *l* is secured to the plate *k*, and passes through a hole in the bracket *m*, which is secured on the frame A A, and the push-knob X is secured on the outer door D, and shuts through a hole, *b*, in the inner door C against the rod *l*, as shown in fig. 4, thus pressing the plate *k* against the anvil *n* when the outer door D is closed.

From this description it is seen that when the outer

door D is opened the plate *k* springs away from the anvil *n*, thus opening the switch and causing the current to traverse the circuit E' *e f p t* E, and bringing both the automatic mechanism and electro-magnets into the main circuit; but, if the outer door door D be closed, the switch will be closed, and the current will traverse the shorter circuit E' *e f n k* E, thus cutting the electro-magnets out of the circuit, and leaving the automatic mechanism in said circuit, as is readily seen.

It is also evident that the same plan of switching out the electro-magnets only could be used in boxes provided with a mechanical or key-operating mechanism, instead of an automatic mechanism; but that in such cases it would be of little use, as the operating mechanism would only operate when the door was open, so that the mechanism could be manipulated by the operator, so that it might as well be out of as in the circuit when the door was closed.

I am aware that switches have been applied to signal boxes which were operated by the closing of the door of the signal-box; hence, I lay no claim to the application of a switch to a signal-box, nor to operating the same by the door of the box, except when said switch is so arranged as to switch out the electro-magnets, and leave the operating mechanism in the circuit by the closing of the door, as is herein shown; nor do I claim the covering-piece for covering the slot in the inner door, except when the same is secured to the winding-lever, as is herein shown.

Claims.

What I claim as my invention, and desire to secure by Letters Patent, is—

1. Extending the knob or handle L of the winding-lever K of an automatic fire-alarm mechanism through the slot U in the inner door C of the signal-box, for the purpose of enabling the operator to grasp said knob or handle on the outside of the door C, and thus operate the winding lever, substantially as is herein specified.

2. The covering-piece M, secured on the winding-lever K, and operating in connection with the slot U in the door C, substantially as is herein specified.

3. The combination of the screw-cup E', anvil *n*, electrically connected with the screw-cup E' by an electrical circuit through the automatic apparatus *f G H*, spring *k*, screw-cup E, rod *l*, and outer door D, with push-knob X, the several parts being arranged substantially as and for the purpose specified.

4. A signal-box for fire-alarm telegraphs, provided with suitable operating mechanism and with a switch mechanism, so constructed and arranged as that the closing of the outer door of the signal-box acts to switch the electro-magnets out of the main circuit, but leaves the operating mechanism in said circuit, whether said operating mechanism be or be not automatic, as is hereinbefore specified.

As evidence of the foregoing, witness my hand this 23d day of March, 1870.

S. D. CUSHMAN.

Witnesses:

JOB ABBOTT,
ALEX. ALLEN.