



US00D708666S

(12) **United States Design Patent**
Moertl

(10) **Patent No.:** **US D708,666 S**

(45) **Date of Patent:** **** Jul. 8, 2014**

(54) **DISPENSER**

DESCRIPTION

(75) Inventor: **Reid C. Moertl**, Germantown, WI (US)

(73) Assignee: **Glue Dots International, LLC**,
Germantown, WI (US)

(**) Term: **14 Years**

(21) Appl. No.: **29/406,834**

(22) Filed: **Nov. 18, 2011**

(51) **LOC (10) Cl.** **19-02**

(52) **U.S. Cl.**

USPC **D19/69**

(58) **Field of Classification Search**

USPC D19/66, 67, 68, 69, 70; 156/523, 257,
156/540, 577; 206/411; 225/6, 25, 39, 77;
242/588, 588.1, 588.2, 588.3, 588.6, 5

See application file for complete search history.

(56) **References Cited**

U.S. PATENT DOCUMENTS

2,276,297 A 12/1938 Flood
2,373,062 A 4/1945 Stahly

(Continued)

FOREIGN PATENT DOCUMENTS

DE 2362897 6/1975
DE 4319023 9/1994

(Continued)

Primary Examiner — Austin Murphy

(74) *Attorney, Agent, or Firm* — Reinhart Boerner Van
Deuren s.c.

(57) **CLAIM**

The ornamental design for a dispenser, as shown and
described.

FIG. 1 is an isometric view of an embodiment of the claimed
design;

FIG. 2 is a front view of the claimed design of FIG. 1;

FIG. 3 is a back view of the claimed design of FIGS. 1 and 2;

FIG. 4 is right side view of the claimed design of FIGS. 1-3;

FIG. 5 is a left side view of the claimed design of FIGS. 1-4;

FIG. 6 is a top view of the claimed design of FIGS. 1-5;

FIG. 7 is a bottom view of the claimed design of FIGS. 1-6;

FIG. 8 is an isometric view of a second embodiment of the
claimed design;

FIG. 9 is a front view of the claimed design of FIG. 8;

FIG. 10 is a back view of the claimed design of FIGS. 8 and
9;

FIG. 11 is a right side view of the claimed design of FIGS.
8-10;

FIG. 12 is a left side view of the claimed design of FIGS. 8-11;

FIG. 13 is a top view of the claimed design of FIGS. 8-12;

FIG. 14 is a bottom view of the claimed design of FIGS. 8-13;

FIG. 15 is an isometric view of a third embodiment of the
claimed design;

FIG. 16 is a front view of the claimed design of FIG. 15;

FIG. 17 is a back view of the claimed design of FIGS. 15 and
16;

FIG. 18 is a right side view of the claimed design of FIGS.
15-17;

FIG. 19 is a left side view of the claimed design of FIGS.
15-18;

FIG. 20 is a top view of the claimed design of FIGS. 15-19;
and,

FIG. 21 is a bottom view of the claimed design of FIGS.
15-20.

The ornamental design which is claimed is shown in solid
lines in the drawings. The broken lines and unshaded surfaces
in the drawings are for illustrative purposes only and form no
part of the claimed design.

The ornamental design which is claimed is shown in solid
lines in the drawings. The broken lines and unshaded surfaces
in the drawings are for illustrative purposes only and form no
part of the claimed design.

1 Claim, 9 Drawing Sheets

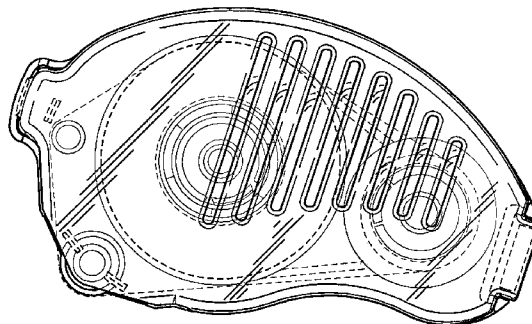
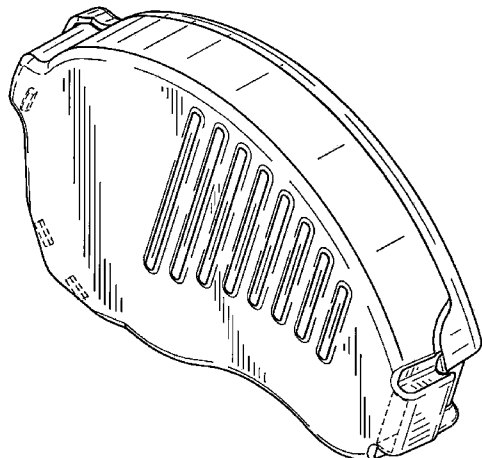

(56)

References Cited

U.S. PATENT DOCUMENTS

2,373,092 A	4/1945	Avery	5,683,545 A	11/1997	Goodwin et al.
2,647,843 A	8/1953	Bemmels	5,685,944 A	11/1997	Nose et al.
2,764,694 A	9/1956	Kinzer	5,738,755 A	4/1998	Hartman
2,838,171 A	6/1958	Kaspar	5,749,994 A	5/1998	Sundet
2,879,547 A	3/1959	Morris	5,779,852 A	7/1998	Haney et al.
2,912,140 A	11/1959	Cole	5,875,715 A	3/1999	Hamisch, Jr. et al.
3,066,881 A	12/1962	Krueger	5,906,443 A	5/1999	Goodwin et al.
3,225,916 A	12/1965	Field et al.	5,910,227 A	6/1999	Mistyurik et al.
3,239,403 A	3/1966	Williams et al.	5,934,189 A	8/1999	Mistyurik et al.
3,267,623 A	8/1966	Block	5,935,670 A	8/1999	Downs
3,308,002 A	3/1967	Bremer et al.	5,988,249 A	11/1999	Mistyurik et al.
3,445,263 A	5/1969	Alexander	6,102,098 A	8/2000	Randazzo
3,457,919 A	7/1969	Harbard	6,143,105 A	11/2000	Nash et al.
3,464,883 A	9/1969	Moline et al.	D436,625 S *	1/2001	Katami D19/69
3,567,148 A	3/1971	Ottavan	6,171,439 B1	1/2001	Grueneweg
3,582,438 A	6/1971	Harbour	6,206,072 B1	3/2001	Orihara et al.
3,595,204 A	7/1971	McIntyre et al.	6,230,780 B1	5/2001	Rietheimer
3,619,324 A	11/1971	Sato	6,280,565 B1	8/2001	Underwood
3,736,281 A	5/1973	Russell	6,319,442 B1	11/2001	Downs
3,741,486 A	6/1973	Kawamata	D456,450 S *	4/2002	Kimura D19/69
3,741,786 A	6/1973	Torrey	6,363,990 B1	4/2002	Kozaki
3,877,959 A	4/1975	Weiss	6,433,055 B1	8/2002	Kleyer et al.
3,881,041 A	4/1975	Glienke	6,439,289 B1	8/2002	Schlotthauer
3,932,326 A	1/1976	Hoh et al.	6,527,888 B2	3/2003	Williams et al.
3,932,328 A	1/1976	Korpman	D476,035 S *	6/2003	Katami D19/69
3,956,223 A	5/1976	Chiang et al.	6,634,400 B2	10/2003	Barbosa
3,969,181 A	7/1976	Seabold	6,640,864 B2	11/2003	Downs
3,997,702 A	12/1976	Schurb et al.	6,686,016 B2	2/2004	Downs
4,002,794 A	1/1977	Schwarz	D494,221 S *	8/2004	Suzuki D19/69
4,100,852 A	7/1978	Hamisch, Jr.	D527,766 S *	9/2006	Mitsui et al. D19/69
4,116,746 A	9/1978	Hamisch, Jr.	D559,912 S *	1/2008	Kai et al. D19/69
4,211,805 A	7/1980	Chamberlin	D571,402 S *	6/2008	Kai et al. D19/69
4,272,311 A	6/1981	D'Angelo et al.	D574,431 S *	8/2008	Kouda D19/69
4,294,357 A	10/1981	Stevens et al.	D577,771 S *	9/2008	Kouda D19/69
4,387,831 A	6/1983	McNally	D594,904 S *	6/2009	Kai et al. D19/69
4,440,830 A	4/1984	Wempe	D595,774 S *	7/2009	Kouda D19/69
4,452,667 A	6/1984	Chang	D598,956 S *	8/2009	Matsushita et al. D19/69
4,470,864 A	9/1984	Haden, Jr. et al.	7,776,173 B2	8/2010	Schumacher et al.
4,508,588 A	4/1985	Parrish	7,837,815 B2	11/2010	Downs et al.
4,537,934 A	8/1985	Fock et al.	7,927,450 B2	4/2011	Spaulding et al.
4,543,099 A	9/1985	Bunnelle et al.	8,006,734 B2	8/2011	Hajny et al.
4,560,087 A	12/1985	Sato et al.	D645,513 S *	9/2011	Mitsui et al. D19/69
4,562,102 A	12/1985	Rabuse et al.	2002/0059984 A1	5/2002	Goodwin et al.
4,699,685 A	10/1987	Sato	2003/0056869 A1	3/2003	Tate et al.
4,718,971 A	1/1988	Summers	2003/0084987 A1	5/2003	Rodriguez et al.
4,719,261 A	1/1988	Bunnelle et al.	2003/0116284 A1	6/2003	Downs
4,731,066 A	3/1988	Korpman	2003/0118771 A1	6/2003	Downs
4,804,437 A	2/1989	Tirtoprodjo et al.	2004/0194896 A1	10/2004	Steinberger
4,820,446 A	4/1989	Prud'Homme	2004/0219332 A1	11/2004	Dean et al.
4,822,687 A	4/1989	Kessel et al.	2005/0255275 A1	11/2005	Downs et al.
4,844,636 A	7/1989	Paque	2008/0017323 A1	1/2008	Peterson
4,846,924 A	7/1989	Morrison	2011/0059282 A1	3/2011	Downs et al.
4,851,074 A	7/1989	Hiromichi			
4,851,278 A	7/1989	Enanoza	DE 20210691	9/2002	
4,959,008 A	9/1990	Wasulko	EP 0609826	8/1994	
4,961,804 A	10/1990	Aurichio	EP 0619189	10/1994	
4,965,113 A	10/1990	Jones et al.	EP 1233046	8/2002	
4,977,006 A	12/1990	Smith et al.	EP 1445226	9/2004	
4,985,499 A	1/1991	Nishikawa et al.	EP 1541514	6/2005	
5,045,145 A	9/1991	Becker	GB 681096	10/1952	
5,049,434 A	9/1991	Wasulko	GB 780291	7/1957	
5,133,827 A	7/1992	Ratermann	GB 936447	9/1963	
5,147,489 A	9/1992	Scrutton	GB 936448	9/1963	
5,158,818 A	10/1992	Aurichio	GB 978566	12/1964	
5,202,169 A	4/1993	Spendlove	GB 1404925	9/1975	
5,254,206 A	10/1993	Wing	GB 2208825	4/1989	
5,316,613 A	5/1994	Samuelson et al.	GB 2361442	10/2001	
5,344,681 A	9/1994	Calhoun et al.	GB 2397258	7/2004	
5,456,792 A	10/1995	Rodriguez et al.	JP 2011684	1/1990	
5,486,389 A	1/1996	Gerber	JP 10007310	1/1998	
5,489,453 A	2/1996	Friesch	JP 2001018586	1/2001	
5,499,877 A	3/1996	Sakanishi et al.	WO WO92/19447	11/1992	
5,575,097 A	11/1996	Chou et al.	WO WO2006054895	5/2006	
5,575,202 A	11/1996	Pfeiffer			

FOREIGN PATENT DOCUMENTS

DE	20210691	9/2002
EP	0609826	8/1994
EP	0619189	10/1994
EP	1233046	8/2002
EP	1445226	9/2004
EP	1541514	6/2005
GB	681096	10/1952
GB	780291	7/1957
GB	936447	9/1963
GB	936448	9/1963
GB	978566	12/1964
GB	1404925	9/1975
GB	2208825	4/1989
GB	2361442	10/2001
GB	2397258	7/2004
JP	2011684	1/1990
JP	10007310	1/1998
JP	2001018586	1/2001
WO	WO92/19447	11/1992
WO	WO2006054895	5/2006

* cited by examiner

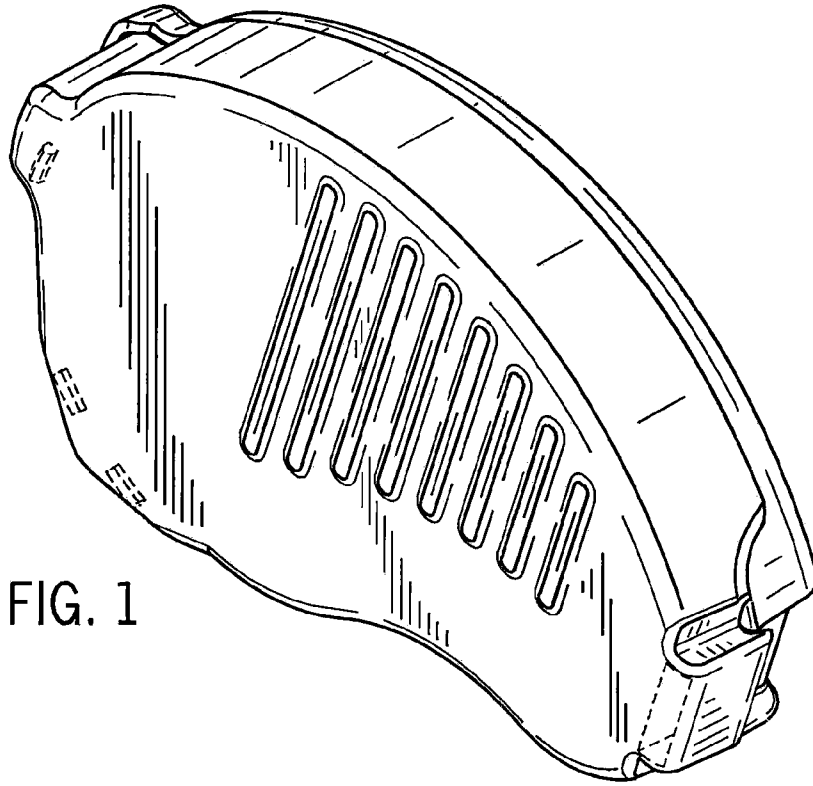

FIG. 1

FIG. 2

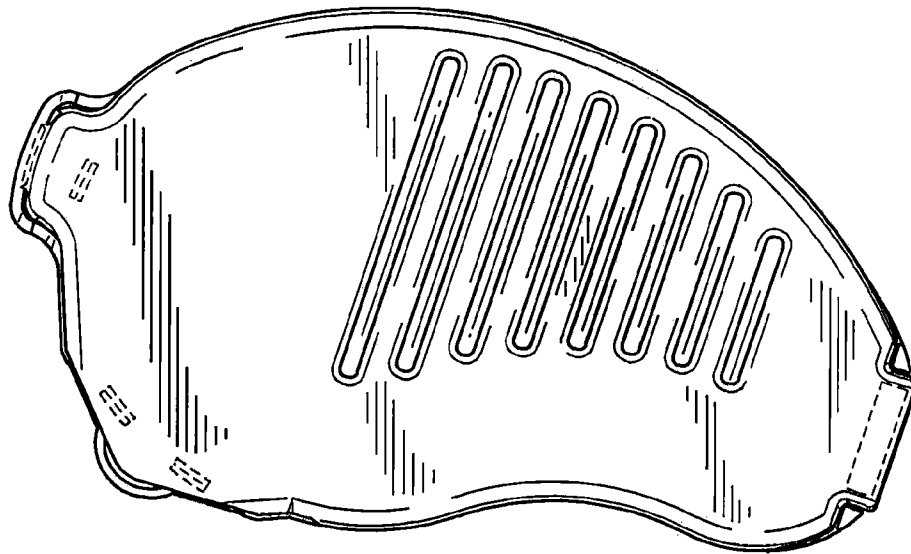

FIG. 3

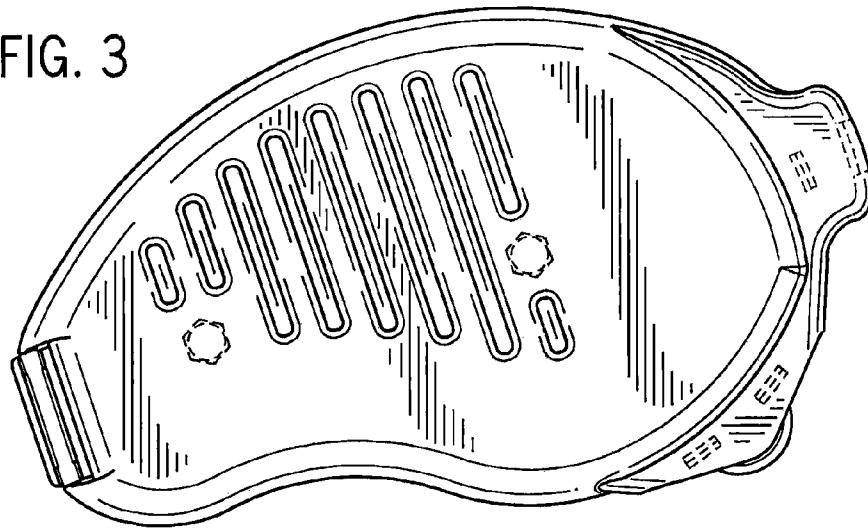

FIG. 4

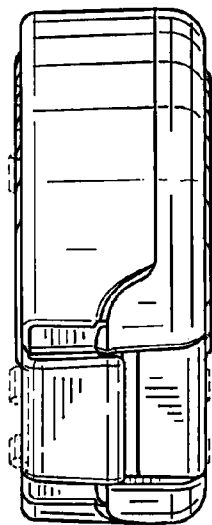

FIG. 5

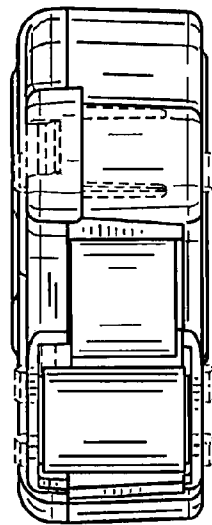

FIG. 6

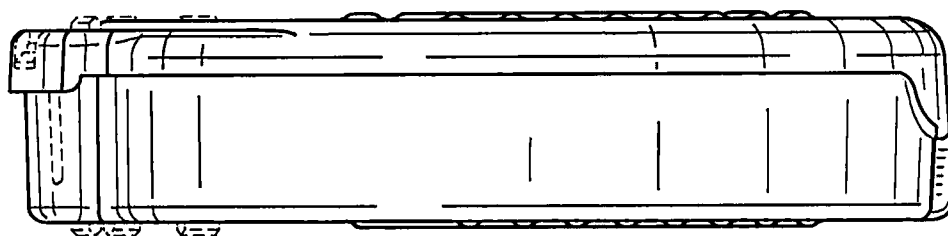
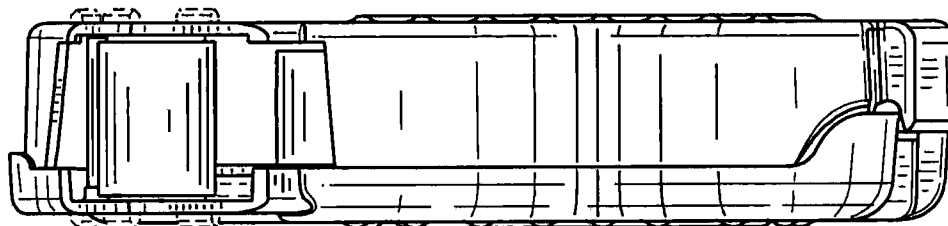

FIG. 7



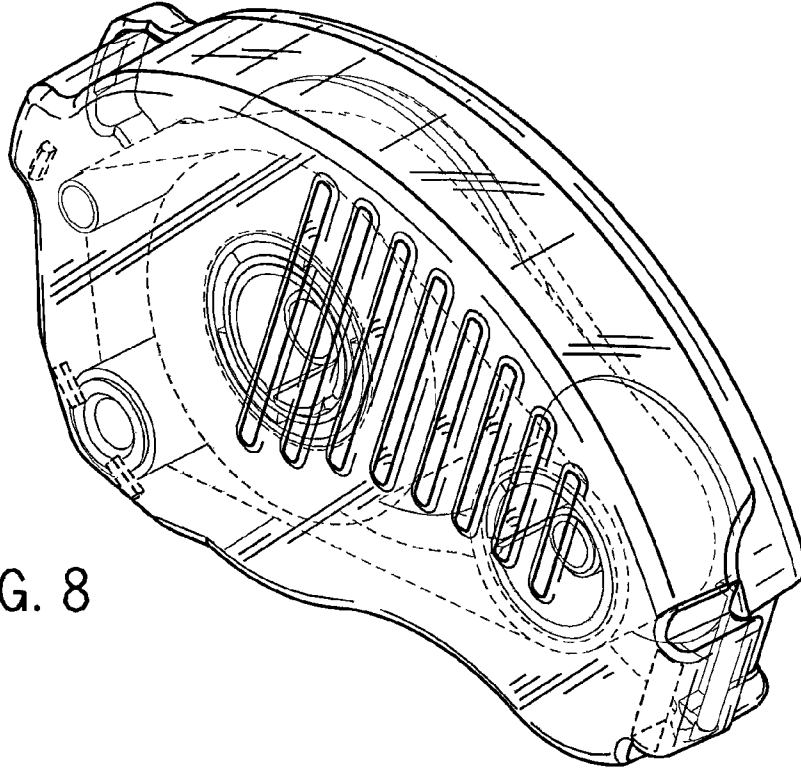

FIG. 8

FIG. 9

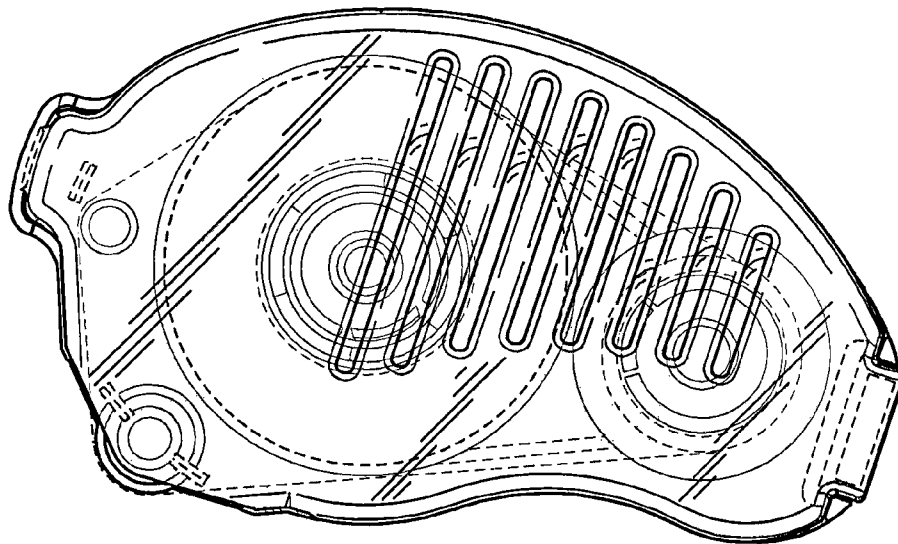

FIG. 10

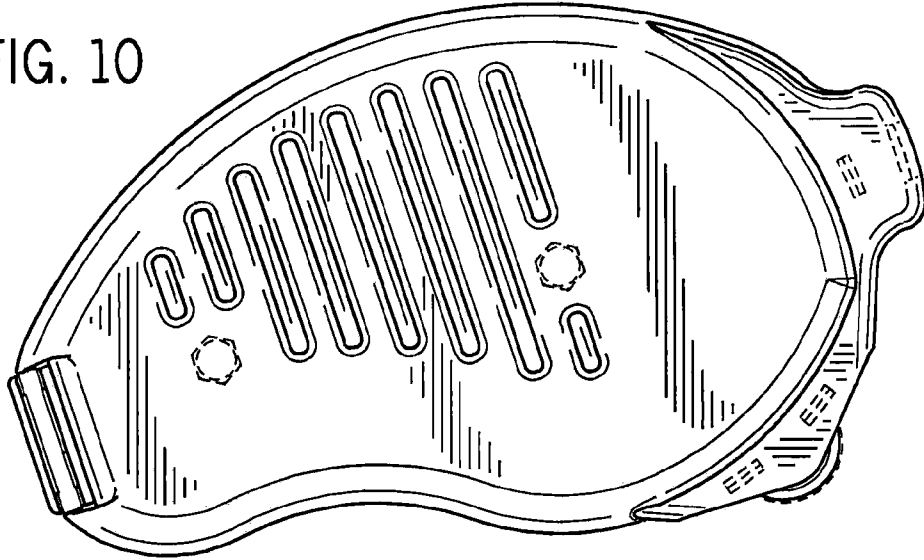

FIG. 11

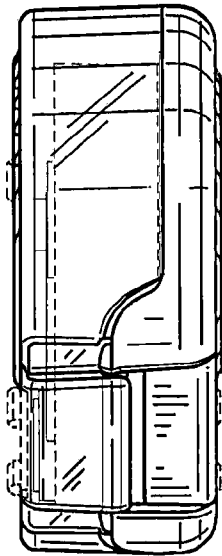

FIG. 12

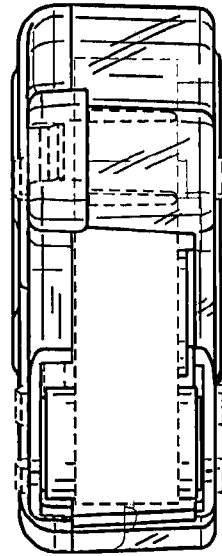

FIG. 13

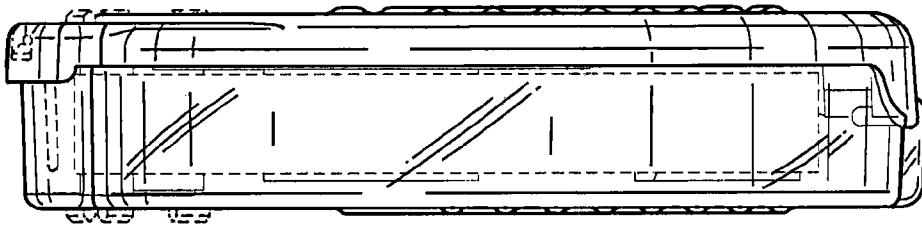
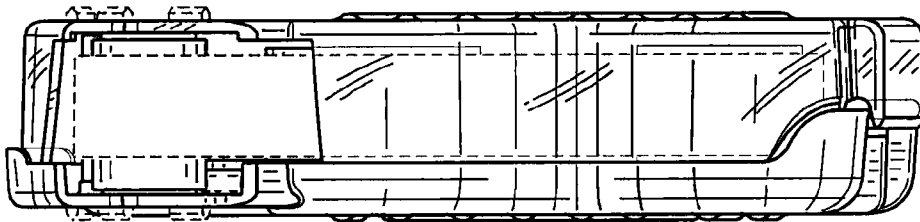

FIG. 14



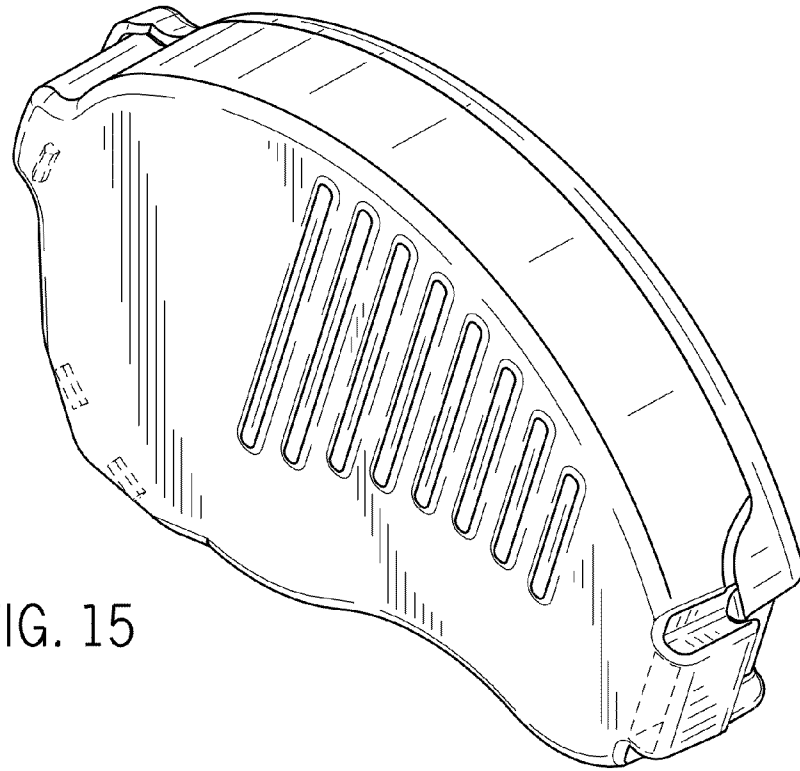
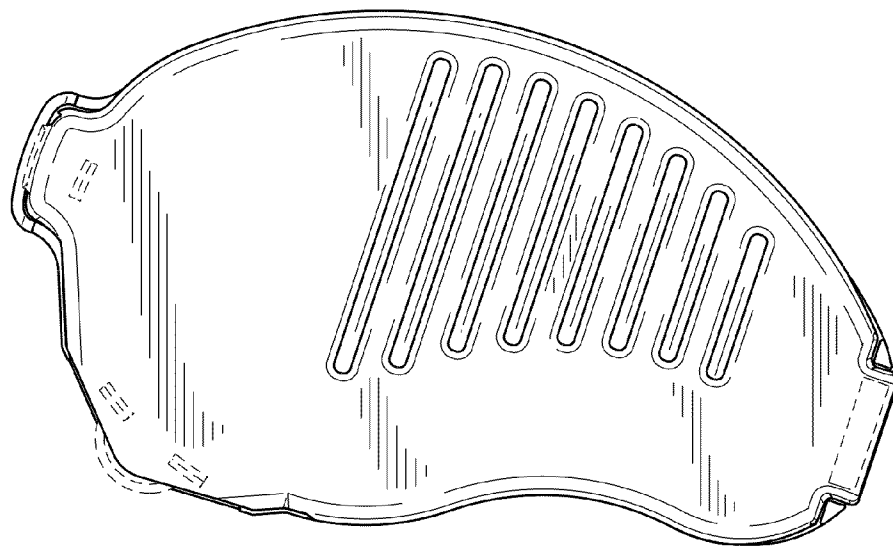

FIG. 15

FIG. 16



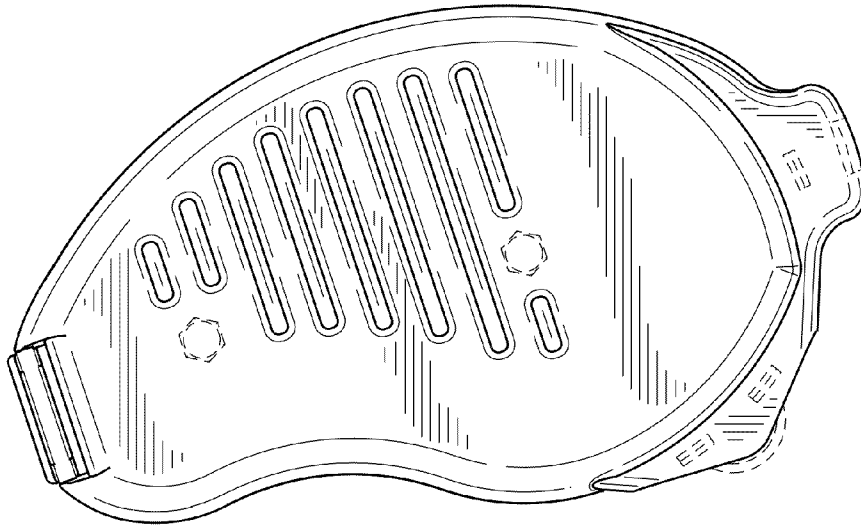

FIG. 17

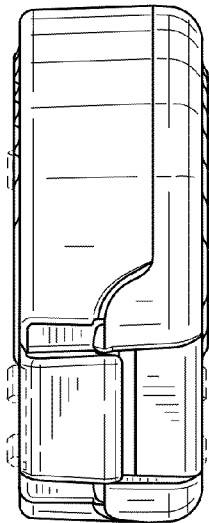

FIG. 18

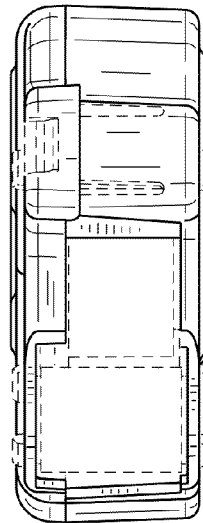

FIG. 19

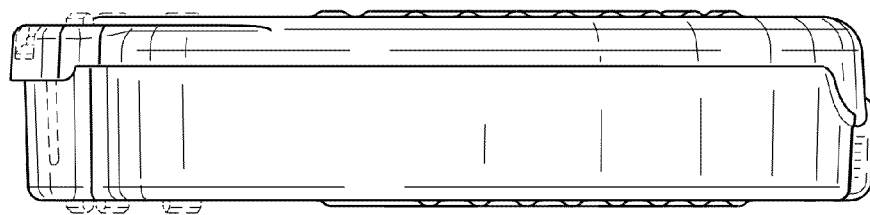

FIG. 20

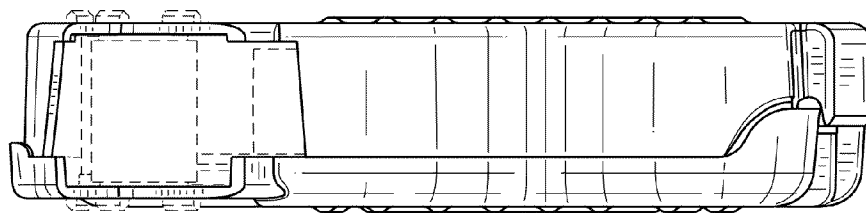

FIG. 21