

(No Model.)

G. R. LEAN.
ELECTRIC SWITCH.

No. 445,957.

Patented Feb. 3, 1891.

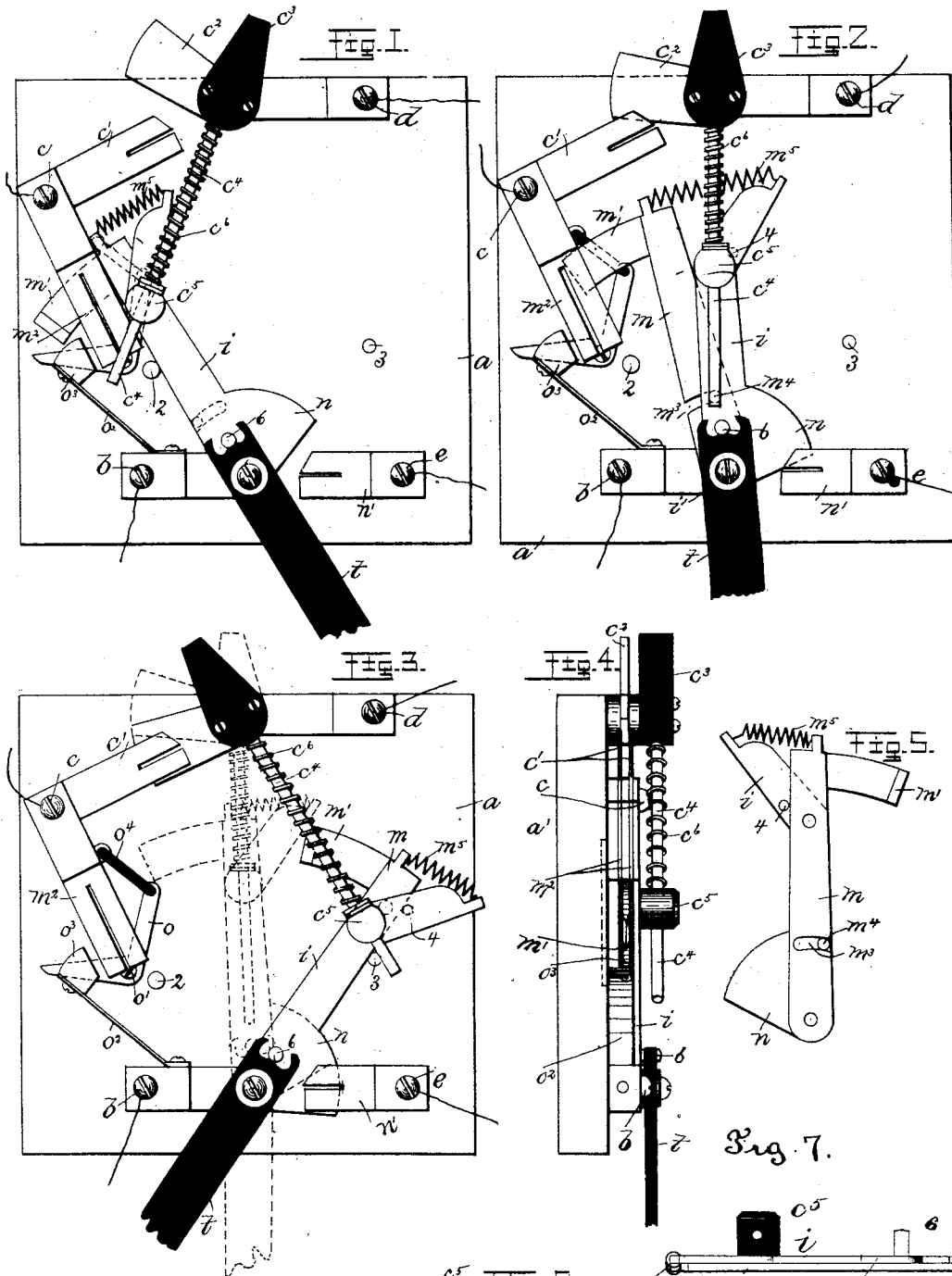

Witnesses.

Geo. C. Huntington
Frederick L. Emery

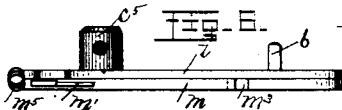

Inventor
George R. Lean,

by Lemby & Gregory

UNITED STATES PATENT OFFICE.

GEORGE R. LEAN, OF BOSTON, MASSACHUSETTS, ASSIGNOR TO THE BERNSTEIN ELECTRIC COMPANY, OF PORTLAND, MAINE.

ELECTRIC SWITCH.

SPECIFICATION forming part of Letters Patent No. 445,957, dated February 3, 1891.

Application filed March 24, 1890. Serial No. 345,125. (No model.)

To all whom it may concern:

Be it known that I, GEORGE R. LEAN, of Boston, county of Suffolk, State of Massachusetts, have invented an Improvement in Electric Switches, of which the following description, in connection with the accompanying drawings, is a specification, like letters and figures on the drawings representing like parts.

This invention has for its object to construct an electric switch especially adapted for switching a loop or branch wire into and out of circuit with a main-line wire, the switch being designed for use in connection with high-tension currents.

The principal feature of this invention is in constructing the parts so that when the loop or branch wire is connected to the main-line wire a closed shunt is formed for said loop or branch wire between the connecting-points, which is thereafter opened, that the entire current may pass through the loop or branch, and when the loop or branch wire is disconnected from the main line said loop or branch will be opened before the main line is closed; and my invention consists in details of construction, as hereinafter pointed out in the claims at the end of the specification.

Figure 1 shows in front elevation an electric switch embodying this invention, the parts being in position to disconnect the loop or branch from the main-line wire; Fig. 2, a similar view to Fig. 1, the parts being in position to connect the loop or branch with the main-line wire, but at the same time maintaining a closed shunt for the loop or branch; Fig. 3, a similar view to Fig. 1, the parts being in position to connect the loop or branch with the main-line wire and to open the shunt so that the said loop or branch is included directly in the main-line circuit; Fig. 4, a side view of the switch shown in Fig. 1; Fig. 5, a rear side view of one of the members to be referred to; Fig. 6, an edge view of the parts shown in Fig. 5, and Fig. 7 an edge view of one of the parts to be referred to.

The base-plate *a* is of any suitable shape and construction to sustain the working parts. Arranged on the base-plate *a* are four blocks

or posts *b c d e*, to which the main-line and the loop or branch wires are attached—as, for instance, the main-line wires being attached to the blocks *b c* and the loop or branch wires to the blocks *d e*. One or more contact-pens, as *c'*, two being herein shown, are attached to the main-line blocks *c*, and a contact-plate *c²* is pivotally connected to a plate electrically connected with the branch-line block *d*, said plate being secured to a block *c³* of insulating material. A rod *c⁴* is also fixed to the block *c³*, which passes through a hole in a stud *c⁵*, loosely connected with or pivoted to an arm *i*. The hole or passage in the stud *c⁵*, through which the rod passes, is lined with insulating material, or the stud itself may be made of insulating material. A spiral spring *c⁶* encircles the rod *c⁴*, bearing at one end against the block *c³* and at the other end against the stud *c⁵*. The arm *i* is pivoted at *i'* directly opposite the pivot of the block *c³*, and the spring *c⁶* tends to hold the said arm *i* against one or the other fixed pin 2 3 on the base-plate, said spring being compressed when the arm and rod are brought into alignment.

Switches of this kind must be quick-acting, and the spring *c⁶* and its connection with the arm *i* is for this purpose constituting what is commonly called a "jump-switch."

A contact-plate *n* is secured to or formed integral with the arm *i*, which when the arm is moved from its position shown in Fig. 1 toward the right contacts with one or more contact-pens *n'*, two being herein shown. These pens *n'* are electrically connected with the branch-line block *e*.

With the parts thus far described, by moving the arm *i* sufficiently to enable the contact-plate *n* to contact with the pens *n'* the contact-plate *c²* will contact with the pens *c'*, as shown in Fig. 2. The branch-line blocks *d e* will at such time be connected with the main-line blocks *b c* electrically. An arm *m* is also pivoted at *i'* in a plane parallel with the arm *i*, said arm *m* having a contact-plate *m'*, which engages contact-pens *m²*, two being herein shown. These pens *m²* are connected to the main-line block *c*. The arm *m* has a slot *m³*, in which slot a pin or stud *m⁴*, fixed

to the arm *i*, moves. The arms *m* and *i* are connected, preferably at their outer ends, by a spiral spring *m*⁵.

With the parts in the position shown in Fig. 1 the contact-plate *m*' is in engagement with the contact-pens *m*², and the loop or branch wire is disconnected, so that the main-line current passes through the main-line block or post *b*, arm *m*, contact-plate *m*', contact-pens *m*², and main-line block or post *c*. As the arm *i* is moved toward the right into the position shown in Fig. 2, the pin *m*⁴ follows in the slot *m*³, but does not engage with the arm *m* until the arm *i* and rod *c*⁴ are in alignment. The spring *m*⁵ during such movement of the arm *i* acts upon and causes the arm *m* to follow the arm *i*, but at a less rate of speed, it being understood that the spring *m*⁵ is not strong enough to pull the arm *m* with the arm *i*. When the parts arrive in this position, Fig. 2, it will be seen that the loop or branch-line blocks *d e* are connected with the main-line wire, but at the same time the contact-plate *m*' has not left the contact-pens *m*², and hence a shunt is maintained for the loop or branch wire. As soon, however, as the arm *i* passes further to the right and immediately beyond true alignment with the rod *c*⁴, the spring *c*⁶ will force the arm *i* against the fixed pin 3, as shown in Fig. 3, and the pin *m*⁴ will move the arm *m* simultaneously with the arm *i*, the spring *m*⁵ exerting its force to bring the arms together.

It will be seen that the shunt for the loop or branch is broken after the said loop or branch has been connected with the main-line wire.

To restore the parts to their normal position, or to the position illustrated in Fig. 1, the arm *i* is moved in the opposite direction, compressing the spring *c*⁶, as aforesaid, and a pin 4 on the arm *i* striking the side of the arm *m* moves the said arm *m* with it. On the return of the parts, when the arm *m* and rod *i* are in alignment and the contact-plates *c*² and *n* just leaving their respective contact-pens, the contact-plate *m*' will be in position to immediately thereafter engage the contact-pens *m*², thereby closing the main line at *m*' *m*² immediately after the contact-plates *c*² and *n* have left their respective contact-pens *c*' *n*'. Thus on the return of the parts to disconnect the loop from the main line the main line will be closed after the said loop has been electrically disconnected. The contact pens and plates constitute switches between the respective posts for making and breaking the electric connection. A bell-crank lever *o* is pivoted at *o*', one arm of said lever being pressed upon by a flat spring *o*², carrying a contact-plate *o*³, and the other arm being held by a link *o*⁴ of fusible material.

If by any accident an arc should be formed between the contact-pens *m*² and the contact-plate *m*' and the link *o*⁴ should fuse, the contact-plate *o*³ will be allowed to engage the contact-pens *m*². The flat spring *o*² is connected

with the block *b*, so that in the event of the contact-plate *o*³ engaging the contact-pens *m*² the main-line circuit will be closed.

I do not desire to limit myself to the precise construction herein shown of connecting the loop or branch circuit with the main-line wire and thereafter opening the shunt to permit the entire current to pass over said loop or branch wire, as it may be constructed in many different ways still coming within the spirit and scope of this invention; nor do I desire to limit my invention to the particular construction of switch herein shown for connecting a loop or branch wire to a main line and thereafter opening the main line to allow the current to pass over said loop or branch and for disconnecting said loop or branch wire from the main line and thereafter closing said main line.

An operating-lever *t* is arranged on the pivoted pin *i*', which engages a pin 6 on the arm *i* to move it in a manner similar to ordinary jump-switches.

I claim—

1. In an electric switch, two main-line blocks and a switch between them, two branch-line blocks and a switch between each branch-line block and the main-line blocks, the movable members of the branch-line switches operating in advance of the movable member of the main-line switch at every movement thereof, substantially as described.

2. In an electric switch, two main-line blocks and a switch between them for making and breaking an electric connection, combined with a branch-line block, as *e*, and a switch between it and one of the main-line blocks, the movable members of said switches being elastically connected together, and means for moving said members, substantially as described.

3. In an electric switch, two main-line blocks and a switch between them to make and break an electric connection, combined with two branch-line blocks, and a switch between each branch-line block and the main-line blocks to make and break an electric connection, and two arms carrying the movable members of said switches moving independently in one direction, but simultaneously in the other direction, substantially as described.

4. In an electric switch, two main-line blocks and a switch between them, and an arm, as *m*, carrying the movable member thereof, combined with two branch-line blocks, and a switch between each of said blocks and the main-line blocks, and an arm, as *i*, carrying the movable members of one of said last-named switches, one of said arms engaging and moving the other when moved in one direction, but moving independently when moving in the opposite direction, substantially as described.

5. In an electric switch, two main-line blocks, a contact-pen, and contact-plate between them to make and break an electric connection, combined with two branch-line blocks,

and a contact-pen and contact-plate between each of said branch-line blocks and the main-line blocks to make and break electric connection between each of said branch-line blocks and the main-line blocks, and means for moving said contact-plates, substantially as described.

6. In an electric switch, two main-line blocks and a switch between them, two branch-line blocks, and a switch between each branch-line block and the main-line blocks, a spring for moving the movable member of the main-line switch to make and break electric connection, and a hand-lever for moving the movable members of the branch-line switches and extending the operating-spring of the main-line switch, substantially as described.

7. In an electric switch, main-line blocks and a contact-pen between them, a contact-plate, and arm carrying it, combined with branch-line blocks, contact-pens between said blocks and the main-line blocks, contact-plates c^2 and n , the arm i and rod c^1 , connected together, the spring c^b , and the loosely-con-

nected operating-lever l , substantially as described.

8. In an electric switch, main-line blocks and a contact-pen between them, a contact-plate, and arm m carrying it, combined with branch-line blocks, contact-pens, and contact-plates, the arm i , having a pin m^1 , and a pin 1 to engage and move the said arm m , substantially as described.

9. In an electric switch, two main-line blocks and a switch between them, combined with a branch-line block, as e , and a switch between it and one of the main-line blocks, the movable member of the branch-line switch operating in advance of the movable member of the main-line switch at every movement thereof, substantially as described.

In testimony whereof I have signed my name to this specification in the presence of two subscribing witnesses.

GEORGE R. LEAN.

Witnesses:

BERNICE J. NOYES,
EMMA J. BENNETT.