



(19) **United States**
 (12) **Reissued Patent**
Lang et al.

(10) **Patent Number:** **US RE46,829 E**
 (45) **Date of Reissued Patent:** **May 8, 2018**

(54) **METHOD FOR SEPARATING HIGH MOLECULAR WEIGHT GASES FROM A COMBUSTION SOURCE**

(71) Applicant: **GAS SEPARATION TECHNOLOGIES, INC.**, Seattle, WA (US)

(72) Inventors: **Jerry Lang**, Lindale, TX (US); **David Scott**, Rockwall, TX (US)

(73) Assignee: **GAS SEPARATION TECHNOLOGIES, INC.**, Seattle, WA (US)

(56) **References Cited**

U.S. PATENT DOCUMENTS

3,199,269 A * 8/1965 Oehrich et al. 96/372
 3,915,673 A 10/1975 Tamai et al.
 (Continued)

FOREIGN PATENT DOCUMENTS

EP 0 540 743 A1 5/1993
 EP 0540743 5/1993
 (Continued)

OTHER PUBLICATIONS

PCT International Search Report and Written Opinion of PCT/US2011/063848, dated Jul. 2, 2012.
 (Continued)

(21) Appl. No.: **15/016,608**
 (22) Filed: **Feb. 5, 2016**

Related U.S. Patent Documents

Reissue of:

(64) Patent No.: **8,652,234**
 Issued: **Feb. 18, 2014**
 Appl. No.: **14/086,049**
 Filed: **Nov. 21, 2013**

Primary Examiner — Krisanne Jastrzab
 (74) *Attorney, Agent, or Firm* — Christopher A. Wiklof; Nicholas S. Bromer; Launchpad IP, Inc.

U.S. Applications:

(62) Division of application No. 13/314,110, filed on Dec. 7, 2011, now Pat. No. 8,657,919.
 (Continued)

(57) **ABSTRACT**

High molecular weight (HMW) gases are separated from an exhaust gas of a combustion source using a blower and an interior vent within the exhaust stack. The interior vent includes a vent wall having a top portion attached to the interior surface of the exhaust stack along the entire inner perimeter of the exhaust stack and a lower portion that extends downward into the exhaust stack to form an annular space or gap between the vent wall and the interior surface of the exhaust stack, and at least one opening in the interior surface of the exhaust stack between the top and bottom portions of the vent wall. The blower creates a tangential flow of the exhaust gas with sufficient centrifugal force to concentrate substantially all of the HMW gases along the inner surface of the exhaust stack. A transfer pipe removes the HMW gases from the interior vent.

(51) **Int. Cl.**
B01D 53/24 (2006.01)
C01D 7/07 (2006.01)
B01D 53/62 (2006.01)

(52) **U.S. Cl.**
 CPC **C01D 7/07** (2013.01); **B01D 53/24** (2013.01); **B01D 53/62** (2013.01);
 (Continued)

(58) **Field of Classification Search**
 CPC .. B01D 53/24; B01D 2251/304; B01D 53/62; B01D 2258/0283; B01D 2257/504; C01D 7/07; Y02P 20/152; Y02C 10/04
 See application file for complete search history.

18 Claims, 4 Drawing Sheets

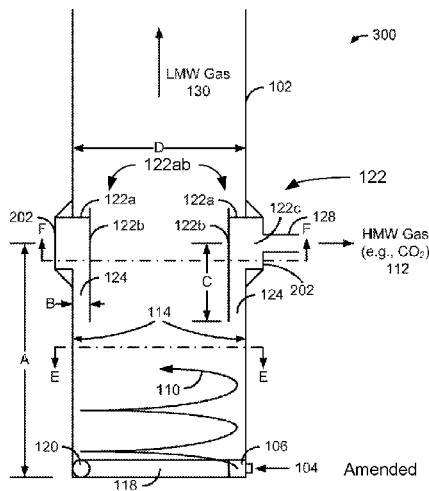

Amended

US RE46,829 E

Page 2

Related U.S. Application Data

(60) Provisional application No. 61/420,751, filed on Dec. 7, 2010.

(52) U.S. Cl.

CPC .. *B01D 2251/304* (2013.01); *B01D 2257/504* (2013.01); *B01D 2258/0283* (2013.01); *Y02C 10/04* (2013.01); *Y02P 20/152* (2015.11)

(56)

References Cited

U.S. PATENT DOCUMENTS

4,014,981	A	3/1977	Wainer	
4,557,912	A	12/1985	Maguire	
4,710,126	A	12/1987	Areaux et al.	
4,859,347	A *	8/1989	Simon	B01D 17/0217 209/723
5,092,912	A	3/1992	Korman	
5,405,420	A *	4/1995	Yang	96/372
5,453,196	A *	9/1995	Tuszko	B01D 45/12 209/715
5,491,976	A	2/1996	Rock et al.	
5,567,390	A	10/1996	Cleary	
5,964,985	A	10/1999	Wootten	
6,648,949	B1	11/2003	Der et al.	
7,159,723	B2	1/2007	Hilpert et al.	
7,857,889	B2	12/2010	Morf	
8,357,232	B1	1/2013	Morrison	
8,702,848	B2	4/2014	Kulprathipanja et al.	

8,795,405	B1	8/2014	Aident et al.	
9,108,148	B2	8/2015	Hassan et al.	
2002/0068031	A1	6/2002	Confuorto et al.	
2002/0189443	A1	12/2002	McGuire	
2003/0221558	A1	12/2003	Lister et al.	
2006/0037918	A1	2/2006	Spani	
2008/0169576	A1	7/2008	Kojima	
2009/0068090	A1	3/2009	Cherry	
2009/0301296	A1	12/2009	Hoijtink et al.	
2010/0037771	A1*	2/2010	Christensen	B01D 53/24 95/35
2010/0236242	A1	9/2010	Farsad et al.	
2010/0313751	A1	12/2010	Hassan et al.	
2011/0167866	A1	7/2011	Evans-Beauchamp	
2012/0141352	A1	6/2012	Lang et al.	
2012/0192714	A1	8/2012	Kulprathipanja et al.	
2013/0025455	A1	1/2013	Morrison	

FOREIGN PATENT DOCUMENTS

WO	2012/078821	A2	6/2012
WO	WO 2012/078821		6/2012

OTHER PUBLICATIONS

International Search Report for PCT/US2011/063848, published Sep. 20, 2012, 4 pages.

Written Opinion for PCT/US2011/063848, dated Jul. 2, 2012, 8 pages.

* cited by examiner

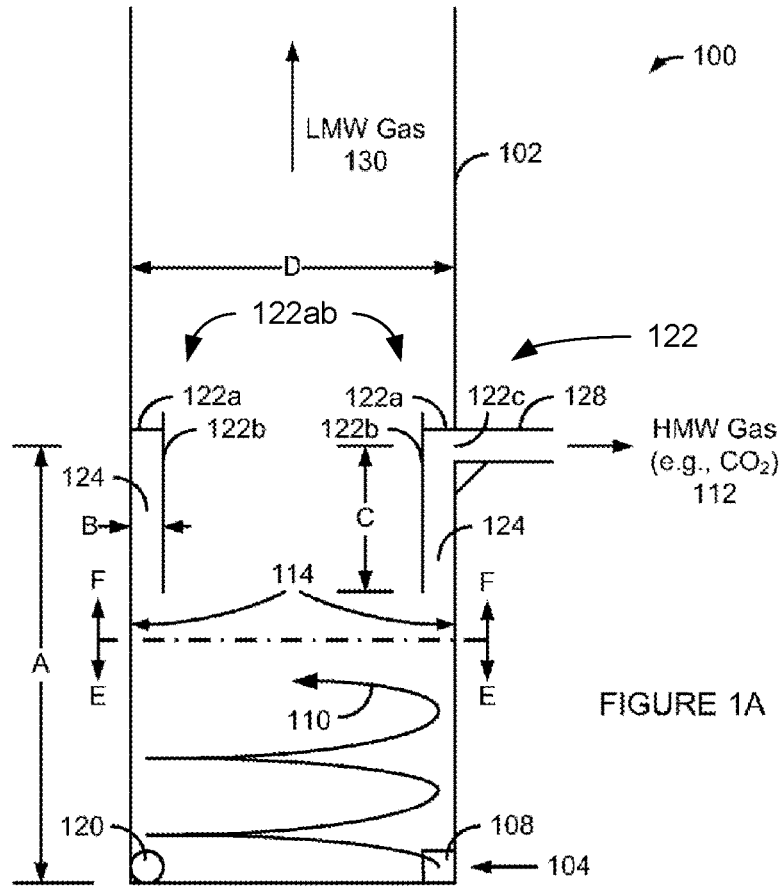

FIGURE 1A

Amended

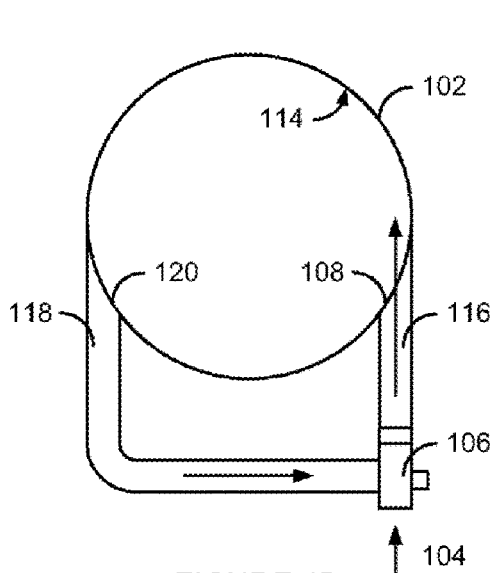

FIGURE 1B
CROSS SECTION E-E

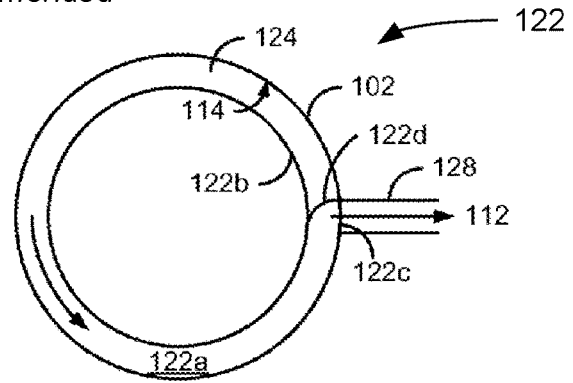

FIGURE 1C
CROSS SECTION F-F

Amended

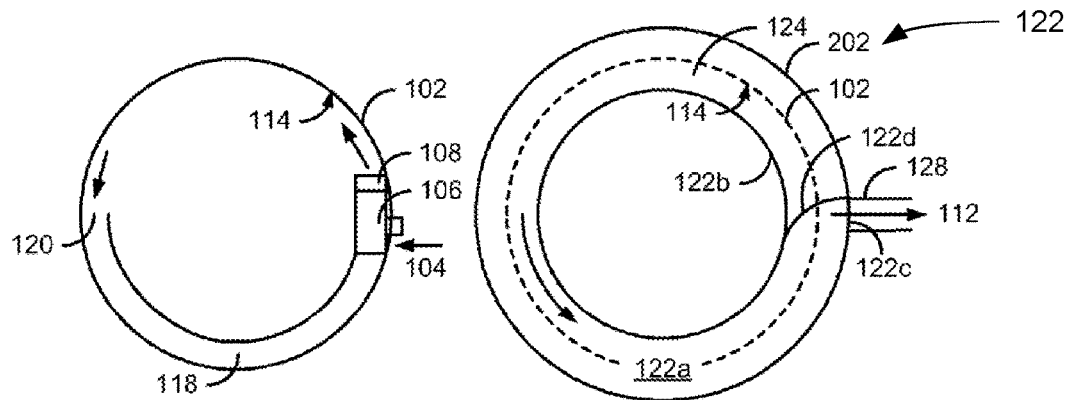
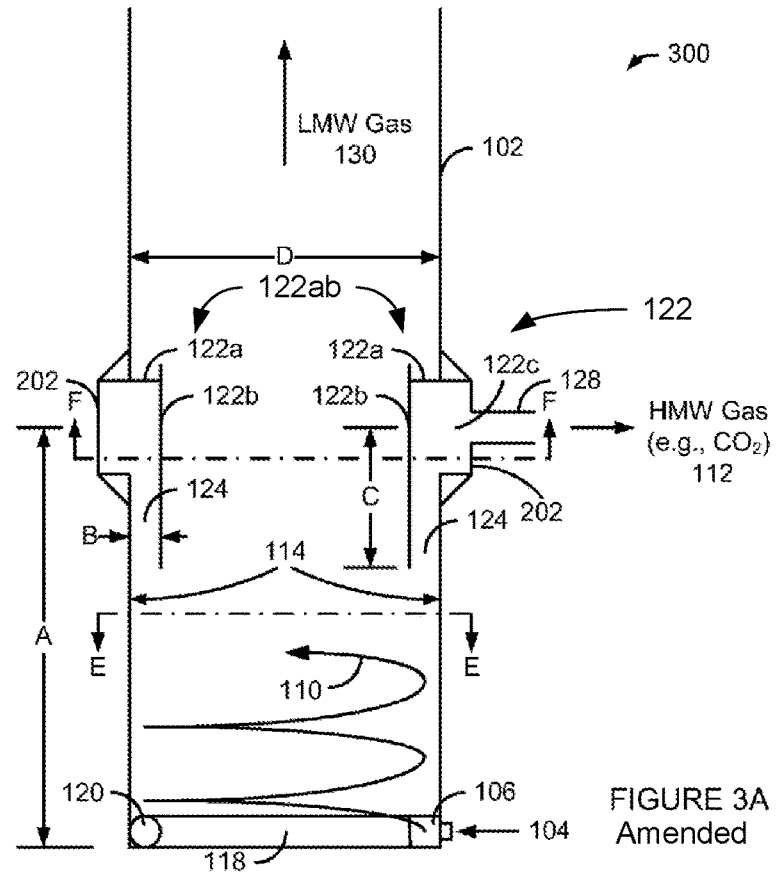

FIGURE 3B
CROSS SECTION E-E

FIGURE 3C
CROSS SECTION F-F

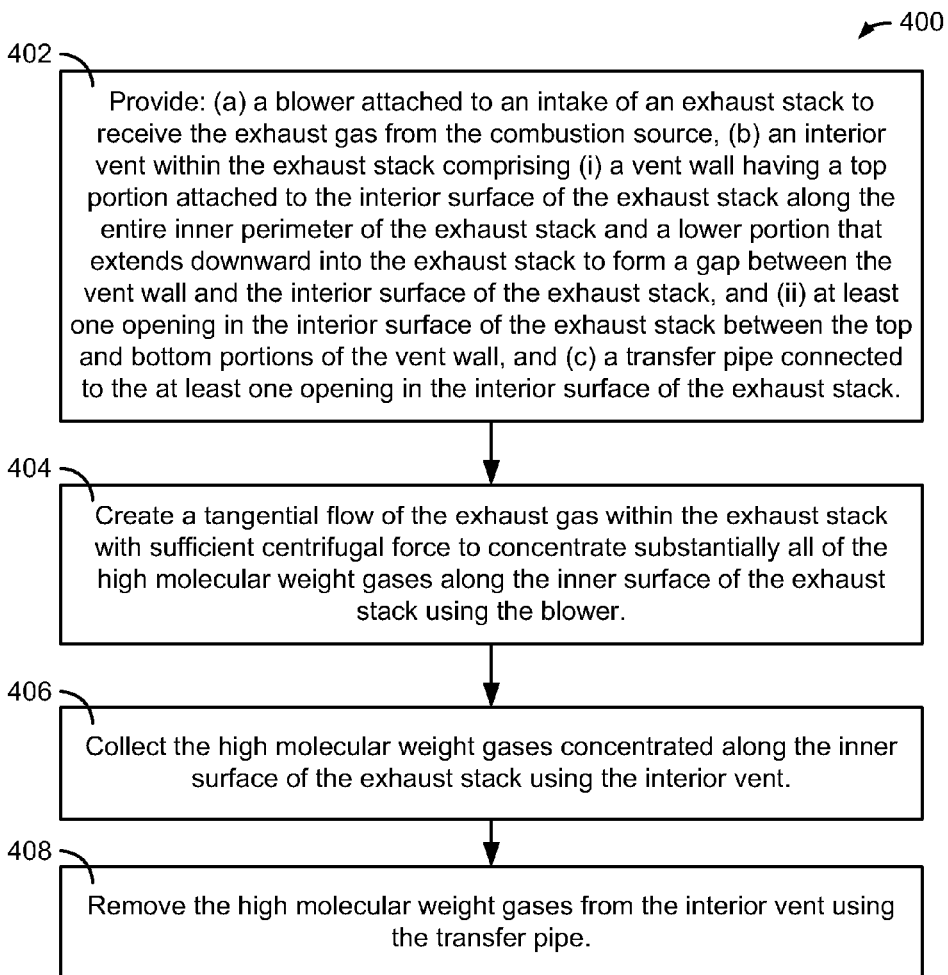

FIGURE 4

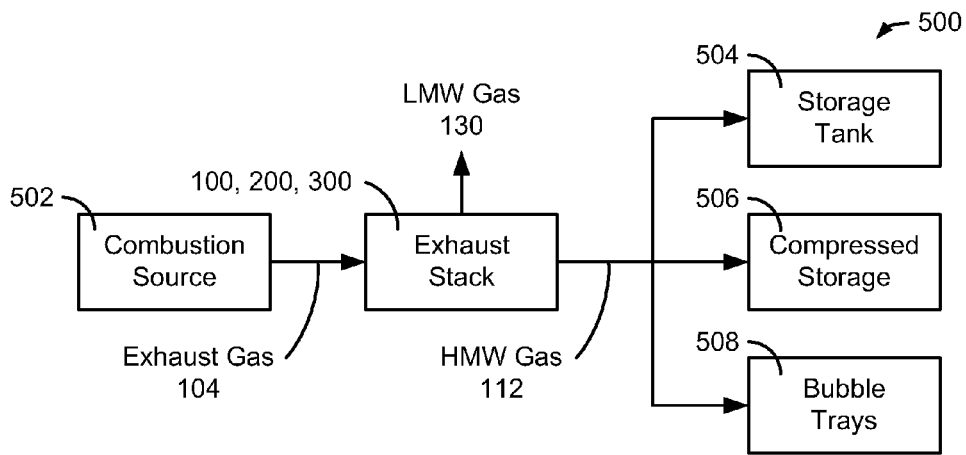

FIGURE 5

1

**METHOD FOR SEPARATING HIGH
MOLECULAR WEIGHT GASES FROM A
COMBUSTION SOURCE**

Matter enclosed in heavy brackets [] appears in the original patent but forms no part of this reissue specification; matter printed in italics indicates the additions made by reissue; a claim printed with strikethrough indicates that the claim was canceled, disclaimed, or held invalid by a prior post-patent action or proceeding.

CROSS-REFERENCE TO RELATED
APPLICATIONS

This application is a divisional of U.S. patent application Ser. No. 13/314,110, filed Dec. 7, 2011, which claims priority to U.S. Provisional Application Ser. No. 61/420,751, filed Dec. 7, 2010, the entire contents of which are incorporated herein by reference.

FIELD OF THE INVENTION

The present invention relates generally to the field of separation and sequestration of combustion exhaust gases.

BACKGROUND OF THE INVENTION

Combustion systems have come under increased scrutiny for toxic emissions which are a by-product of the combustion process. Depending upon the extent of the combustion, carbon monoxide and NO_x may be emitted at unacceptable levels. Carbon monoxide levels are normally controlled through complete combustion resulting in carbon dioxide. In fact, in years past, carbon dioxide was measured to determine the efficiency of the process. Traditionally, NO_x and other VOC emissions have been either controlled by cleaner fuels or techniques that reduce formation. Recently, because of the push for alternative and renewable fuels, carbon dioxide being the only component here-to-fore not regulated has come under increased scrutiny (green house gases, carbon footprints and global warming).

The problem is, burning fossil fuels makes carbon dioxide, and burning fossil fuels more efficiently makes even more carbon dioxide. NO_x and SO_x along with other pollutants, which comprise only parts per million in the resulting emissions, are controlled by many effective methods; but there few effective methods of controlling CO₂ emissions.

Since CO₂ comprises from 10 to 15% of the exhaust or flue gas by volume, it is impractical to treat it without separating it from the remaining gases. Several systems have been developed to reduce the CO₂, and in some cases to concentrate the gas. Increasing the amount of hydrogen in the fuel will reduce the fraction of CO₂ in the flue gas, since hydrogen combustion does not produce CO₂. If the exhaust or flue gas is recirculated and the incoming fuel is mixed with pure O₂ the nitrogen in the air is eliminated. And, with enough recycling of the exhaust or flue gas, the CO₂ is concentrated to higher levels. After concentration, there are accepted methods of either using or treating the CO₂. The burning of the hydrogen simply reduces the CO₂. These known methods are quite inflexible and require reconfiguring the combustion equipment. In many cases, very flexible control algorithms will need to be employed to adjust the various fuel-air curves needed for the ever changing fuel

2

compositions. The production or purchase of the hydrogen or oxygen needed in these processes also tend to make them impractical.

SUMMARY OF THE INVENTION

The present invention provides a system and method for separating high molecular weight gases, such as CO₂, from any combustion source. More specifically, the present invention imparts centrifugal force on the exhaust or flue gas by spinning the exhaust or flue gas with enough velocity to remove the heavy components, such as CO₂, to the outside diameter of the stack and removing it thru an annular space or gap formed by an interior vent. The spin needed for the centrifugal action may be imparted by using a blower to remove the gas tangentially from one side of the stack and blowing it tangentially back into the stack on the other side. The use of a stationary tubulator, or spin vanes, or actual in-stack centrifuge may be necessary in addition to the blower. Note that the velocity of the system may be varied to accommodate various fuels and flue gas mixtures. Moreover, the system may be fitted to stacks of virtually any size or flow. As a result, the present invention provides a simple process to take care of the hardest and most expensive step in controlling CO₂. Many treatment options are available after separation.

One embodiment of the present invention provides a method for separating high molecular weight gases from an exhaust gas of a combustion source by providing (a) a blower attached to an intake of an exhaust stack to receive the exhaust gas from the combustion source, (b) an interior vent within the exhaust stack comprising (i) a vent wall having a top portion attached to the interior surface of the exhaust stack along the entire inner perimeter of the exhaust stack and a lower portion that extends downward into the exhaust stack to form an annular space or gap between the vent wall and the interior surface of the exhaust stack, and (ii) at least one opening in the interior surface of the exhaust stack between the top and bottom portions of the vent wall, and (c) a transfer pipe connected to the at least one opening in the interior surface of the exhaust stack. A tangential flow of the exhaust gas is created within the exhaust stack using the blower, wherein the blower imparts sufficient centrifugal force on the exhaust gas to concentrate substantially all of the high molecular weight gases along the inner surface of the exhaust stack. The high molecular weight gases concentrated along the inner surface of the exhaust stack are collected using the interior vent. The high molecular weight gases are removed from the interior vent using the transfer pipe.

In addition, the present invention provides a system for separating high molecular weight gases in an exhaust stack from an exhaust gas of a combustion source using a blower, an interior vent and a transfer pipe. The blower is attached to an intake of the exhaust stack to receive the exhaust gas from the combustion source and create a tangential flow of the exhaust gas within the exhaust stack. The blower imparts sufficient centrifugal force on the exhaust gas to concentrate the high molecular weight gases along the inner surface of the exhaust stack. The interior vent is disposed within the exhaust stack and collects the high molecular weight gases concentrated along the inner surface of the exhaust stack. The interior vent includes (i) a vent wall having a top portion attached to the interior surface of the exhaust stack along the entire inner perimeter of the exhaust stack and a lower portion that extends downward into the exhaust stack to form an annular space or gap between the vent wall and the

3

interior surface of the exhaust stack, and (ii) at least one opening in the interior surface of the exhaust stack between the top and bottom portions of the vent wall. The transfer pipe is connected to the at least one opening in the interior surface of the exhaust stack to remove the high molecular weight gases from the interior vent.

Moreover, the present invention provides a system for separating high molecular weight gases from an exhaust gas of a combustion source using an exhaust stack, a blower, an interior vent and a transfer pipe. The blower is attached to an intake of the exhaust stack to receive the exhaust gas from the combustion source and create a tangential flow of the exhaust gas within the exhaust stack. The blower imparts sufficient centrifugal force on the exhaust gas to concentrate the high molecular weight gases along the inner surface of the exhaust stack. The interior vent is disposed within the exhaust stack and collects the high molecular weight gases concentrated along the inner surface of the exhaust stack. The interior vent includes (i) a vent wall having a top portion attached to the interior surface of the exhaust stack along the entire inner perimeter of the exhaust stack and a lower portion that extends downward into the exhaust stack to form an annular space or gap between the vent wall and the interior surface of the exhaust stack, and (ii) at least one opening in the interior surface of the exhaust stack between the top and bottom portions of the vent wall. The transfer pipe is connected to the at least one opening in the interior surface of the exhaust stack to remove the high molecular weight gases from the interior vent. The high molecular weight gases have a molecular weight greater than 35 and at least 85% of the high molecular weight gases are concentrated along the inner surface of the exhaust stack. The annular space or gap has an area of approximately 10% of a cross-sectional area of the exhaust stack. The at least one opening is positioned at a height above the bottom of the exhaust stack approximately equal to three diameters of the exhaust stack. The blower causes the exhaust gases to spin around the exhaust stack at least five times within a height approximately equal to one diameter of the exhaust stack.

The present invention is described in detail below with reference to the accompanying drawings which are not to scale.

BRIEF DESCRIPTION OF THE DRAWINGS

The above and further advantages of the invention may be better understood by referring to the following description in conjunction with the accompanying drawings, in which:

FIGS. 1A, 1B and 1C are a cross sectional side view (FIG. 1A), a cross-sectional top view at cross section E-E (FIG. 1B), and a cross-sectional bottom view at cross section F-F (FIG. 1C) of a system for separating high molecular weight (HMW) gases in an exhaust stack in accordance with one embodiment of the present invention;

FIGS. 2A, 2B and 2C are a cross sectional side view (FIG. 2A), a cross-sectional top view at cross section E-E (FIG. 2B), and a cross-sectional bottom view at cross section F-F (FIG. 2C) of a system for separating high molecular weight (HMW) gases in an exhaust stack in accordance with another embodiment of the present invention;

FIGS. 3A, 3B and 3C are a cross sectional side view (FIG. 3A), a cross-sectional top view at cross section E-E (FIG. 3B), and a cross-sectional bottom view at cross section F-F (FIG. 3C) of a system for separating high molecular weight (HMW) gases in an exhaust stack in accordance with one embodiment of the present invention;

4

FIG. 4 is a flow chart of a method for separating high molecular weight (HMW) gases from an exhaust gas in accordance with one embodiment of the present invention; and

FIG. 5 is a block diagram of a system incorporating the embodiments of the present invention.

DETAILED DESCRIPTION OF THE INVENTION

While the making and using of various embodiments of the present invention are discussed in detail below, it should be appreciated that the present invention provides many applicable inventive concepts that can be embodied in a wide variety of specific contexts. The specific embodiments discussed herein are merely illustrative of specific ways to make and use the invention and do not delimit the scope of the invention.

The present invention provides a system and method for separating high molecular weight gases, such as CO₂, from any combustion source. More specifically, the present invention imparts centrifugal force on the exhaust or flue gas by spinning the exhaust or flue gas with enough velocity to remove the heavy components, such as CO₂, to the outside diameter of the stack and removing it thru an annular space or gap formed by an interior vent. The spin needed for the centrifugal action may be imparted by using a blower to remove the gas tangentially from one side of the stack and blowing it tangentially back into the stack on the other side. The use of a stationary tubulator, or spin vanes, or actual in-stack centrifuge may be necessary in addition to the blower. Note that the velocity of the system may be varied to accommodate various fuels and flue gas mixtures. Moreover, the system may be fitted to stacks of virtually any size or flow. As a result, the present invention provides a simple process to take care of the hardest and most expensive step in controlling CO₂. Many treatment options are available after separation.

The typical constituent parts of exhaust or flue gas (used interchangeably) are as follows: the molecular weight of CO₂ is 44 and it comprises 10-15% of flue gases, the molecular weight of N₂ is 28 and it comprises approximately 78% of flue gases, the molecular weight of O₂ is 32 and it comprises approximately 3% of flue gases, the molecular weight of H₂O is 18 and it comprises approximately 10-15% of flue gases, and the molecular weight of CO is 28 and it is normally a negligible percentage of the flue gas. These numbers indicate the CO₂ will need to be basically separated from the N₂ with a differential molecular weight of 16. After the CO₂ is separated from the flue gases, it can be compressed, injected into the ground, or used for other processes. In one embodiment of the present invention, the CO₂ is collected in a tank and then flowed up thru bubble trays containing sodium hydroxide which will cause the CO₂ to combine and produce sodium carbonate which can be collected for use otherwise. This embodiment is particularly useful in refineries and chemical plants where sodium hydroxide is commonly used in their processes (sometimes called "caustic soda"). After the sodium hydroxide is used, the plants use acid to reduce the used sodium hydroxide to a neutral PH so it can be disposed of. Using this byproduct does not require the purchase of gases and eliminates a disposal problem.

Now referring to FIGS. 1A, 1B and 1C, a cross sectional side view (FIG. 1A), a cross-sectional top view at cross section E-E (FIG. 1B), and a cross-sectional bottom view at cross section F-F (FIG. 1C) of a system 100 for separating

5

high molecular weight (HMW) gases **112** in an exhaust stack **102** from an exhaust gas **104** of a combustion source in accordance with one embodiment of the present invention are shown. A blower **106** is attached to an intake **108** of the exhaust stack **102** to receive the exhaust gas **104** from the combustion source (**502**, FIG. **5**) and create a tangential flow **110** of the exhaust gas **104** within the exhaust stack **102**. The blower **106** imparts sufficient centrifugal force on the exhaust gas **104** to concentrate the high molecular weight gases **112**, such as CO₂ or other gases having a higher molecular weight than N₂ or O₂ (e.g., greater than 35), along the inner perimeter or surface **114** of the exhaust stack **102**. As used herein, "along the inner perimeter or surface of the exhaust stack" means an area within the exhaust stack **102** that is much closer to the inner surface **114** of the exhaust stack **102** than to the center of the exhaust stack **102**. In other words, the high molecular weight gases **112** are concentrated near, towards or proximate to the inner surface **114** of the exhaust stack **102**. The low molecular weight gases **130** exit through the top of the exhaust stack **102**.

Typically, the blower **106** causes the exhaust gases **104** to spin around the interior of the exhaust stack **102** at least five times within a height approximately equal to one diameter (D) of the exhaust stack **102**. As shown, the blower **106** is external to the exhaust stack **102** and is connected to the intake **108** of the exhaust stack **102** with a first pipe **116**. A second pipe **118** connects the blower **106** to the bottom of the exhaust stack **102** at a point **120** approximately opposite to the intake **108** and in line with the tangential flow **110** in order to create the sufficient centrifugal force on the exhaust gas **104**. The use of a stationary tubulator, or spin vanes, or actual in-stack centrifuge may be necessary in addition to the blower **106**.

An interior vent **122** within the exhaust stack **102** collects the high molecular weight gases **112** concentrated along the inner surface **114** of the exhaust stack **102**. The interior vent **122** includes: (i) a vent wall *122ab* having a top portion **122a** attached to the interior surface **114** of the exhaust stack **102** along the entire inner perimeter of the exhaust stack **102** (e.g., the top portion **122a** is attached to the inner surface **114** along any side cross section of the exhaust stack **102**) and a lower portion **122b** that extends downward into the exhaust stack **102** to form an annular space or gap **124** between the vent wall **[122] lower portion 122b** and the interior surface **114** of the exhaust stack **102**; and (ii) at least one opening **122c** in the interior surface **114** of the exhaust stack **102** between the top **122a** and **[bottom] lower 122b** portions of the vent wall **[122] 122ab**. A transfer pipe **128** is connected to the at least one opening **122c** in the interior surface **114** of the exhaust stack **102** to remove the high molecular weight gases **112** from the interior vent **122**. The at least one or more openings **122c** can be holes, slots, or any other geometrically shaped passageway. Moreover, more than one transfer pipe **128** can be used. The lower portion **122b** of the vent wall **[122] 122ab** can be substantially parallel to the interior surface **114** of the exhaust stack **102**, curved or angled with respect to the interior surface **114** of the exhaust stack **102**. Note that the top portion **122a** of the interior vent **122** does not have to be aligned with a horizontal plane of the exhaust stack **102**. For example, the top portion **122a** can be angled from the horizontal plane in accordance with the tangential flow **110** (top portion **122a** on the opposite side of the exhaust stack **102** from the opening **122c** positioned lower than the top portion **122a** adjacent to the opening **122c**). For example, the top portion **122a** can form one or more spirals down from the one or more openings **122c**. In addition, an optional baffle or guide **122d** proximate to the

6

at least one opening **122c** can be used to direct the flow of the high molecular weight gases **112** from the interior vent **122** into the transfer pipe **128**. The baffle or guide **122d** can be straight, angled, curved or any other shape and orientation to more efficiently guide the high molecular weight gases **112** into the transfer pipe **128**.

The dimensions (A, B, C, D) of the vent wall **[122] 122ab** will vary in accordance with the design specifications for the system **100**. The design specification may take into account one or more parameters, such as temperature, humidity, velocity, gas composition, fuel type, or exhaust gas mixture. The system **100** dimensions should be configured to concentrate and capture at least 85% of the high molecular weight gases. The at least one opening **122c** is positioned at a height (A) such that the high molecular weight gases **112** have spun around the exhaust stack **102** approximately fifteen to twenty times or more. In one example, the at least one opening **122c** is positioned at a height (A) above the bottom of the exhaust stack **102** approximately equal to three diameters (3×D) of the exhaust stack **102**, the annular space or gap **124** has an area (B) of approximately 10% of a cross-sectional area of the exhaust stack **102**, and the **[bottom] lower portion [122a] 122b** of the vent wall **[122] 122ab** extends down a distance (C) approximately equal to one half diameter (0.5×D) of the exhaust stack **102**.

The system **100** may also include other components, such as a tank (**504**, FIG. **5**) connected to the transfer pipe **128** to store the removed high molecular weight gases **112**, a compressor attached to the transfer pipe **128** to compress the removed high molecular weight gases **112** (**506**, FIG. **5**), a motor (*not shown*) attached to the vent wall **[122] 122ab** that adjusts a size of the annular space or gap **124** based on one or more parameters (e.g., temperature, humidity, velocity, gas composition, fuel type, or exhaust gas mixture, etc.), and/or one or more sensors (*not shown*) attached to the blower **106**, exhaust stack **102**, interior vent **122** or transfer pipe **128**. A controller (*not shown*) can be communicably coupled to the motor (*not shown*) and the one or more sensors to adjust the size (B) of the annular space or gap **124** using the motor based on one or more parameters detected by the one or more sensors. As previously discussed, one or more bubble trays (**508**, FIG. **5**) containing sodium hydroxide can be attached to the transfer pipe **128** or tank such that the removed CO₂ is combined with the sodium hydroxide to produce sodium carbonate.

Referring now to FIGS. **2A**, **2B** and **2C**, a cross-sectional side view (FIG. **2A**), a cross-sectional top view at cross section E-E (FIG. **2B**) and a cross-sectional bottom view at cross section F-F (FIG. **2C**) of the system **200** for separating high molecular weight (HMW) gases **112** in an exhaust stack **102** from an exhaust gas **104** of a combustion source in accordance with one embodiment of the present invention are shown. A blower **106** is attached to an intake **108** of the exhaust stack **102** to receive the exhaust gas **104** from the combustion source (**502**, FIG. **5**) and create a tangential flow **110** of the exhaust gas **104** within the exhaust stack **102**. The blower **106** imparts sufficient centrifugal force on the exhaust gas **104** to concentrate the high molecular weight gases **112**, such as CO₂ or other gases having a higher molecular weight greater than N₂ or O₂ (e.g., greater than 35), along the inner perimeter or surface **114** of the exhaust stack **102**. Typically, the blower **106** causes the exhaust gases **104** to spin around the interior of the exhaust stack **102** at least five times within a height approximately equal to one diameter (D) of the exhaust stack **102**.

As shown, the blower **106** is external to the exhaust stack **102** and is connected to the intake **108** of the exhaust stack

102 with a first pipe 116. A second pipe 118 connects the blower 106 to the bottom of the exhaust stack 102 at a point 120 approximately opposite to the intake 108 and in line with the tangential flow 110 in order to create the sufficient centrifugal force on the exhaust gas 104. The use of a stationary tubulator, or spin vanes, or actual in-stack centrifuge may be necessary in addition to the blower 106.

An interior vent 122 within the exhaust stack 102 collects the high molecular weight gases 112 concentrated along the inner surface 114 of the exhaust stack 102. The interior vent 122 includes: (i) a vent wall 122ab having a top portion 122a attached to the interior surface 114 of the exhaust stack 102 along the entire inner perimeter of the exhaust stack 102 (e.g., the top portion 122a is attached to the inner surface 114 along any side cross section of the exhaust stack 102) and a lower portion 122b that extends downward into the exhaust stack 102 to form an annular space or gap 124 between the vent wall [122] 122ab and the interior surface 114 of the exhaust stack 102; (ii) at least one opening 122c in the interior surface 114 of the exhaust stack 102 between the top 122a and [bottom] lower 122b portions of the vent wall [122] 122ab; and (iii) a bustle 202 attached to or integrated into the exhaust stack 102 between the at least one opening 122c in the inner surface 114 of the exhaust stack 102 and a transfer pipe 128. The transfer pipe 128 is connected to bustle 202 to remove the high molecular weight gases 112 from the interior vent [122] 122ab. The at least one or more openings 122c can be holes, slots, or any other geometrically shaped passageway. Moreover, more than one transfer pipe 128 can be used. The lower portion 122b of the vent wall [122] 122ab can be substantially parallel to the interior surface 114 of the exhaust stack 102, curved or angled with respect to the interior surface 114 of the exhaust stack 102. Note that the top portion 122a of the interior vent [122] 122ab does not have to be aligned with a horizontal plane of the exhaust stack 102. For example, the top portion 122a can be angled from the horizontal plane in accordance with the tangential flow 110 (top portion 122a on the opposite side of the exhaust stack 102 from the opening 122c positioned lower than the top portion 122a adjacent to the opening 122c). For example, the top portion 122a can form one or more spirals down from the one or more openings 122c. In addition, an optional baffle or guide 122d proximate to the at least one opening 122c can be used to direct the flow of the high molecular weight gases 112 from the interior vent 122 into the transfer pipe 128. The baffle or guide 122d can be straight, angled, curved or any other shape and orientation to more efficiently guide the high molecular weight gases 112 into the transfer pipe 128.

The dimensions (A, B, C, D) of the vent wall [122] 122ab will vary in accordance with the design specifications for the system 200. The design specification may take into account one or more parameters, such as temperature, humidity, velocity, gas composition, fuel type, or exhaust gas mixture. The system 200 dimensions should be configured to concentrate and capture at least 85% of the high molecular weight gases. The at least one opening 122c is positioned at a height (A) such that the high molecular weight gases 112 have spun around the exhaust stack 102 approximately fifteen to twenty times or more. In one example, the at least one opening 122c is positioned at a height (A) above the bottom of the exhaust stack 102 approximately equal to three diameters ($3 \times D$) of the exhaust stack 102, the annular space or gap 124 has an area (B) of approximately 10% of a cross-sectional area of the exhaust stack 102, and the [bottom] lower portion [122a] 122b of the vent wall [122]

122ab extends down a distance (C) approximately equal to one half diameter ($0.5 \times D$) of the exhaust stack 102.

The system 100 may also include other components, such as a tank (504, FIG. 5) connected to the transfer pipe 128 to store the removed high molecular weight gases 112, a compressor attached to the transfer pipe 128 to compress the removed high molecular weight gases 112 (506, FIG. 5), a motor (*not shown*) attached to the vent wall [122] 122ab that adjusts a size of the annular space or gap 124 based on one or more parameters (e.g., temperature, humidity, velocity, gas composition, fuel type, or exhaust gas mixture, etc.), and/or one or more sensors (*not shown*) attached to the blower 106, exhaust stack 102, interior vent 122 or transfer pipe 128. A controller (*not shown*) can be communicably coupled to the motor and the one or more sensors to adjust the size (B) of the annular space or gap 124 using the motor based on one or more parameters detected by the one or more sensors. As previously discussed, one or more bubble trays (508, FIG. 5) containing sodium hydroxide can be attached to the transfer pipe 128 or tank such that the removed CO_2 is combined with the sodium hydroxide to produce sodium carbonate.

Now referring to FIGS. 3A, 3B and 3C, a cross sectional side view (FIG. 3A), a cross-sectional top view at cross section E-E (FIG. 3B) and a cross-sectional bottom view at cross section F-F (FIG. 3C) of the system 300 for separating high molecular weight (HMW) gases in an exhaust stack 102 from an exhaust gas 104 of a combustion source in accordance with one embodiment of the present invention are shown. A blower 106 is attached to an intake 108 of the exhaust stack 102 to receive the exhaust gas 104 from the combustion source (502, FIG. 5) and create a tangential flow 110 of the exhaust gas 104 within the exhaust stack 102. The blower 106 imparts sufficient centrifugal force on the exhaust gas 104 to concentrate the high molecular weight gases 112, such as CO_2 or other gases having a higher molecular weight greater than N_2 or O_2 (e.g., greater than 35), along the inner perimeter or surface 114 of the exhaust stack 102. Typically, the blower 106 causes the exhaust gases 104 to spin around the interior of the exhaust stack 102 at least five times within a height approximately equal to one diameter (D) of the exhaust stack 102. As shown, the blower 106 is internal to the exhaust stack 102. A second pipe 118 or channel connects the blower 106 to the bottom of the exhaust stack 102 at a point 120 approximately opposite to the intake 108 and in line with the tangential flow 110 in order to create the sufficient centrifugal force on the exhaust gas 104. The use of a stationary tubulator, or spin vanes, or actual in-stack centrifuge may be necessary in addition to the blower 106.

An interior vent 122 within the exhaust stack 102 collects the high molecular weight gases 112 concentrated along the inner surface 114 of the exhaust stack 102. The interior vent 122 includes: (i) a vent wall 122ab having a top portion 122a attached to the interior surface 114 of the exhaust stack 102 along the entire inner perimeter of the exhaust stack 102 (e.g., the top portion 122a is attached to the inner surface 114 along any side cross section of the exhaust stack 102) and a lower portion 122b that extends downward into the exhaust stack 102 to form an annular space or gap 124 between the vent wall [122] 122ab and the interior surface 114 of the exhaust stack 102; (ii) at least one opening 122c in the interior surface 114 of the exhaust stack 102 between the top 122a and [bottom] lower 122b portions of the vent wall [122] 122ab; and (iii) a bustle 202 attached to or integrated into the exhaust stack 102 between the at least one opening 122c in the inner surface 114 of the exhaust stack 102 and

a transfer pipe 128. The transfer pipe 128 is connected to bustle 202 to remove the high molecular weight gases 112 from the interior vent 122. The at least one or more openings 122c can be holes, slots, or any other geometrically shaped passageway. Moreover, more than one transfer pipe 128 can be used. The lower portion 122b of the vent wall [122] 122ab can be substantially parallel to the interior surface 114 of the exhaust stack 102, curved or angled with respect to the interior surface 114 of the exhaust stack 102. Note that the top portion 122a of the interior vent 122 does not have to be aligned with a horizontal plane of the exhaust stack 102. For example, the top portion 122a can be angled from the horizontal plane in accordance with the tangential flow 110 (top portion 122a on the opposite side of the exhaust stack 102 from the opening 122c positioned lower than the top portion 122a adjacent to the opening 122c). For example, the top portion 122a can form one or more spirals down from the one or more openings 122c. In addition, an optional baffle or guide 122d proximate to the at least one opening 122c can be used to direct the flow of the high molecular weight gases 112 from the interior vent 122 into the transfer pipe 128. The baffle or guide 122d can be straight, angled, curved or any other shape and orientation to more efficiently guide the high molecular weight gases 112 into the transfer pipe 128).

The dimensions (A, B, C, D) of the vent wall [122] 122ab will vary in accordance with the design specifications for the system 300. The design specification may take into account one or more parameters, such as temperature, humidity, velocity, gas composition, fuel type, or exhaust gas mixture. The system 300 dimensions should be configured to concentrate and capture at least 85% of the high molecular weight gases. The at least one opening 122c is positioned at a height (A) such that the high molecular weight gases 112 have spun around the exhaust stack 102 approximately fifteen to twenty times or more. In one example, the at least one opening 122c is positioned at a height (A) above the bottom of the exhaust stack 102 approximately equal to three diameters ($3 \times D$) of the exhaust stack 102, the annular space or gap 124 has an area (B) of approximately 10% of a cross-sectional area of the exhaust stack 102, and the [bottom] lower portion [122a] 122b of the vent wall [122] 122ab extends down a distance (C) approximately equal to one half diameter ($0.5 \times D$) of the exhaust stack 102.

The system 100 may also include other components, such as a tank (504, FIG. 5) connected to the transfer pipe 128 to store the removed high molecular weight gases 112, a compressor attached to the transfer pipe 128 to compress the removed high molecular weight gases 112 (506, FIG. 5), a motor (not shown) attached to the vent wall [122] 122ab that adjusts a size of the annular space or gap 124 based on one or more parameters (e.g., temperature, humidity, velocity, gas composition, fuel type, or exhaust gas mixture, etc.), and/or one or more sensors (not shown) attached to the blower 106, exhaust stack 102, interior vent 122 or transfer pipe 128. A controller (not shown) can be communicably coupled to the motor and the one or more sensors to adjust the size (B) of the annular space or gap 124 using the motor based on one or more parameters detected by the one or more sensors. As previously discussed, one or more bubble trays (508, FIG. 5) containing sodium hydroxide can be attached to the transfer pipe 128 or tank such that the removed CO_2 is combined with the sodium hydroxide to produce sodium carbonate.

Referring now to FIG. 4, a flow chart of a method 400 for separating high molecular weight gases in an exhaust stack from an exhaust gas of a combustion source in accordance with one embodiment of the present invention is shown. The

following components are provided in block 402 to perform the method 400: (a) a blower attached to an intake of an exhaust stack to receive the exhaust gas from the combustion source, (b) an interior vent within the exhaust stack comprising (i) a vent wall having a top portion attached to the interior surface of the exhaust stack along the entire inner perimeter of the exhaust stack and a lower portion that extends downward into the exhaust stack to form an annular space or gap between the vent wall and the interior surface of the exhaust stack, and (ii) at least one opening in the interior surface of the exhaust stack between the top and bottom portions of the vent wall, and (c) a transfer pipe connected to the at least one opening in the interior surface of the exhaust stack. A tangential flow of the exhaust gas within the exhaust stack is created using the blower in block 404. The blower imparts sufficient centrifugal force on the exhaust gas to concentrate substantially all of the high molecular weight gases along the inner surface of the exhaust stack. The high molecular weight gases concentrated along the inner surface of the exhaust stack are collected using the interior vent in block 406. The high molecular weight gases are removed from the interior vent using the transfer pipe in block 408.

Additional steps may include storing the removed high molecular weight gases in a tank (504, FIG. 5) connected to the transfer pipe, compressing the removed high molecular weight gases (506, FIG. 5), injecting the removed high molecular weight gases into a below-ground storage, or flowing the removed CO_2 up through one or more bubble trays containing sodium hydroxide which causes the removed CO_2 to combine with the sodium hydroxide to produce sodium carbonate (508, FIG. 5).

Now referring to FIG. 5, a block diagram of a system 500 incorporating the embodiments of the present invention is shown. As previously described, the combustion source 502 creates exhaust 104, which is transported to the exhaust stack 102 (not specifically illustrated in FIG. 5) of system 100, 200 or 300. Low molecular gas 130 exits the exhaust stack [100, 200 or 300]. The high molecular weight gas 112 is collected and removed from the exhaust stack [100, 200 or 300] for further processing (e.g., storage in a tank 504, compression followed by storage 506, bubble trays to produce sodium carbonate 508, etc.). The high molecular weight gas 112 can be used in other ways as will be appreciated and known by those skilled in the art.

The various illustrative logical blocks, modules, circuits, and algorithm steps described herein may be implemented as electronic hardware, computer software, or combinations of both, depending on the application and functionality. Moreover, the various logical blocks, modules, and circuits described herein may be implemented or performed with a general purpose processor (e.g., microprocessor, conventional processor, controller, microcontroller, state machine or combination of computing devices), a digital signal processor ("DSP"), an application specific integrated circuit ("ASIC"), a field programmable gate array ("FPGA") or other programmable logic device, discrete gate or transistor logic, discrete hardware components, or any combination thereof designed to perform the functions described herein. Similarly, steps of a method or process described herein may be embodied directly in hardware, in a software module executed by a processor, or in a combination of the two. A software module may reside in RAM memory, flash memory, ROM memory, EPROM memory, EEPROM memory, registers, hard disk, a removable disk, a CD-ROM, or any other form of storage medium known in the art. Although preferred embodiments of the present invention

11

have been described in detail, it will be understood by those skilled in the art that various modifications can be made therein without departing from the spirit and scope of the invention as set forth in the appended claims.

What is claimed is:

1. A method for separating high molecular weight gases from an exhaust gas of a combustion source comprising the steps of:

providing (a) a blower attached to an intake of an exhaust stack to receive the exhaust gas from the combustion source, (b) an interior vent within the exhaust stack comprising (i) a vent wall having a top portion attached to [the] an interior surface of the exhaust stack along the entire inner perimeter of the exhaust stack and a lower portion that extends downward into the exhaust stack to form a gap between the vent wall and the interior surface of the exhaust stack, and (ii) at least one opening in the interior surface of the exhaust stack between the top and bottom portions of the vent wall, and (c) a transfer pipe connected to the at least one opening in the interior surface of the exhaust stack;

concentrating the high molecular weight gases along the inner surface of the exhaust stack by creating a tangential flow of the exhaust gas within the exhaust stack using the blower, wherein the blower imparts sufficient centrifugal force on the exhaust gas to concentrate substantially all of the high molecular weight gases along the inner surface of the exhaust stack];

collecting the high molecular weight gases concentrated along the inner surface of the exhaust stack using the interior vent; and

removing the high molecular weight gases from the interior vent using the transfer pipe.

2. The method as recited in claim 1, further comprising the steps of:

storing the removed high molecular weight gases in a tank connected to the transfer pipe;

compressing the removed high molecular weight gases; or injecting the removed high molecular weight gases into a below-ground storage.

3. The method as recited in claim 1, wherein the high molecular weight gases have a molecular weight greater than 35.

4. The method as recited in claim 1, wherein the high molecular weight gases comprise CO₂.

5. The method as recited in claim 4, further comprising the step of flowing the removed CO₂ up through one or more bubble trays containing sodium hydroxide [which causes the removed CO₂ to combine with the sodium hydroxide to produce sodium carbonate].

[6. The method as recited in claim 1, wherein: the sufficient centrifugal force is provided by the blower in combination with a stationary tabulator, spin vanes, or in-stack centrifuge; and the blower is located inside or outside of the exhaust stack.]

7. The method as recited in claim 1, further comprising *providing* a bustle attached to or integrated into the exhaust stack between the at least one opening in the inner surface of the exhaust stack and the transfer pipe.

8. The method as recited in claim 1, wherein the *lower portion of the vent wall* is substantially parallel to the interior surface of the exhaust stack, curved, or [is] angled with respect to the interior surface of the exhaust stack.

9. The method as recited in claim 1, wherein *the concentrating the high molecular weight gases along the inner surface of the exhaust stack comprises concentrating at least*

12

85% of the high molecular weight gases [are concentrated] along the inner surface of the exhaust stack.

10. The method as recited in claim 1, wherein the gap comprises an area of approximately 10% of a cross-sectional area of the exhaust stack.

11. The method as recited in claim 1, wherein the at least one opening is positioned such that the high molecular weight gases have spun around the exhaust stack approximately fifteen to twenty times *prior to reaching the at least one opening*.

12. The method as recited in claim 1, wherein the blower causes the exhaust gases to spin around the exhaust stack at least five times within a height approximately equal to one diameter of the exhaust stack.

13. The method as recited in claim 1, wherein the at least one opening is positioned at a height above [the] a bottom of the exhaust stack approximately equal to three diameters of the exhaust stack.

14. The method as recited in claim 1, wherein the [bottom] lower portion of the vent wall extends down to a height above [the] a bottom of the exhaust stack approximately equal to one half diameter of the exhaust stack.

15. The method as recited in claim 1, further comprising [a motor attached to] *moving* the vent wall [that adjusts] to *adjust* a size of the gap.

16. The method as recited in claim 15, wherein the [motor] *step of moving* is used to adjust the size of the gap based on one or more parameters comprising temperature, humidity, velocity, gas composition, fuel type, or exhaust gas mixture.

[17. The method as recited in claim 15, further comprising:

one or more sensors attached to the blower, exhaust stack, interior vent or transfer pipe; and

a controller communicably coupled to the motor and the one or more sensors, wherein the controller to adjusts the size of the gap using the motor based on one or more parameters detected by the one or more sensors.]

18. *The method as recited in claim 9, wherein concentrating the high molecular weight gases along the inner surface of the exhaust stack comprises concentrating substantially all of the high molecular weight gases along the inner surface of the exhaust stack.*

19. *The method as recited in claim 16, further comprising: sensing the one or more parameters of the exhaust gas at the blower, exhaust stack, interior vent, or transfer pipe; and*

controlling the step of moving the vent wall to adjust the size of the gap based on the sensed one or more parameters.

20. *A method for removing high molecular weight gases from an exhaust stream, comprising:*

introducing exhaust gas tangentially into an exhaust stack;

concentrating high molecular weight gases toward an inner surface of the exhaust stack by spinning the exhaust gas and imparting centrifugal force; and removing gases from along the inner surface of the exhaust stack;

wherein the spinning the exhaust gas and imparting centrifugal force comprises accelerating exhaust gas that is spinning within the stack; and

wherein the accelerating exhaust gas comprises removing exhaust gas tangentially from one side of the exhaust

*stack and blowing it tangentially back into the exhaust
stack on a side opposite the one side.*

* * * * *