

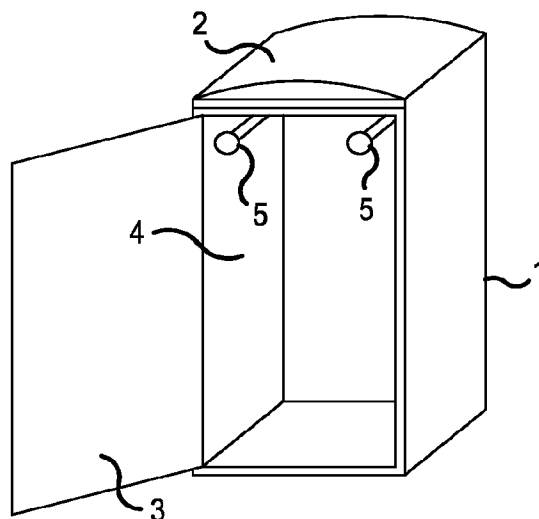

(86) **Date de dépôt PCT/PCT Filing Date:** 2016/02/02
 (87) **Date publication PCT/PCT Publication Date:** 2016/08/11
 (45) **Date de délivrance/Issue Date:** 2020/03/10
 (85) **Entrée phase nationale/National Entry:** 2017/07/20
 (86) **N° demande PCT/PCT Application No.:** US 2016/016168
 (87) **N° publication PCT/PCT Publication No.:** 2016/126704
 (30) **Priorités/Priorities:** 2015/02/05 (US62/112,465);
 2015/09/15 (US14/854,913)

(51) **Cl.Int./Int.Cl. B65F 1/14** (2006.01),
A47B 81/00 (2006.01), **A47F 13/08** (2006.01),
A47G 29/00 (2006.01), **B65B 67/12** (2006.01),
B65F 1/06 (2006.01), **B65F 1/16** (2006.01)
 (72) **Inventeur/Inventor:**
 CASTRO, DEJA S., US
 (73) **Propriétaire/Owner:**
 RDC SYSTEMS, LLC, US
 (74) **Agent:** AIRD & MCBURNEY LP

(54) **Titre : DISTRIBUTEUR DE SACS A ORDURES DE RECIPIENT D'ORDURES**
 (54) **Title: TRASH RECEPTACLE GARBAGE BAG DISPENSER**



(57) **Abrégé/Abstract:**

A trash receptacle capable of receiving and dispensing garbage bags. The receptacle may include a compartment enclosed by walls of the trash receptacle, the compartment being the enclosure for receiving trash, two parallel and planar horizontal bars or rods within the compartment, with the bars or rods being structurally configured to receive and dispense garbage bags. The receptacle may also have a lid over the compartment, the lid providing access into the compartment.

(12) INTERNATIONAL APPLICATION PUBLISHED UNDER THE PATENT COOPERATION TREATY (PCT)

(19) World Intellectual Property
Organization
International Bureau(10) International Publication Number
WO 2016/126704 A1(43) International Publication Date
11 August 2016 (11.08.2016)

(51) International Patent Classification:

B65F 1/06 (2006.01) *B65D 25/10* (2006.01)
B65F 1/14 (2006.01) *B65D 83/00* (2006.01)
F16B 2/20 (2006.01) *B65D 85/00* (2006.01)
B65F 1/16 (2006.01) *B65D 43/14* (2006.01)
B65D 25/02 (2006.01)

(21) International Application Number:

PCT/US2016/016168

(22) International Filing Date:

2 February 2016 (02.02.2016)

(25) Filing Language:

English

(26) Publication Language:

English

(30) Priority Data:

62/112,465 5 February 2015 (05.02.2015) US
 14/854,913 15 September 2015 (15.09.2015) US

(72) Inventor; and

(71) Applicant : **CASTRO, Deja, S.** [US/US]; 30141 Antelope Rd. D755, Menifee, CA 92584 (US).(74) Agent: **EVANS, Andrea, H.**; The Law Firm of Andrea Hence Evans, LLC, 14625 Baltimore Ave. #853, Laurel, MD 20707 (US).

(81) Designated States (unless otherwise indicated, for every kind of national protection available): AE, AG, AL, AM, AO, AT, AU, AZ, BA, BB, BG, BH, BN, BR, BW, BY, BZ, CA, CH, CL, CN, CO, CR, CU, CZ, DE, DK, DM, DO, DZ, EC, EE, EG, ES, FI, GB, GD, GE, GH, GM, GT, HN, HR, HU, ID, IL, IN, IR, IS, JP, KE, KG, KN, KP, KR, KZ, LA, LC, LK, LR, LS, LU, LY, MA, MD, ME, MG, MK, MN, MW, MX, MY, MZ, NA, NG, NI, NO, NZ, OM, PA, PE, PG, PH, PL, PT, QA, RO, RS, RU, RW, SA, SC, SD, SE, SG, SK, SL, SM, ST, SV, SY, TH, TJ, TM, TN, TR, TT, TZ, UA, UG, US, UZ, VC, VN, ZA, ZM, ZW.

(84) Designated States (unless otherwise indicated, for every kind of regional protection available): ARIPO (BW, GH, GM, KE, LR, LS, MW, MZ, NA, RW, SD, SL, ST, SZ, TZ, UG, ZM, ZW), Eurasian (AM, AZ, BY, KG, KZ, RU, TJ, TM), European (AL, AT, BE, BG, CH, CY, CZ, DE, DK, EE, ES, FI, FR, GB, GR, HR, HU, IE, IS, IT, LT, LU, LV, MC, MK, MT, NL, NO, PL, PT, RO, RS, SE, SI, SK, SM, TR), OAPI (BF, BJ, CF, CG, CI, CM, GA, GN, GQ, GW, KM, ML, MR, NE, SN, TD, TG).

Declarations under Rule 4.17:

— of inventorship (Rule 4.17(iv))

Published:

— with international search report (Art. 21(3))

(54) Title: TRASH RECEPTACLE GARBAGE BAG DISPENSER

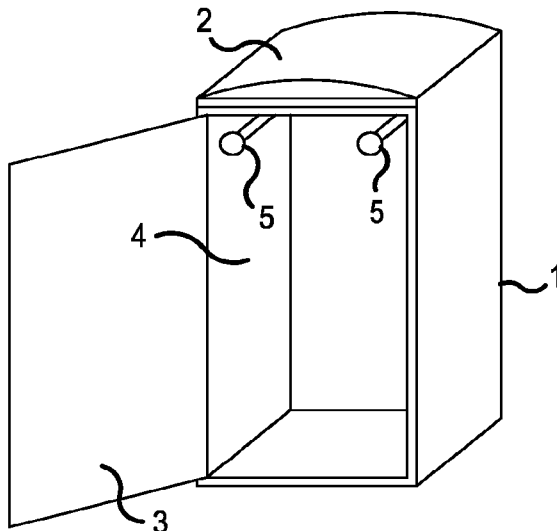

FIG. 3

(57) Abstract: A trash receptacle capable of receiving and dispensing garbage bags. The receptacle may include a compartment enclosed by walls of the trash receptacle, the compartment being the enclosure for receiving trash, two parallel and planar horizontal bars or rods within the compartment, with the bars or rods being structurally configured to receive and dispense garbage bags. The receptacle may also have a lid over the compartment, the lid providing access into the compartment.

TRASH RECEPTACLE GARBAGE BAG DISPENSER

5

FIELD OF THE INVENTION

The present invention relates, in general, to a trash receptacle structurally and
10 functionally designed to ease the installation and removal of garbage bags.

BACKGROUND OF THE INVENTION

Typical trash cans/receptacles allow for the installation of bags within and require
removal that exposes the trash. Bag replacement could also take time as one
would have to first remove the first bag (which would be full of trash) and then
15 obtain and place a new bag in the trash can/receptacle. Removal is also hampered
or made difficult as a result of having to lift the bag out of the trash
can/receptacle.

People use trash bags at home and work but often find creative portable ways to
bring them along. People tie them on door knobs at parties, tie them to the truck
20 bed or side mirrors during a tail gate party. People also tie them to fences, railings,
trees, tables, barbeques, chairs, etc. In doing so, they use regular shaped trash bags
that may not, for the most part, be suitable or effective for their application. As
such, people try to find ways to make the bags they use work for their use by
hanging, clipping, tying or wrapping them around portable rims, stands, etc.
25 However, they fail to find better ways to enable the efficient dispensing and
installation of their trash bags.

Some typical grocery bag racks are also not able to hide the contents of the bags
since the racks are not enclosed. These grocery bag racks cannot contain smells of

their contents since they do not have lids. If spills occur from a ripped bag, the racks have difficulty containing the spill in an enclosed area since most grocery store bag racks have flat bases without fluid catching capability. Some bag racks that arc in the grocery store checkout area are designed to allow the opening of
5 grocery bags over a small area of space and thus are not able to accommodate a larger bag that would be able to hold a substantial amount of trash.

Trash cabinets, bins, and all types of receptacles are enclosed and can hide the bag and the bag contents easily. Trash receptacles usually have a top or lid available to contain the smell of the trash. They usually have an enclosed bottom in case of a
10 spill. However, they do not have an easy way to organize bags or allow for rapid bag changing. Most trash receptacles cannot accommodate bags with holes in them since they do not have rods in place to receive such bags.

Many businesses and homes have custom cabinetry or basic cabinet structures. Many companies have offered slide out flat base drawers to make room for a trash
15 can to be set inside of that drawer. While this option can hide a trash can it does not offer the fast, clean, and organized method that an aspect of an embodiment of the present invention could offer by the simple conversion of adding two straight parallel bag holding bars or rods.

Most of the rods/bars that are found inside receptacles in prior art are used for
20 different functions and are designed as such. Some prior art rods are used to hold the type of bags that are on a roll. In contrast, aspects of embodiments of the present invention contemplate the use of bags that may be in a stack and may remain inside a firm package while hanging and dispensing by holes that are in the bags (meant for dispensing the bags and also their installation). Most prior art rods
25 are short in length, not able to allow one leading bag to be pulled away from the stack in the rear area of the receptacle and ride along into the center area of the receptacle, where it is in the fully open, ready to use position, where it needs continued firm support. The prior art is designed with obvious notches, or protruding clips on the bars for the user to open one bag at a time and position it
30 by hand by clipping or hanging it into position. Most of the prior art, two bar or

rod type of mechanisms, are shaped for the hanging of a grocery bag by the handle, so it can be used a second time as a trash bag. The prior art bars, because of their short length or shape do not allow a large quantity of bags to load nor do they offer the ability for one bag to open and move into the ready to use position.

5 Many prior art receptacles have parallel bars in them; the bars are generally described as being part of the structure to keep the receptacle frame up and supported. Some of the prior art bars move and become like a blender or shredder inside a receptacle to disintegrate the trash. Some of the prior art parallel bars are used as tracks or rails for a plate or wall to move on so it can become a compactor.

10 Some prior art bars/rods are used to connect the lid to the pedal so they can function together to allow the lid to lift once the pedal is depressed. Almost all of the prior art parallel bars are connected at two opposite sides of the receptacle where they touch the opposite walls, therefore, not allowing someone access to one side in order to load on bags in a stack nor allow a full bag to be slid off of

15 one free hanging side to exit the receptacle. Some prior art rods are “b” shaped or have significant curves at the free hanging end of the bar or rod where the bags are loaded and also large curves at the end which connects to the rear support wall. The problem with these curves is that they do not allow a tall, firm, thick package of bags (as needed for trash bag purposes), to be loaded onto the strongly curved

20 end of the bar/rod easily and sometimes at all. Strong curves at the loading area of the bar or rod also require wasted time to manipulate the package onto the curves. The problem at the rear area of the prior art bar with the strong curves is that they do not allow the package to sit correctly or balance evenly. The strong “b” curve at the rear end that connects to the back wall area prevents the bags from easily

25 deploying one by one. With these structural and design limitations, bags get snagged, torn, and stuck from the rear curve and cause major time delay in having to clean up or find ways to remove the bags efficiently. In contrast, for optimal utility an aspect of an embodiment of the present invention contemplates use of bars that may be straight from the free hanging loading area all the way to the

30 connection area of the rear part of the bar.

Previous bag dispensing apparatuses are designed to be stationary and are not easily transported. They are also not marketed nor designed to be portable or designed to be attached to other surfaces for other purposes. These types of racks are specific to t-shirt handle style bags.

- 5 In light of the foregoing problems, there exists a need for a much more efficiently designed trash can/receptacle which enables speedier bag replacement, and maintains odor control among other things.

SUMMARY OF THE INVENTION

The trash receptacle rack/bar or rod system as contemplated by the present
10 invention, enable various utility options which may include, *inter alia*: 1. Adding lids to racks similar to the prior art of plastic bag grocery store racks to allow that function to now be “enclosed” and also used for trash purposes. 2. Creating an enclosure for straight parallel bar or rod bag hanging systems by adding walls around them or using them inside cabinetry to allow the bag and its contents to be
15 out of plain view, and 3. Creating a new portable, adjustable, bag hanging bar or rod device for outdoors, indoors, that could be used anywhere people need a portable, two straight parallel bag hanging bar or rod device to load bags on with an optional lid. These options offer the same utility function while solving many unmet areas in life that are trash related. They all are designed for bags that hang
20 from holes in them and need bars to allow them to load onto the bars, allow storing of a set of bags at the rear area of the bars, and allow the bags to be able to move along the bars to open for use and exit the bar or rod to be disposed of once they are full of trash. All of the functions and purposes as disclosed in this disclosure may be used with plastic bags that are for trash and bags that are for
25 any purpose. The demands of the rods/bars for the purposes of this disclosure are structured and designed in order to function effectively and efficiently for the needs of a typical trash bag scenario.

One object of the present invention is to promote quick, smooth loading of a large set of generally tall bags. An aspect of an embodiment of the present invention
30 provides a well fit bag to stay close to the rods so the bag does not sag at any point

along the rods. A further aspect of an embodiment of the present invention allows the motion of removing the full bag to prompt the next bag, which is usually connected to the first bag, so it will smoothly deploy without any interference and without a person having to stop and manually place the next bag into position.

5 Aspects of embodiments of the present invention contemplate enabling the use of different bags including those that may be very flexible and thin which may be easily loaded onto bars/rods as the bags are not loaded while inside of a package and because the shape of the bag and hole alignment is easy to manipulate by hand in order to load them onto the bars. The free hanging rods/bars contemplated
10 in the present invention also allow for the bags to be easily loaded onto the rods/bars and to dispensing the bags for use. In an aspect of an embodiment of the present invention, the bars/rods may be generally straight with a minor curve to facilitate loading the bags or keep the bag from easily falling or sliding off the bars/rods.

15 An aspect of an embodiment of the present invention contemplates a trash receptacle that eases the installation and removal of garbage bags while also maintaining odor control, among other distinct advantages. An aspect of an embodiment of the present invention contemplates a trash receptacle which may include a compartment enclosed by walls of the trash receptacle, where the
20 compartment may be an enclosure configured to receive trash, two planar horizontal bars or rods which may be parallel with each other within the compartment, where the bars or rods may be structurally configured to receive and dispense garbage bags, and a lid over the compartment, the lid providing access into the compartment. The lid, or top surface of the receptacle can be solid, or
25 with an opening such as a top drop style. The door can allow easy trash deposit by being a swing or flip style door, if desired. Any type of opening can be used to deposit trash. In one aspect of an embodiment of the present invention, the bars may be affixed within the compartment.

An aspect of an embodiment of the present invention contemplates a trash
30 receptacle apparatus that could be used in cabinets, stands, racks, etc. having an

enclosed set(s) of parallel bars that are used to hang and move bags on. Another aspect contemplates a portable device that may be enclosed if desired. It should be noted that the term “enclosed” can, *inter alia*, refer to adding a lid to close off the top of a bag that is hanging on the bars of any type of bag rack; a user can
5 “enclose” a bag by using a lid without walls if desired. The term “enclosed” can also refer to enclosing the bag that hangs on bars by adding walls of any material and an optional door at any location along with the lid if desired.

An aspect of an embodiment of the present invention contemplates a trash receptacle apparatus having straight parallel rods/bars in order to enable fast easy
10 loading of thick, firm, and tall packages of very large bags, and easy pull deployment without any interference of curves in the rear or front end of the rod/bars. One aspect of an embodiment of the present invention contemplates having minor curves for style that do not slow down loading, dispensing, and removing the bags.

15 An aspect of an embodiment of the present invention contemplates multiple sets of rods/bars that may be used inside one receptacle/cabinet so that many bags can be used at one time. The bags can be used for recycling, compost, trash, etc. all at one location. The rods/bars with bags can be all in one compartment or have dividers to create separate compartments.

20 In an aspect of an embodiment of the present invention, one end of each bar or rod may be secured to an inside wall of the compartment. In an aspect, each other end of each bar or rod be free hanging and unsupported/non-affixed. As such, garbage bags may be installed onto the bars or rods by way of the free hanging, unsupported ends of the bars.

25 In an aspect of an embodiment of the present invention, access to the receptacle compartment for installing garbage bags may be made possible by way of any one of a front door, side door or the lid.

In an aspect of an embodiment of the present invention, the bars or rods may be structurally configured to hold garbage bags in a stack.

In an aspect of an embodiment of the present invention, the bars or rods may be structurally configured to receive and dispense garbage bags with punch holes. In operation, a user may draw a garbage bag which, in turn may be connected to another garbage bag. The drawn garbage bag, because of the user's pull, is drawn
5 open. The punch holes enable detachment from other bags when the bag is drawn by the user.

In an aspect of an embodiment of the present invention, the trash receptacle may further include a drip tray/pan located at the base of the compartment.

In an aspect of an embodiment of the present invention, the bars or rods may be
10 secured to any one of the following: any wall of the compartment, lid of the receptacle, floor/base of the receptacle, frame of the receptacle, door of the receptacle, ceiling of the receptacle.

In an aspect of an embodiment of the present invention, the bars or rods may be
15 can be on a track/rail system where the track/rail system enables the bars or rods for motion in any one of the following directions within, and in relation to, the compartment: up, down, side to side or front to back.

In an aspect of an embodiment of the present invention, the bars or rods may be
20 affixed to a panel within the compartment. This panel, according to another aspect of an embodiment of the present invention, may include multiple sets of attachment positions to enable bar or rod attachment settings at different heights.

In an aspect of an embodiment of the present invention, the panel may include a track to which the bars may be secured to or affixed and where the track is able to vertically slide up or down the panel to enable different bar or rod setting heights.

In an aspect of an embodiment of the present invention, the bars or rods may have
25 a bag position holding mechanism that keeps the bag from moving backwards/collapsing or from moving forward/ falling off the bars.

In an aspect of an embodiment of the present invention, the receptacle may include a clip mechanism at each free non-affixed end of each bar, where each

clip mechanism is configured to receive the edge of an installed bag and functions to help detach the bag. The clip mechanism also prevents the installed bag from sliding off the bars. In an aspect of an embodiment of the present invention, the clip/clasp mechanism could be any size, material; it could be molded onto the bars, attached as a separate piece, it could be any shape, etc. The clip mechanism is for the purpose of keeping the bag in a set position so it cannot close inward or fall off. In another aspect of an embodiment of the present invention, the clip/clasp mechanism may be located on the bars/rods- top side, left or right sides, the bottom side or be on the outside front edge /tip of the bar/rod.

10 In an aspect of an embodiment of the present invention, the edge of a bag near the free hanging part of the parallel bars may be kept in position firmly, by being held in/by any one of a recessed area, slot, indentation, cutout, narrowing in the bars/rods themselves or in an material that covers the bar. This configuration prevents the bag from falling off the bars or collapsing inward. The recessed area, slot, indentation, cutout, narrowing in the bars/rods that catches the edge of the bag can be made on the top, left or right sides, or bottom of bars/rods and also the front edge of the bar.

In an aspect of an embodiment of the present invention, the edge of the bag near the free hanging part of the parallel bars may be kept in position while being held by one or more protruding pieces on the bars themselves so the bag will not fall off the bars or collapse inward. The protruding pieces may have any shape or size and may be located on the top side, left or right sides, the bottom side, or the front edge of the bars. The protruding pieces may be attachable or molded into the bars and they may depress for easy loading of the bags if desired.

25 In an aspect of an embodiment of the present invention, the bars may be affixed to a cross bar or rod which is attached to sides of the compartment.

In an aspect of an embodiment of the present invention, the trash receptacle may further include an adjustable base located within the compartment where the adjustable base may be adjusted for different heights within the compartment. The adjustable base may be lowered to enable trash to sink down for easy bag removal

off the bars. The movement of the trash downward also allows easy closure of the bag, less spilling of trash, etc. In another aspect, the adjustable base may be structurally configured to lower itself with the weight of the contents within the bag.

- 5 In an aspect of an embodiment of the present invention, the bars of the trash receptacle are detachable.

In an aspect of an embodiment of the present invention, the bars of the trash receptacle may have a slight concave curve between the affixed end of each bar or rod and the free end of each bar. This configuration enables an installed bag to
10 hang easily between each ends of the bars, and prevents the installed bag from slipping off the bars

Another aspect of an embodiment of the present invention contemplates a trash receptacle which may include a compartment enclosed by walls of the trash receptacle, where the compartment may be configured to receive trash, an
15 independent frame assembly which may be releasably secured within the compartment, where the independent frame assembly may be structurally configured to releasably receive two parallel and planar horizontal bars. In one aspect, these bars or rods may be structurally configured to receive and dispense garbage bags. The receptacle may also include a lid over the compartment, the lid
20 providing access into the compartment.

Another aspect of an embodiment of the present invention contemplates a trash receptacle which may include a compartment enclosed by walls of the trash receptacle, where the compartment may be configured to receive trash, an
independent frame assembly which may be releasably secured within the
25 compartment, two parallel and planar horizontal bars, which may be affixed to the independent frame assembly, where the bars or rods are structurally configured to receive and dispense garbage bags and a lid over the compartment, the lid providing access into the compartment.

In another aspect of an embodiment of the present invention, the bars of the trash receptacle may be releasably affixed to the independent frame assembly.

In another aspect of an embodiment of the present invention, the independent frame assembly may include a base having any one of: a track, sliding mechanism
5 or wheels for sliding the independent frame assembly out of the compartment.

In another aspect of an embodiment of the present invention, the bars of the trash receptacle may include a clip mechanism at each free non-affixed end of each bar, where each clip mechanism is configured to receive the edge of an installed bag and functions to help detach the bag and where the clip mechanism prevents the
10 installed bag from sliding off the bars.

In another aspect of an embodiment of the present invention, the independent frame assembly may be placed within a general home/office cabinet to create a receptacle.

In another aspect of an embodiment of the present invention, the bars of the trash
15 receptacle may be slightly curved between an affixed end of each bar or rod and a free end of each bar.

In another aspect of an embodiment of the present invention, one end of each bar or rod may be secured to the independent frame assembly and each other end of each bar or rod may be free hanging – which, in one aspect, enables installation of
20 garbage bags by way of the free hanging ends of the bars.

In another aspect of an embodiment of the present invention, the independent frame assembly may be a vertical piece that may be releasably secured to the base of the compartment.

In another aspect of an embodiment of the present invention, access to the
25 compartment for installing garbage bags may be made possible by way of any one of a front door, side door or the lid.

In another aspect of an embodiment of the present invention, the bars or rods may be on a track/rail system of the independent frame assembly where the track/rail

system enables the bars or rods for motion in any one of the following directions within, and in relation to, the compartment: up, down, side to side or front to back.

A further aspect of an embodiment of the present invention contemplates a trash receptacle having a floor/base that can be elevated and stable while in use and when the bag is full it can be lowered by any means (pedal pushing, using your foot to depress it, etc) then as the full bag is lowered the trash will sink down into the extra bag material that usually unfolds from the bottom of the bag at that time so there is more room to tie the top. This way the trash will not overflow while being removed from the bars and the bag material at the top will now be long enough to be tied.

A further aspect of an embodiment of the present invention contemplates a bag dispensing apparatus, which may include a horizontal cross bar, pair(s) of co-planar bars perpendicularly affixed to the horizontal cross bar, where each pair(s) of co-planar bars may be configured to receive and dispense bag(s), and an attachment structure, coupled to the horizontal cross bar or rod where the attachment structure may be configured to attach the apparatus to a desired location.

In a further aspect of an embodiment of the present invention, the bag dispensing apparatus may also include a lid, configured to be positioned over a bag hung by the pair(s) of co-planar bars.

In a further aspect of an embodiment of the present invention, the bag dispensing apparatus may also include a clip mechanism at each free non-affixed end of each bar or rod of each pair(s) of co-planar bars. In one aspect, each clip mechanism may be configured to receive the edge of the bag. The clip mechanism also functions to help detach the bag and prevents the installed bag from sliding off the bars.

In a further aspect of an embodiment of the present invention, the attachment mechanism/structure may be any one of: magnets, bolts, clip on, tie downs, welding, adhesives, hook and loop, screws, glue, twist on apparatus, threading,

molding, hooks, suction device, snap on configuration, pinning, snap ring, nailing, hanging, pop in device.

In a further aspect of an embodiment of the present invention, the horizontal cross bar or rod may be collapsible. This enables the apparatus to be portable.

5 In a further aspect of an embodiment of the present invention, the apparatus may also include a drip pan, which may be positioned at the base of the bag.

In a further aspect of an embodiment of the present invention, the bag dispensing device may be placed within a general home/office cabinet to create a receptacle.

In a further aspect of an embodiment of the present invention, there is provided a trash receptacle
10 comprising:

a compartment enclosed by walls of the trash receptacle, wherein the compartment is configured to receive trash;

at least two parallel and planar horizontal bars within the compartment, wherein the bars are structurally configured to receive and dispense garbage bags; and

15 a clip mechanism located near a free non-affixed end of each bar and located parallel to the bars, wherein each clip mechanism is configured to receive a bag so that the bag is pinched by the clip mechanism and functions to prevent the bag from sliding off the bars or from collapsing inward.

In a further aspect of the an embodiment of the present invention, there is provided a trash
20 receptacle comprising:

an independent frame assembly;

at least two parallel and planar horizontal bars, affixed to the independent frame assembly, wherein the bars are structurally configured to receive and dispense bags; and

25 a clip mechanism located near a free non-affixed end of each bar and located parallel to the bars, wherein each clip mechanism is configured to receive a bag so that the bag is pinched by the clip mechanism and functions to prevent the bag from sliding off the bars or from collapsing inward.

In a further aspect of the an embodiment of the present invention, there is provided a bag dispensing apparatus, comprising:

a horizontal cross bar;

at least a pair of co-planar bars perpendicularly affixed to the horizontal cross bar,
5 wherein each at least pair of co-planar bars are configured to receive and dispense at least one bag;

an attachment structure, coupled to the horizontal cross bar wherein the attachment structure is configured to attach the apparatus to a desired location; and

a clip mechanism located near a free non-affixed end of each co-planar bar and located
10 parallel to the co-planar bars, wherein each clip mechanism is configured to receive a bag so that the bag is pinched by the clip mechanism and functions to prevent the bag from sliding off the co-planar bars or from collapsing inward.

Additional aspects, objectives, features and advantages of the present invention will become
apparent from the following description of the preferred embodiments with reference to the
15 attached drawings.

BRIEF DESCRIPTION OF THE DRAWINGS

FIG. 1 illustrates a view showing the receptacle with its lid and front door closed according to an aspect of an embodiment of the present invention.

FIG. 2 illustrates a view showing the receptacle with a lifted lid, and bars or rods that hold the
20 trash bags, according to an aspect of an embodiment of the present invention.

FIG. 3 illustrates a view showing the receptacle with a closed lid, and a front door open to reveal the hidden bars or rods according to an aspect of an embodiment of the present invention.

FIG 4. illustrates a view showing the receptacle with a lifted lid and showing how the receptacle would look without its sides and front door according to an aspect of an embodiment of the
25 present invention.

FIG. 5 illustrates a view showing the receptacle with a lifted lid and showing how the receptacle would look with the trash bags stacked in place without the

receptacle's walls and front door according to an aspect of an embodiment of the present invention.

FIG. 6 illustrates a view showing a trash receptacle having a first bag in the fully open position ready to receive trash and showing the receptacle with its lid lifted up and how the receptacle would look without the receptacle sides and front door according to an aspect of an embodiment of the present invention.

FIG.7A illustrates a trash receptacle having rods of the receptacle being attached to a cross bar that connects on the side walls with no contact to the rear wall, according to an aspect of an embodiment of the present invention.

10 FIG. 7B illustrates a trash receptacle having rods of the receptacle being independently connected directly to only the side walls of the receptacle according to an aspect of an embodiment of the present invention.

FIG. 8A illustrates a trash receptacle having rods of the receptacle being attached to a vertical bar that connects to the floor/base inside the receptacle according to an aspect of an embodiment of the present invention.

FIG. 8B illustrates a trash receptacle having rods of the receptacle on an independent trash rack/stand that can be placed inside a receptacle to provide an enclosure for it according to an aspect of an embodiment of the present invention.

FIG. 9 illustrates a side view of a trash receptacle having two straight parallel rods attached at the ceiling or lid of the receptacle according to an aspect of an embodiment of the present invention.

FIG. 10 illustrates a trash receptacle having rods attached to the receptacle door which can open with a hinge or slide out mechanism according to an aspect of an embodiment of the present invention.

25 FIG. 11 illustrates an independent frame assembly/rack/stand having an adjustable two straight parallel bar stand with a track that can move up and down and side to side, the bars can move in any direction, stand can have extra holes to move the bar if desired according to an aspect of an embodiment of the present invention.

FIG. 12 illustrates a trash receptacle having independent rack/stand within the receptacle to create an enclosed two straight rod bag holding system according to an aspect of an embodiment of the present invention.

5 FIG. 13 illustrates a trash receptacle having two bar bag hanging rod rack/system/stand with a lid/top to create the enclosure of the bag according to an aspect of an embodiment of the present invention.

FIG. 14A illustrates a trash receptacle having multiple sets of two or more rods within a receptacle or cabinet allowing multiple bags to each hang on a two rod system for various purposes such as recycling, trash, and compost all in one
10 location according to an aspect of an embodiment of the present invention.

FIG. 14B illustrates a trash receptacle with optional lid(s) and having multiple sets of two or more rods within a receptacle or cabinet allowing multiple bags to each hang on a two rod system for various purposes such as recycling, trash, and compost all in one location according to an aspect of an embodiment of the
15 present invention.

FIG. 15 illustrates a trash receptacle having a parallel bar hanger device/system according to an aspect of an embodiment of the present invention.

FIG.16 illustrates a receptacle with a height adjustable base/floor according to an aspect of an embodiment of the present invention.

20 FIG. 17 illustrates a receptacle with an adjustable base that is in the depressed or lowered position according to an aspect of an embodiment of the present invention.

FIG. 18 illustrate a home, office, or work cabinet configured to become the receptacle according to an aspect of an embodiment of the present invention.

25 FIG. 19A illustrates a trash receptacle having two straight parallel bag holding bar device on a tree with a strap band to secure it around the tree according to an aspect of an embodiment of the present invention.

FIG. 19B illustrates a trash receptacle having two straight parallel bag holding bar device on a table secured with a clamp according to an aspect of an embodiment of the present invention.

5 FIG. 19C illustrates a trash receptacle having two straight parallel bag holding bar device on a large vehicle secured with a magnet according to an aspect of an embodiment of the present invention.

FIG. 19D illustrates a trash receptacle having two straight parallel bag holding bar device being used with multiple bar and bag option secured to a fence according to an aspect of an embodiment of the present invention.

10 FIG. 20A illustrates a clip mechanism used on the receptacle's bars or rods according to an aspect of an embodiment of the present invention.

FIG. 20B illustrates a clip mechanism used on the receptacle's bars or rods and in operation with a trash bag according to an aspect of an embodiment of the present invention.

15

DETAILED DESCRIPTION OF THE INVENTION

In a certain aspect of an embodiment of the present invention, the trash receptacle or trash can (terms "can", "trash can", "receptacle", "trash receptacle" being used interchangeably throughout this disclosure) be particularly made for trash bags that have holes punched in them that they hang by. The bags hang, move and
20 function simply by hanging on two preferably straight parallel bars/poles/sticks that can be made from any material. In one aspect of an embodiment of the present invention, the bars or rods may have minor curves. These parallel bars or rods may connect to one side of the wall in the trash receptacle and do not need to connect to anything for support at the sides or the end where the bag slides off.
25 They basically connect for support to one wall and free hang straight out. The bars or rods are enclosed within the trash can/receptacle and may run from the back area of the receptacle horizontally towards the front area of the receptacle.

In one aspect, the bars, while usually being parallel, could be offset bars or rods and can be of any length, thickness or made out of any material. Additional aspects of embodiments of the present invention contemplate the bars or rods having a variety of textures and/or features that will enable trash bags to be smoothly installed/removed and/or prevent the bags from falling off the front of the bars or rods while the bags are in a “ready to use” position. For instance, the ends of the bars or rods may have a rubber texture which may grip the bag and prevent it from slipping off.

The trash receptacle, as contemplated in one aspect, is made to be enclosed with access being provided in a number of ways via including a front door, side door or any way desired to provide access to the trash bags for their loading and unloading. The can/receptacle may also be made of any material and be of any size, color and/or shape having a lid. The can/receptacle may be adapted for use in numerous settings including household, industrial, commercial fast food, within cabinets etc.

Aspects of embodiments of the present invention are distinguished from other trash cans/receptacles or stands which use bags which are clipped into position, or are “wrapped” around a rim of any shape whether circular or square etc. or made to use with grocery store “handled bags” aka t-shirt bags will not work in the trash can/receptacle contemplated in the present invention. In contrast, the contemplated invention enables loading of the bags onto the bars or rods by way of holes/openings in them. The bags do not wrap around or over the bars or rods but rather slide onto the bars or rods and hang on them. The bags may be able to move into a ready-to-use, open position by moving the bag along the bars or rods from the rear area of the trash can/receptacle towards the front middle area of the can/receptacle while they unfold or expand so they are ready to receive waste/trash. When the bags are full, they may be pulled off the bar or rod by sliding them towards the front of the receptacle until they fall off the bars. The next bag usually will be pulled towards the front from the rear area as it begins to open for use.

One aspect of an embodiment of the present invention contemplates an enclosed trash can/receptacle that can have a lid. It can have different style doors but will have some sort of opening to access the bag and allow it to be pulled horizontally off the bars or rods to allow the next bag on. This configuration is distinct from the prior art as any type of stand cannot function the same way because prior art cans/receptacles expose the bag of trash out in the open and do not keep the trash enclosed for sanitary or esthetic reasons.

The bars or rods can be installed/secured to the can/receptacle in a number of ways, including, but not limited to, any wall of the receptacle, the roof of the receptacle, the lid of the receptacle, the floor/base of the receptacle, the frame of the receptacle, door of the receptacle. In one aspect, the bars or rods may be attached or secured to a separate piece which in turn may be attached to the receptacle by being mounted or bracketed to the receptacle. Such a piece may be vertical in structure/alignment and may have the bars or rods secured to it at a right angle. In another aspect, the bars or rods may be installed on a track/rail system that would enable motion in an up, down or sideways direction. Methods of securing/attaching the bars or rods may include, but not be limited to, welding, using: adhesives, hook and loop, screws, bolts, glue, magnets, clips, twist on apparatus(es), threading, molding, hooks, suction device(s), snap on configuration(s), pinning, snap ring mounting, nailing, pop in configuration(s), hanging, etc.

In configurations where the receptacle has a side access door, the bars or rods may be installed to run horizontally from one side towards the other side of the receptacle as opposed to the back to front direction as previously discussed.

In sum, an aspect of an embodiment of the present invention contemplates an enclosed trash can for privacy/hiding of a trash bag with two internal parallel free floating (attached at one end) horizontal bars or rods that are made for trash bags that have holes in them so they can free hang on those parallel bars or rods for use and removal.

Advantages of the present invention include:

- Having trash bags readily available for use following removal of a previous bag.
- Increased trash bag changing speed
- Enabling use of bags that have holes in them to hang them by
- 5 • Increased privacy
- More efficient/effective odor control
- Elimination of the time it takes to hang bags on clips or fold/secure onto rims
- Being specially designed to handle the specially designed bags that hang
- 10 on bars or rods despite having an outward normal trash can/receptacle appearance.
- Enabling the loading of a large quantity of trash bags that may be in a stack/package and are enabled to be dispensed one after another.
- Enabling the removal of a full bag horizontally off the bars or rods which
- 15 eliminates the need to vertically lift a full bag out of the can/receptacle.

Optional aspects of embodiments of the present invention contemplate having the can and rods sold separately or together. Other aspects contemplate the trash can/receptacle presented as one piece where the bars or rods are already molded into place. Additional aspects contemplate retrofit configurations – i.e. where

20 existing cans/receptacles may be retrofitted to include the aforementioned bars. Further aspects contemplate including a drip tray/pan at the base of the can/receptacle to catch any fluid that may leak from the bags. For additional support, when and where needed, additional rods or bars or rods may also be included.

25 Referring now to FIG. 1 a trash receptacle 1 is shown according to an aspect of an embodiment of the present invention. Trash receptacle 1 may have a lid 2 for covering the bag within the receptacle. In one aspect of an embodiment of the present invention, receptacle 1 may also include a door 3 for providing access into receptacle 1 in order to install or remove full trash bags.

Referring now to FIG. 2 receptacle 1 is shown with its lid 2 being lifted up to reveal interior hidden bars or rods 5 that hold the trash bags within compartment 4 of receptacle 1, according to an aspect of an embodiment of the present invention. Receptacle 1 may have two “straight” parallel bars or rods 5 inside an enclosed
5 receptacle/cabinet 1 that can be used by connecting them various ways in addition to the rear wall of receptacle 1.

Referring now to FIG. 3 receptacle 1 is shown with its lid 2 closed and its front door 3 open to reveal hidden bars or rods 5 according to an aspect of an embodiment of the present invention.

10 Referring now to FIG. 4 receptacle 1 is shown with lid 2, bars or rods 5 and compartment 4 according to an aspect of an embodiment of the present invention.

Referring now to FIG. 5 receptacle 1 is shown with lid 2 lifted up and with a folded stack of trash bags 6 in place without the receptacle’s walls (for emphasis) and front door according to an aspect of an embodiment of the present invention.

15 Referring now to FIG. 6 receptacle 1 is shown with a first bag 7 in the fully open position ready to receive trash and showing receptacle 1 with lid 2 lifted up according to an aspect of an embodiment of the present invention.

Aspects of embodiments of the present invention contemplate straight parallel bars or rods 5 that can free hang on one side, are long enough to allow a large
20 quantity of bags 6 to load and remain supported while expanding across receptacle 1. Certain aspects of embodiments of the present invention also contemplate bars or rods 5 that are smooth enough for a bag 7 with holes to slide from the loaded position into the ready to use position and then off the free hang portion to exit the bar or rod 5 when full. Bars or rods 5 do not require a user to load on one bag at a
25 time by wrapping it around the top like a ring or rim. They also do not require a user to clip each side into position, or hang the bag by its handles if applicable. Bars or rods 5 are located towards the top area of receptacle 1 to facilitate the bag to hang by its holes and extend down into receptacle 1’s compartment 4 where it fills up with trash or items. In an aspect of an embodiment of the present invention

bars or rods 5, may have simple minor curves to ease loading and help keep bag 7 or bags 6 on, but do not have any curves that interfere with the utility function of easy loading and snag free deployment.

Certain aspects of embodiments of the present invention, when used in the commercial setting and even household kitchens, may require bags that are much larger and thicker than grocery store bags. Bags with a thick enough gauge to hold in fluid and shaper items are difficult to fold and keep in a tight position. These bags must be able to stay close to the bar or rod which means a smaller diameter hole in them to hang on the bar or rod with. The bags must be able to expand long enough to accommodate a large amount of trash and also have room at the top to tie closed. A firm package must be used to keep small holes in alignment to load onto bars. Firm boxes and packages do not allow much flexibility and do not work with strong curves or “b” shaped pins/rods. Packaging must be long enough to hold a large bag but short enough to not allow the new bags to be soiled by touching the bottom area of the current used bag which can leak. In order to keep large trash bags folded and tight a package is needed versus just a stack of individual bags at the rear area of a rack. It is not practical to use loose bags without firm large packages; the bags are not orderly and unfold inconveniently. Aspects of embodiments of the present invention address the specifics of using rods inside a receptacle that can handle the type of movement and packaging needed to use very large bags in order to create a useful product. Bars or rods 5 have the ability to offer various features, rubber or other gripping material on the bars or rods to keep bag from sliding, a low profile clip mechanism to maintain bag position once it is deployed so it cannot accidentally close while in use etc. Such features allow the speed of the bag to be controlled and can allow the bag to hold its position very well while in use.

In aspects of embodiments of the present invention, the bars or rods 5 may be straight at their connection point with receptacle 1 and at the free hang ends. Bars or rods 5 allow loading of a firm tall package or even box that can hold very large bags that are preferably folded up from the bottom and bags that also have small holes for their installation) so they stay close to the bar or rod to avoid sagging.

Sagging allows a gap between the bar or rod and the sides of the bag which allows items to land outside of the bag. Other aspects contemplate bars or rods or rods that are slightly curved between their connection point and their free ends. This configuration enables securing a bag in place by preventing it from slipping of the
5 pair of bars or rods or rods.

With small holes that fit well to the poles there is a problem with “b” shaped pins, as disclosed in some prior art, since one cannot maneuver a large, tall, thick, firm pack or box of bags onto the loading end of a “b” shaped pin, there isn’t enough clearance from the back wall of the receptacle to maneuver the package past the
10 large curve that leads the package upward to get it onto the straight part of the bar. The second problem with the “b” shape pin is that the area the package sits along the rear wall can get stuck in that curve. It is also difficult for the next bag to get over that curve in order to have a smooth deployment. These details are important especially since the type of bag the present invention will use will make the bag
15 depend on the first used bag to successfully pull the second bag smoothly into the ready to use position, without the user having to touch the second bag. These types of bags preferably are connected to each other and that is how they can pull each other into place.

Referring now to FIG.7A trash receptacle 1 is shown having bars or rods 5 of
20 receptacle 1 being attached to a cross bar that connects with receptacle 1’s the side walls according to an aspect of an embodiment of the present invention. In this aspect, bars or rods 5 do not connect with receptacle 1’s rear wall.

Aspects of embodiments of the present invention contemplate bars or rods 5 being attached to different parts of receptacle 1 including lid 2, walls of receptacle 1,
25 base/floor of receptacle 1, and door 3 which can slide out or be on a hinge. Bars or rods 5 may be on a track that can be installed on the back wall of receptacle 1 or as used on an independent item such as a hanging mechanism. In another aspect, the user can have a bag stand that will fit into the receptacle to create an “enclosed” system by combining the two products. Some of these aspects may be
30 seen in FIGs. 7B through FIG. 10. In one aspect of an embodiment of the present

invention, the stand may be collapsible or foldable for easy storage or transport if desired.

FIG. 7B illustrates another aspect of an embodiment of trash receptacle 1 having bars or rods 5 being independently connected directly to only the side walls of receptacle 1.

Referring now to FIG. 8A trash receptacle 1 is shown with bars or rods 5 being attached to a vertical frame that connects to the floor/base inside receptacle 1 according to an aspect of an embodiment of the present invention.

Referring now to FIG. 8B bars or rods 5 of receptacle 1 are shown as part of an independent trash rack/stand that can be placed inside a receptacle according to an aspect of an embodiment of the present invention.

Referring now to FIG. 9, a side view of trash receptacle 1 is shown with two straight parallel rods 5 attached at ceiling or lid 2 of receptacle 1 according to an aspect of an embodiment of the present invention.

Another placement configuration for bars or rods 5 may be seen in FIG. 10 where bars or rods 5 are attached to receptacle door 3 which can open with a hinge or slide out mechanism according to an aspect of an embodiment of the present invention.

Referring now to FIG. 11 trash receptacle 1 may be seen having an adjustable two straight parallel bar stand 9 that has a track 10 that can move up and down and side to side by any means, according to an aspect of an embodiment of the present invention. Bars or rods 5, being connected or affixed to slots within track 10, can move in any direction, the width between the bars or rods may be widened by placing each respective bar in a different slot or extra holes of track 10 and the height may also be adjusted by either lowering or elevating track 10.

FIGs. 12 and 13 illustrate trash receptacle 1 having independent rack/stand 8 within receptacle 1 to create an enclosed bag holding system according to an aspect of an embodiment of the present invention. In one aspect of an embodiment

of the present invention, a lid 2 may also be hingedly coupled or connected with frame 8 to cover any trash bags that may be installed. Bars or rods 5 may be directly connected or affixed to frame 8 which may also have a base with a sliding mechanism or wheels to enable frame 8 to slide or be wheeled out of receptacle 1.

5 Aspects of embodiments of the present invention contemplate pairs of bars or rods 5 being used within one compartment as shown in FIGS. 14A and 14B. These applications enable multiple bags 7 to each hang on each pair of bars or rods 5 for various purposes such as recycling, trash, and compost all in one location according to an aspect of an embodiment of the present invention.

10 Another aspect of an embodiment of the present invention contemplates bars or rods 5 being part of a parallel bar hanger device/system according to an aspect of an embodiment of the present invention and as shown in FIG. 15. Here, the parallel bar hanger device/system may be detachable and may be used in conjunction with existing receptacles.

15 Another aspect of an embodiment of the present invention contemplates a height adjustable base/floor 15 within receptacle 1 as shown in FIGS. 16 and 17. Base/floor 15 may be elevated while in use. When the bag is full it can be lowered by a number of ways including pedal pushing, using your foot to depress it, etc. As base/floor 15 is lowered, the trash will then be able to sink down into the extra
20 bag material that usually unfolds from the bottom of the bag at that time so there is more room to tie the top. This way the trash will not overflow while being removed from the bars and the bag material at the top will now be long enough to be tied.

Referring now to FIG. 18 home, office, or work cabinet 12 configured to become
25 receptacle 1 is shown according to an aspect of an embodiment of the present invention. Cabinet(s) may be modified or made for the home or office environment in order to create an enclosed two bar or rod bag hanging system inside cabinet 12. Many kitchens for example have cabinetry made to hold a trash can that can slide open on a sliding door or drawer system. By attaching the rods 5
30 to the inside of the cabinet door 3 or inside that cabinet to any wall the user can

load two bar or rod system style bags. Under many kitchen sinks people have a small bag rack or ring attached to the inside of the door to hang bags around a rim in a circular style or hang them on special handles made for the grocery style bags to hang on. Unfortunately, they are not two parallel bars or rods long enough to use in this fashion. Bars or rods 5 can also be placed inside any type of home, office, etc. cabinet by any means including creating a special rack, frame, poles, track, etc that can be purchased by the user and set in or attached inside of the cabinet. Any two bar or rod style system used inside of cabinets for the purposes of the present invention is included. Bars or rods 5 are not just for collection within garbage containers/receptacles as mentioned in the prior art. Rather, aspects of the present invention are configured and may work for the creative purpose of being placed inside general cabinetry to provide a two bar or rod bag system for people to use in custom home, office, or work locations as the users preferred convenient way of handling trash.

Further aspects of embodiments of the present invention are shown in FIGs. 19A through 19D showing installations of two straight parallel bag holding bar device 17 in different applications. This aspect offers consumers the option to have a two straight parallel bag hanging bar or rod device 17 with an optional lid 2 that is easily transported and installed. This device will be able to use two straight parallel bars or rods that may have minor curves and may have features that allow the bag to move smoothly and stay in various positions as described. The simple device can be made and assembled for use in various ways. It can have the bars or rods fold or collapse toward the center for compact storage. It can have pieces connect together by any means or be made as one complete piece. The two straight bars or rods can be created in many ways including creating them by bending longer bars or rods into an "L" shape or 90 degree angle to use one part to attach somewhere and the other portion to use to hang the bags on. The rear area that usually makes contact with the surface it attaches to may have features that allow it to hold on to or keep the bag stack in place neatly. The device may also be able to attach, for example, to the outside of food trucks by any means or any other surface by magnets, bolts, clip on, tie downs, welding, adhesives, hook and

loop, screws, glue, twist on apparatus (es), threading, molding, hooks, suction device(s), snap on configuration, pinning, snap ring, nailing, hanging, pop in, it may be used with hinges and fold up almost flat while still attached to the surface and then unfold into the ready to use position when needed etc. For example the

5 owner can create an instant trash bag holder with lid if desired by simply attaching the device onto the outside of the truck exterior. The device can be used at a park by attaching it with a tie, clamp, or any other means to a tree. The device can also be attached to a door, end of a table with a clamp, onto an R.V. or object at a campsite, a railing or fence etc. by clipping it to the same. Device 17 can also be

10 used at a construction site to collect trash by attaching it to wood beams, vehicles, outhouses, etc. Device 17 may be used in a garage on a wall to collect recyclables. Device 17 may be used at fairs, beaches, attached to a ground stake or other means to keep it stable. Device 17 may be attached to a diaper changing table or even by magnet to the side of a fridge in small homes. Device 17 is portable,

15 small, and easy to install by any means and be readily available to meet the needs of any size crowd or event. The device can have an extension for example long hanging bars or rods that hang over the top of the door and lower the two parallel bag hanging bars or rods to the height the user prefers them at. The device may also include a lid and also a drip catch tray or pad if needed to ensure it can be

20 enclosed to keep pests out and also not drip waste onto the ground. The device can be made of any material, size, color, and sell as a set of items listed here or individually as attachments or accommodating parts. Parallel bars or rods 5 can be made as one unit staying connected or be two rods in a set that are installed individually. Device 17 may have a long horizontal bar or rod or connecting piece

25 with a few sets of bars or rods that extend out from it in order to allow multiple bags to hang from one device. Device 17 may be installed on any surface by a number of installation methods or ways.

Referring now to FIGs. 20A and 20B, a clip mechanism 18 is shown on bars or rods 5 according to an aspect of an embodiment of the present invention. Each

30 clip mechanism 18 may be located towards the free hanging end of bar or rod 5. As shown in FIG. 20B, clip mechanism captures the front end of a deployed trash

bag 7 and holds it in place thereby prevent bag 7 from slipping off bars or rods 5. Once bag 7 is full, a user may then pull trash bag 7 over clip mechanism 18 and as each bag is connected with each other, a new bag is installed in place and captured by clip mechanism 18.

- 5 The invention has been described in detail with particular reference to certain preferred embodiments thereof, but it will be understood that variations and modifications can be effected within the spirit and scope of the invention.

What is claimed is:

1. A trash receptacle comprising:
 - a compartment enclosed by walls of the trash receptacle, wherein the compartment is configured to receive trash;
 - at least two parallel and planar horizontal bars within the compartment, wherein the bars are structurally configured to receive and dispense garbage bags;
 - and
 - a clip mechanism located near a free non-affixed end of each bar and located parallel to the bars, wherein each clip mechanism is configured to receive a bag so that the bag is pinched by the clip mechanism and functions to prevent the bag from sliding off the bars or from collapsing inward.
2. The trash receptacle of claim 1 wherein one end of each bar is secured to an inside wall of the compartment and wherein each other end of each bar is free hanging.
3. The trash receptacle of claim 1 wherein access to the compartment for installing garbage bags is made possible by way of any one of a front door, side door or a lid.
4. The trash receptacle of claim 1 wherein the bars are structurally configured to hold garbage bags in a stack.
5. The trash receptacle of claim 1 wherein the bars are structurally configured to receive and dispense garbage bags with punch holes.
6. The trash receptacle of claim 1 further comprising of a drip tray/pan located at the base of the compartment.
7. The trash receptacle of claim 1 wherein the bars are secured to any one of the following: any wall of the compartment, lid of the receptacle, floor/base of the

receptacle, frame of the receptacle, door of the receptacle, ceiling of the receptacle.

8. The trash receptacle of claim 1 wherein the bars are on a track/rail system wherein the track/rail system enables the bar for motion in any one of the following directions with the compartment: up, down, side to side, or front to back.
9. The trash receptacle of claim 1 wherein the bars are affixed to a panel within the compartment.
10. The trash receptacle of claim 9 wherein the panel comprises of multiple sets of attachment positions to enable bar attachment settings at different heights.
11. The trash receptacle of claim 9 wherein the panel comprises of a track to which the bars are affixed wherein the track is able to vertically slide up or down the panel to enable different bar setting heights.
12. The trash receptacle of claim 1 further comprising a lid over the compartment, the lid providing access into the compartment.
13. The trash receptacle of claim 1 wherein the bars are affixed to a cross bar which is attached to sides of the compartment.
14. The trash receptacle of claim 1 further comprising of an adjustable base located within the compartment wherein the adjustable base is adjusted for different heights within the compartment.
15. The trash receptacle of claim 1, wherein the bars are detachable.

16. The trash receptacle of claim 1 wherein the bars are curved between an affixed end of each bar and a free end of each bar.
17. A trash receptacle comprising:
 - an independent frame assembly;
 - at least two parallel and planar horizontal bars, affixed to the independent frame assembly, wherein the bars are structurally configured to receive and dispense bags; and
 - a clip mechanism located near a free non-affixed end of each bar and located parallel to the bars, wherein each clip mechanism is configured to receive a bag so that the bag is pinched by the clip mechanism and functions to prevent the bag from sliding off the bars or from collapsing inward.
18. The trash receptacle of claim 17 wherein one end of each bar is secured to the independent frame assembly and each other end of each bar is free hanging.
19. The trash receptacle of claim 17 wherein the independent frame assembly is a vertical piece that is releasably secured to the base of the compartment.
20. The trash receptacle of claim 17 wherein the bars are releasably affixed to the independent frame assembly.
21. The trash receptacle of claim 17 wherein the independent frame assembly further comprises of a base having any one of: a track, sliding mechanism or wheels for sliding the independent frame assembly out of the compartment.
22. The trash receptacle of claim 17 further comprising a compartment enclosed by walls of the trash receptacle, wherein the compartment further comprises a lid over the compartment, the lid providing access into the compartment.

23. The trash receptacle of claim 17 wherein the bars are curved between an affixed end of each bar and a free end of each bar.
24. The trash receptacle of claim 22 wherein access to the compartment for installing garbage bags is made possible by way of any one of a front door, side door or the lid.
25. The trash receptacle of claim 17 wherein the bars are structurally configured to hold garbage bags in a stack or inside a loaded package.
26. The trash receptacle of claim 17 wherein the bars are structurally configured to receive and dispense garbage bags with punch holes.
27. The trash receptacle of claim 22 further comprising of a drip tray/pan located at the base of the compartment.
28. The trash receptacle of claim 17 wherein the receptacle is placed within a general home/office cabinet to create a receptacle.
29. The trash receptacle of claim 17 wherein the bars are on a track/rail system of the independent frame assembly wherein the track/rail system enables the bars for motion in any one of the following directions with the compartment: up, down, side to side, front to back.
30. A bag dispensing apparatus, comprising:
 - a horizontal cross bar;
 - at least a pair of co-planar bars perpendicularly affixed to the horizontal cross bar, wherein each at least pair of co-planar bars are configured to receive and dispense at least one bag;
 - an attachment structure, coupled to the horizontal cross bar wherein the

attachment structure is configured to attach the apparatus to a desired location;

and

a clip mechanism located near a free non-affixed end of each co-planar bar and located parallel to the co-planar bars, wherein each clip mechanism is configured to receive a bag so that the bag is pinched by the clip mechanism and functions to prevent the bag from sliding off the co-planar bars or from collapsing inward.

31. The bag dispensing apparatus of claim 30, further comprising a lid, configured to be positioned over a bag hung by the at least pair of co-planar bars.

32. The bag dispensing apparatus of claim 30 wherein the attachment structure is any one of: magnets, bolts, clip on, tie downs, welding, adhesives, hook and loop, screws, glue, twist on apparatus, threading, molding, hooks, suction device, snap on configuration, pinning, hanging, snap ring, nailing, pop in device.

33. The bag dispensing apparatus of claim 30 wherein the bag dispensing apparatus is collapsible.

34. The bag dispensing apparatus of claim 30 further comprising of a drip pan, which is positioned at the base of the bag.

35. The bag dispensing apparatus of claim 30 wherein the device is placed within a general home/office cabinet to create a receptacle.

36. The trash receptacle of claim 17 further comprising a lid.

37. The trash receptacle of claim 17 further comprising a drip tray.

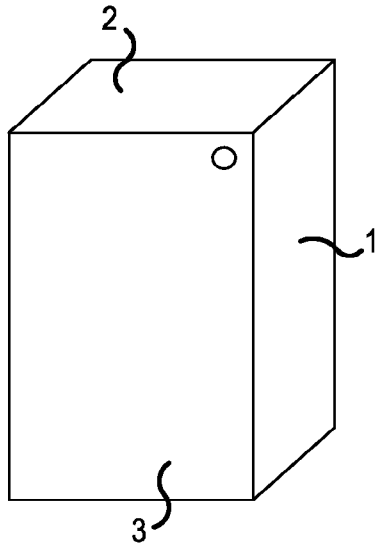

FIG. 1

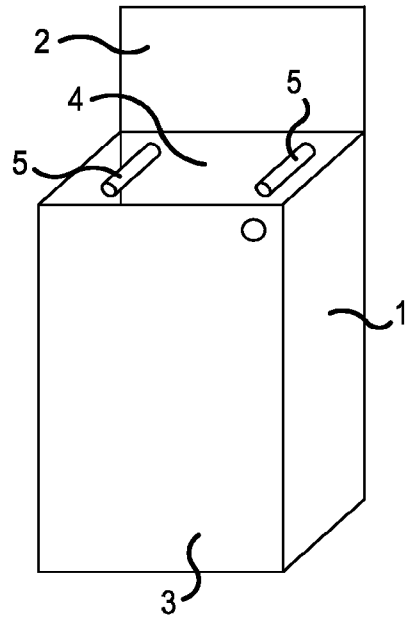

FIG. 2

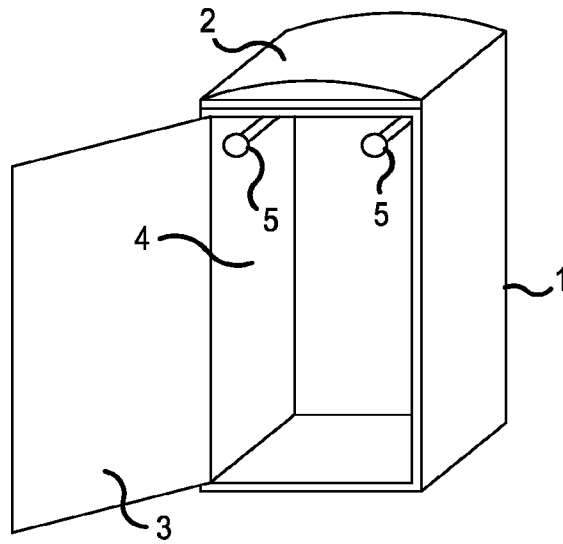

FIG. 3

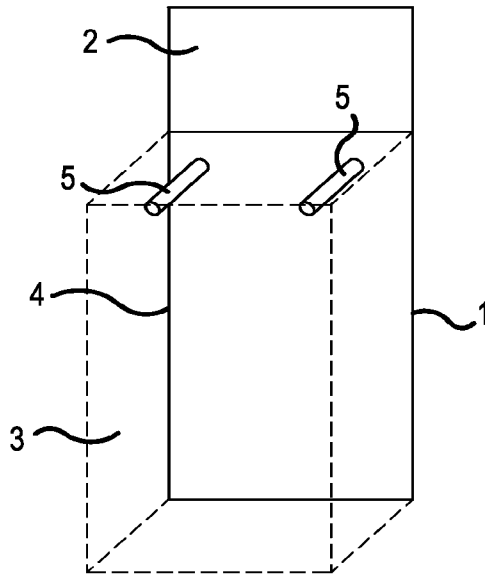

FIG. 4

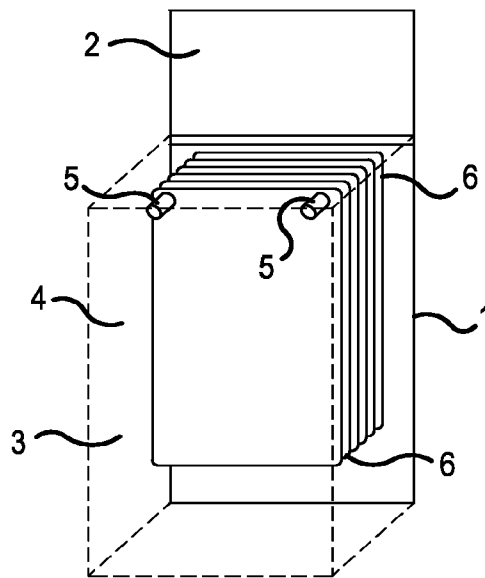

FIG. 5

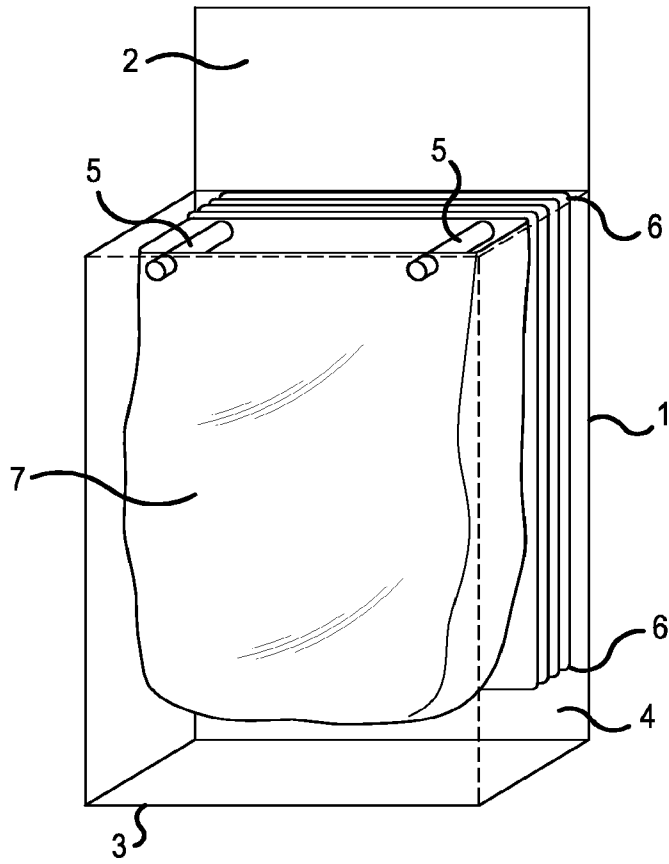

FIG.6

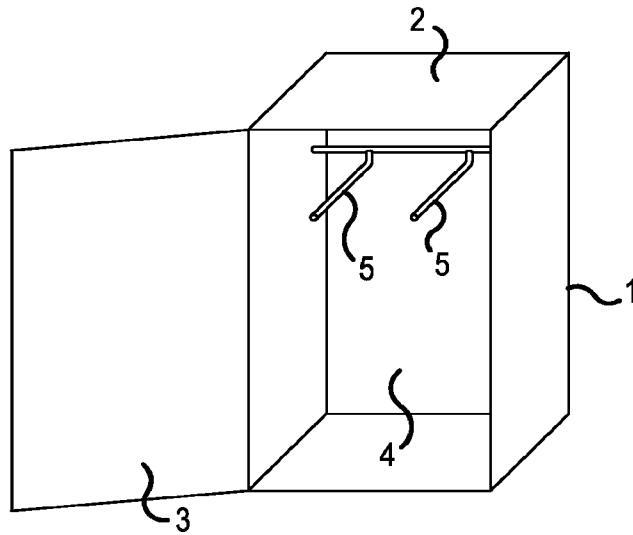

FIG. 7A

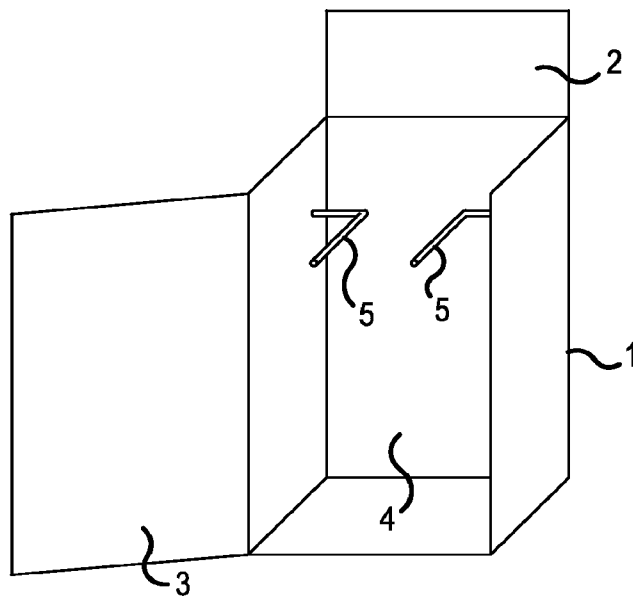

FIG. 7B

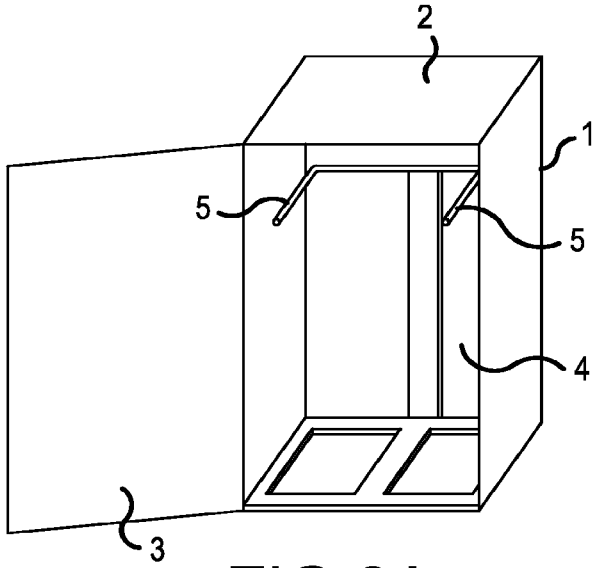

FIG. 8A

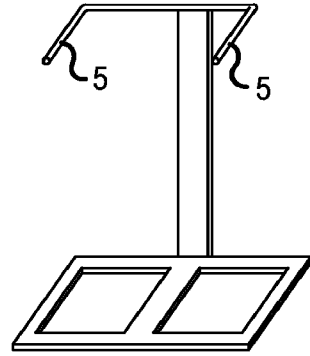

FIG. 8B

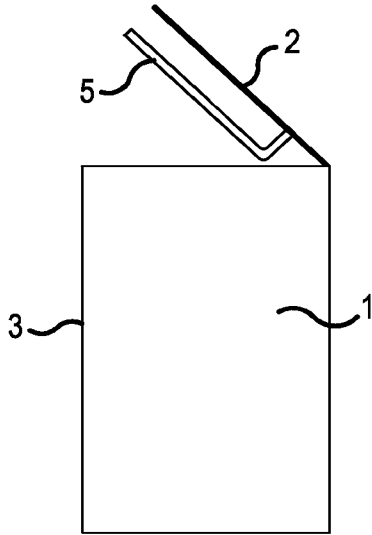

FIG. 9

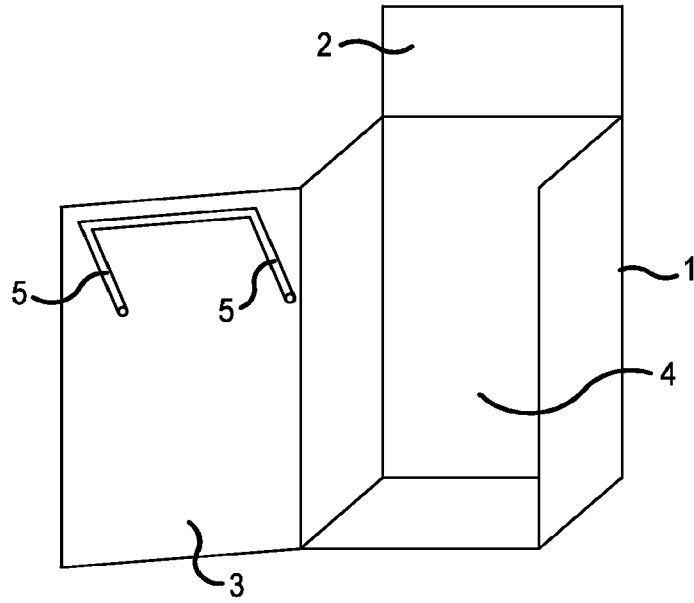

FIG. 10

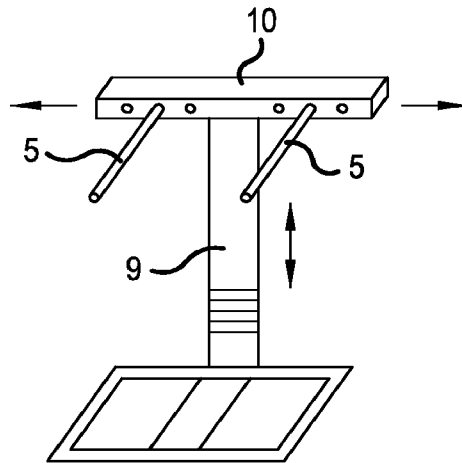

FIG. 11

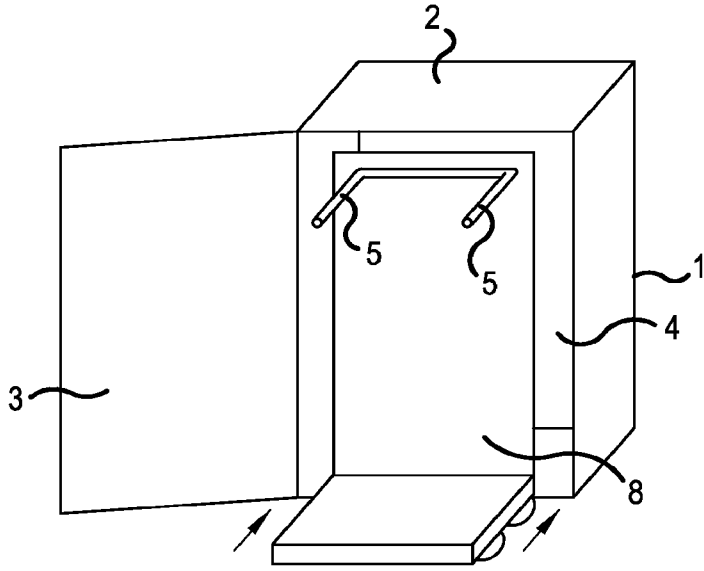

FIG. 12

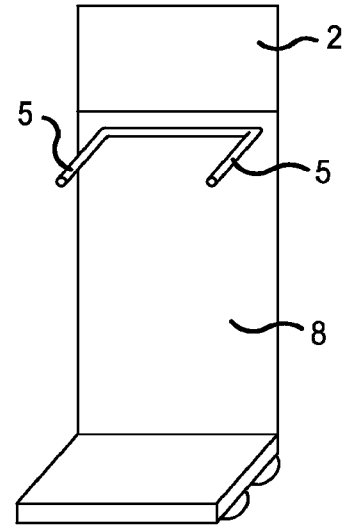

FIG. 13

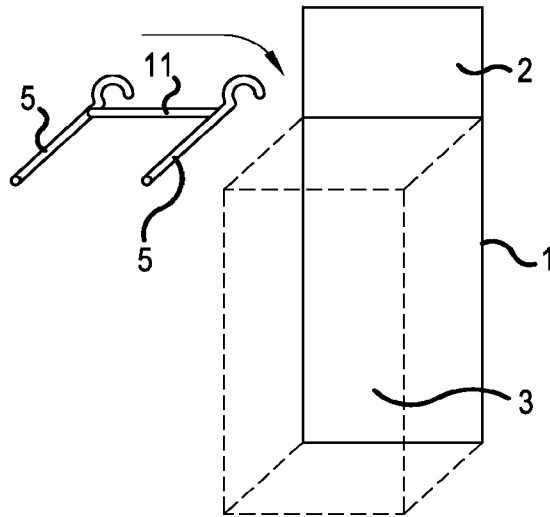

FIG. 15

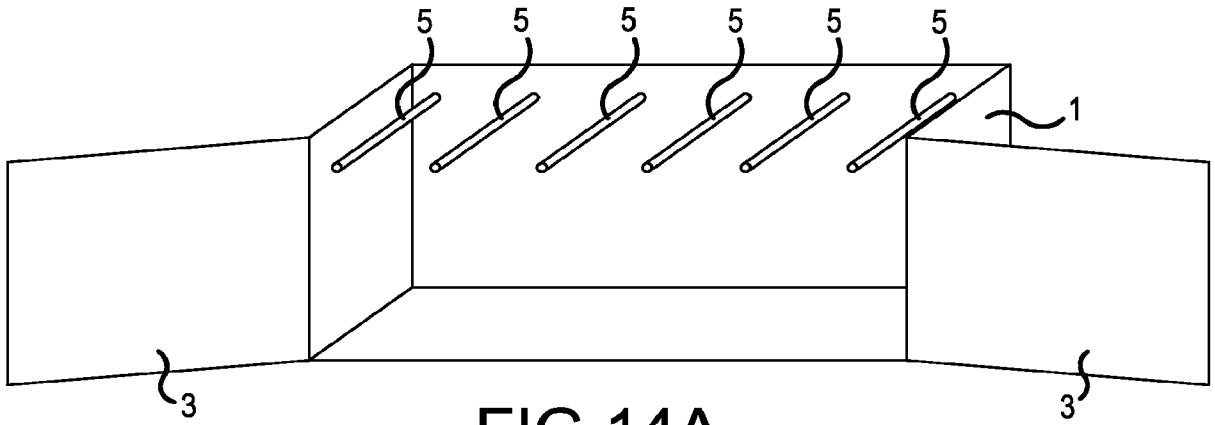

FIG. 14A

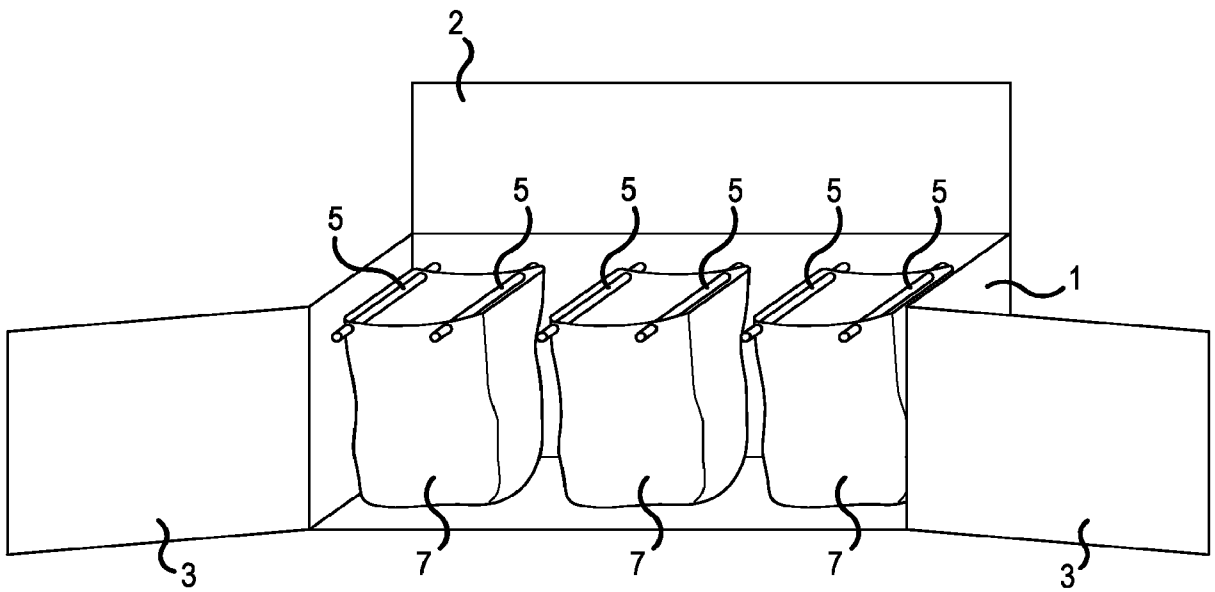

FIG. 14B

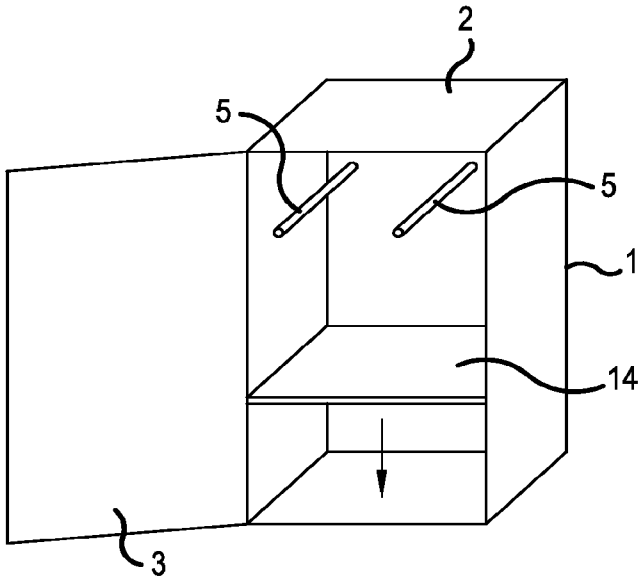

FIG. 16

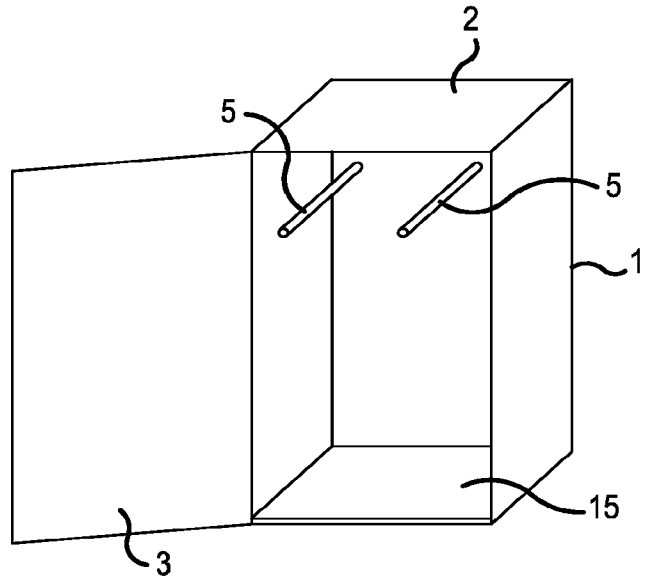

FIG. 17

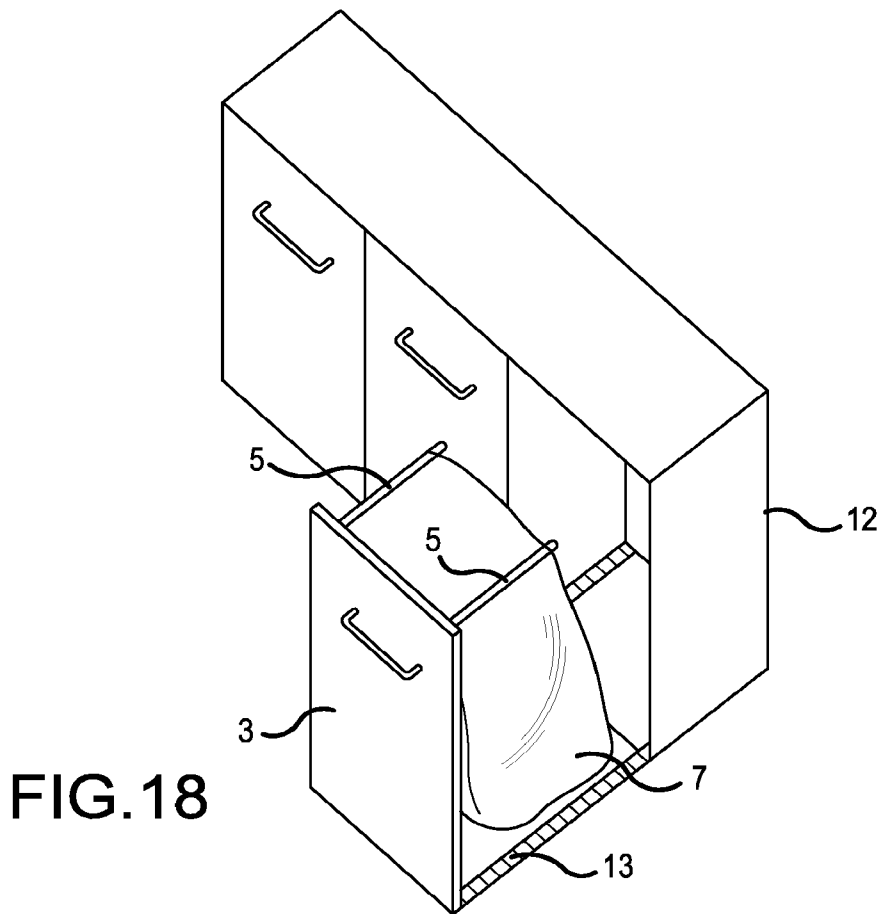

FIG. 18

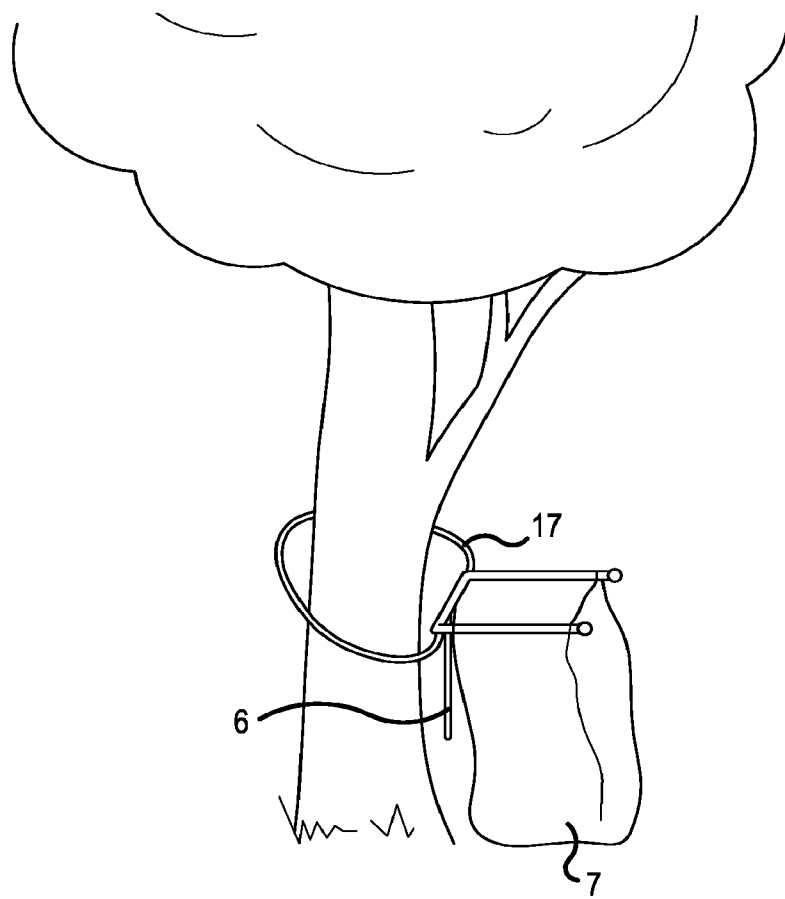

FIG. 19A

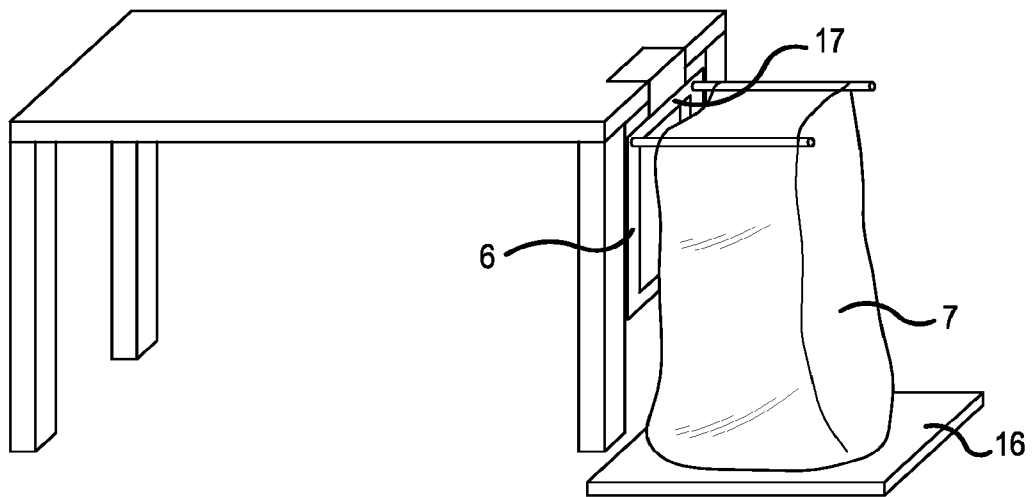

FIG. 19B

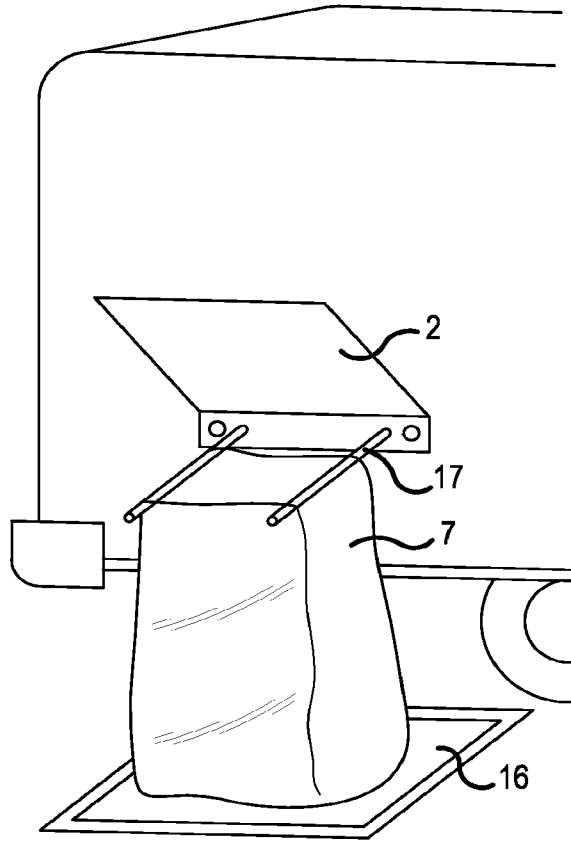

FIG. 19C

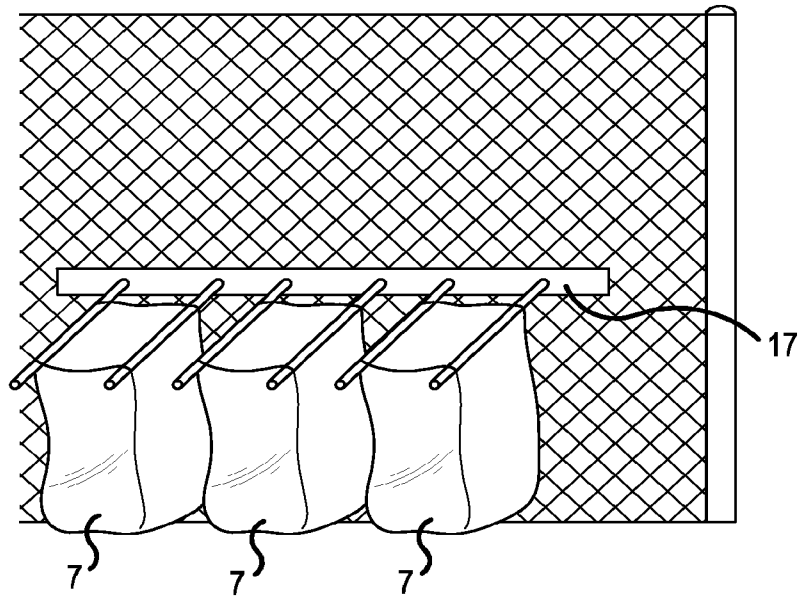

FIG. 19D

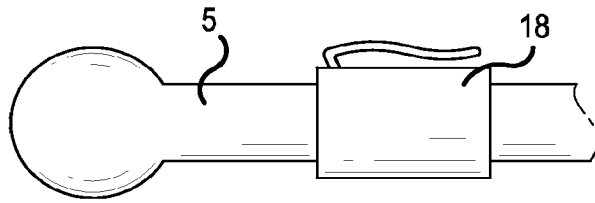

FIG. 20A

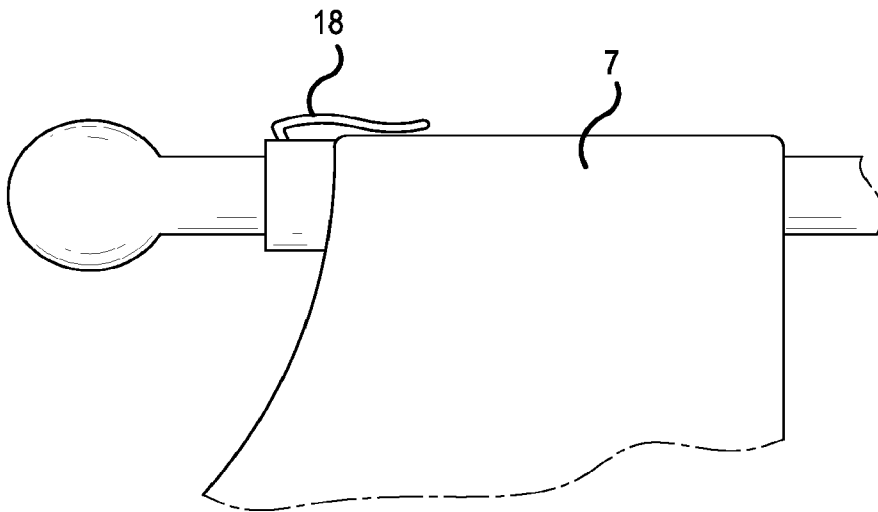

FIG. 20B

