

W. K. LEWIS.
 BEET HARVESTER.
 APPLICATION FILED AUG. 15, 1910.

Patented July 18, 1911.

998,296.

4 SHEETS-SHEET 1.

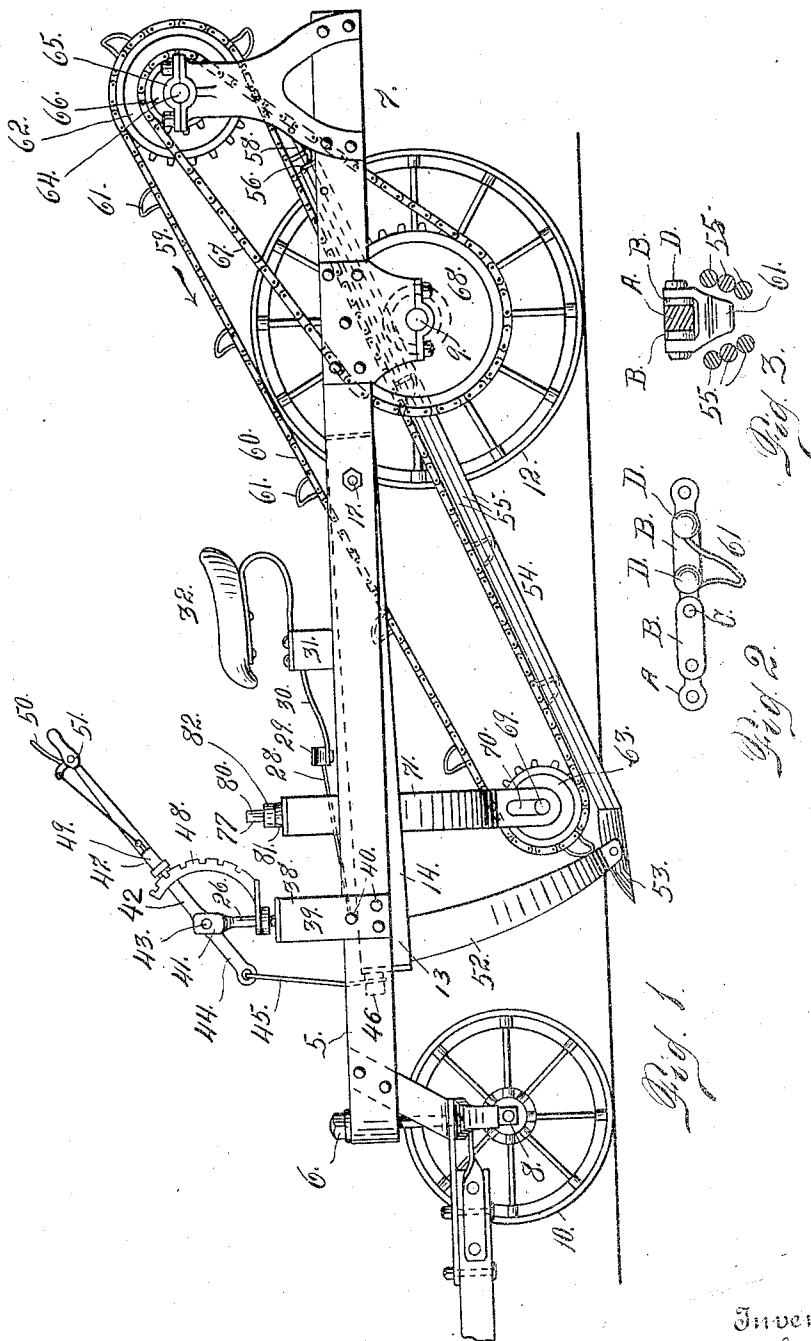

Witnesses
Otto E. Haddick.
C. H. Roessner.

Inventor
William K. Lewis.
 By *C. F. O'Brien.*
 Attorney

W. K. LEWIS.
 BEET HARVESTER.
 APPLICATION FILED AUG. 15, 1910.

Patented July 18, 1911
 4 SHEETS—SHEET 2.

998,296.

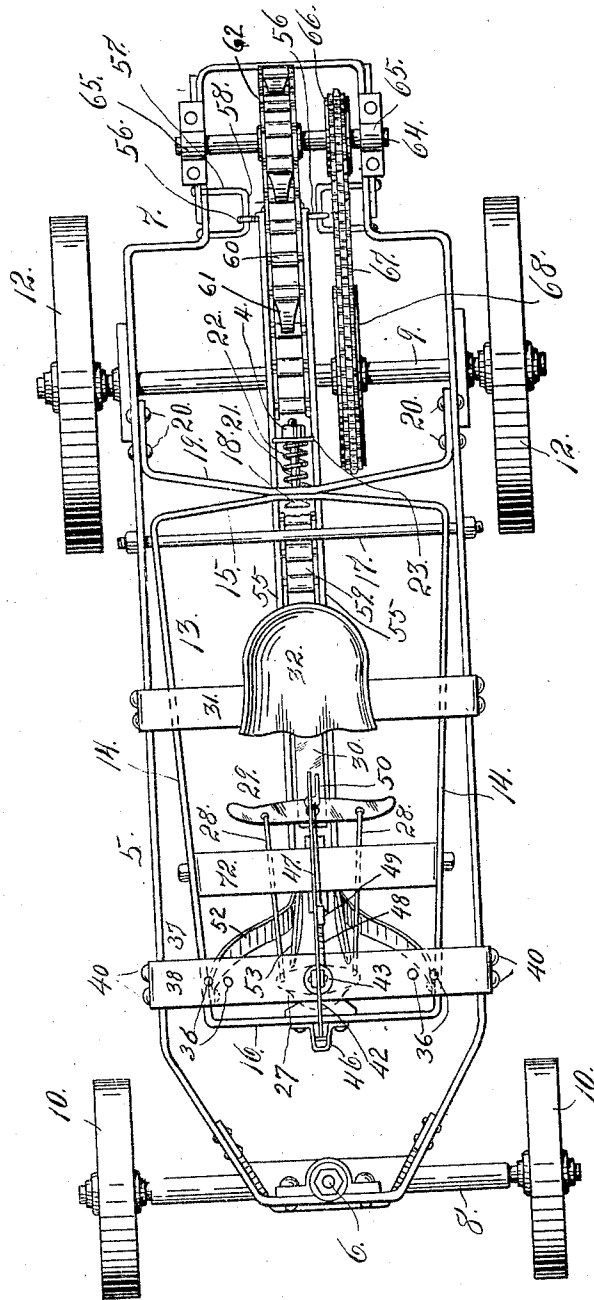

Fig. 4.

Witnesses
Otto E. Hradlich.
C. H. Roessner.

Inventor
William K. Lewis
 By *C. J. O'Brien*
 Attorney

W. K. LEWIS.
BEET HARVESTER.
APPLICATION FILED AUG. 15, 1910.

Patented July 18, 1911.

4 SHEETS—SHEET 3.

998,296.

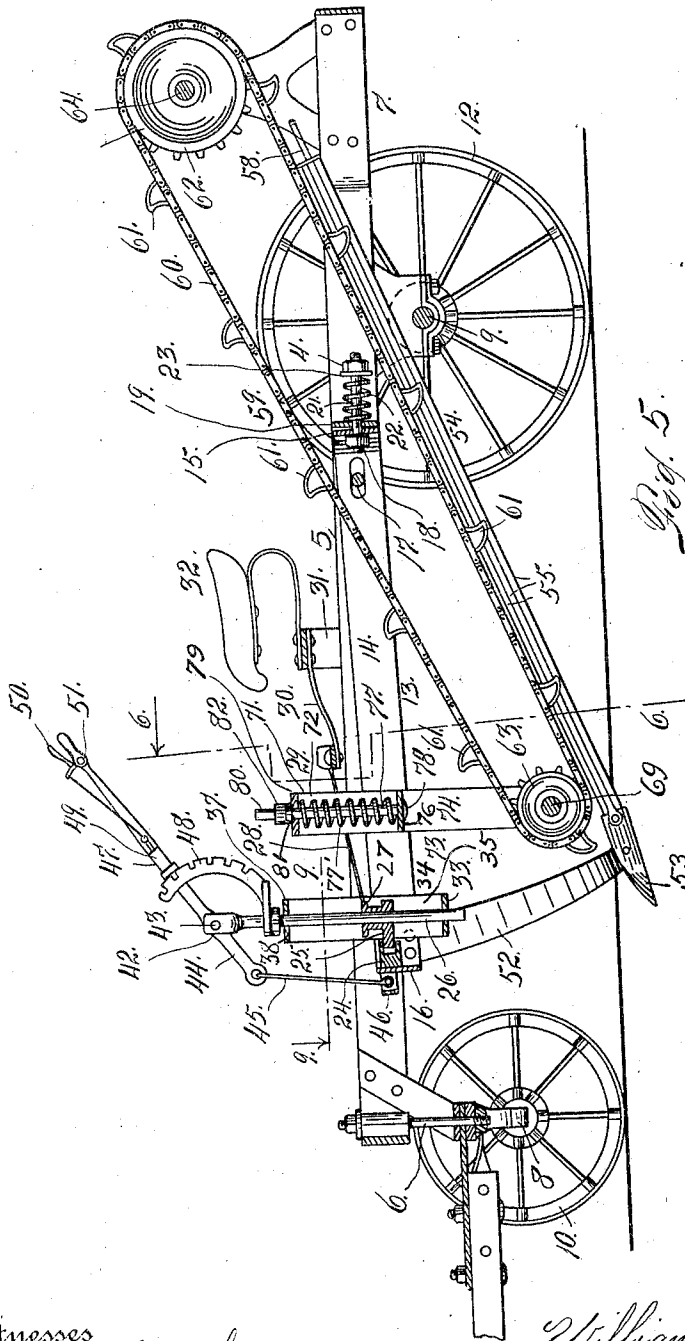

Fig. 5.

Witnesses
Otto E. Haddock.
C. H. Rossmen.

Inventor
William K. Lewis
By O. J. O'Brien.
Attorney

998,296.

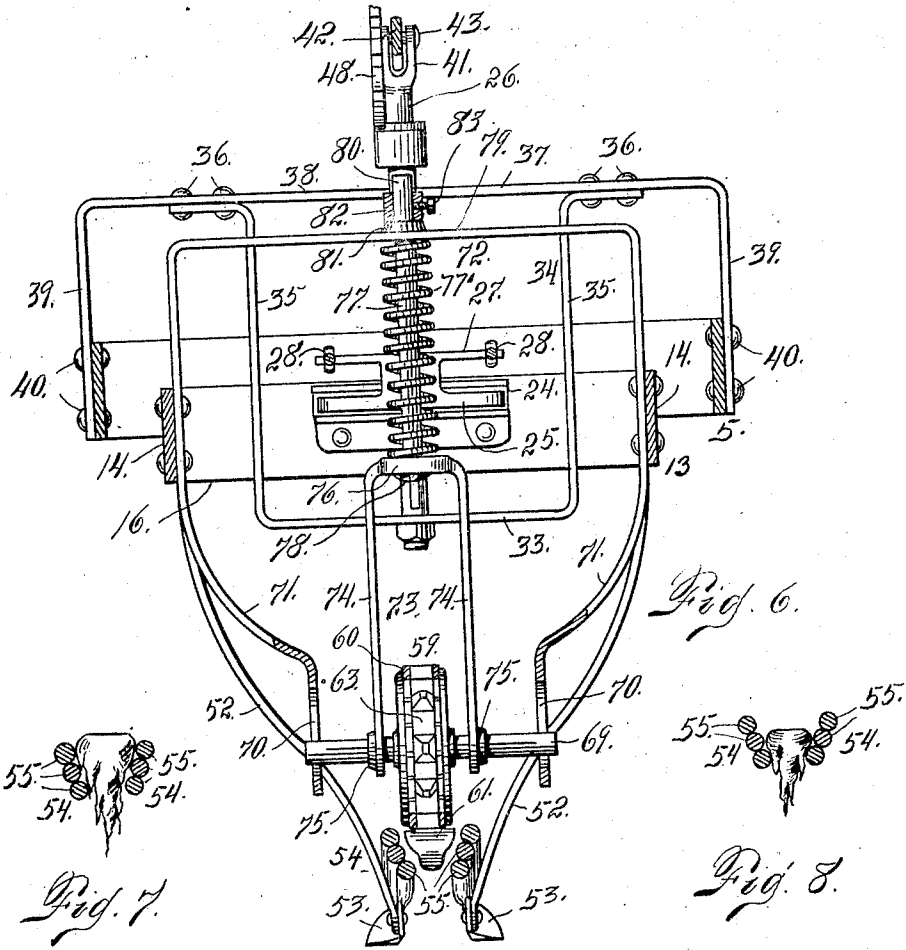

Fig. 7.

Fig. 8.

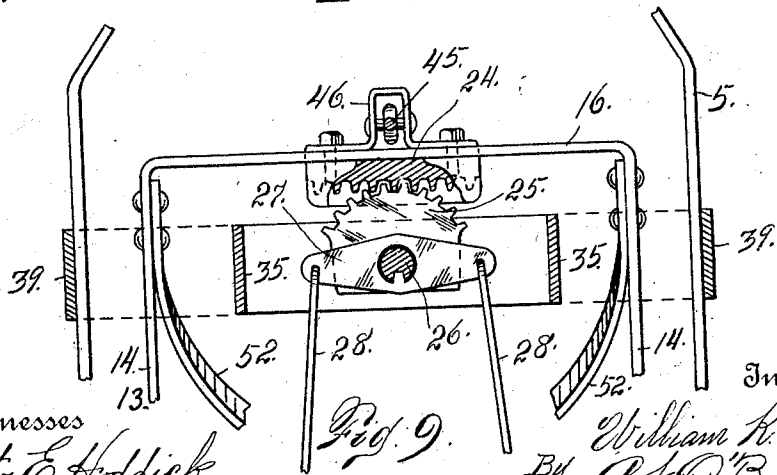

Fig. 9.

Witnesses
Otto E. Haddock.
C. A. Roessner.

Inventor
William K. Lewis
 By *A. J. O'Brien.*
 Attorney

UNITED STATES PATENT OFFICE

WILLIAM K. LEWIS, OF PLATTEVILLE, COLORADO, ASSIGNOR OF ONE-FOURTH TO
DAVID T. BLEVINS, OF WINDSOR, COLORADO.

BEE-T-HARVESTER.

998,296.

Specification of Letters Patent.

Patented July 18, 1911.

Application filed August 15, 1910. Serial No. 577,295.

To all whom it may concern:

Be it known that I, WILLIAM K. LEWIS, a citizen of the United States, residing at the city of Platteville, county of Weld, and State of Colorado, have invented certain new and useful Improvements in Beet-Harvesters; and I do declare the following to be a full, clear, and exact description of the invention, such as will enable others skilled in the art to which it appertains to make and use the same, reference being had to the accompanying drawings, and to the letters and figures of reference marked thereon, which form a part of this specification.

My invention relates to improvements in beet harvesters.

My improved construction is adapted for pulling and elevating the beets. It may be employed in connection with a topper of any suitable construction, since it is assumed that the beets are topped before my machine is brought into requisition. A topping device, however, may be carried upon the same frame that supports my improved mechanism. It will also be understood that an apparatus may be connected with the rear extremity of the machine for piling the beets or for discharging them into vehicles driven along by the side of the machine. The mechanism herein shown and described, however, relates only to the digging and elevating of the beets.

Heretofore, so far as I am aware, little difficulty has been experienced in digging or uprooting the beets, but much trouble has been encountered in elevating the beets to a sufficient height for either piling or delivering into wagons.

With my improved construction two plows or diggers are arranged to pass on opposite sides of the row of beets and as the machine travels over the field, these plows or diggers uproot the beets. Connected with the respective plows and extending upwardly therefrom are two separated guides or guards which support the beets in the upright position as they are uprooted by the plows.

Mounted above the upwardly extending

guards, is an elevator or conveyer provided with flights adapted to act upon the beets and cause them to travel upwardly between the guards. During this operation the guards as above indicated support the beets in the upright position or in approximately the same position which they occupied when in the ground. In fact the beets never change their position from the time they are pulled or lifted out of the ground, until they reach the upper extremity of the trough formed by the two guards. They may then be allowed to drop downwardly to the ground, or they may be delivered to a box arranged to dump at stated intervals where by the beets may be placed in piles of any desired size, or they may be delivered to an elevator or conveyer which extends laterally to a wagon or other vehicle. This apparatus for piling or elevating the beets into wagons, has nothing to do with my present invention and it is therefore neither illustrated in the drawing nor will it be described in detail.

The plows as well as the upwardly inclined guards connected therewith, are supported upon a laterally and vertically swinging frame. The lateral swing of the frame makes it practicable to guide the plows whereby provision is made for uprooting the beets that are out of the regular line of the row, without cutting or injuring them.

One difficulty experienced with the diggers heretofore employed, is that no provision has been made for a lateral movement of the plows through the agency of the driver of the machine, and the consequence has been that beets which are somewhat out of the regular line of the row are cut or broken by the plows, thus virtually destroying them for sugar-making purposes, since it is impossible to remove the sand or dirt, and this dirt ruins the machinery which handles the beets during the sugar-making operation. Beets that are broken by the plows are wasted. Hence the object of my improved apparatus is to overcome this difficulty and prevent the large percentage of waste which has heretofore resulted by the use of imperfect diggers.

Having briefly outlined my improved construction, I will proceed to describe the same in detail, reference being made to the accompanying drawing in which is illustrated an embodiment thereof.

In this drawing Figure 1 is a side elevation of my improved beet harvester showing the plows in position for digging or uprooting the beets. Fig. 2 is a detail view illustrating a pair of links of the elevator chain shown on a larger scale. Fig. 3 is a cross section taken through the upwardly inclined guards and one run of the endless conveyer or elevator. Fig. 4 is a top plan view of the machine, a portion of the conveyer being broken away. Fig. 5 is a vertical section of the machine taken approximately through the longitudinal center of the conveyer, the plows and guards being shown in elevation. Fig. 6 is a vertical cross section taken on the lines 6—6 Fig. 5 looking toward the front or in the direction of the arrow. Fig. 7 is a cross section taken through the guards showing a beet in place or in the position which it occupies during its upward travel. Fig. 8 is a similar view showing a smaller beet in the same position. Fig. 9 is a horizontal section taken on the line 9—9 Fig. 5 looking downwardly, the parts being shown on a larger scale.

The same reference characters indicate the same parts in all the views.

Let the numeral 5 designate the frame work of the machine which as shown in the drawing is composed of metal, having the general shape in plan view of a rectangle. Its forward extremity, however, is somewhat narrowed where it is connected with the bolster 6 of the front axle; while its rear extremity is somewhat reduced as shown at 7. The special shape, however, of this frame work is not material. The frame-work 5 is supported upon a front axle 8, a rear axle 9 and front and rear ground wheels 10 and 12. Located within the area surrounded by the frame 5, is a laterally and vertically rocking or swinging frame 13, which as shown in the drawing is composed of metal, having sides 14, a rear end member 15 and a forward end member 16. As shown in the drawing the side members 14 are farthest apart at the rear where they join the end member 15. These side members approach each other slightly as they extend forwardly and merge into the end member 16. This particular shape, however, is not material. This frame 13 is supported in the rear by a cross bar 17, which is mounted upon the main frame 5, and passes through relatively large openings formed in the side members 14, these openings being of sufficient size to allow the frame 13 a limited degree of lateral or swinging movement, also a vertical movement or oscillation. The central part of the rear

end member 15 is connected as shown at 18 with a stationary transverse member 19, whose extremities are riveted to the side members of the main frame as shown at 20. As shown in the drawing the connection between the members 15 and 19 is formed by a bolt 21 passing through openings formed in the members 15 and 19. The head of the bolt engages member 15 while its shank protrudes rearwardly beyond both members and is surrounded by a spring 22, which is interposed between the member 19 and a stop washer 23, held in place by a nut 4, threaded on the rear extremity of the bolt. This rear extension of the bolt together with the coil spring locked as described, allows the frame 13 to swing both laterally and vertically, the connection 18 being loose enough for this purpose.

Upon the central part of the member 16 of the frame 13 is mounted a cogged or toothed rack 24 which meshes with a segmental gear 25 mounted upon a vertically disposed post 26, the gear being splined on the post and therefore arranged to turn therewith.

Mounted on the post 26 just above the gear 25 is a cross bar 27 which is made fast to the post. From the opposite extremities of this cross bar leads rods 28, which are loosely connected with the cross bar at their forward extremities and at their rear extremities with a similar cross bar 29, which is centrally pivoted to a stationary bar 30 extending forwardly from the stationary support 31 upon which the driver's seat 32 is mounted. By virtue of this arrangement the member 29 is adapted to be easily manipulated by the feet of the driver. In other words, by pressing upon either extremity of the member 29, the forwardly located cross bar 27 may be actuated sufficiently to give the post 26 a partial rotary movement, thus imparting a similar movement to the gear 25 and a lateral swinging movement to the frame 13 by virtue of the fact that the gear 25 meshes with the rack 24 mounted on the forward extremity of the frame 13 as heretofore explained.

The post 26 is journaled below the gear 25 in the bottom member 33 of a stirrup shaped support 34, whose vertical side members 35 have their upper extremities riveted as shown at 36 to the top 37 of a frame member 38, provided with depending side parts 39, whose lower extremities are secured to the opposite sides of the main frame as shown at 40. This post 26 is journaled above the gear 24 in the member 37 of the frame 38. The upper extremity of the post 26 is bifurcated as shown at 41 to receive a lever 42, a fulcrum pin 43 passing through registering openings formed in the upper extremity of the post and the said lever.

The forward arm 44 of this lever is connected by a rod 45 with a bracket 46 secured to the member 16 of the frame 13; while the rear arm 47 of the lever projects within the convenient reach of the driver occupying the seat 32. Mounted upon the upper portion of the post 26 is a notched bar or quadrant 48 adapted to receive a dog 49 operated from a hand piece 50 pivotally connected with the lever in the usual manner as shown at 51. By the use of this lever the frame 13 may be swung laterally in either direction and also given an upward and downward movement, the motion during both operations constituting a sort of rocking movement upon the bolt 21 as a center, the frame 13 being further supported by the cross-bar 17 as heretofore explained.

Connected with the forward extremities of the side bars 14 of the frame 13 are two depending members 52 which approach each other as they extend downwardly, their lower extremities being secured to the plows or diggers 53, which are separated sufficiently to straddle the beets during the uprooting operation. In other words, these plows or diggers enter the ground on each side of the beets and are downwardly inclined, their rear extremities being highest. By virtue of this arrangement, as the plows engage a beet on opposite sides, during the forward travel of the machine, the beet is caused to travel upwardly in accordance with the inclination of the plows and in this manner is uprooted.

Connected with the rear extremities of the plows, are upwardly inclined separated guard members 54, which as shown in the drawing are composed of a number of rods or bars 55, which are circular in cross section and connected together in any suitable manner. The elements 55 of these guards 54 are so arranged that the upper edges of the guard members are farthest apart, the said members converging or approaching each other as they extend downwardly. By virtue of this arrangement it becomes practicable to construct the guard for use with beets of varying sizes. This feature is illustrated in Figs. 7 and 8, a large beet being shown in connection with the guards in Fig. 7 and a small beet in Fig. 8. If the beet is large its upper or larger portion will occupy a more elevated position between the guards, while if it is small it will occupy a lower position, but will nevertheless be retained by the guards and caused to travel upwardly therewith in the manner hereinafter explained.

The upper extremities of the guards 54 are equipped with loops or eyes 56, which loosely engage stationary brackets 57, the said brackets having also the shape of a loop, one member, 58, of which is engaged

by the eye 56 of the guard. This construction and arrangement permit the guards the necessary movement during the vertical and lateral swing of the frame 13.

Located directly above the guards is an endless conveyer 59 composed of a chain 60, equipped with flights 61 located at suitable intervals. This chain is mounted on sprocket wheels 62 and 63, one being located above the upper extremities of the guards and the other just above and rearwardly of the plows, whereby the flights 61 which travel between the guards, are in position to engage the beets and carry them forwardly to the upper extremities of the guards where they may be dropped into a receptacle of any kind, or allowed to fall upon the ground, as may be desired.

The upper sprocket wheel 62 is fast upon a shaft 64 journaled in boxes 65 mounted upon the rear portion of the main frame work. Upon this shaft is mounted and made fast a second sprocket wheel 66, which is connected by means of a chain 67 with a relatively large sprocket wheel 68, fast on the rear axle 9 of the machine. Hence as the machine travels over the field, resulting in the rotation of the axle 9, upon which the ground wheels 12 are fast, motion is transmitted from the rear axle to the shaft 64 and from the latter to the endless conveyer 59.

The sprocket wheel 63 which is located at the lower extremity of the endless conveyer chain, is mounted upon a shaft 69, whose extremities engage vertically elongated openings 70 formed in depending frame members 71 forming a part of a yoke 72 secured to the side members 14 of the swinging frame 13. The shaft 69 is also journaled in an auxiliary yoke 73 whose depending arms 74 carry bearings 75 through which the shaft 69 passes. The upper extremity 76 of the yoke 73 is equipped with a stem 77, whose lower extremity is connected with the top of the yoke as shown at 78. This stem projects above the yoke 73 and passes through an opening formed in the transverse member 79 of the yoke 72 and projects above the upper extremity of this stem above the part 79, is a washer 81 and an adjustable tension collar 82 adapted to be secured in the desired position of adjustment by a set bolt 83. After the tension of the spring 77 is properly regulated, the tension collar is secured in place.

It will be observed that the spring 77 is interposed between the top of the yoke 73 and the top member 79 of the yoke 72. This construction and arrangement allows the shaft 69 with its sprocket wheel 63 which is engaged by the lower portion of the endless conveyer chain, to move vertically in the

slots or elongated openings 70 when for any reason this may be necessary, as for instance when a relatively large beet is uprooted and must be acted upon by the conveyer. By virtue of the construction just described the conveyer is adapted to adjust itself automatically to the various sizes of the uprooted beets with which it comes in contact; while at the same time it is acted upon not only by gravity but by the tension of the spring 77, whereby it is maintained in operative relation when the smallest beet is uprooted. In other words, the conveyer is adapted to act upon any beet, no matter how large or how small, which enters or passes between the members 55 of the guards 54.

While my improved conveyer chain may be of any suitable or desirable construction, I have illustrated in the drawing (see Figs. 2 and 3) two links A and B pivotedly connected as shown at C, and from this illustration it will be understood that the conveyer chain includes links A and B. The flights 61 are mounted upon pins D of the links B of the chain, the said flights as shown in the drawing being composed of metal plates formed in the proper shape for advantageously carrying individual beets upwardly between the guard members 54 during the operation of the machine.

From the foregoing description the use and operation of my improved beet harvester will be readily understood. As heretofore indicated, it must be remembered that the tops of the beets will first be removed. In other words, I contemplate as heretofore stated, the mounting of a topper upon the forward extremity of the frame work of the harvester, the topper being so located as to remove the tops in advance of the plows or diggers. Then as the machine is drawn over the field, the plows occupying a position on each side of the row of beets, the latter are uprooted, being lifted out of the ground by virtue of the downward inclination from the rear extremities of the plows to their forward extremities. The beets are then successively carried from a position between the plows to a position between the guards 54, where they are brought within range of the flights 61 of the conveyer chain, the said chain being kept in motion during the operation of the machine by virtue of the construction and arrangements of the parts heretofore described. From this explanation it will be understood that the uprooted beets are maintained in the upright position from the time they are lifted from the ground by the plows, until they are dropped or discharged at the upper extremities of the guards.

The person in charge of the machine occupies a position upon the seat 32, so that the

cross bar 29 is within convenient reach of the feet. By pressing forwardly upon either end of the bar 29, the swinging frame 13 may be moved laterally in either direction for the purpose of properly guiding the plows to prevent them from injuring beets that may be somewhat out of the direct line of the row. This same function may be accomplished by manipulating the lever 42 in a lateral direction or so as to impart a partial rotary movement to the post 26. Furthermore, by manipulating the lever 42 vertically, it will be understood that a vertically swinging movement may be imparted to the frame 13 together with the plows or diggers. It will be understood that the lifting of the plows together with the corresponding movement imparted to the guards 54, may result in imparting a similar movement to the endless conveyer. However, the plows may be lifted a short distance without disturbing the conveyer, but if the plows are considerably elevated, the conveyer may be correspondingly actuated by virtue of the slots 70 formed in the depending frame members 71 as heretofore explained. It is evident that the plows may be supported in the desired position, by use of the lever 42 and the quadrant 48, the said elements being employed to perform their usual or ordinary functions.

Having thus described my invention, what I claim is:

1. The combination with a main frame work mounted upon ground wheels, of diggers for uprooting the beets, guards extending upwardly from the diggers and in alignment therewith, the upper extremities of the guards being movably connected with the frame work, and a laterally swinging connection between the diggers and the main frame work, substantially as described.

2. The combination with a main frame work, of separated diggers for uprooting the beets, guards connected with the diggers and extending upwardly therefrom, the guards being in alignment with the respective diggers, the upper extremities of the guards being movably connected with the frame, a laterally movable connection between the diggers and the frame, an endless conveyer mounted above the guards and carrying flights adapted to travel between the guards, means for imparting travel to the conveyer from the ground wheels of the machine, and a laterally swinging connection between the frame work and the forward extremity of the conveyer whereby the manipulation of the latter is adapted to harmonize with that of the diggers during their lateral swinging motion.

3. A machine of the class described comprising a main frame work mounted on ground wheels, a laterally swinging frame

mounted on the main frame, diggers for uprooting the beets, an endless conveyer having flights cooperating with the diggers for elevating the beets, the diggers being equipped with separated guards extending upwardly from the diggers on opposite sides of the flights of the lower run of the conveyer, a connection between the diggers and the laterally swinging frame, and a connection between the lower extremity of the endless conveyer and the laterally swinging frame for the purpose set forth.

4. The combination with a frame work, of laterally swinging separated diggers mounted thereon and adapted to pass on opposite sides of the row of beets, guards having their lower extremities connected with the diggers and extending upwardly therefrom and in alinement therewith, the said guards having their upper extremities movably connected with the framework, and a conveyer cooperating with the guards for elevating the beets substantially as described.

5. The combination with a frame work, of laterally swinging separated diggers mounted on the frame work and having correspondingly separated guards extending upwardly from the diggers and movably connected with the frame work, the guards and diggers being supported upon a frame work, and an endless traveling conveyer mounted above the guards and having flights traveling between the guards for the purpose of elevating the beets, substantially as described.

6. The combination with a main frame work mounted upon ground wheels, of separated diggers carried by the frame work and equipped with separated guards extending upwardly from the diggers and movably connected with the framework, the said diggers being mounted to have a lateral swinging movement, and an endless traveling conveyer mounted above the guards and having flights arranged to travel between the guards and cooperating therewith for elevating the beets, the lower extremity of the conveyer being vertically movable and spring tensioned vertically, substantially as described.

7. The combination with a main frame work mounted on ground wheels, of laterally swinging separated diggers carried by the frame work and guards connected with the diggers and extending upwardly therefrom and connected with the frame work to have a limited degree of swinging movement, the guards being separated and inclined toward each other transversely downwardly from their upper edges, the guards being arranged to receive the beets uprooted by the diggers, and an endless traveling conveyer having flights adapted to move upwardly between

the guards for the purpose of elevating the beets, substantially as described.

8. In a beet harvester the combination of diggers, a chute extending upwardly from the diggers, an endless traveling conveyer mounted above the chute and having flights cooperating with the chute for elevating the beets, a shaft for supporting the lower extremity of the conveyer, vertically arranged slots formed in the frame work for receiving the said shaft, a yoke in which the shaft is journaled, a second yoke extending above the first named yoke and a spring interposed between the two yokes, substantially as described.

9. The combination with a main frame work, of an auxiliary frame mounted to swing laterally and vertically on the main frame, a gear journaled on the main frame work, a toothed rack carried by the laterally swinging frame work, a lever in operative relation with the said gear for actuating the gear to impart the lateral swinging movement to the swinging frame, the said lever also being in operative relation with the said frame for imparting vertical movement thereto and uprooting means carried by the swinging frame, substantially as described.

10. The combination with a main frame, of a laterally swinging and vertically movable frame mounted thereon, a gearing connection between the two frames for imparting swinging movement to the auxiliary frame, uprooting means connected with the swinging frame, a post journaled on the main frame, one of the gears being connected to rotate with the post, and means for imparting partial rotations to the post in reverse directions for the purpose of actuating the swinging frame, the said means being also in operative relation with the auxiliary frame for the purpose of vertically moving the same, substantially as described.

11. The combination with a main frame work, of an auxiliary frame laterally and vertically movable thereon, a gearing connection between the two frames for imparting the lateral movement to the swinging frame, uprooting means carried by the movable frame, a post journaled in the main frame and connected in operative relation with one of the gears, and a lever connected with the post to rotate the latter in reverse directions, the lever being also connected with the movable frame for imparting the vertical swinging movement thereto, substantially as described.

12. The combination with a main frame, of an auxiliary frame mounted on the main frame to swing both laterally and vertically, a gearing connection between the two frames

65

70

75

80

85

90

95

100

105

110

115

120

125

for imparting the laterally swinging movement to the auxiliary frame, uprooting means connected with the swinging frame, a post connected in operative relation with one of the gears and a lever connected in operative relation with the post for actuating the gear to impart a laterally swinging movement to the auxiliary frame, the lever being also connected with the swing-

ing frame for imparting the vertical swinging movement to the latter, substantially as described. 10

In testimony whereof I affix my signature in presence of two witnesses.

WILLIAM K. LEWIS.

Witnesses:

T. B. GORMLEY,

Mrs. F. L. BAMFORTH.