



US 20140305265A1

(19) **United States**
(12) **Patent Application Publication**
Haughom

(10) **Pub. No.: US 2014/0305265 A1**
(43) **Pub. Date: Oct. 16, 2014**

(54) **DEVICE FOR ACTIVATION OF GRIPPING
JAWS IN CONTINUOUSLY ROTATING
TORQUE TONGS FOR USE UNDER PULLING
AND OPENING OF THREADED
CONNECTIONS**

Publication Classification

(51) **Int. Cl.**
E21B 19/16 (2006.01)
(52) **U.S. Cl.**
CPC *E21B 19/164* (2013.01)
USPC **81/57.11**

(76) Inventor: **Per Olav Haughom**, Tonstad (NO)

(21) Appl. No.: **14/237,013**

(22) PCT Filed: **Aug. 7, 2012**

(86) PCT No.: **PCT/NO2012/050144**

§ 371 (c)(1),
(2), (4) Date: **Feb. 19, 2014**

(30) **Foreign Application Priority Data**

Aug. 19, 2011 (NO) 20111144

(57) **ABSTRACT**

Continuously rotating power tong for making the threaded connections (2) of pipes, primarily used for drilling for oil and gas in the petroleum industry. The power tong comprising radially movable jaw sections (22), connected to a driving disc (12), where hydraulic pumps (16, 17) are mounted, the pumps (16, 17) being driven by an endless chain (15) through gears (35) and the chain (15) being driven by motors (18, 19) through gears (27, 28).

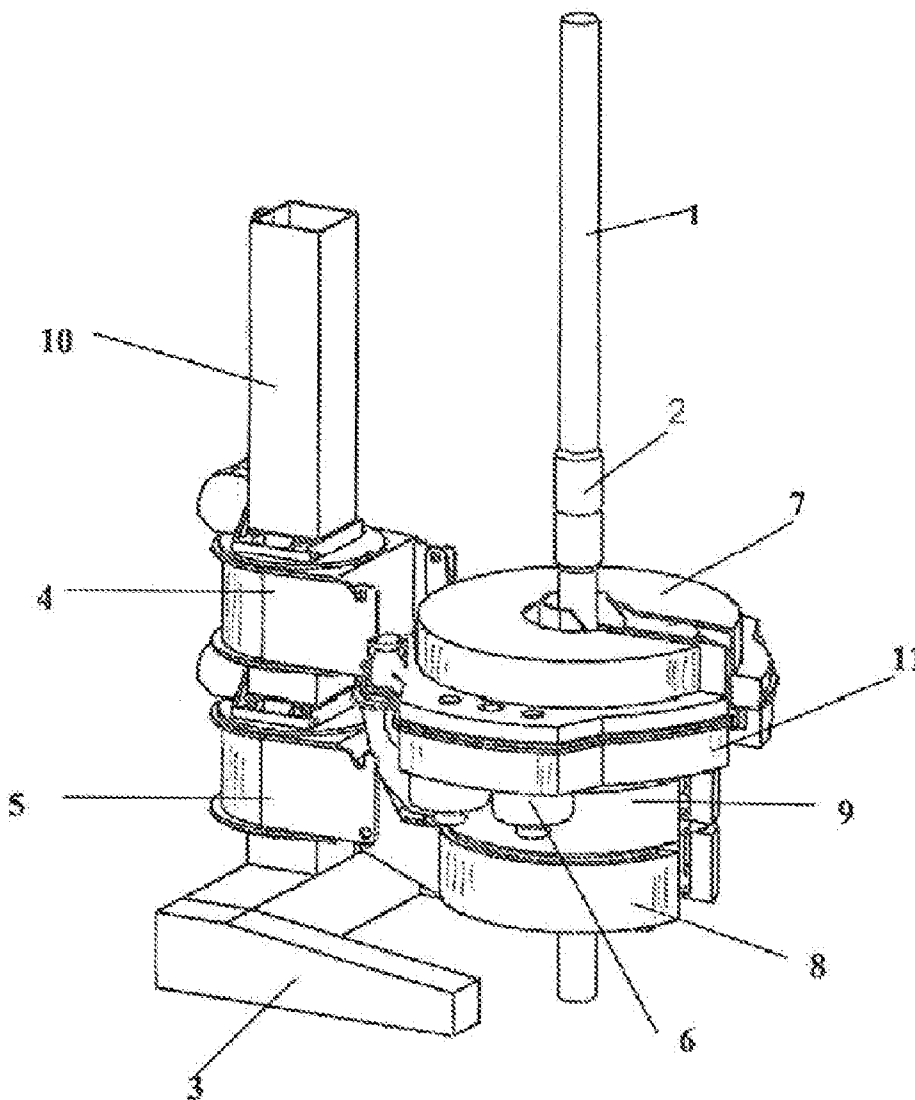

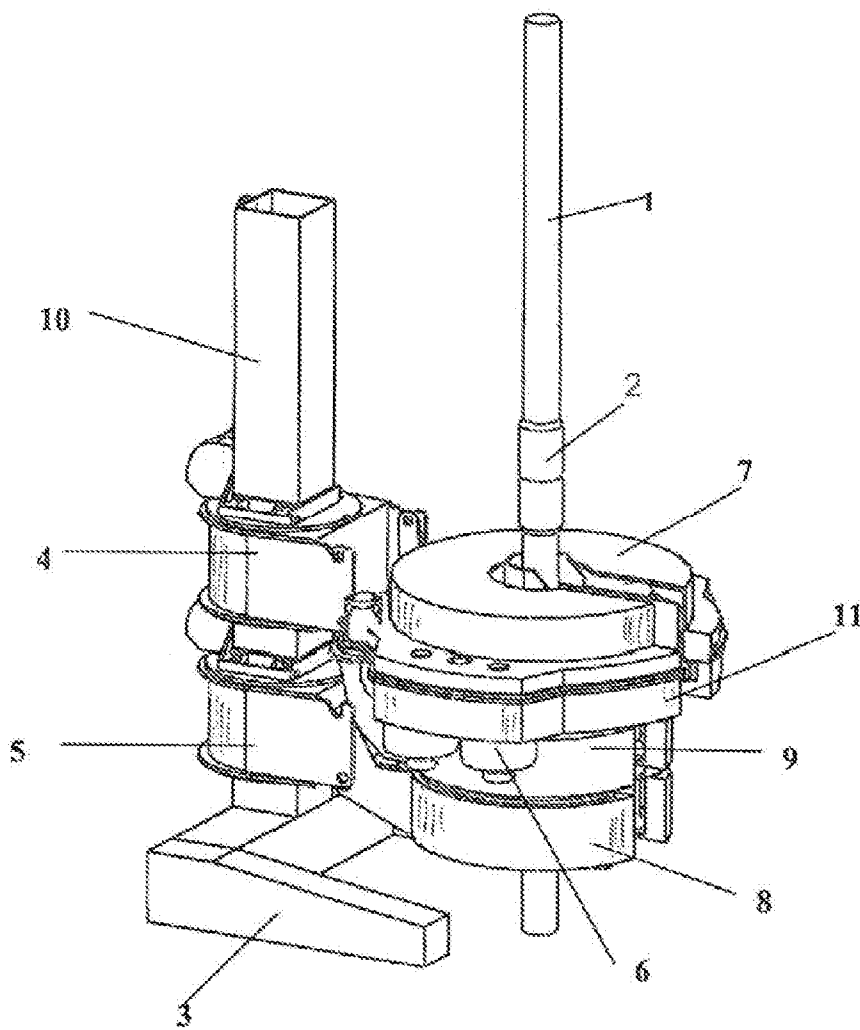

Fig 1

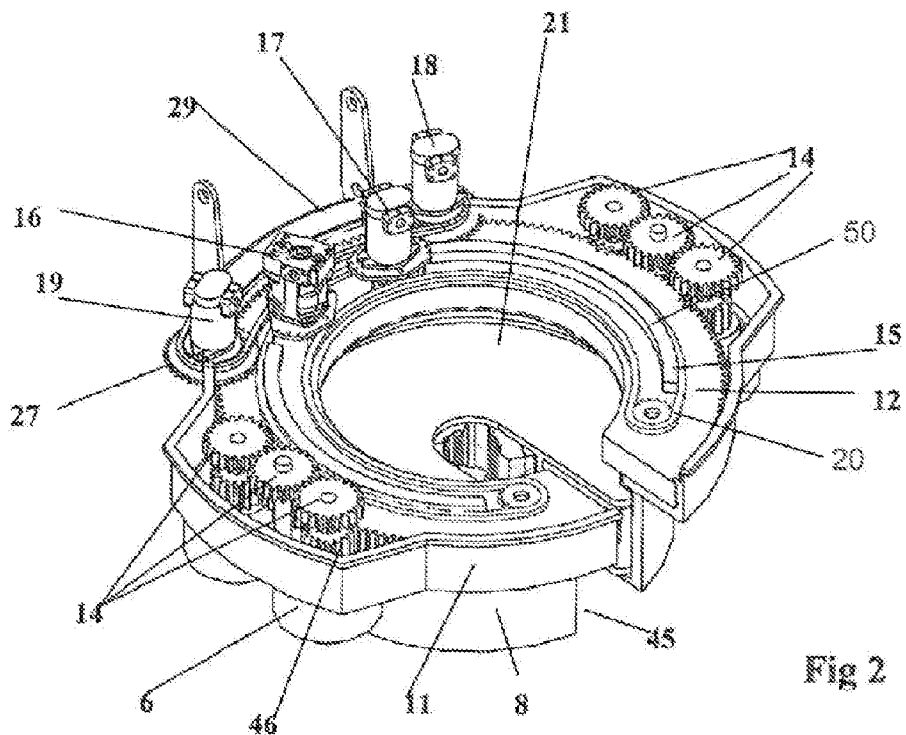

Fig 2

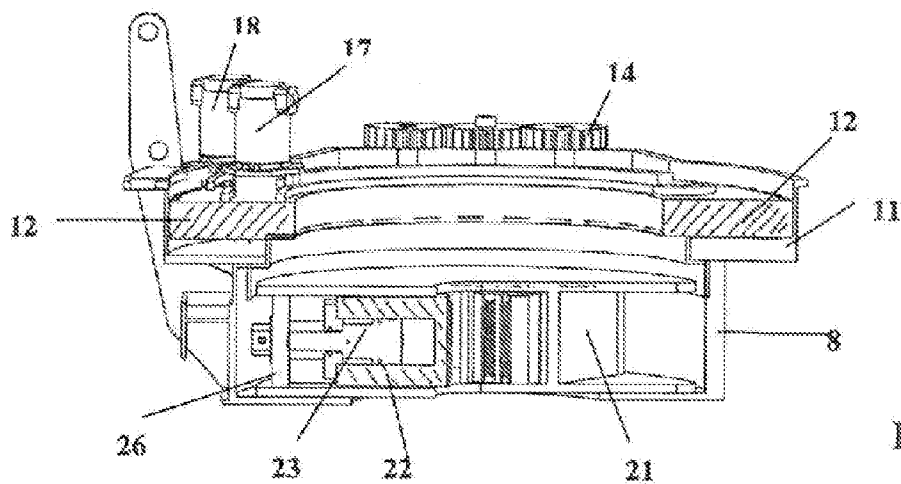

Fig 3

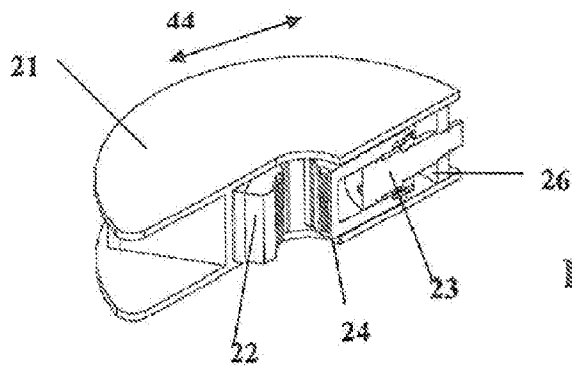

Fig 4

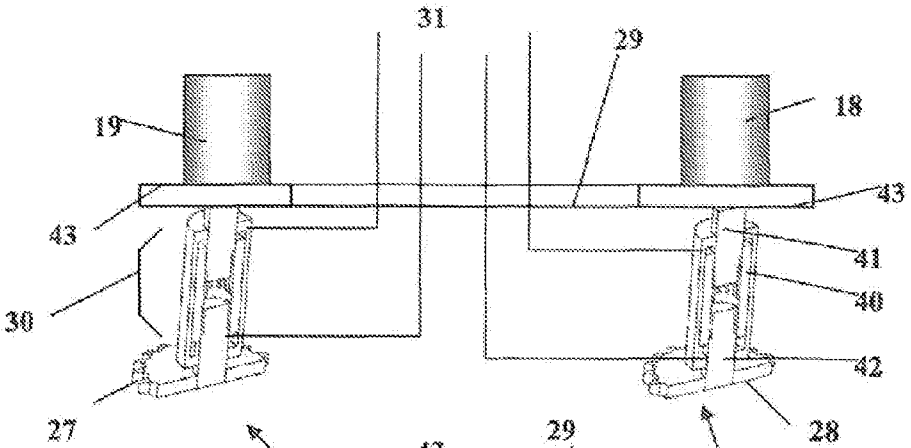

Fig 6

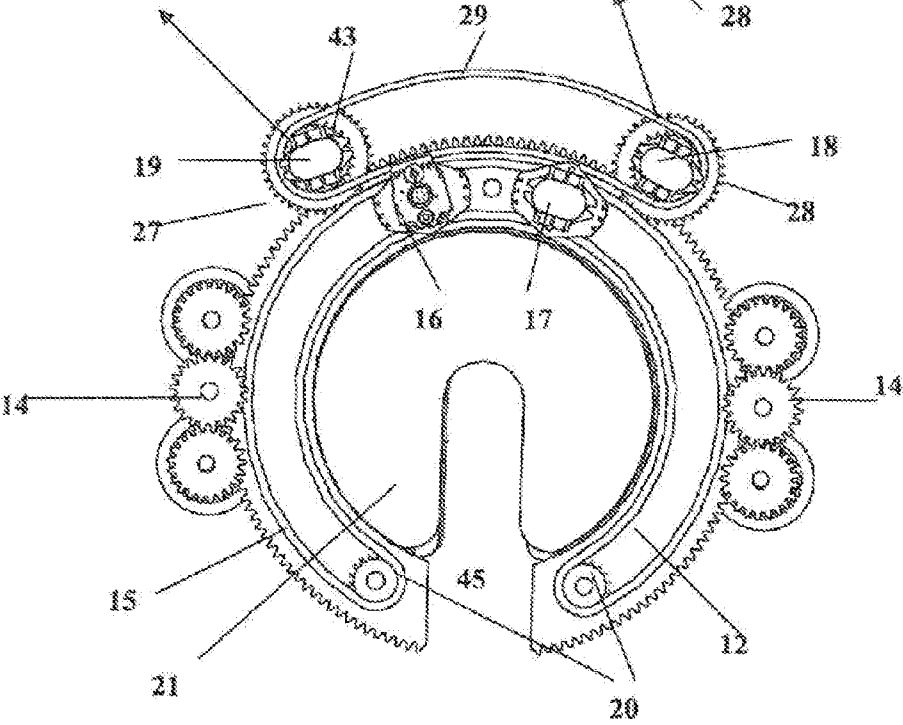

Fig 5

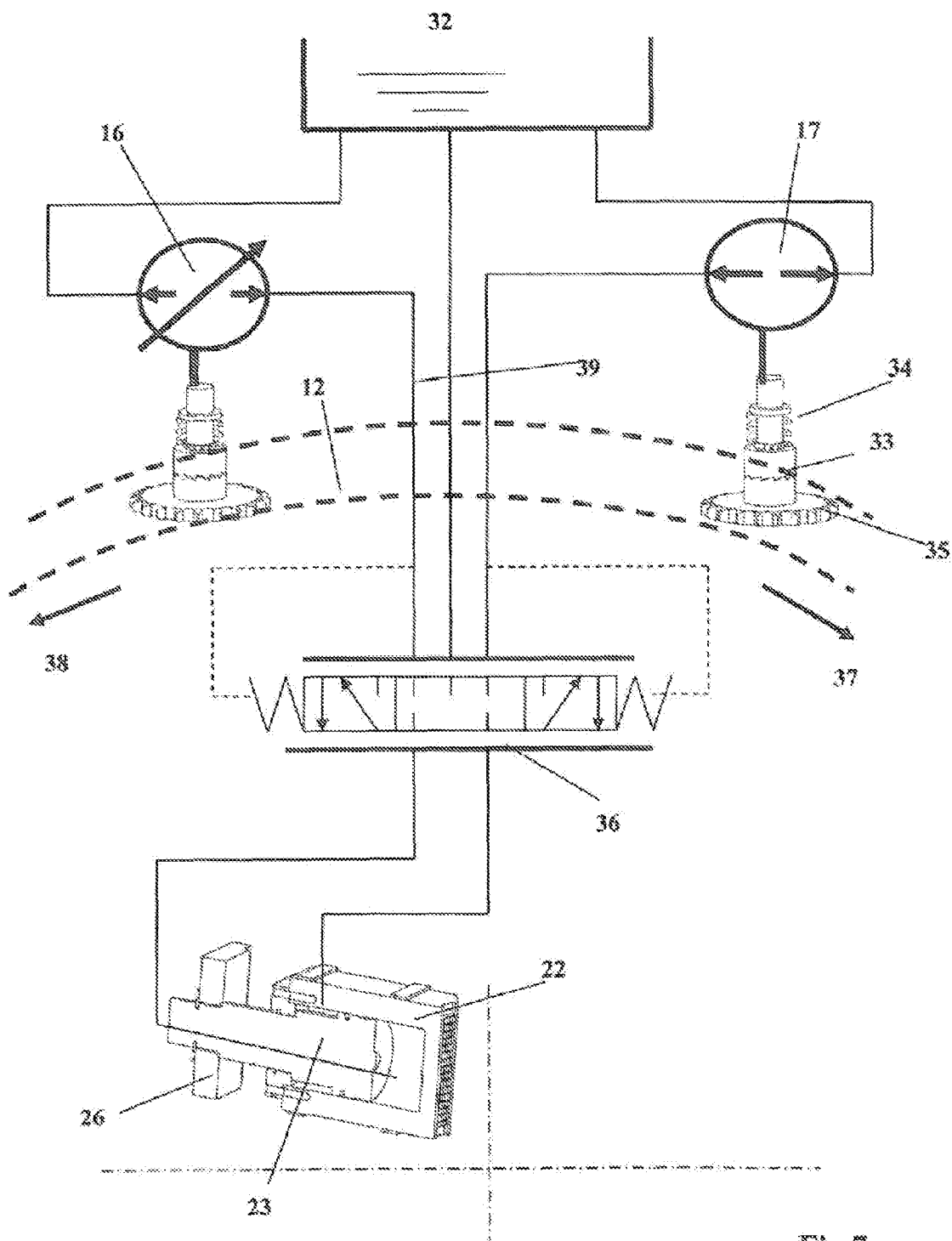

Fig 7

**DEVICE FOR ACTIVATION OF GRIPPING
JAWS IN CONTINUOUSLY ROTATING
TORQUE TONGS FOR USE UNDER PULLING
AND OPENING OF THREADED
CONNECTIONS**

[0001] The present invention relates to torque tongs. More particularly, it relates to a continuous rotation torque tong having a radial opening for inserting and removing threaded connections to be tightened or released.

[0002] The torque tong is particularly well suited for being used for assembling pipe joints during drilling, as known, for example, from petroleum recovery operations.

[0003] The torque tong is provided with an encircling mechanical hydraulic chain arrangement which transfers and supplies pressurized hydraulic fluid to the gripping jaws thereof while the torque tong rotates about the longitudinal axis of the pipe.

[0004] From the petroleum recovery industry, among other fields, it is known to use torque tongs for assembling and disassembling pipe joints for drilling operations.

[0005] It is common to use mechanized pipe tongs, referred to as Iron Roughnecks in the field.

[0006] Various configurations of torque tongs exist, with the most common being provided with a fixed radial opening for radial movement in the horizontal plane when the tongs are engaged with or removed from the pipe string. Generally, the torque tongs are provided with a spinner assembly which, after the pipe joints have been centered relative to each other, effects a rapid rotation of the pipe connection to a limited make-up torque. Thereafter, a hydraulic jacking means is actuated to torque the threaded connection to the desired make-up torque in multiple sequences.

[0007] Torque tongs having no radial opening, no spinner, and with continuous rotation to a desired make-up torque also exist.

[0008] Torque tongs for which the radial opening can be opened and closed are also available, but the mechanical design becomes very complex and this design, therefore, has not gained widespread use.

[0009] Obviously, a variable radial opening of this type in torque tongs which must be able to rotate continuously about the longitudinal axis of the pipe adds complexity to the torque tong design.

[0010] In most drilling operations, it is desirable to be able to pull the torque tong radially outward to allow space for special operations, or to remove the tongs in the case of failure, so that an alternative screw tool can be used. In many operations, especially on floating drilling platforms, safety considerations necessitate the use of torque tongs with radial movement.

[0011] The object of the invention is to overcome, or at least reduce, one or more of the drawbacks of the prior art.

[0012] The object is achieved according to the invention by the features set forth in the description below and in the following patent claims.

[0013] According to the invention, the torque tong is provided with a drive ring having a cogging encircling the vertical axis of the pipe. The drive ring has a permanently open radial opening out from the centre of rotation. The drive ring is rotatably supported in the torque tong housing, and is driven in a known manner by means of hydraulic or electrical motors.

[0014] In the drive ring, at least 3 fluid-operated radially displaceable clamping devices (gripping jaws) are disposed.

The gripping jaws are provided with replaceable grippers in order to maintain a good friction between the pipe wall and gripping jaws.

[0015] Pressurized fluid for operating the gripping jaws is generated locally on the drive ring, on which the necessary hydraulic components with pumps, valves, piping and oil tank for fluid are arranged.

[0016] The supply of power to the hydraulic system of the rotary drive ring is accomplished through an endless rotatable chain supported on drive rings with turning wheels on both sides of the radial opening and circularly about the centre of rotation. Two motors on the non-rotary part of the torque tong can impart rotation to the chain, which is received by two pumps on the rotary drive ring. The motors are positioned with a spacing that is larger than the radial opening and provided with a separate synchronization chain, so that the engagement is not affected when the radial opening rotates by. The motors are also each provided with a clutch, so that the engagement with the chain is only activated when power is to be transferred to the drive ring.

[0017] On the drive ring, the pumps are each provided with a respective backstop, so that rotation of the chain in one direction activates the one pump to open the gripping jaws whereas rotation of the chain in the opposite direction activates the other pump to close the gripping jaws.

[0018] The motors for rotating the drive ring are provided with synchronization wheels, so that the engagement with the cogging is maintained when the wheels pass by the radial opening.

[0019] In a preferred embodiment, the torque tong consists of an upper torque tong having a rotary drive ring assembled with an underlying, fixed holding tong. The assembly is, by means of a vertical structure, connected to a displaceable base for horizontal movement of the torque tong. The torque and holding tongs are normally mutually displaceable in order to be able to compensate for displacement during tightening of the threaded connection and for maintenance access.

[0020] As compared with the prior art, the time spent on assembling and disassembling pipe joints is significantly reduced in that the torque tong performs both the spinner function and torquing in a continuous operation. By avoiding a variable opening and eliminating the need for closing a radial opening, the torque tong is given a simple and robust design with improved operational reliability and simplified maintenance.

[0021] In the following, an exemplary preferred embodiment is described and illustrated in the description below and in the drawings, in which:

[0022] FIG. 1 is a perspective view of a torque tong assembled with a holding tong and a base;

[0023] FIG. 2 shows a torque tong including a rotary drive ring and associated drive motors and pumps and motors for transferring power to the rotary drive ring;

[0024] FIG. 3 shows a sectional view of the torque tong;

[0025] FIG. 4 shows a detailed view of rotary gripping jaws;

[0026] FIG. 5 shows an arrangement for transferring power between a fixed part and a rotary drive ring with gripping jaws;

[0027] FIG. 6 shows a principle of synchronizing and connecting motors using an endless chain transmission;

[0028] FIG. 7 shows a principle of a hydraulic system on a rotary drive ring.

[0029] In the drawings, reference number 1 denotes a drill pipe with a threaded tool-joint 2 for joining two drill pipes. The torque tong, with surrounding steel structures 7 and 11 as well as drive motors 6, are connected to a structure 4 displaceable along a vertical beam 10. The holding tong, with a surrounding steel structure 8, is connected to a structure 5 which is also vertically displaceable along beam 10. Beam 10 is connected to a base 3 which is radially displaceable relative to the vertical axis of pipe 1, so that the entire tong structure can be pulled away from the pipe centre.

[0030] The torque tong itself is constructed around an outer housing consisting of outer housing plate structures 8 and 11. Drive ring 12 is non-rotatably supported in housing 11 and provided with a cogging engaging four motors 6 via gear wheels 46. The motors 6 are rotationally rigidly synchronized with gear wheels 14, so that when the rotation passes by opening 45, proper engagement is maintained with the cogging of drive ring 12.

[0031] Mounted on drive ring 12 is an endless chain 15 running over end rollers 20 on each side of the radial opening 45. Also mounted on drive ring 12 are guides 50 keeping chain 15 in a correct position relative to the centre of rotation.

[0032] Chain 15 can be made to rotate using motors 18 and 19, which are connected to chain 15 via gear wheels 27, 28. Motors 18 and 19 may be rotationally rigidly synchronized by way of an endless chain 29 and a gear wheel 43 connected to a motor output shaft 41. By way of clutch 30, the motors can be engaged with and disengaged from gear wheels 27, 28 so that drive ring 12 is able to rotate with no influence from motors 18 and 19. The motors are only engaged when the drive ring is stationary and the gripping jaws are to be activated.

[0033] The clutch 30 is comprised of splined input and output shafts 41 and 42 connected to a shiftable or moveable sleeve 40 operated by hydraulic or electrical signals 31.

[0034] When gripping jaws 22, 24 are to be activated, drive ring 12 is stationary. Motors 18 and 19 are engaged with gear wheels 27, 28 when clutch 30 is actuated.

[0035] Gear wheels 27, 28 engage chain 15, which is made to rotate and drives gear wheels 35. Gear wheels 35 are each connected to a respective hydraulic pump 16 and 17 through a backstop 33 including a spring 34. Depending on the direction of rotation 37, 38 (shown in FIG. 7) of chain 12 (i.e. chain 15 on drive ring 12), one of pumps 16 or 17 will be actuated to supply pressurized fluid.

[0036] The pump 16 is a variable hydraulic pump which down-regulates the volume when the pressure increases. This pump, through the automatic actuation of valve 36, is connected to the side of gripping jaws 22 which exerts a clamping force against the pipe wall. Pump 17 is a fixed volume pump which is actuated to supply pressure when the gripping jaws are to be pulled away from the pipe wall.

[0037] Gripping jaws 22 comprise an inner piston 23 connected to the outer steel structure 21 through a fitting piece 26.

[0038] A hydraulic unit, arranged on the rotary drive ring 12, is provided with separate hydraulic tank 32 and piping(s) 39.

1. A torque tong for assembling pipes with threaded connections for use in subterranean drilling, as known from the petroleum industry, the torque tong comprising a radial opening for inserting and/or removing pipe or threaded connections and a drive ring non-rotatably supported in surrounding structures, wherein the drive ring is connected to a structure arranged with radially displaceable gripping jaws, and wherein the transfer of power for operating pumps disposed on the rotary drive ring with the radial opening is accomplished through an endless chain driven by motors,

wherein the motors are rotationally rigidly synchronized by means of a synchronization chain via gear wheels, and the chain drives a gear wheel or wheels connected to the hydraulic pumps, with a clutch having a backstop being provided between the pumps and the gear wheels.

2. The torque tong of claim 1, further comprising a clutch between the motors, the clutch being configured for activating and deactivating rotation.

3. The torque tong of claim 2, wherein the motors are connected to and disconnected from the gear wheels by means of the clutch, so that the drive ring is able to rotate with no influence from the motors.

4. The torque tong of claim 2, wherein the clutch comprises splined input and output shafts connected by a shiftable sleeve operated by hydraulic or electrical signals.

5. The torque tong of claim 1, wherein between the pumps a sequence valve is disposed controlling the oil flow depending on the direction of rotation of the pumps.

6. The torque tong of claim 1, wherein the backstop further comprises a spring.

7. The torque tong of claim 1, wherein the drive ring is provided with a cogging engaging the motors via a gear wheel.

8. The torque tong of claim 7, wherein the motors are rotationally rigidly synchronized with a gear wheel, so that, when the rotation passes by the radial opening, proper engagement with the cogging of the drive ring is maintained.

9. The torque tong of claim 1, wherein the endless chain runs over end rollers on each side of the radial opening.

10. The torque tong of claim 1, further comprising guides mounted on the drive ring, wherein the guides are for keeping the chain in a correct position relative to the center of rotation.

11. The torque tong of claim 1, wherein the pump is a variable hydraulic pump which down-regulates the volume when the pressure increases.

12. The torque tong of claim 1, wherein the pump is a fixed volume pump which is activated to supply pressure when the gripping jaws are to be pulled away from the pipe wall.

13. The torque tong of claim 1, wherein the gripping jaws comprise an inner piston connected to the outer steel structure through an adapter.

14. The torque tong of claim 1, further comprising a hydraulic unit mounted on the rotary drive ring, the hydraulic unit being provided with separate hydraulic tank and piping.

* * * * *