

E. C. ATKINS.

Machine for Grinding Saws.

No. 67,480.

Patented Aug. 6, 1867.

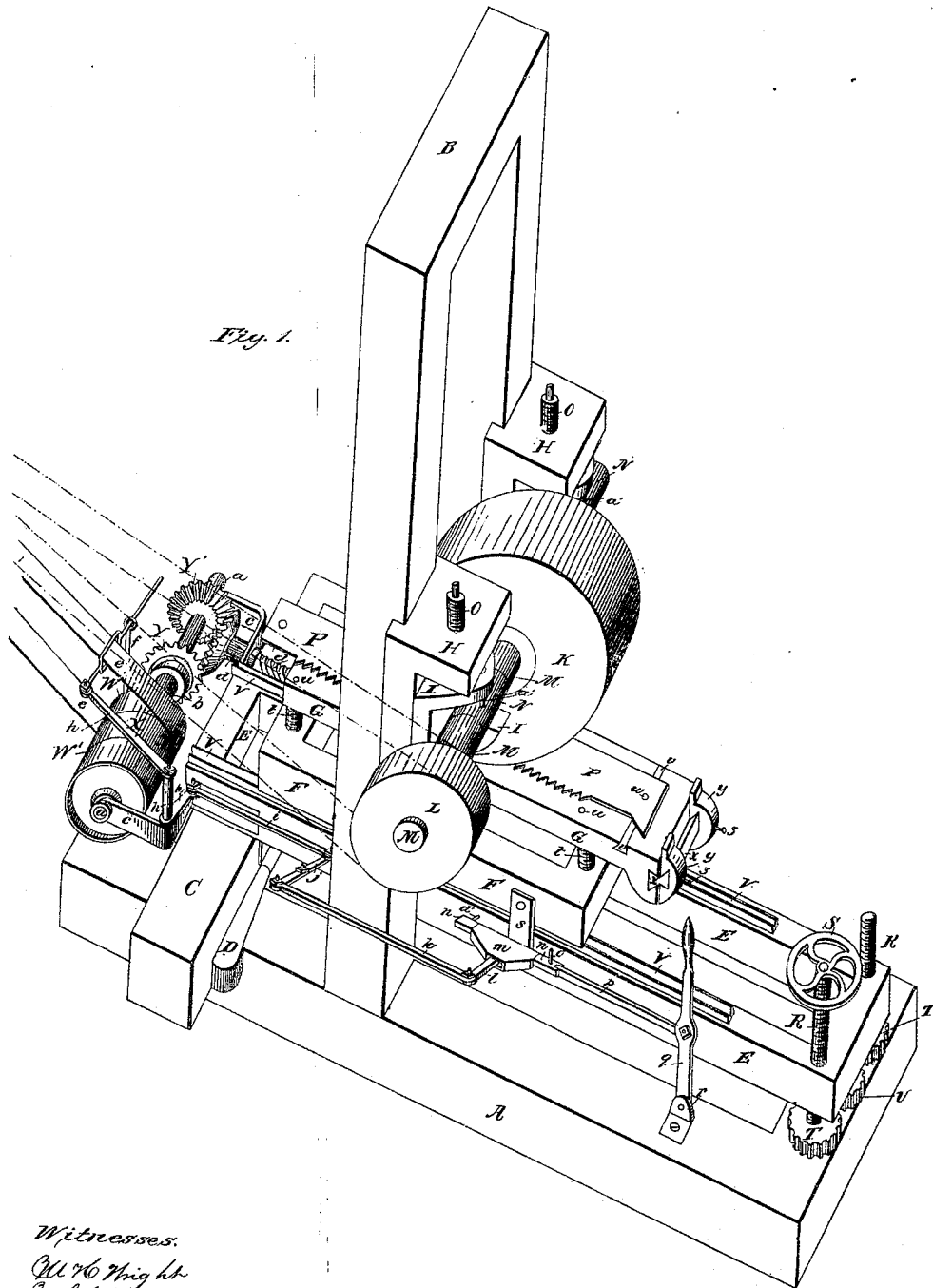

Witnesses:  
Wm. C. Wright  
Wm. L. Smith

Inventor:  
Elias C. Atkins.

E. C. ATKINS.

Machine for Grinding Saws.

No. 67,480.

Patented Aug. 6, 1867.

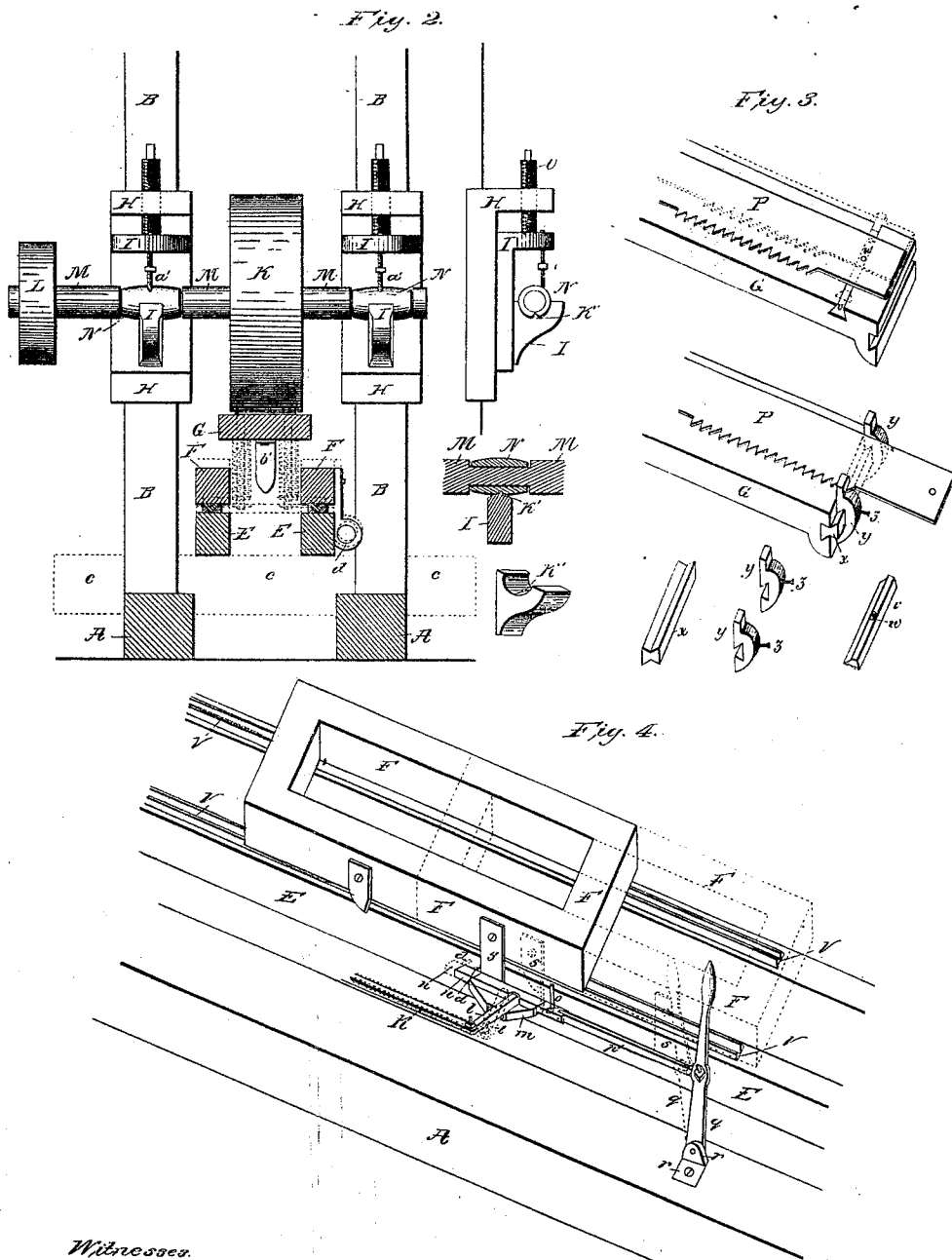

Witnesses:  
 Wm. H. King  
 Jas. Smith

Inventor:  
 Elias C. Atkins

# United States Patent Office.

ELIAS C. ATKINS, OF INDIANAPOLIS, INDIANA.

Letters Patent No. 67,480, dated August 6, 1867.

## IMPROVEMENT IN MACHINES FOR GRINDING SAWS.

The Schedule referred to in these Letters Patent and making part of the same.

### TO ALL WHOM IT MAY CONCERN:

Be it known that I, ELIAS C. ATKINS, of the city of Indianapolis, Marion county, and State of Indiana, have invented a new and improved "Machine for Grinding Long Saws;" and I do hereby declare that the following is a full, clear, and exact description of the construction and operation of the same, reference being had to the annexed drawings, making a part of this specification, in which—

Figure 1 is a perspective view.

Figure 2, an elevation and cross-section.

Figure 3, a section; and

Figure 4 a section.

By the ordinary method of grinding saws, the saw is held in contact with the face of the grindstone, and moved back and forward by the hand. My invention produces the same effect by means of machinery in a similar manner.

The machine consists of the main frame A, fig. 1, on which the machine rests. The upright posts B B support the grindstone-shaft M on which the grindstone K is hung. The shaft M is attached to the upright posts B B by means of the head-blocks H H, which are bolted firmly to the posts. The sliding-bearers I I are held parallel with the head-blocks H H by means of a bolt passing through them and the head-blocks H and posts B, and likewise in position with regard to elevation by means of the adjusting-screws O O. The adjustable boxes N N through which the shaft passes rest on the sliding-bearers I I, which are made oval on the top edge to receive them, as represented at *k'*, fig. 2, and are secured in position without interfering with their adjustment to the line of the shaft M, by means of the pin K', cross-section, fig. 2, and the bolts *a' a'*, fig. 2. The grindstone is rotated by means of a belt passing over the pulley L. As the stone wears it is necessary to lower it, which is accomplished by means of the elevating-screws O O. The saw P is placed upon the table G, secured in position by means of the pin *w* inserted in the slide *v*, or by means of the lugs *y y* attached to the slide *x*; shown in section, fig. 3. The lugs *y y* are movable on the slide *x* to receive any width of saw, and secured in their place, when adjusted, by means of the set-screws *z z*. The table G rests on the springs *t*, six in number, and is held in position, without interfering with the action of the springs, by means of the bolts *u*, six in number, passing through it and the carriage F, and by lugs attached to the under side, projecting down and resting against the cross-bars of the carriage F. These lugs prevent the lateral motion of the table G independent of the carriage F. The carriage F is moved back and forward on the way-frame E in the groove V, to which it is fitted by means of the screw *d* which passes through a nut attached to the carriage F. The screw *d* is rotated by means of the gearing Y Y' and Z; Z being attached to the screw *d*, and Y' Y respectively to the shafts *a* and *b*; *a* being a solid shaft and passing through *b*, which is made hollow to receive it. The shafts *a* and *b* are rotated by means of the belt *e* passing over the pulleys W W' X, being loose upon the shaft *b* to allow the machine to be at rest. The gear-wheels Y Y' being upon opposite sides of the gear Z, move it in opposite directions, while they rotate in the same direction.

In operating the machine the lateral motion of the carriage F back and forth is secured by shifting the belt *e* from one pulley W to the other pulley W' by means of the handle *g*, slide *n* in box *m*, connecting-rods *l k j i c*, and levers *h h* and *l* in box *m*, and the looped rod *g'* passing round the belt *e*; also by means of the lugs *s s'* which, by the motion of the carriage F, to which they are attached are brought in contact with the pins *o d'* in slide *n*; thus the operator may reverse the motion of the carriage F by means of the handle *g*, or the machine will do it by the lugs *s s'* pressing against the pins *o d'*. (See sec., fig. 4.) The springs *t* may be placed under the way-frame E, but do not operate as satisfactorily. The way-frame E is supported at one end by the cross-bar *c*, and at the other end, where the operator stands, by the elevating-screws R R which rest in iron boxes on the main frame A, and are connected together by means of the gear-wheels T T and U, and operated by the wheel S.

### Operation.

In operating, the grindstone K is first set in motion; the saw P is placed upon the table G, and secured by means of the pin *w* or the lugs *y y*. The operator sets the carriage F in motion by passing the belt *e* to the pulleys W, and, by means of the elevating-screws R R, raises the way-frame E, and thus brings the saw P

in contact with the grindstone K. If the saw is narrower than the grindstone, or it is desired to grind only a part at a time, or, in consequence of irregularity of grain, the grindstone tends to wear unevenly, the saw is moved from side to side of the table G, (see sec., fig. 3,) the slides *v* and *x* being inserted in grooves extending across the table G. If it is desired to grind one edge of the saw thinner than the other, this is accomplished by lowering one end of the shaft M by means of the elevating-screws O, the box N adjusting itself to the line of the shaft M, thus avoiding friction. The saw being sometimes harder or thicker in some parts than others, the stone is liable to heat and color these parts. This is obviated by the action of the springs *t*, producing a variable pressure, and at the same time even thickness is secured by the bolts *u* passing through the table G and carriage F and adjusting the height of the table.

What I claim as my invention is—

1. The combination and arrangement of the grindstone K and shaft M, collar N, adjustable boxes I, with pins K', and set-screw O with the reciprocating bed G, supported upon rods *u* and springs *t*, substantially as and for the purpose set forth.

2. In combination with the bed G, rods *u*, and springs *t*, I claim the carriage F and way-frame E, adjustably supported at one end upon the screws B, substantially as and for the purpose set forth.

Witnesses:

WM. SULLIVAN,  
AARON JOHNSON.

E. C. ATKINS.