

A. E. DAVIES.

APPARATUS FOR SEPARATING MAGNETIC MATERIALS FROM OTHER MATERIALS OR FROM LIQUIDS.
APPLICATION FILED DEC. 28, 1908.

979,934.

Patented Dec. 27, 1910.

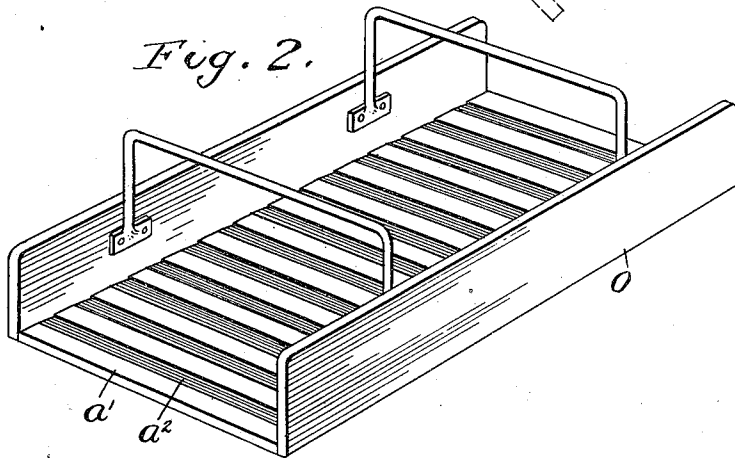
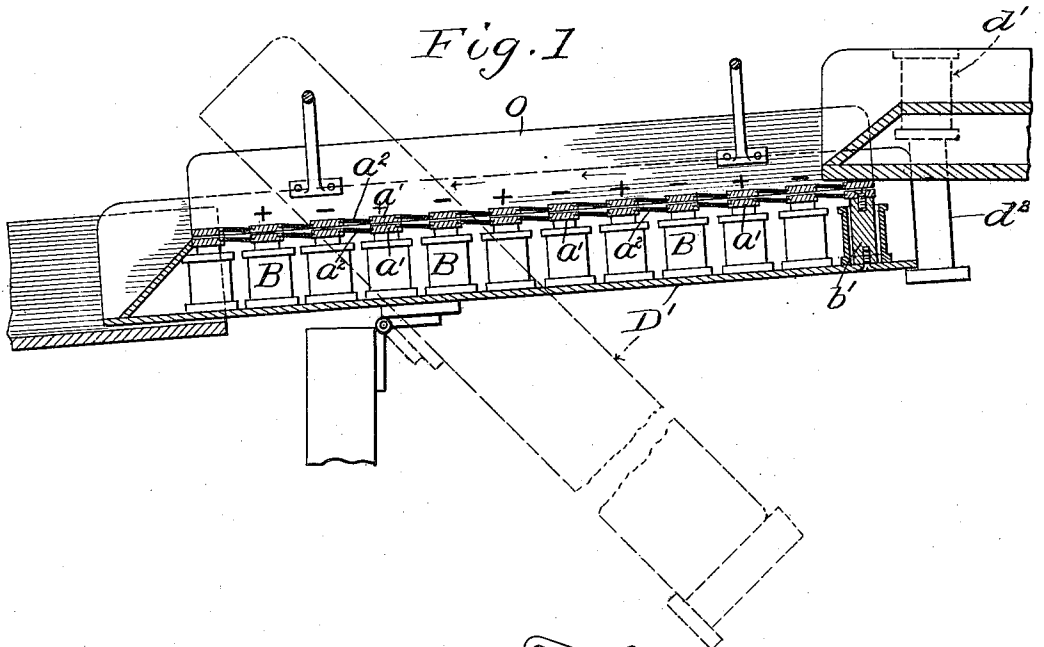

Witnesses;
George M. Davis.
M. Heffling

Inventor
Alfred Evan Davies,
by B. Singer,
Att'y.

UNITED STATES PATENT OFFICE.

ALFRED EVAN DAVIES, OF BIRMINGHAM, ENGLAND.

APPARATUS FOR SEPARATING MAGNETIC MATERIALS FROM OTHER MATERIALS OR FROM LIQUIDS.

979,984.

Specification of Letters Patent. Patented Dec. 27, 1910.

Application filed December 23, 1908. Serial No. 469,620.

To all whom it may concern:

Be it known that I, ALFRED EVAN DAVIES, a citizen of Great Britain, and a resident of 18 The Crescent, Birmingham, in the county of Warwick, England, director, have invented certain new and useful Improvements in Apparatus for Separating Magnetic Materials from other Materials or from Liquids, of which the following is a specification.

The improvements consist in building up a tray or trough with its bottom formed of alternate bars of magnetic and non-magnetic material and in the provision of means whereby the magnetic material accumulated by the magnetic bars may be removed, the object being to compel the materials to be separated to pass over a succession of magnetic edges, to render the apparatus more positive in effecting the purpose for which it is intended.

The invention further consists in providing a structure whereby said trough is pivoted and capable of oscillation, and in the provision of electro-magnetically operated means for maintaining the trough in its working position, this structure permitting of deflecting the flow of material to be treated from the course followed by the purified material, when the magnetism of the separator fails.

The invention is illustrated in the accompanying drawings, in which:

Figure 1 is a longitudinal section of a complete apparatus, showing the arrangement of the supplemental tray and the means for preventing the flow of the liquid over the separator when the magnetism of the separator fails. Fig. 2 is a detail view of the supplemental tray built up in accordance with the invention for insertion in the magnetic trough for facilitating clearing of the magnetic material.

The invention may be used for dry materials which are fed by hand or by suitable mechanical means onto the upper part of the separating tray A and pass down the tray to the bottom edge, separation being effected during such passage. The separating tray A is practically of box form with magnets housed therein. The surface is formed of alternately disposed magnetic and non-magnetic bars a^1 a^2 respectively. The magnetic bars a^1 are preferably of soft iron and are arranged transversely across the tray. They are separated by strips a^2 of non-magnetic

material such as brass and the two sets of strips are preferably connected in the manner illustrated in Fig. 1. The strips a^2 are formed with tenons a^3 at their edges, one toward the underside of the strip and the other projecting from the upper side. The grooves for these in the strips a^1 are about central thus throwing the strips a^2 into an inclined position flush or approximately so with the strips a^1 at one edge and below same at the other, as clearly shown in Fig. 1. As the materials are passing down the tray in the direction of the arrows, Fig. 1, the magnetic material accumulates in the slight recess or pocket which is formed at the edge of each magnetic strip a^1 ; this formation further leaves a defined magnetic edge clear of each non-magnetic bar or strip.

The magnets B are housed in the box part under the surface of the tray. They consist of studs or cores b^1 on longitudinal bars b^2 . The cores may be secured by small pins or studs run in from the underside of the bars b^2 and also by similar pins or studs put in through bars a^1 . The studs are preferably wound in the contrary directions in adjacent transverse rows, or the studs may receive bobbins so wound, that is to say one transverse row is wound in one direction so that all the projecting ends of the studs b^1 are of one polarity and the next transverse row is wound in the contrary direction to cause the studs in that row to possess an opposite polarity. This arrangement of cores with separate windings forming a number of separate poles of the same polarity under each magnetic bar is found very effective giving great strength to the magnetic bars of the tray. The studs or cores b^1 come immediately under the magnetic bars a^1 and the latter are strongly magnetized by contact.

The sides a^4 of the tray, A or one of such sides, may be hinged to enable them to be turned down to facilitate the clearing of the magnetic substance from the tray after an operation, but this is not a necessity and is not shown on the drawings.

In use the current is switched onto the magnetic circuit and the material to be separated fed either by hand or by mechanical means into the tray. The inclination of the tray effects the movement of the material from the back of the tray to the front so that it has to pass over the successive mag-

netic strips and the magnetic material is retained by one or other of these strips while the non-magnetic falls off at the front edge of the tray into a receptacle provided for it.

5 At intervals the current may be switched off, and the magnetic material be swept off the tray into a suitable receptacle.

The apparatus is particularly useful for separating iron or steel particles from liquids such as potters' slip.

10 The separator A may be formed as a part of a trough system along which the liquid flows to the desired position for use or to storage ready for use.

15 The magnetic bars a^1 and non-magnetic bars a^2 of the separator A are rabbeted or otherwise connected and the liquid in its passage down the separator has to pass over a series of successive magnetic edges as is the case with the dry materials in the example previously described. When the bars a^1 and a^2 are suitably rabbeted together a series of pockets or recesses are formed into which the liquid flows so that it is longer in contact with each magnetic edge; the iron in the liquid accumulates in these pockets against the edges of the magnetic strips as will be understood.

Special means may be provided for the effective removal from the trough of the iron or steel reclaimed from the liquid which with such apparatus is of considerable importance. Said means may consist of a tray of magnetic and non-magnetic material built up alternately as before, such as O, Figs. 1 and 2, which is employed inside the fixed magnetic trough; this tray should correspond in size to the trough and being magnetized by induction arrests the iron and steel in the same way as the trough in the previous cases. When built up to correspond with the trough the magnetic and non-magnetic strips of the tray will be spaced and sized to agree with the strips of the trough. To remove the iron and steel the feed is stopped and the current switched off when the tray O can be lifted out of the trough and easily and quickly cleared of the contents.

50 In such cases as that previously mentioned where the liquid to be treated passes over the separator on its way to be worked, it is of great importance to provide a device in case the magnetism of the separator fails, for preventing the flowing of the liquid over the separator to the troughs beyond, which would carry the accumulated particles of iron off the magnets forward into the cleansed material. A device for this purpose is shown at Fig. 1, where the separating trough A is shown as pivoted and capable of oscillation. The trough is held up to its place in the system by electromagnets d^1 attracting iron work such as d^2 on the pivotal trough. The magnets d^1 are in the

same circuit with the windings for magnetizing the separator so that should the current to the latter fail causing demagnetization, the same result is experienced at d^1 and the trough is released and falls causing a break in the feeding trough system. The pivotal trough may in its fallen position, see dotted lines Fig. 1, direct the liquid into a further trough system for return to the tank.

As distinct from other systems a shallow quick flow over the magnetic trough is preferred and is easily obtained by inclining the trough to a suitable angle to the horizontal.

I claim—

1. In combination with a magnetic separator having a tray and means for magnetizing said tray, a supplemental tray adapted for insertion in said first named tray, a portion of the bottom of said supplemental tray being adapted to be magnetized by induction from said first mentioned tray.

2. In apparatus for separating magnetic materials from other materials, a tray having a portion of its bottom adapted to be magnetized, means for magnetizing said bottom portions, and a supplemental tray adapted for insertion in said first named tray, the bottom of said supplemental tray being formed of bars of magnetic and non-magnetic material alternately disposed and adapted to be magnetized by induction from said first mentioned tray.

3. In apparatus for separating magnetic materials from other materials, a tray or trough, the bottom of which is formed of bars of magnetic and non-magnetic material alternately disposed, electro-magnets disposed beneath the tray or trough for magnetizing the bars, a feed trough communicating with said first-named trough, and a supplemental tray adapted for insertion in said first named tray, the bottom of said supplemental tray being formed of bars of magnetic and non-magnetic material alternately disposed and adapted to be magnetized by induction from said first mentioned trough.

4. In apparatus for separating magnetic materials from other materials, a tray or trough, the bottom of which is formed of bars of magnetic and non-magnetic material alternately disposed, electro-magnets disposed beneath the tray or trough for magnetizing the bars, a feed trough communicating with said first named trough, said first named trough being pivoted and provided with magnetizable iron pieces, supplementary electro-magnets adapted to magnetize said iron pieces whereby said first-named trough may be maintained in its normal position, and a supplementary tray adapted for insertion in said first named trough, the bottom of said supplementary tray being formed of bars of magnetic and non-mag-

netic material alternately disposed and adapted to be magnetized by induction from said first mentioned trough.

5 In apparatus for separating magnetic materials from other materials, a tray or trough, the bottom of which is formed of bars of magnetic and non-magnetic material alternately disposed, electro-magnets disposed beneath the tray or trough for magnetizing the bars, a feed trough communicating with said first named trough, and a supplemental tray adapted for insertion in said first named tray, the bottom of said supplemental tray being adapted to be magnetized by induction from said first mentioned trough.

6. In apparatus for separating magnetic materials from other materials, a tray or trough, the bottom of which is formed of bars of magnetic and non-magnetic material alternately disposed, means for magnetizing said bars, a feed trough communicating with said first named trough, means associated with said first named trough whereby the magnetic material accumulated by said magnetic bars may be removed, said first named trough being pivoted and capable of oscillation, and electro-magneti-

cally operated means for maintaining said trough in its working position.

7. In apparatus for separating magnetic materials from other materials, a gravitally bodily shiftable tray or trough, the bottom of which is formed of bars of magnetic and non-magnetic material alternately disposed, means for magnetizing said bars, a feed trough communicating with said first named trough, a supplementary tray adapted for insertion in said first named trough, and shiftable therewith so as to deflect the material fed from the course followed by the purified material, the bottom of said supplementary tray being formed of bars of magnetic and non-magnetic material alternately disposed and adapted to be magnetized by induction from said first mentioned trough, and electro-magnetically operated means for maintaining said first mentioned trough in its working position.

Signed at Birmingham in the county of Warwick, England this 9th day of December A. D. 1908.

ALFRED EVAN DAVIES.

Witnesses:

F. GILBERT BECHTELL,
J. BEAUMONT PERCIVAL.