

ORGANISATION AFRICAINE DE LA PROPRIETE INTELLECTUELLE
(O.A.P.I.)

19



11 N°

12138

51 Inter. Cl.7

A61M 5/32

BREVET D'INVENTION

21 Numéro de dépôt : 1200200217

22 Date de dépôt : 11.12.2000

30 Priorité(s) : SE
25.01.2000 N° 0000211-3

24 Délivré le : 26.12.2002

45 Publié le : 05 MAI 2006

73 Titulaire(s) :

OLOVSON Gudmar
64, rue Saint Charles
F-75015 PARIS (FR)

72 Inventeur(s) : (Le titulaire)

74 Mandataire : CABINET J. EKEME
B.P. 6370
YAOUNDE - Cameroun

54 Titre : Arrangement at a syringe.

57 **Abrégé** : The invention relates to a needle protection arrangement (2) for a hypodermic syringe (1), with a needle protector (2'). The hypodermic syringe (1) includes a container (10) and plunger to which a rod (11) imparts reciprocal motion and a needle (14) affixed to, or fastenable to, one end-part of the container. The needle protector (2) has a sealing membrane (2b) across its tubular cross-section at the opposite end (2a) from the container. The needle protector (2') has a first distinct position (100) prior to use and a second distinct and locked position (200) after use in order to keep the needle from being touched or causing prick injuries. The container (10) has a recess and/or groove serving as fracture scoring when a flexural load is imposed between the container (10) and the needle protector (2').

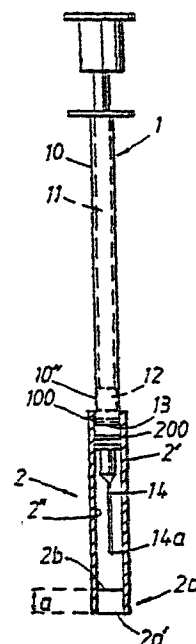

Figure 1

ARRANGEMENT AT A SYRINGE

Field of invention

The present invention relates to an arrangement on a syringe for which a
5 needle protection arrangement is devised.

The needle protection arrangement is devised for co-action with a hypo-
dermic syringe with a container, a plunger arranged for reciprocal movement in-
side the container and needle attached or attachable to one end-part of the con-
tainer.

10 The invention is further based on the use by the said arrangement of a
needle protector with the basic shape of a tube, usually a hollow, circular, cylindri-
cal tube whose axial length is slightly greater than the length of the needle.

More specifically, the present invention is devised for use with a needle
protector in which the tube has an inner, radial-related cross-section correspond-
15 ing to, or at least essentially corresponding to, an outer, radial-related cross-
section for the container.

The cross-section dimensioning of the needle protector enables the device
to be arranged for axial movement in relation to the container from a position cov-
ering the needle to a position exposing the needle or vice-versa.

20 The invention is more specifically based on an arrangement in which a tu-
bular needle protector's axial movement in relation to the container can offer two
distinctly separate setting positions, a first position in which the needle protector is
devised to protect the needle and its point, the free end of the needle protector or
the tube end located next to the needle point, and a second position in which the
25 needle protector is devised to protect the needle and with the free end of the nee-
dle protector or tube end at a greater distance from the needle point while the
needle protector covers the needle and its point, the first setting position being de-
vised to initially pose stiff resistance to movement of the needle protector in rela-
tion to the container.

30

Prior art

There has long been a wish to protect people who handle hypodermic sy-
ringes, used for injection and/or aspiration, against accidental injuries (prick inju-
ries), and several different designs of needle protectors and needle protection ar-

rangements have therefore been proposed to this end.

These needle protectors are usually movably or removably mounted to the container of the syringe and have an elongated shape enabling them in one position to cover the needle and the needle point.

5 The needle protector is removed prior to injection and/or aspiration so as to expose the needle and its point.

For the sake of simplicity, the following description is solely concerned with the injection of liquids, although it will be understood by anyone well-versed in the art that the concept 'injection' is equally applicable to aspiration.

10 A needle and its point which remain exposed after an injection could become contaminated with infectious matter and thereby transmit serious illness to a person accidentally injured by the exposed needle and its needle point.

Different types of needle protector arrangements, which protect people against accidental injury, are known. Such protectors are basically in the form of a
15 tube with a protective seal on tube's free end.

One such needle protector will have the form of a sleeve which can readily be removed from the syringe immediately prior to an injection. This sleeve must be kept separate during the injection process. After the injection, the needle protector must be replaced by hand over the needle so as to shield the needle against un-
20 intentional contact therewith.

A needle protector sleeve of this kind is dimensioned at its open part for a secure but easily released co-action with the part of the needle attached to the container.

25 Other known needle protector constructions are movable over the container and co-act therewith during the injection, the injection syringe and the needle protector then forming a unit.

The present invention relates to the latter category of needle protection means.

30 Earlier known hypodermic syringe constructions with associated needle protection have been described and illustrated in the following patent publications.

US-A-4 425 120

This publication illustrates and describes a needle protector (19) which, in a first position, covers the needle (15) and the point (25) and, in a second, up-

wardly moved position, exposes the needle and the needle point.

The needle protector (19) is tubular here which, at its free end, has a hole (41) large enough to allow a needle-holding means (24) or a needle protector (29) to pass through the hole.

5 The hole (41) may be covered with a material that is punctured by the needle (15) and/or the needle protector (29). The covering material is devised as a sealing end-region of the tubular needle protector and serves to seal the end-related edge or end surface of the tube.

10 US-A-2 571 653

This publication illustrates and describes a needle protector (1) which can be moved reciprocatingly between fixed positions, i.e. between a needle-covering position and a needle-exposing position. The free end of the needle protector (1) is conical and has a central opening which is devised to enclose the needle attachment (4).

US-A-4 725 267

The needle protector shown here has an opening, i.e. a hole (58), and the free end (56) of the needle protector (60) is devised to correspond to the needle (14) cross-section.

A needle protector of the initially cited kind, described and disclosed in the international patent application no. PCT/SE98/01673 (WO99/17822), is also known.

25 More specifically, the invention relates to a construction in which the axial movement of the needle protector or tube in relation to the container has two distinct, separate setting positions, i.e. a first position in which the needle protector is devised to protect the needle and the needle point and with the free end of the needle protector located next to the needle point, and a second position in which
30 the needle protector is devised to protect the needle and the needle point and with the free end of the needle protector located at a greater distance from the needle point while the needle protector covers the needle and its point, the first setting position being devised to initially pose stiff resistance to movement of the needle protector in relation to the container.

The contents of patent publication US-A-4, 801,295 are especially part of the prior art.

This publication illustrates and describes a needle protection arrangement for a hypodermic syringe.

5 It describes a hypodermic syringe with a needle protector which can be moved along the syringe container in order to assume a normal, first position in which the needle protector surrounds and protects the needle.

The needle is at least partially exposed in a second position on the container.

10 In a third position, the needle protector is moved to a needle-covering position and is locked and so firmly attached that it effectively prevents re-use.

Fig. 1 shows a position in which the needle protector is in its first position, fig. 2 shows a position in which the needle protector exposes the needle for use, and fig. 3 shows the needle protector in a third fixed position.

15 Fig. 4 further shows locking for the first position according to fig. 1, fig. 5 shows locking for the second position according to fig. 2 and fig. 6 shows locking for the third position according to fig. 3.

It can then be seen that the position according to fig. 4 has a recess 54 with a sloping surface 56 to facilitate needle protector 42 movement in relation to the container 32 in exposing the needle 38.

20 In the corresponding fashion, the position according to fig. 5 shows a cavity 60 with a sloping surface for providing relative movement, whereas fig. 6 depicts co-action with straight wall sections 64 in order to enclose the part 52 in blocking and locking the needle protector in the lower position.

25 Utilisation of two parallel guide grooves 48 and 50 are shown here. They require the needle protector to be rotated in relation to the container in order to move the needle protector from the second position in the upper part of guide groove 48 to the third position in the lower part of the guide groove 50.

30 ***Summary of the present invention***

Technical problems

When taking into consideration the technical deliberations that a person skilled in this particular art must make in order to provide a solution to one or more of the technical problems that she/he encounters, it will be seen that, on the one

hand, it is necessary initially to realise the measures, and/or sequence of measures that must be undertaken to this end, and, on the other hand, to realise which means is/are required to solve one or more of the said problems. On this basis, it will be evident that the technical problems listed below are relevant to the development of the present invention.

When the prior art, as described above and particularly illustrated and described in the initially cited international patent applications, is considered, it will be seen that a technical problem resides in devising a needle protector arrangement posing initially stiff resistance to movement of the needle protector from a distinct, first position to a position in which the needle is exposed, after completed injection enable bringing the needle protector to a distinct, second position, thereby locking the needle protector to the syringe container in this position and offering an opportunity to crack the syringe at a clearly scored fracture line.

It will also be seen with a needle protection arrangement in which a utilised needle protector can assume one of two or three setting positions in relation to a container, a technical problem resides in producing with simple means conditions in which the needle point can be readily released and exposed, and after an injection, being able to re-cover the needle point by locking the needle protector or tube to the container and letting the first position designate the fracture line.

It will also be seen that a technical problem resides in being able to realise the importance of and advantages associated with only letting the said second position be devised to offer the said locking of the needle protector in relation to the container, and thereby cracking by creating two distinct units with the needle encapsulated in one unit.

It will also be seen that a technical problem resides in being able to realise the importance of and advantages associated with equipping the needle protector with a specially shaped locking boss designed to co-act with a container recess, a transverse groove or vice-versa in order to pose stiff resistance to movement of the needle protector to a needle-exposing position, passing the said first position in moving the needle protector to a second needle-protection position and at which the needle protector is locked to the container, cracking thereby creating two distinct units with the needle encapsulated in one unit and the plunger serving as a seal for the other unit.

It will also be seen that a technical problem resides in being able to realise

the importance of and advantages associated with having slightly bevelled edges, or at least bevels facing a defined direction relative to the movement, on a locking boss in the needle protector arrangement.

5 It will also be seen that a technical problem resides in being able to realise the importance of and advantages associated with having a container recess or groove with bevelled edges, or at least bevels facing one direction relative to the movement, in the said first position.

10 It will also be seen that a technical problem resides in being able to realise the importance of and advantages associated with having a container recess or a groove with squared-off edges, or at least edges facing one direction relative to the movement, in the said second position.

15 It will also be seen that a technical problem resides in being able to realise the importance of and advantages associated with creating conditions in which the needle protector or tube and container become inseparably conjoined in the said second position.

It will also be seen that a technical problem resides in creating, with simple means, conditions in which attempts to defeat locking, when the needle protector arrangement is in its second, locked position, primarily causes the container to break at the first position.

20 It will also be seen that a technical problem resides in creating conditions in which the fracture line is located next to and preferably immediately under the plunger when the plunger is in its lowest position.

25 It will additionally be seen that a technical problem resides in creating conditions in which, after the container has fractured following an attempt to defeat the locking arrangement, one part contains the needle, covered by the needle protector and with the needle protector locked in its second position, whereas the second part contains the larger part of the container with the fracture surface covered in whole or part by the plunger.

30 Solution

The present invention takes as its starting point a needle protection arrangement for a hypodermic syringe, comprising a needle protector in which the needle protector is devised to co-act with a syringe with a container, a plunger capable of reciprocal movement inside the container and a needle affixed to or fas-

12138

tenable to one end-part of the container, the said needle protector basically having the shape of a tube whose axial length is slightly greater than the length of the needle and which includes the features cited in the introduction in other respects.

The invention is also based on the circumstance that axial movement of the needle protector or tube in relation to the container shall have at least two, separate, distinct positions, i.e. a first position in which the needle protector or tube protects the needle and its needle point, the free end of the needle protector or tube being located next to the needle point, and a second position in which the needle protector or tube protects the needle, the free end-part of the needle protector or tube located at a greater distance from the needle point, while the needle protector covers the needle and its needle point, the said first needle position being devised to pose stiff resistance to movement of the needle protector or tube in relation to the container.

With the intention of solving one or more of the aforesaid technical problems, it is proposed in accordance with the invention that the container be provided with fracture scoring so a flexure load on the container and needle protector breaks off and/or bends the container at the said fracture scoring.

According to proposed embodiments that lie within the scope of the invention concept, it is proposed that the said fracture scoring shall be oriented adjacent to or consist of the said first position.

The said fracture and/or bend are devised to form two parts or units, the needle being encapsulated in one unit.

It is also proposed that the said fracture and/or bend shall be devised to form two parts or units, the needle encapsulated in one unit and a fully descended plunger serving as a seal for a second unit.

It is also proposed that the said tube devised as a needle protector be devised so the said second position provides locking and inseparable conjoining of the needle protector or the tube in relation to the container.

As proposed embodiments within the scope of the invention concept, it is further proposed that the needle protector or tube be provided with a locking boss.

It is also proposed that the locking boss have somewhat bevelled edges.

At the said first position, the container shall have a groove with bevelled edges.

At the said second position, the container shall have a groove with

squared-off edges.

In the said second position, the needle protector or tube and the container are inseparably conjoined.

5 The invention also proposes that any attempt to forcibly remove the needle protector from the container, when they co-act in the second position, will cause the container to fracture and destroy its injection capability.

10 The invention also proposes that this fracture produces one part in which the needle point and needle are covered by the needle protector and accordingly encapsulated, whereas the other part comprises the container, the open end-part of which is sealed by the plunger.

Advantages

15 The main advantage regarded as characteristic of an arrangement for a syringe according to the present invention is that it thereby creates conditions for making a needle protector, using simple means, readily movable along the container of a hypodermic syringe.

Sliding the needle protector from a first position along the container to expose the needle and needle point for injection shall be easy.

20 After the syringe has been used, sliding the needle protector over the needle point, past the said first position to a second position in which the needle protector serves as permanent protection, the needle protector and the container being locked and inseparably conjoined in that second position, shall be possible.

25 The primary characteristic features of a needle protection arrangement for a hypodermic syringe according to the present invention are set forth in the characterising clause of the following claim 1.

Brief description of the drawings

30 One proposed embodiment, displaying the significant features of the present invention, will now be described in greater detail, referring to the enclosed drawings in which

Figure 1 shows a side view of a hypodermic syringe with a needle protector according to the invention in a first needle-protection position,

Figure 2 illustrates the syringe and needle protector, according to fig. 1, in a

position in which the needle protector has been slid back along the syringe container to expose the needle,

Figure 3 shows a side view of the hypodermic syringe with a needle protector according to the invention in a second needle-protection position after needle use,

Figure 4 is an enlarged view of the needle protector's co-action with the syringe container in a first position according to fig. 1, and

Figure 5 shows an enlarged view of the needle protector's co-action with the syringe container in a second, locked position according to fig. 3.

Description of preferred embodiments

Fig. 1, shows a side view of a hypodermic syringe 1 to which a needle protection arrangement 2 is attached according to the invention.

The hypodermic syringe 1 illustrated here has a container 10, a rod 11 imparting reciprocating movement to a plunger 12 inside the container 10.

A needle 14 attached (or attachable for certain applications) to one end-part

13 of the container is also illustrated.

Fig. 1 shows that a needle protector 2 in the needle arrangement 2' has the basic shape of tube, with a circular cross-section, whose axial length is somewhat greater than the length of the needle 14.

The length shall be devised so the needle protector 2' covers both the needle 14 and one of the container's end-part 13 and provides free access to the needle point 14a.

The needle protector 2' mainly consists of a tubular member 2' with an inner radial-related cross-section whose shape corresponds to, or at least essentially corresponds to, the shape of the container's 10 external radial-related cross-section.

The needle protector 2', in the form of e.g. the said tube 2', is axially movable in relation to the container 10 from a position covering the needle 14, according to fig. 1, to a needle-exposing position, according to fig. 2, or vice-versa.

At the end-part 2a facing away from the container 10, the needle protector 2' is provided with a thin membrane 2b sealing off the tube's inner cross-section.

'Thin membrane' 2b refers to a membrane thickness much less than the

thickness of the tube 2' material.

The needle protector 2' consists essentially of a section of tubing with a circular cross-section and constant radius and a membrane 2b sealing/closing off the inner cross-section of the section of tubing.

5 The inner, circular surface 2" of the tube 2' is devised for light frictional co-action with the outer circular surface 10" of the container 10.

The said membrane 2b shall be made from a plastic material of such a thickness that moving the tube 2' along the container 10 to expose the needle 14, according to fig. 2, causes the needle point 14a to penetrate the said membrane 10 2b, thereby rendering the syringe 1 ready for use (according to fig. 2), either for injection of a liquid in the container 10 or for aspiration of a liquid for analysis.

The properties of the membrane material should advantageously coincide with the properties of the material from which the tube is made, and it would be advantageous if the needle protector could be manufactured in a single operation.

15 The membrane 2b should advantageously have a thickness less than 0.5 mm, preferably between 0.1 and 0.3 mm, and the material should allow the needle point 14a to form an opening, whose peripheral edge region presses sealingly against the outer surface 14" of the needle 14.

The elasticity of the membrane material shall also enable the membrane 20 2b to stretch around the fastening part 14b of the needle 14, as shown in fig. 2, without rupturing.

Referring to figs. 2 and 3, various alternative setting positions for the needle protector and the container will be described hereinafter in greater detail. However, please refer to the initially cited international patent applications, which can 25 be regarded as part of the present invention, for a detailed account of the basic prerequisites for the present invention.

Figs. 1 and 4 and 3 and 5 show that axial movement of the needle protector 2' or tube in relation to the container can assume two separate, distinct positions, a first position according to figs. 1 and 4 in which the needle protector or 30 tube is devised to protect the needle and its needle point, the free end of the needle protector located next to the needle point, and a second position, according to figs. 3 and 5, in which the needle protector or tube protects the needle, the free end of the tube located at a greater distance from the needle point 14a while covering the needle 14 and its needle point 14a.

The said first position (fig. 1) is devised to pose stiff initial resistance to movement of the needle protector 2' in relation to the container 10, small force then being required to move the needle protector 2' towards the position shown in fig. 2. The first position is the position for an unused hypodermic syringe on delivery, and co-action between the needle protector and container is in the form of a snap fastening.

Even if the position according to fig. 2' can be assumed to be a position for the needle protector in relation to the container, that position will not be the subject of further comment, as the needle protection arrangement assumes a position to expose the needle and its point, and is, accordingly, not a protector in the sense the invention proposes.

More especially, it is proposed that the said second position (fig. 3) be devised to provide locking of the needle protector 2' in relation to the container 10.

This locking means that even if considerable force is employed to move the needle protector on the container in the displacement direction, this force will be incapable of moving the needle protector 2' in relation to the container 10 without causing major material changes, changes so extensive that the syringe is rendered unusable.

More especially, dimensioning of the needle protector 2' and container 10 is such that the unit is destroyed by the said force.

Efforts to force the hypodermic syringe by applying flexural force between the container and the needle protection arrangement will also lead to destruction of the entire syringe.

It may be appropriate to dimension the container 10 so it is bent by the breaking force at a recess devised for the first position.

The illustrated embodiment therefore proposes for this purpose that the needle protector 2' be provided with a locking boss 40.

The locking boss 40 shall have somewhat bevelled edges 41, 42.

In the said first position according to fig. 4, the container 10 has a groove 100 with bevelled or rounded edges 101, 102 enabling the locking boss 40 to slide along and over the edges 101, 102 with some resistance.

In the said second position according to fig. 5, the container 10 has a groove 200 with squared-off edges 201, 202, shown here as rectangular edges.

In the said second position, the needle protector 2' and the container 10

shall be inseparably conjoined. This is illustrated with bevels 41, 41 so narrow that the rectangular sections 43, 44 will abut the edges 201 and 202 respectively.

Devising the boss 40 with longitudinal length somewhat less than the distance between the surfaces 201, 202 may be appropriate.

5 In the position shown in fig. 3, the groove can be positioned next to the upper part of the needle protector 2' and be covered somewhat by the said part.

Even if the embodiment shows that the needle protector 2' is provided with a boss 40 or an edge and the container 10 has a corresponding recess or groove, the container can be provided with the boss or edge and vice-versa.

10 It should be especially noted that if the syringe is subjected to a flexural force, the needle protector and lower part of the container should be devised and attached, as shown in fig. 3, that fracture scoring appears at the groove 100 for the first position. This groove should be positioned a little below the plunger 12 and somewhat above the needle protector.

15 Breaking of the container at the recess 100 can form two parts, one enclosing the needle, its fastening and the lower part of the container. This part will be a closed unit with locking 200 between the needle protector and the container.

The second part will contain the upper part of the container, rod and descended plunger which serves as an end seal.

20 The invention is obviously not restricted to the exemplifying embodiment described above but can be modified within the scope of the invention concept as defined in the following claims.

CLAIMS

1. An arrangement on a hypodermic syringe, consisting of a needle protection arrangement with a needle protector, the syringe having a container holding a rod which imparts reciprocal motion to a plunger in the container and a needle affixed to or fastenable to one of the container's end-parts, the said needle protector having the basic shape of a tube whose axial length is somewhat greater than the length of the needle, the tube serving as a needle protector with an inner radial-related cross-section shaped to correspond to or at least essentially correspond to the shape of the container's outer radial-related cross-section, the said needle protector being axially movable along the container from a needle-covering to a needle-exposing position or vice-versa, the needle protector's axial movement in relation to the container offering at least two separate, distinct positions, a first position in which the needle protector protects the needle and the needle point, the free end of the needle protector being located next to the needle point, and a second position in which the needle protector protects the needle and its point, the free end of the needle protector being located at a greater distance from the needle point while the needle protector still covers the needle and its point, the first position being devised to pose some resistance to movement of the needle protector from this position, **characterized** in that the said container is provided with at least one fracture scoring, and flexural stress imposed on the container and needle protector breaks and/or bends the container at the said fracture scoring.
2. An arrangement according to claim 1, **characterized** in that the said fracture scoring is adjacent to and constitutes the first position.
3. An arrangement according to claim 1 or 2, **characterized** in that the said break and/or bend are devised to form two parts or units, the needle being encapsulated inside one unit.
4. An arrangement according to claim 1 or 2, **characterized** in that the said break and/or bend are devised to form two parts or units, the needle being encapsulated inside one unit, and the fully depressed plunger serves as a seal for a second unit.

5. An arrangement according to claim 1, **characterized** in that the said second position is devised to lock the needle protector to the container.
- 5 6. An arrangement according to claim 1, **characterized** in that the needle protector is provided with a locking boss.
7. An arrangement according to claim 6, **characterized** in that the locking boss has somewhat bevelled edges.
- 10 8. An arrangement according to claim 1, **characterized** in that the container has a recess and/or groove with bevelled edges for the said first position.
9. An arrangement according to claim 1, **characterized** in that the container
15 has a recess and/or a groove with squared-off edges for the said second position.
10. An arrangement according to claim 1, **characterized** in that the needle protector and container are inseparably conjoined in the said second position.
- 20 11. An arrangement according to claim 1, **characterized** in that a first end-part of the needle protector, facing away from the membrane, is provided with a first part of a two-part coupling element between the needle protector and the container.
- 25 12. An arrangement according to claim 11, **characterized** in that the said first part is comprised of an inner radially and/or axially related groove or edge.
13. An arrangement according to claim 10 or 11, **characterized** in that a second part of a coupling element on the container consists of a radially and/or axially
30 related edge or groove.
14. An arrangement according to claim 12 or 13, **characterized** in that the said edge is located next to the said end-part.

15. . . . An arrangement according to claims 1, 6 or 11, **characterized** in that the material in and dimensioning of the needle protector, at least at the first end-part, has properties enabling the needle protector to expand over the said edge.
- 5 16. . . . An arrangement according to patent claim 1 or 6, **characterized** in that a first needle protector end-part, facing away from the membrane, is provided with a first part of a two-part coupling arrangement, the container having two other coupling arrangement parts axially displaced from one other.
- 10 17. . . . An arrangement according to claim 1, **characterized** in that a needle protector membrane (2b) is inside the needle protector (2') at a distance of 2-10 mm, preferably 3-5 mm, from the end surface of the tube.
- 15 18. . . . An arrangement according to claim 1 or 17, **characterized** in that the said membrane is fastened to the needle protector by a ring-shaped reinforcement.
19. . . . An arrangement according to claim 1, **characterized** in that the said needle protector is made from a transparent plastic material.
- 20 20. . . . An arrangement according to claim 1, **characterized** in that the said first position groove serves as fracture scoring when a flexural force is imposed.
- 25 21. . . . An arrangement according to claim 20, **characterized** in that the said fracture scoring groove is located, in the said second position, next to the fully inserted plunger inside the container.
22. . . . An arrangement according to claim 20, **characterized** in that an end-part of the needle protector is located, in the said second position, next to the said groove.

Fig. 1

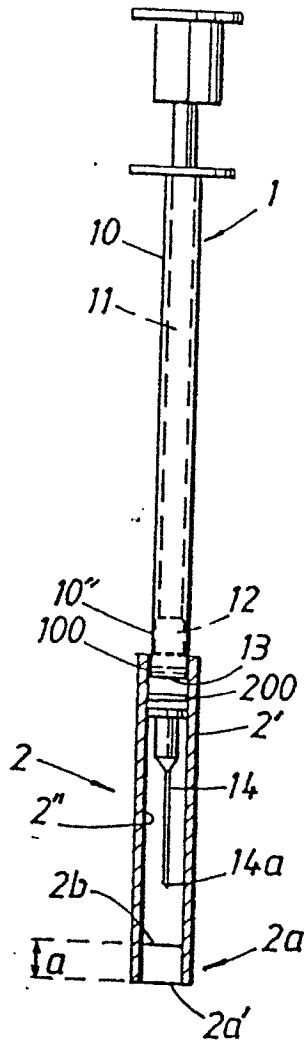

Fig. 2

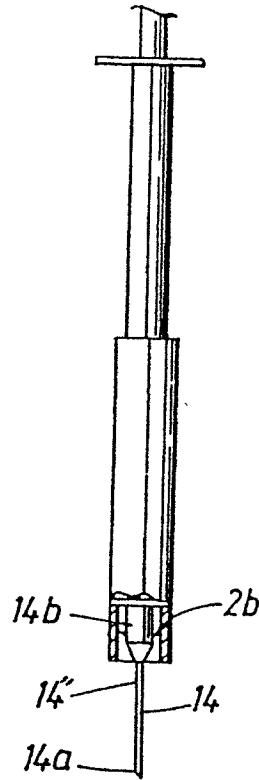

Fig. 3

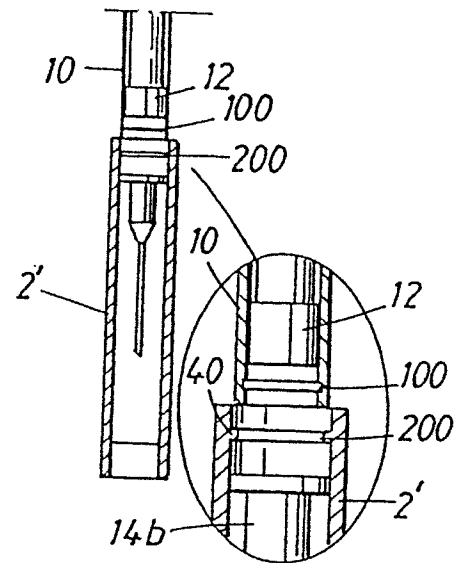

Fig. 5

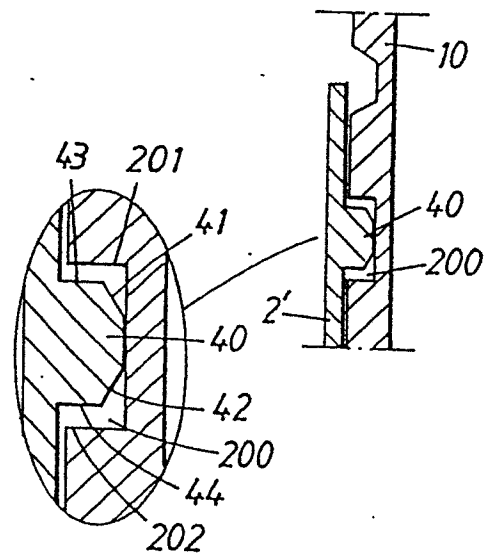

Fig. 4

