

*S. Colahan,
Hay Press.*

N^o 54,864.

Patented May 22, 1866.

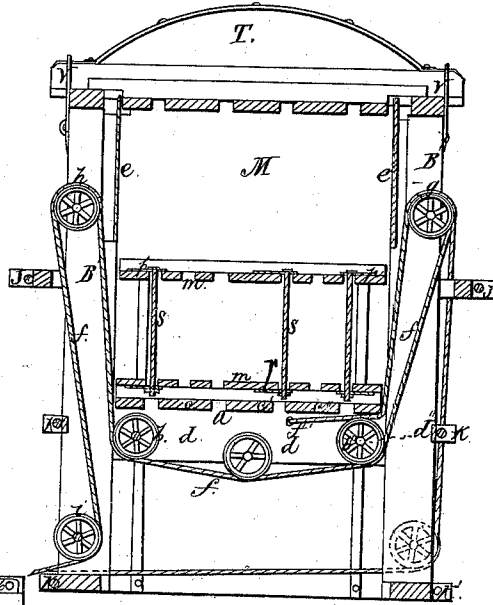
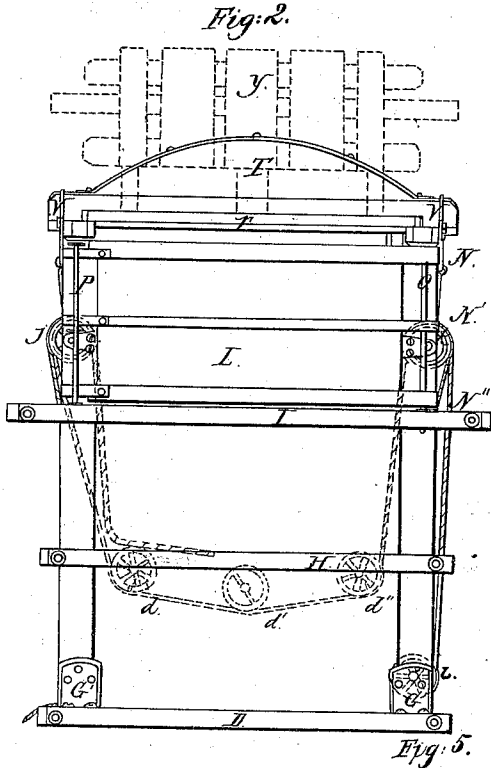
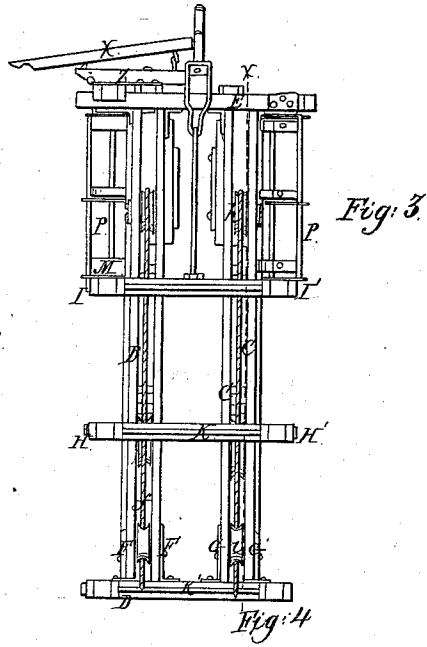
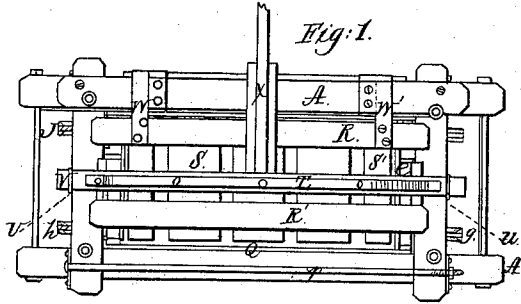

Witnesses:
W. H. Burridge
J. W. Burridge

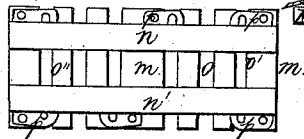

Inventor:
Samuel Colahan

UNITED STATES PATENT OFFICE.

SAMUEL COLAHAN, OF CLEVELAND, OHIO.

IMPROVEMENT IN APPARATUS FOR PREPARING HAY FOR MARKET.

Specification forming part of Letters Patent No. 54,864, dated May 22, 1866.

To all whom it may concern:

Be it known that I, S. COLAHAN, of Cleveland, in the county of Cuyahoga and State of Ohio, have invented certain new and useful Improvements in Preparing Hay, &c., for Market; and I do hereby declare that the following is a full and complete description of the construction and operation of the same, reference being had to the accompanying drawings, making a part of this specification, in which—

Figure 1 is a top view of the press. Fig. 2 is a side view. Fig. 3 is an end view; Fig. 4, a transverse vertical section in the direction of the line *xx* in Fig. 3. Fig. 5 is a follower.

Like letters of reference refer to like parts in the several views.

A, Fig. 1, is a strong wooden frame-work, and comprises the body of the press, and is arranged and constructed as follows: B B' and C C', Fig. 3, are four upright pieces of plank of equal length and size. Two pairs of these form two corners of the press. These pieces are not mortised to the bottom D and top E, but are connected to them by the angle-irons F F' and G G'. Pieces corresponding with these make the corners on the opposite ends of the press, and are connected to the top and bottom in the same way.

To give greater strength to the press the girts H H' and I I' extend across the sides of the press and are bolted together by the iron brace-rods J J' and K K'. These girts may be increased in number more or less according to the size and length of the press. The two upper girts form the sills of the doors L M, Figs. 2 and 3, and upon which they rest and swing open. These doors are also strengthened by girts, the ends of which project beyond the sides of the doors, the ends N N' N'' forming with the top corner of the press and the girt and rod O, Fig. 2, the hinge of the door. The other ends, projecting beyond the door, serve as catches, over which the clamp P, Figs. 2 and 3, are forced for the purpose of holding the doors when closed.

Q, Fig. 1, is a strong trap-door consisting of the lateral sections R R' and the cross-bars S S'. The arch T, Fig. 2, extending the length of the door, is for the purpose of giving to the door additional strength. The ends of the sections R R' extend beyond the end of the door and rest upon the top of the press, thereby

preventing the door from falling downward into the body of the press. So, also, the ends of the timber U, forming the chord of the arch T, project beyond the ends of the press. These projecting ends are for the purpose of holding down the door by means of the loops V, Figs. 2 and 3, which are slipped on over the ends, forming thereby a strong and secure fastening. This door turns upon the strap-hinge W W', and is swung open by the lever X, Fig. 3. The door, when open, falls beyond its center of gravity, and remains in the position indicated by the dotted lines *y*, Fig. 2, by its specific gravity, and the check Z projecting backward beyond the side of the door and striking against the upper side of the press.

Having thus far described the outside of the press, I will now proceed to a description of its internal arrangement, which is as follows: *a*, Fig. 4, is a follower, the sides of which consist of four pieces of plank, two upon each side, parallel with each other. These pieces do not touch each other, there being a space between of sufficient width to receive the sheaves *b b' b''*, each side having three sheaves, the position of the sheaves on one side corresponding with the position of those on the other.

The two sides of the follower are held together by the cross-pieces *c c' c''*. These form the top or bed of the follower. The three rods *d d' d''* hold the lower side of the follower, they also being the shafts of the several sheaves above described.

e e', Fig. 4, are a pair of adjustable sides, the purpose of which will hereafter be described.

The follower is operated in the press as follows: It is supposed to be at the lower end of the press or in the position shown in Fig. 4. The rope *f* is fastened to the follower at *f'*, or at any other convenient point, passing thence over the sheave *g* down to and under the sheaves *b b' b''* in the follower, thence up to and over the sheave *h*, and from thence down to and under the sheave *i*.

To the outside of the press a similar, though somewhat different, arrangement of sheaves and rope is supplied to the opposite side of the press, which is as follows: A rope like the one above described is also connected to the under side of the follower at a corresponding point on the opposite side, or at any other desirable point. This rope then passes over the

sheave *j*, Fig. 2, thence down to and under the sheaves in the follower above mentioned and indicated by the dotted sheaves in Fig. 2, thence up to and over the sheave *k*, from thence down to and under the sheave *l*, and from thence across the press to the outside, where it is united to the first-described rope or its equivalent, and together with it connected to a windlass or other power. The ropes on being pulled draw the follower upward, and by the sheaves and ropes being arranged in the manner described the lifting power is applied equally to the four corners of the follower, and it thereby comes up equally and properly balanced; also, by the distribution of the weight to the several sheaves in the manner described a great power is obtained without much loss by friction.

In order to prevent the sheaves from wearing against the sides of the frame in which they are placed, the angle-irons near the sheaves are provided each with a sleeve, which passes through the frame, and against which the hub of the sheaves works. Sleeves are also provided for the other sheaves and for the same purpose.

In Fig. 5 is a follower, and constructed as shown, *n n'* being two pieces of plank of equal length and size, and parallel to each other, the several cross-pieces *o o' o''* being firmly bolted to them, leaving spaces between. The purpose of the several catches *p p p* will hereinafter be described. This follower is placed upon the bed of the one in the press, the side on which the catches are being downward. The two followers are then lowered to the bottom of the press. The adjustable ends *e e'*, above mentioned, are then pushed in even with the inside of the press, and are prevented from falling inward by the strips *q q'*, Fig. 2. These strips also prevent them from any lateral movement, so that they cannot come out when the side doors are opened. These false sides when pressed in are retained in this position by the cleats, one on each side of the doors. When the doors are closed these cleats pass in back of the ribs between the false sides and the sides of the press. The doors are then fastened by the clamps above mentioned. The trap-door is then thrown open and the material to be baled thrown into the press. When full another follower like the one last described, *m*, Fig. 5, is then placed upon it, the side of which having the catches being upward. The trap-door is then shut down and secured by the loops *v*, above described. This coup-

ling can be lengthened or shortened, as circumstances may require, by the screw and nuts on the ends of the rods, to which they are attached and connected to the press. The brace-rod *r*, Fig. 1, is then placed in its position across the top of the press. The power on being applied to the ropes, the follower then rises upward until its upper side is level with the bottom of the side doors, which are then opened, the rods *s s' s''*, Fig. 4, having a head on one end and a nut and screw on the other for the purpose of adjusting it to the thickness of the bale. It is then placed between the two followers in the position shown in Fig. 4. The catches above mentioned are then slid under the head and nuts, thereby preventing them from being pulled through the spaces between the cross-pieces. These rods hold the top and bottom followers together, holding the pressed material—as hay, cotton, or other like substance—in shape when it is released from the power of the press.

The brace-rod *r*, on being removed from across the top of the press, gives full room for the workmen to remove the bale out from the press to the ground, this being easily done. The false sides above mentioned now being free to move back from the bale leaves it without any obstruction. When removed from the press the hoops, cords, or whatever may be used for binding can be applied by passing it around the bale, the several spaces in the followers allowing the cords or bands thus to pass around them, and when thus properly secured the rods and followers are then removed, to be again used in the manner described.

What I claim as my improvement, and desire to secure by Letters Patent, is—

1. The arrangement of the follower *a* and sheaves, with their respective ropes or chains, in combination with the side doors, *L M*, trap-door *R*, loops *V*, and clamps *P*, substantially as and for the purpose set forth.
2. The followers *m*, bolts *s*, and catches *p*, in combination with the follower, constructed and arranged in the manner and for the purpose substantially as set forth.
3. The adjustable ends *e*, connected with the frame, as specified, in combination with the followers *a m* and side doors, arranged as and for the purpose substantially as set forth.

S. COLAHAN.

Witnesses:

W. H. BURRIDGE,
J. HOLMES.