



(51) International Patent Classification:
F25D 3/08 (2006.01) *F25B 21/02* (2006.01)

(21) International Application Number:
 PCT/US2020/038765

(22) International Filing Date:
 19 June 2020 (19.06.2020)

(25) Filing Language: English

(26) Publication Language: English

(30) Priority Data:

62/866,398	25 June 2019 (25.06.2019)	US
62/887,453	15 August 2019 (15.08.2019)	US
62/955,696	31 December 2019 (31.12.2019)	US
62/970,029	04 February 2020 (04.02.2020)	US

(71) Applicant: **EMBER TECHNOLOGIES, INC.** [US/US];
 4607 Lakeview Canyon Rd., Suite 500, Westlake Village,
 California 91361 (US).

(72) Inventors: **ALEXANDER, Clayton**; 4607 Lakeview
 Canyon Rd., Suite 500, Westlake Village, California 91361
 (US). **LEITH, Daren, John**; 4607 Lakeview Canyon Rd.,
 Suite 500, Westlake Village, California 91361 (US). **TIM-
 PERI, Mikko, Juhani**; 4607 Lakeview Canyon Rd., Suite
 500, Westlake Village, California 91361 (US). **WAKE-
 HAM, Christopher, Thomas**; 4607 Lakeview Canyon
 Rd., Suite 500, Westlake Village, California 91361 (US).
MULINTI, Rahul; 4607 Lakeview Canyon Rd., Suite 500,
 Westlake Village, California 91361 (US). **EMMERT, Ja-
 cob, William**; 4607 Lakeview Canyon Rd., Suite 500,
 Westlake Village, California 91361 (US). **GURNEY, Paul,
 Thomas**; 4607 Lakeview Canyon Rd., Suite 500, Westlake
 Village, California 91361 (US).

(54) Title: PORTABLE COOLER

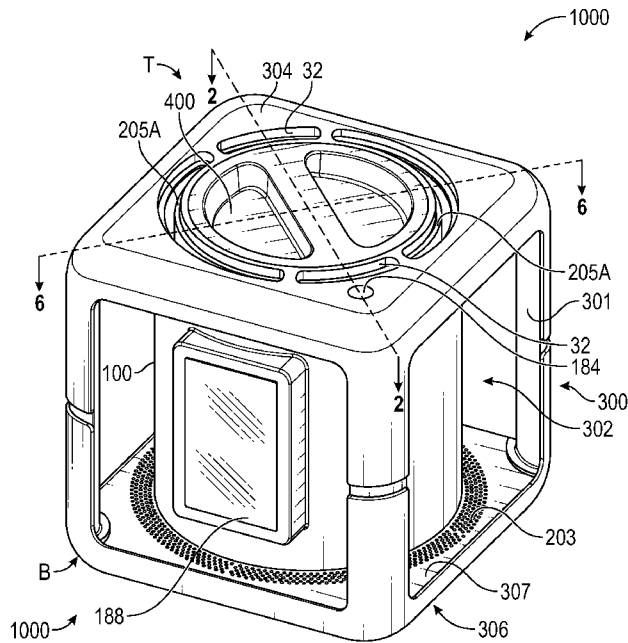

FIG. 1

(57) Abstract: A portable cooler container system (1000") is provided, comprising: a container body (100") having a chamber configured to receive one or more perishable goods; a sleeve (130") disposed about the chamber and housing a phase change material (135") or thermal mass; a conduit (140") extending through the sleeve, an outer surface of the conduit in thermal communication with the phase change material or thermal mass; a lid (400") hingedly coupleable or removably coupleable to the container body to access the chamber; and a temperature control system comprising a cold side heat sink (210") in thermal communication with at least a portion of the conduit, a hot side heat sink (230"), a thermoelectric module (220") interposed between and in thermal communication with the cold side heat sink and hot side heat sink, a pump (146") operable to flow a fluid relative to the cold side heat sink to cool the fluid and to flow the cooled fluid through the conduit in the sleeve to cool the phase change material or thermal mass so that the phase change



(74) **Agent: DELANEY, Karoline, A.;** Knobbe, Martens, Olson & Bear, LLP , 2040 Main Street , 14th Floor, Irvine, California 92614 (US).

(81) **Designated States** (*unless otherwise indicated, for every kind of national protection available*): AE, AG, AL, AM, AO, AT, AU, AZ, BA, BB, BG, BH, BN, BR, BW, BY, BZ, CA, CH, CL, CN, CO, CR, CU, CZ, DE, DJ, DK, DM, DO, DZ, EC, EE, EG, ES, FI, GB, GD, GE, GH, GM, GT, HN, HR, HU, ID, IL, IN, IR, IS, JO, JP, KE, KG, KH, KN, KP, KR, KW, KZ, LA, LC, LK, LR, LS, LU, LY, MA, MD, ME, MG, MK, MN, MW, MX, MY, MZ, NA, NG, NI, NO, NZ, OM, PA, PE, PG, PH, PL, PT, QA, RO, RS, RU, RW, SA, SC, SD, SE, SG, SK, SL, ST, SV, SY, TH, TJ, TM, TN, TR, TT, TZ, UA, UG, US, UZ, VC, VN, WS, ZA, ZM, ZW.

(84) **Designated States** (*unless otherwise indicated, for every kind of regional protection available*): ARIPO (BW, GH, GM, KE, LR, LS, MW, MZ, NA, RW, SD, SL, ST, SZ, TZ, UG, ZM, ZW), Eurasian (AM, AZ, BY, KG, KZ, RU, TJ, TM), European (AL, AT, BE, BG, CH, CY, CZ, DE, DK, EE, ES, FI, FR, GB, GR, HR, HU, IE, IS, IT, LT, LU, LV, MC, MK, MT, NL, NO, PL, PT, RO, RS, SE, SI, SK, SM, TR), OAPI (BF, BJ, CF, CG, CI, CM, GA, GN, GQ, GW, KM, ML, MR, NE, SN, TD, TG).

Declarations under Rule 4.17:

- *as to applicant's entitlement to apply for and be granted a patent (Rule 4.17(ii))*
- *as to the applicant's entitlement to claim the priority of the earlier application (Rule 4.17(iii))*

Published:

- *with international search report (Art. 21(3))*
- *before the expiration of the time limit for amending the claims and to be republished in the event of receipt of amendments (Rule 48.2(h))*

PORTABLE COOLER

INCORPORATION BY REFERENCE TO ANY PRIORITY APPLICATIONS

[0001] Any and all applications for which a foreign or domestic priority claim is identified in the Application Data Sheet as filed with the present application are hereby incorporated by reference under 37 CFR 1.57 and should be considered a part of this specification.

BACKGROUND OF THE INVENTION

Field of the Invention

[0002] The invention is directed to a portable cooler, and more particularly to a stackable portable cooler.

Description of the Related Art

[0003] Portable coolers are used to store products (e.g., liquids, beverages, medicine, organs, food, etc.) in a cooled state. Some are Styrofoam containers that are often filled with ice to keep the product in a cooled state. However, the ice eventually melts, soaking the products and requiring the emptying of the liquid. Such coolers can also leak during transport, which is undesirable. Additionally, such coolers are undesirable for transporting goods across long distances due to their inability to maintain the product in a cooled state, the melting of ice and/or possible leaking of liquid from the cooler. Therefore, such coolers are undesirable for use with temperature sensitive products (e.g., food, medicine, organ transplants, perishable material, etc.). This can result in the non-usability of the products in the cooler. For example, once potency of medicine (e.g., a vaccine) is lost, it cannot be restored, rendering the medicine ineffective and/or unusable. Another drawback of existing containers is that they are single-use containers that end up in the landfills after a single use.

SUMMARY

[0004] Accordingly, there is a need for improved portable cooler designs (e.g., for transporting medicine, such as vaccines, insulin, epinephrine, vials, cartridges, injector pens, organ transplants, food, other perishable solid or liquid material, etc.) that can maintain the

contents of the cooler at a desired temperature or temperature range. Additionally, there is a need for an improved portable cooler design.

[0005] In accordance with one aspect of the disclosure, an improved portable cooler is provided. The cooler can optionally have a vacuum-insulated double wall chamber that can be sealed with a lid (e.g., with a vacuum-insulated lid). This allows the temperature in the chamber to be maintained (e.g., be maintained substantially constant) for a prolonged period of time (e.g., 2 days, 1 day, 12 hours, 8 hours, 6 hours, etc.). Optionally, the chamber can hold perishable contents (e.g., medicine, food, other perishables, etc.) therein and a phase change material (e.g., one or more ice packs, a phase change material sleeve) in thermal communication (e.g., thermal contact) with the perishable contents). Optionally, the cooler has an insulated outer housing (e.g., made of foam, such as lightweight foam).

[0006] Optionally, the container can have a cooling fan and one or more air intake openings. The cooling fan is operable to cool the chamber and/or the phase change material in the chamber.

[0007] Optionally, the container has one or more sensors that sense a temperature of the chamber and/or contents in the chamber and communicate the information with circuitry. Optionally, the sensed temperature information is communicated (e.g., wirelessly, via a port on the container, such as a USB port) with an electronic device (e.g., a smartphone, a cloud server, a remote laptop or desktop computer, a USB drive).

[0008] Optionally, the container has an electronic screen (e.g., digital screen) that can illustrate one or more of a) the temperature sensed by the temperature sensors in the chamber, b) the name of the addressee and/or shipping/delivery address of the container and/or c) the name of the sender and/or shipper/sender address.

[0009] Optionally, the container has a user interface (e.g., a button) that can be actuated by a user to one or more of: a) change the name of the addressee and/or shipping/delivery address of the container and/or b) automatically contact a package delivery service (e.g., FedEx, DHL) to request a pickup of the container.

[0010] In accordance with another aspect of the disclosure, a portable cooler container with active temperature control system is provided. The active temperature control

system is operated to heat or cool a chamber of a vessel to approach a temperature set point suitable for the contents in the cooler container.

[0011] In accordance with another aspect of the disclosure, a stackable portable cooler is provided that allows power transfer between the stacked coolers to charge and/or power the cooling system in the stacked coolers.

[0012] In accordance with another aspect of the disclosure, a stackable portable cooler is provided that allows for removal of heat from each of the stacked coolers without having an upper cooler impede the cooling function of a lower cooler in the stack.

[0013] In accordance with another aspect of the disclosure, a stackable portable cooler container with active temperature control is provided. The container comprises a container body having a chamber defined by a base and an inner peripheral wall of the container body. The container also comprises a temperature control system comprising one or more thermoelectric elements configured to actively heat or cool at least a portion of the chamber, and circuitry configured to control an operation of the one or more thermoelectric elements to heat or cool at least a portion of the chamber to a predetermined temperature or temperature range.

[0014] Optionally, the container can include one or more batteries configured to provide power to one or both of the circuitry and the one or more thermoelectric elements.

[0015] Optionally, the circuitry is further configured to wirelessly communicate with a cloud-based data storage system and/or a remote electronic device.

[0016] In accordance with another aspect of the disclosure, a portable cooler container with active temperature control is provided. A display screen is disposed on a surface of the container body, the display screen configured to selectively display shipping information for the portable cooler container using electronic ink. The display screen is operable to automatically change a shipping address displayed to a different address (e.g., a sender's address for return of the portable cooler to the sender). Optionally, actuation of the display screen to display a shipping address (e.g., a delivery address, a sender's address when the portable cooler is to be returned to the sender), electronics in the cooler wirelessly communicate a signal to a shipping carrier informing the shipping carrier that a shipping

label has been assigned to the portable cooler and that the cooler is ready for pick-up and shipping.

[0017] In accordance with another aspect of the disclosure, a portable cooler container system is provided. The cooler container system comprises a container body having a chamber configured to receive one or more perishable goods. A sleeve is disposed about the chamber and housing a phase change material or thermal mass. A conduit extends through the sleeve, an outer surface of the conduit in thermal communication with the phase change material or thermal mass. A lid is hingedly coupleable or removably coupleable to the container body to access the chamber. The cooler container system also comprises a temperature control system. The temperature control system comprises a cold side heat sink in thermal communication with at least a portion of the conduit, a hot side heat sink, and a thermoelectric module interposed between and in thermal communication with the cold side heat sink and hot side heat sink. A pump is operable to flow a fluid relative to the cold side heat sink to cool the fluid and to flow the cooled fluid through the conduit in the sleeve to cool the phase change material or thermal mass so that the phase change material or thermal mass is configured to cool at least a portion of the chamber. Circuitry is configured to control an operation of one or both of the thermoelectric module and the pump.

[0018] In accordance with another aspect of the disclosure, a portable cooler container system is provided. The cooler container system comprises a container body having a chamber configured to receive one or more temperature sensitive products. A sleeve is disposed about the chamber and housing a phase change material or thermal mass. A conduit extends through the sleeve, an outer surface of the conduit in thermal communication with the phase change material or thermal mass. A lid is hingedly coupleable or removably coupleable to the container body to access the chamber. The cooler container system also comprises a temperature control system. The temperature control system comprises a cold side heat sink in thermal communication with at least a portion of the conduit, a hot side heat sink, and a thermoelectric module interposed between and in thermal communication with the cold side heat sink and hot side heat sink. A pump is operable to flow a fluid relative to the cold side heat sink to cool the fluid and to flow the cooled fluid through the conduit in the sleeve to cool the phase change material or thermal mass so that

the phase change material or thermal mass is configured to cool at least a portion of the chamber. Circuitry is configured to control an operation of one or more of the thermoelectric module, fan and pump. An electrophoretic ink display screen configured to selectively display shipping information for the portable cooler container.

[0019] In accordance with another aspect of the disclosure, a portable cooler container system is provided. The system comprises a double-walled vacuum insulated container body having a chamber configured to receive and hold one or more perishable goods. The system also comprises a lid hingedly coupleable or removably coupleable to the container body to access the chamber. The system also comprises an electronic system comprising one or more batteries and circuitry configured to wirelessly communicate via a cell radio with a cloud-based data storage system or a remote electronic device. A display screen on one of the lid and the container body is configured to selectively display an electronic shipping label for the portable cooler container.

BRIEF DESCRIPTION OF THE DRAWINGS

[0020] Figure 1 is perspective front and top view of a cooler container.

[0021] Figures 2 is a cross-sectional view of the cooler container in FIG. 1 along line 2-2.

[0022] Figure 3 is a partially assembled view of the cooler container of FIG. 1, excluding the frame.

[0023] Figures 4 is a partially assembled view of the cooler container of FIG. 1, excluding the frame and outer vessel wall.

[0024] Figures 5 is a cross-sectional view of the partial assembly in FIG. 4 along line 2-2 in FIG. 1.

[0025] Figures 6 is a cross-sectional view of the partial assembly in FIG. 4 along line 6-6 in FIG. 1.

[0026] Figures 7 is a perspective bottom view of a partial assembly of the cooler container of FIG. 1, excluding the frame and outer vessel wall.

[0027] Figure 8 is a perspective view of a partial assembly of the cooler container of FIG. 1, excluding the frame and outer vessel wall.

[0028] Figure 9 is a perspective view of a partial assembly of the cooler container of FIG. 1, excluding the frame and outer vessel wall.

[0029] Figures 10 is a cross-sectional view of the partial assembly in FIG 9, excluding the frame and outer vessel wall.

[0030] Figures 11 is a perspective bottom view of the partial assembly in FIG. 9, excluding the frame and outer vessel wall.

[0031] Figure 12 is a partial perspective view of the partial assembly in FIG. 9, excluding the frame and outer vessel wall.

[0032] Figure 13 is a perspective top view of a component of the cooler container of FIG. 1, excluding the frame and outer vessel wall and inner liner wall.

[0033] Figure 14 is a perspective transparent view of the component in FIG. 13, excluding the frame and outer vessel wall and inner liner wall.

[0034] Figure 15 is a front view of a cooler container showing the display on a surface of the container.

[0035] Figure 16 is a schematic view showing multiple cooler containers stacked on a pallet.

[0036] Figure 17 shows a schematic illustration of stacked cooler containers.

[0037] Figure 18 shows a schematic perspective bottom view of a cooler container.

[0038] Figure 19 shows a schematic view of stacked cooler containers on a charging base.

[0039] Figure 20 shows a schematic partial perspective top view of the cooler container.

[0040] Figure 21 shows a schematic perspective front view of the cooler container.

[0041] Figure 22 is a schematic block diagram showing communication between the cooler container and a remote electronic device.

[0042] Figure 23 is a schematic block diagram showing electronics in the cooler container associated with the operation of the display screen of the cooler container.

[0043] Figures 24A-24B show block diagrams of a method for operating the cooler container of FIG. 1.

[0044] Figure 25 is a schematic front partially exploded view of a cooler container.

[0045] Figure 26 is a schematic view of a cooler container system.

[0046] Figure 27A is a schematic view of a cooler container system.

[0047] Figure 27B is a partial cutaway view of the cooler container system of FIG. 27A.

[0048] Figure 27C is a partial cutaway view of an example cooler container system.

[0049] Figure 28 is a schematic view of a portion of a cooler container system.

[0050] Figure 29 is a schematic view of an example of a portion of a conduit of a cooler container system.

[0051] Figure 30 is a schematic view of an example of a portion of a conduit of a cooler container system

[0052] Figure 31 is a schematic view of an example of a portion of conduit of a cooler container system.

[0053] Figure 32 is a schematic view of an example of a portion of a cooler container system.

[0054] Figure 33 is a schematic cross-sectional view of a cooler container.

DETAILED DESCRIPTION

[0055] Figures 1-23 illustrate a cooler container assembly 1000 (the “assembly”), or components thereof. Though the features below are described in connection with the cooler container assembly 1000, the features also apply to all cooler containers, such as cooler containers 1000', 1000'', 1000''' disclosed herein. The assembly 1000 can include a container vessel 100, a frame 300 coupled to the container vessel 100, and a lid 400 removably coupleable to a top end T of the container vessel 100. Optionally, the lid 400 can be a double walled vacuum lid.

[0056] In one implementation, the frame 300 can have a rectangular shape (e.g., a square shape) with two or more (e.g., four) pillars 301. However, in other implementations,

the frame 300 can have other suitable shapes (e.g., cylindrical). The frame 300 optionally defines one or more openings or open spaces 302 between the frame 300 and the container vessel 100, allowing air to pass or flow through said openings or spaces 302 (e.g., even when multiple cooler container assemblies 1000 are stacked on top of and beside each other, as shown in FIG. 16).

[0057] A lower surface 307 of the frame 300 can have one or more air intake openings 203 (e.g., an intake grill). As shown in FIG. 1, the air intake openings 203 can be arranged around at least a portion of (e.g., around an entirety of) the periphery of the container vessel 100.

[0058] An upper surface 304 of the frame 300 can have one or more distal vent openings 205A. Figure 1 shows two distal vent openings 205A, though more or fewer openings 205A can be provided in other implementations. The exhaust vent opening(s) 205A can optionally have a curved shape (e.g., semicircular shape). The upper surface 304 of the frame 300 can have one or more electrical contacts 32 (e.g., contact pads, curved contacts). Optionally, the electrical contacts 32 can be recessed relative to the upper surface 304. In the implementation shown in FIG. 1, the frame 300 has two distal vent openings 205A disposed near opposite corners of the frame 300, and two electrical contacts 32 disposed near opposite corners of the frame 300, each electrical contact 32 interposed between the two distal vent openings 205A along a plane that defines the upper surface 304.

[0059] The frame 300 has a bottom surface (e.g., underside surface) 306 that also has one or more proximal vent openings 205B (see FIG. 6) that fluidly communicate with the distal vent opening(s) 205A. The bottom surface 306 also has one or more electrical contacts 34 (see FIG. 5). Optionally, the electrical contacts 34 (e.g., pin contacts, Pogo pins, contact pads) can protrude from the bottom surface 306. Advantageously, when the cooler container assemblies 1000 are stacked (in a column), the electrical contacts 34 on the bottom surface 306 of one frame 300 will contact the electrical contacts 32 on the top surface 304 of an adjacent frame 300 to thereby provide an electrical connection between the adjacent cooler container assemblies 1000. Similarly, when stacked, the proximal vent openings 205B on the bottom surface 306 of one frame with substantially align with distal vent openings 205A of

an adjacent frame 300 to thereby provide fluid communication (e.g., a flow path, a chimney path) between the adjacent cooler container assemblies 1000 (see FIG. 17).

[0060] With continued reference to FIG. 1, the cooler container assembly 1000 also includes a display screen 188. Though FIG. 1 shows the display screen 188 on the container vessel 100, it can alternatively (or additionally) be incorporated into the frame 300 and/or lid 400. The display screen 188 can optionally be an electronic ink or E-ink display (e.g., electrophoretic ink display). In another implementation, the display screen 188 can be a digital display (e.g., liquid crystal display or LCD, light emitting diode or LED, etc.). Optionally, the display screen 188 can display a label 189, as shown in FIG. 15, (e.g., a shipping label with one or more of an address of sender, an address of recipient, a Maxi Code machine readable symbol, a QR code, a routing code, a barcode, and a tracking number), but can optionally additionally or alternatively display other information (e.g., temperature history information, information on the contents of the container vessel 100). In another implementation, the display screen 188 can display an advertisement (e.g., for one or more of the payload components, for example, read by an RFID reader of the container 1000, 1000', 1000'', 1000'''), as further discussed herein.

[0061] The cooler container assembly 1000 can optionally also include a user interface 184. In FIG. 1, the user interface 184 is on the upper surface 304 of the frame 300. In another implementation, the user interface 184 is disposed on the container vessel 100 and/or lid 400. The user interface 184 is optionally a button (e.g., a "return home" button). In one implementation, the user interface 184 is a depressible button. In another implementation, the user interface 184 is a capacitive sensor (e.g., touch sensitive sensor, touch sensitive switch). In another implementation, the user interface 184 is a sliding switch (e.g., sliding lever). In another implementation, the user interface 184 is a rotatable dial. In still another implementation, the user interface 184 can be a touch screen portion (e.g., separate from or incorporated as part of the display screen 188). Advantageously, actuation of the user interface 184 can alter the information shown on the display 188, such as the form of a shipping label shown on an E-ink display 188. For example, actuation of the user interface 184, can switch the text associated with the sender and receiver, allowing the cooler container assembly 1000 to be shipped back to the sender once the receiving party is done with it.

Additionally or alternatively, actuation of the user interface 184 causes a signal to be sent by circuitry in the assembly 1000, as further discussed below, to a shipping carrier (e.g., UPS, FedEx, DHL) informing the shipping carrier that a shipping label (e.g., new shipping label) has been assigned to the portable cooler and that the cooler is ready for pick-up and shipping.

[0062] FIG. 2 shows a cross-sectional view of the cooler container assembly 1000 along line 2-2 in FIG. 1. The assembly 100 can optionally have one or more feet 303 that protrude from the bottom surface 306 can facilitate the positioning and/or interlocking of one assembly 1000 on top of another assembly 1000 when stacking them together. The container vessel 100 can have a chamber 126 defined by an inner wall 126A and a base wall 126B and sized to removably hold one or more materials or products to be cooled (e.g., solids, liquids, food, beverages, medicines, living organisms or tissue). The chamber 126 can in one implementation be cylindrical.

[0063] The assembly 1000 also includes a cooling system 200. The cooling system 200 can optionally be at least partially housed in the vessel container 100. In one implementation, the cooling system 200 can be housed below the chamber 126 (e.g., in one or more cavities between the base wall 126B and the bottom end B of the cooler container assembly 1000). The cooling system 200 can include a first heat sink 210 (e.g., a cold side heat sink), one or more thermoelectric modules or TEC (e.g., Peltier elements) 220, and a second heat sink 230 (e.g., a hot side heat sink). The one or more thermoelectric modules (e.g., Peltier elements) 220 can be interposed between (e.g., in thermal communication with, in thermal contact with, in direct contact with) the first heat sink 210 and the second heat sink 230.

[0064] The cooling system 200 can optionally include a fan 280 in fluid communication with the second heat sink 230, the fan 280 selectively operable to flow air past the second heat sink 230 to effect heat transfer from the second heat sink 230 (e.g., to remove heat from the hot side heat sink 230). The cooling system 200 can include one or more fans 216 in fluid communication with the first heat sink 210, the fan(s) 216 selectively operable to flow air past the first heat sink 210 to effect heat transfer with the first heat sink 210 (e.g., to allow the cold side heat sink 210 to remove heat from the air flowing past the heat sink 210). In the implementation shown in FIGS. 2 and 5, two fans 216A, 216B are in

fluid communication with the first heat sink 210. In one example, the fans 216A, 216B are operable to flow air in the same direction. However, more or fewer fans 216 can be utilized, and can operate in series or parallel to provide air flow. In one example, the fans 216A, 216B are axial fans. In another example, the fans 216A, 216B can be centrifugal fans or radial fans. Other types of fans can be used. As further discussed below the cooling system 200 can flow (e.g., circulate) cooled air cooled by the first heat sink 210 into a channel 107 defined between the inner wall 126A and a second wall 106 (e.g., inner liner wall), the cooled air cooling the inner wall 126A and thereby cooling the chamber 126 and the contents in the chamber 126.

[0065] As shown in FIG. 6, The cooling system 200 exhausts air that flows past the second heat sink 230 (e.g., heated air that has removed heat from the hot side heat sink 230) via air vent assemblies 202A, 202B, where said air enters channels 206A, 206B in the exhaust assemblies 202A, 202B via one or more openings 204A, 204B, where the exhausted air travels upward along the channels 206A, 206B and exits the cooler container assembly 1000 via the distal vent openings 205A. Additionally, the channels 206A, 206B extend to the proximal vent openings 205A, 205B, thereby allowing air from a lower assembly 1000 to also pass through the channels 206A, 206B and exit via the distal vent openings 205A, 205B. Accordingly, when the assemblies 1000 are stacked on top of each other, the channels 206A, 2016B align to allow for (hot) air to exhaust the stacked assemblies 1000 in a chimney like manner (See FIG. 17). As shown in FIG. 7, intake air I flows (e.g., via openings 203) into the assembly 1000 (e.g., via operation of the fan 280) and into fluid contact with the second heat sink 230, after which the exhaust air E is vented via the channels 206A, 206B and distal vent openings 205A.

[0066] With reference to FIGS. 2, 6, 9 and 10, the container vessel 100 can include one or more sleeve portions 130 defined between a third wall 132 and the second wall 106 (e.g., inner liner wall). The one or more sleeve portions 130 can optionally be discrete volumes disposed about at least a portion of the circumference of the second wall 106. The one or more sleeve portions 130 can house a phase change material (PCM) 135 or thermal mass therein. In one implementation, the phase change material 135 can be a solid-liquid PCM. In another implementation, the phase change material 135 can be a solid-solid

PCM. The PCM 135 advantageously can passively absorb and release energy. Examples of possible PCM materials are water (which can transition to ice when cooled below the freezing temperature), organic PCMs (e.g., bio based or Paraffin, or carbohydrate and lipid derived), inorganic PCMs (e.g., salt hydrates), and inorganic eutectics materials. However, the PCM 135 can be any thermal mass that can store and release energy.

[0067] In operation, the cooling system 200 can be operated to cool the first heat sink 210 to cool the chamber 126. The cooling system 200 can optionally also cool the PCM 135 (e.g., via the second wall 106 as cooled air/coolant flows through the channel 107) to charge the PCM 135 (e.g., to place the PCM 135 in a state where it can absorb energy). In one example, one or more fins can extend from the second wall 106 (e.g., into the volume of the sleeve portion(s) 130), for example to enhance heat transfer to the PCM 135. Advantageously, the PCM 135 operates as a passive (e.g., backup) cooling source for the chamber 126 and contents disposed in the chamber 126. For example, if the one or more intake vents 203 are partially (or fully) blocked (e.g., due to dust or debris accumulation in the vent openings 203) or if the cooling system 200 is not operating effectively due to low power, or due to loss of power, the PCM 135 can maintain the chamber 126 and contents in the chamber 126 in a cooled state until the active cooling system can once again operate to cool the chamber 126 and contents therein.

[0068] With continued reference to FIGS. 1-19, the container vessel 100 can include a fourth wall 104 (e.g., outer liner wall) that defines an annular channel 105 between the second wall 106 (e.g., inner liner wall). In one implementation, the annular channel 105 can be under negative pressure (e.g. vacuum), thereby advantageously inhibiting heat transfer with the cooled air flowing through the annular channel 105 to inhibit (e.g., prevent) loss of cooling power and/or improve the efficiency of the cooling loop. An outer vessel wall 102 is disposed about the fourth wall 104. An inlet line (e.g., cool air inlet line, tube, pipe or conduit) 140 can have a proximal end 142 in fluid communication with one end 215A of a cold air fluid chamber 215 and extend to a distal end 144 in communication with the channel 107 between the inner wall 126A and the second wall (e.g., inner liner wall) 106. An outlet line (e.g., cool air exhaust line, tube, pipe or conduit) 150 can have a proximal end 152 in communication with the channel 107 between the inner wall 126A and the second wall 106

and extend to a distal end 154 in fluid communication with an opposite end 215B of the cold air fluid chamber 215. Advantageously, the cold air fluid chamber 215, inlet line 140, outlet line 150 and channel 107 defines a closed system via which a cooled fluid (e.g., cooled air, a cooled liquid coolant) is passed to cool the inner wall 126A and thereby the chamber 126. The air vent assemblies 202A, 202B are arranged about the fourth wall 104 (e.g., outer liner wall), with a gap or channel 103 defined between the air vent assemblies 202A, 202B (see FIGS. 3-4).

[0069] In operation, the fans 216A, 216B operate to drive air past the first heat sink 210 (e.g., cold side heat sink to cool said air) and the air is then directed via the proximal end 142 into the inlet line 140 (e.g., in direction F in FIG. 2, 12). The air flows up the inlet line 140 and exits via the distal end 144 into the channel 107 on one side of dividing wall 109 (see FIG. 8 that extends between the inner wall 126A and the second wall (e.g., inner liner wall) 106. The air then travels within the channel 107 around the circumference of the inner wall 126A until it reaches the dividing wall 109, where it exits the channel via the proximal end 152 of the outlet line 150. The air exits the outlet line 150 at the distal end 154 and into the opposite end 215B of the cool air fluid chamber 215, where the air is again driven by the fans 216A, 216B over the first heat sink 210 (e.g., cold side heat sink 210 to cool the air) and again circulated via the inlet line 140 into the channel 107. Though not shown, valves can be used to regulate the flow of cooled fluid (e.g., air, another gas, liquid) during active cooling mode as well as control convection thermal ingress when the cooler 1000 is operating in passive cooling mode (e.g., when the fans 216A, 216B are not operating, when the PCM 135 is providing the cooling function, etc.). The dividing wall 109 advantageously forces the cooled air to circulate along substantially the entire surface (e.g., substantially entire circumference) of the chamber 126 (e.g., along path C in FIG. 14), thereby providing (e.g., substantially even) cooling to the chamber 126 (e.g., to substantially all portions of the inner wall 126A, thereby cooling substantially all of the chamber 126), and inhibits inefficient, uneven and/or spotty cooling of the chamber 126. In one example, one or more fins can extend from the second wall 106 into the channel 107 (e.g., along the direction of air flow in the channel 107), for example to enhance heat transfer to the inner wall 126A and/or chamber 126.

[0070] The cool air fluid chamber 215 is separated from the hot air fluid chamber 218 (see FIGS. 5-6). In one implementation, thermally insulative material can be interposed between the cool air fluid chamber 215 and the hot air fluid chamber 218. The assembly 1000 can include electronics (e.g., at least partially in a cavity below the base wall 126B, between the base wall 126B and the bottom B of the assembly 1000) operable to control the operation of the fans 280, 216A, 216B, thermoelectric module(s) (TECs) 220, and display 188. The electronics can include circuitry (e.g., control circuitry, one or more processors on a printed circuit board, a CPU or central processing unit, sensors) that controls the operation of the cooling system 200, and optionally one or more batteries to provide power to one or more of the circuitry, fans 280, 216A, 216B, regulating valves and thermoelectric module(s) (TECs) 220. In one implementation, the assembly 1000 can optionally have a power button or switch actuatable by a user to turn on or turn off the cooling system.

[0071] Optionally, the bottom B of the assembly 1000 defines at least a portion of an end cap that is removable to access the electronics (e.g., to replace the one or more batteries, perform maintenance on the electronics, such as the PCBA, etc.). The power button or switch is accessible by a user (e.g., can be pressed to turn on the cooling system 200, pressed to turn off the cooling system 200, optionally pressed to pair the cooling system 200 with a mobile electronic device, etc.). Optionally, the power switch can be located generally at the center of the end cap (e.g., so that it aligns/extends along the symmetrical axis of the container vessel 100).

[0072] FIG. 18 shows an example bottom view of the cooler container assembly 1000, showing the proximal vent openings 205B that communicate with the channels 206A, 206B of the air vent assemblies 202A, 202B. FIG. 18 also shows the electrical contacts 34 on the bottom surface 306 of the cooler container assembly 1000. In one example, the proximal vent openings 205B protrude from the bottom surface 306 of the assembly 1000, allowing them to extend into the corresponding proximal openings 205A on the top surface 302 of the assembly 1000. In one example, the electrical contacts 34 protrude from the bottom surface 306 of the assembly 1000, allowing them to extend into corresponding openings for the electrical contacts 32 on the top surface 302 of the assembly 1000.

[0073] FIG. 19 shows multiple cooler container assemblies 1000 stacked on top of each other. In one example, the bottom of the assemblies 1000 can be placed on a power base or charging base 500. The electrical contacts 32, 34 of the assemblies 1000 allows power to be transferred from one assembly 1000 to the assembly 1000 above it, allowing each of the assemblies 1000 in the stack to receive power from the single charging base 500, advantageously allowing the assemblies 1000 to be powered (e.g., their batteries charged) at the same time.

[0074] The charging base 500 can have a platform or base 510 optionally coupled to an electrical cord 512 (e.g., which can be connected to wall power or a portable power source, such as a power source in a trailer, truck, boat, airplane or other transportation unit). The base 510 can have one or more charging units 520 (e.g., two charging units 520A, 520B). The charging units 520 can optionally have one or more connectors 505 sized and/or shaped to interface with the proximal vent openings 205B. The charging units 520 can optionally have one or more electrical contacts 534 sized and/or shaped to interface with the electrical contacts 34 on the bottom of the cooler container assembly 1000. In one example, the connectors 505 and electrical contacts 534 can have a curved shape. In one example, the connectors 505 and electrical contacts 534 together generally define a circular shape (e.g., generally corresponding to a generally circular shape defined by the electrical contacts 34 and proximal vent openings 205B on the bottom surface 306 of the assembly 1000).

[0075] Optionally, the display 188 of each of the assemblies 1000 in the stack can display the charging status (e.g., % charge, charge level, time remaining during which cooling system 200 can operate, etc.) of one or more batteries in the corresponding assembly 1000. Optionally, the display 188 of each of the assemblies 1000 can indicate (e.g., via a visual and/or audio signal) when its corresponding batteries are fully charged.

[0076] Figure 20 shows a top surface 302 of the cooler container assembly 1000, which can optionally include an indicator light 195 to indicate one or more of: the assembly 1000 is on, the lid 400 is closed correctly (e.g., via a signal from one or more sensors, such as proximity sensors, capacitance sensors, etc. send to the control circuitry of the assembly 1000), and the cooling system 200 is in operation (e.g., to cool the chamber 126).

[0077] FIG. 21 shows a button 187 on a front of the assembly 1000 (e.g., located below the display 188). The button 187 can be actuated (e.g., by a user) to display the battery level of the assembly 1000 (e.g., % charge, charge level, time remaining during which cooling system 200 can operate, etc.). The button 187 can be located elsewhere on the assembly 1000. The button 187 can be a depressible button or a touch switch (e.g., capacitance) sensor.

[0078] FIG. 22 shows a block diagram of a control system for (e.g., incorporated into) the devices described herein (e.g., the cooler container assembly 1000, 1000', 1000'', 1000'''). In the illustrated embodiment, circuitry EM (e.g., control circuitry, microcontroller unit MCU, computer processor(s), etc.) can receive sensed information from one or more sensors S1-Sn (e.g., level sensors, volume sensors, temperature sensors, pressure sensors, orientation sensors such as gyroscopes, accelerometers, battery charge sensors, biometric sensors, load sensors, Global Positioning System or GPS sensors, radiofrequency identification or RFID reader, etc.).

[0079] In one implementation, at least one temperature sensor Sn (e.g., Sn1, Sn2 and/or Sn3) is in the vessel 100, 100', 100''' or lid 400, 400', 400''' and exposed to the chamber 126, 126''' to sense a temperature in the chamber 126, 126'''. In another implementation, additionally or alternatively, at least one temperature sensor Sn, Ta (see FIG. 27A) is on the vessel 100, 100', 100''' or lid 400, 400', 400''' and exposed to the outside of the container 1000, 1000', 1000'', 1000''' to measure ambient temperature. In one implementation, the RFID reader in the vessel 100, 100', 100''' or lid 400, 400', 400''' can read RFID tags of components (e.g., medication, vials, liquid containers, food packages) placed in the chamber 126, 126'''. The RFID reader can optionally log when the payload contents are inserted into the chamber 126, 126''', and additionally or alternatively the RFID reader can optionally log when each of the one or more of the payload contents is removed from the chamber 126, 126''' to track their position relative to the vessel 100, 100', 100''' and communicate this information to the circuitry EM (e.g., to a memory of the circuitry EM).

[0080] In one implementation, one or more of the sensors S1-Sn can include a pressure sensor. The pressure sensor can optionally sense ambient pressure, which can be

indicative of an altitude of the cooler container assembly 1000, 1000', 1000'', 1000'''. Optionally, the pressure sensor communicates sensed pressure information to the circuitry EM, which can optionally log or record the data from the pressure sensor and/or can operate one or more components of the cooling system 200, 200'', such as the TECs 220, 220'' and fan(s) 280, 280'' based at least in part on the sensed pressure information from the pressure sensor (e.g., to maintain the chamber 126, 126', 126'' at a desired temperature or temperature range). Such pressure sensor(s) can advantageously allow the cooling system 200, 200'' to operate such that the chamber 126, 126', 126'' is at a desired temperature or temperature range while the cooler container assembly 1000, 1000', 1000'', 1000''' is in transit (e.g., in high altitude locations), such as on an airplane or truck.

[0081] In one implementation, one or more of the sensors S1-Sn can include an accelerometer. The accelerometer can optionally sense motion (e.g., sudden movement) of the cooler container assembly 1000, 1000', 1000'', 1000'''. Optionally, the accelerometer communicates with the circuitry EM, which can optionally log or record the data from the accelerometer and/or can operate one or more components of the cooling system 200, 200'', such as the TECs 220, 220'' and fan(s) 280, 280'' based at least in part on the sensed information from the accelerometer. Such accelerometer(s) can advantageously sense, for example, when the cooler container assembly 1000, 1000', 1000'', 1000''' has been dropped (e.g., from an unsafe height) or experienced a shock, for example while in transit, such as on an airplane or truck. In one implementation, the accelerometer can also provide the circuitry EM with sensed orientation information of the cooler container assembly 1000, 1000', 1000'', 1000'''. In another implementation, a separate orientation sensor (e.g., a gyroscope), can sense an orientation of the cooler container assembly 1000, 1000', 1000'', 1000''' and communicate the sensed orientation information to the circuitry EM, which can optionally log or record the data from the orientation sensor and/or can operate one or more components of the cooling system 200, 200'', such as the TECs 220, 220'' and fan(s) 280, 280'' based at least in part on the sensed orientation information.

[0082] The circuitry EM can be housed in the container vessel 100. The circuitry EM can receive information from and/or transmit information (e.g., instructions) to one or more heating or cooling elements HC, such as the TEC 220 (e.g., to operate each of the

heating or cooling elements in a heating mode and/or in a cooling mode, turn off, turn on, vary power output of, etc.) and optionally to one or more power storage devices PS (e.g., batteries, such as to charge the batteries or manage the power provided by the batteries to the one or more heating or cooling elements).

[0083] Optionally, the circuitry EM can include a wireless transmitter, receiver and/or transceiver to communicate with (e.g., transmit information, such as sensed temperature and/or position data, to and receive information, such as user instructions, from one or more of: a) a user interface UI1 on the unit (e.g., on the body of the container vessel 100 or frame 300), b) an electronic device ED (e.g., a mobile electronic device such as a mobile phone, PDA, tablet computer, laptop computer, electronic watch, a desktop computer, remote server, cloud server), c) via the cloud CL, or d) via a wireless communication system such as WiFi, broadband network and/or Bluetooth BT. For example, the circuitry EM can have a cell radio antenna or cell radio via which it can communicate information (e.g., GPS location, sensed temperature in the chamber, ambient temperature, etc.) wirelessly (e.g., to the cloud CL, to a remote electronic device, such as a smartphone, etc.). A user can then track a location of the container 1000, 1000', 1000'', 1000''' (e.g., via a website or app on a smartphone). When the containers 1000, 1000', 1000'', 1000''' are stacked, they can set up a MESH network (e.g., a meshnet via BLE 5.0), which would allow the containers 1000, 1000', 1000'', 1000''' at the top of the stack to communicate (via the cell radio or cell radio antenna) GPS location and/or sensed temperature data for each of the stacked containers 1000, 1000', 1000'', 1000'''. For example, the MESH network can optionally identify the container 1000, 1000', 1000'', 1000''' with the most available power to communicate the GPS location and/or sensed temperature data. The electronic device ED can have a user interface UI2, that can display information associated with the operation of the cooler container assembly 1000, 1000', 1000'', 1000''', and that can receive information (e.g., instructions) from a user and communicate said information to the cooler container assembly 1000, 1000', 1000'', 1000''' (e.g., to adjust an operation of the cooling system 200).

[0084] In operation, the cooler container assembly 1000, 1000', 1000'' can operate to maintain the chamber 126 of the container vessel 100 at a preselected temperature or a user selected temperature. The cooling system can operate the one or more TECs 220,

220'' to cool the chamber 126, 126'' (e.g., if the temperature of the chamber is above the preselected temperature, such as when the ambient temperature is above the preselected temperature or temperature range, for example when transporting of medication in summer or to very hot climate location) or to heat the chamber 126, 126'' (e.g., if the temperature of the chamber 126 is below the preselected temperature, such as when the ambient temperature is below the preselected temperature or temperature range, for example when transporting of medication in winter or to very cold climate location).

[0085] In one implementation, the circuitry EM can reverse the polarity of the TECs 220, 220'' and operate the TECs 220, 220'' to heat the chamber 126, 126'' (e.g., by heating a fluid circulating via a conduit in thermal communication with a phase change material or thermal mass to heat it, which in turn heats the chamber 126, 126''). Advantageously, such reversing of the polarity of the TECs 220, 220'' to heat the chamber 126, 126'' (e.g., by heating of a phase changer material or thermal mass via thermal communication with a fluid heated by the TECs 220, 220'') inhibits (e.g., prevents) one or more of the payload components (e.g., medicine, vaccines, perishable liquids or solids) from freezing. For example, as ambient temperature approaches a predetermined temperature (e.g., 2 degrees C), for example as measured by a temperature sensor (e.g., Ta in FIG. 27A) of the cooler container assembly 1000, 1000', 1000'', the circuitry EM can reverse the polarity of the TECs 220, 220'' and operate them to heat the chamber 126, 126'' as discussed above. Once ambient temperature rises above a predetermined temperature (e.g., 3 degrees C), the circuitry EM can stop operation of the TECs 220, 220'' to heat the chamber 126, 126'' and/or reverse the polarity of the TECs 220, 220'' to their original state (e.g., a state in which the TECs 220, 220'' can operate to cool the chamber 126, 126'').

[0086] In one implementation, shown in FIG. 27B, the cooler container 1000'' can have one or more removable batteries PS'', which can be installed in the cooler container 1000'' (e.g., via opening 305'') to power the TECs 220, 220'' in the reversed polarity state to heat the chamber 126, 126''. The circuitry EM and TECs 220, 220'' can be operated with power from the one or more removable batteries PS'', instead of other batteries (PS, PS'), which power other components of the cooler container assembly 1000, 1000', 1000'' when the circuitry EM needs to operate the TECs 220 to heat the chamber 126, 126'' (e.g., when

sensed ambient and/or chamber temperature falls below a predetermined temperature). Advantageously, to reduce the shipping weight of the cooler container assembly 1000, 1000', 1000'', 1000''', the one or more batteries PS'' can optionally only be installed in the cooler container assembly 1000, 1000', 1000'', 1000''' when they are to be shipped to a climate where ambient temperature is likely to drop below a first predetermined temperature (e.g. 2 degrees C) and/or when they are to be shipped to a climate where ambient temperature is likely to increase above a second predetermined temperature (e.g., 15 degrees C, 20 degrees C, 30 degrees C, etc.). In another implementation, the one or more batteries PS'' can be installed in the cooler container assembly 1000, 1000', 1000'', 1000''' for all shipments, irrespective of expected ambient temperature.

[0087] In some implementations, the cooler container assembly 1000, 1000', 1000'', 1000''' can have a separate heater unit (e.g., resistive heater) in thermal communication with the chamber 126, 126''' (e.g., wound at least partially about the chamber 126, 126'''), which can be operated when the ambient temperature is above the preselected temperature in the chamber 126, 126''' (e.g., after a predetermined period of time), such as when transporting medication in winter or to a very cold climate location). Optionally, the separate heater unit (e.g., resistive heater) and/or circuitry EM can be powered by the one or more batteries PS''. The preselected temperature may be tailored to the contents of the container (e.g., a specific medication, a specific vaccine, food, beverages, human tissue, animal tissue, living organisms), and can be stored in a memory of the assembly 1000, and the cooling system or heating system, depending on how the temperature control system is operated, can operate the TEC 220 to approach the preselected or set point temperature.

[0088] Optionally, the circuitry EM of the cooler container 1000, 1000', 1000'', 1000''' can communicate (e.g., wirelessly) information to a remote location (e.g., cloud based data storage system, remote computer, remote server, mobile electronic device such as a smartphone or tablet computer or laptop or desktop computer) and/or to the individual carrying the container (e.g., via their mobile phone, via a visual interface on the container, etc.), such as a temperature history of the chamber 126 to provide a record that can be used (e.g., to evaluate the efficacy of the medication in the container, to evaluate if contents in the chamber 126 have spoiled, etc.) and/or alerts on the status of the chamber 126 and/or

contents in the chamber 126. Optionally, the temperature control system (e.g., cooling system, heating system) of the cooler container 1000, 1000', 1000'' automatically operates the TEC 220 to heat or cool the chamber 126 of the container vessel 100 to approach the preselected temperature. In one implementation, the cooling system 200 can cool and maintain one or both of the chamber 126 and the contents therein at or below 15 degrees Celsius, such as at or below 10 degrees Celsius (e.g., in the range of 2 degrees Celsius to 8 degrees Celsius), in some examples at approximately 5 degrees Celsius.

[0089] In one implementation, the one or more sensors S1-Sn can include one more air flow sensors that can monitor airflow through one or both of the intake vent 203 and exhaust vent 205, through the cold side fluid chamber 215, inlet line 140 and/or outlet line 150. If said one or more flow sensors senses that the intake vent 203 is becoming clogged (e.g., with dust) due to a decrease in air flow, the circuitry EM (e.g., on the PCBA) can optionally reverse the operation of the fan 280 for one or more predetermined periods of time to draw air through the exhaust vent 205 and exhaust air through the intake vent 203 to clear (e.g., unclog, remove the dust from) the intake vent 203. In another implementation, the circuitry EM can additionally or alternatively send an alert to the user (e.g., via a user interface on the assembly 1000, wirelessly to a remote electronic device such as the user's mobile phone) to inform the user of the potential clogging of the intake vent 203, so that the user can inspect the assembly 1000 and can instruct the circuitry EM (e.g., via an app on the user's mobile phone) to run a "cleaning" operation, for example, by running the fan 280 in reverse to exhaust air through the intake vent 203. In one example, an air filter can optionally be placed underneath the intake grill/vent 203.

[0090] In one implementation, the one or more sensors S1-Sn of the cooler container 1000, 1000', 1000'', 1000''' can include one more Global Positioning System (GPS) sensors for tracking the location of the cooler container assembly 1000, 1000', 1000'', 1000'''. The location information can be communicated, as discussed above, by a transmitter (e.g., cell radio antenna or cell radio) and/or transceiver associated with the circuitry EM to a remote location (e.g., a mobile electronic device, a cloud-based data storage system, etc.). In one implementations, the GPS location is communicated (e.g., automatically, not in response to a query or request) by the circuitry EM at regular intervals (e.g., every 10 minutes, every

15 minutes, etc.). In another implementation, the GPS location is communicated by the circuitry EM upon receipt of a request or query, such as from the user (e.g., via an app or website via which the user can track the location of the cooler container 1000, 1000', 1000'', 1000''').

[0091] Figure 23 shows a block diagram of electronics 180 of the cooler container assembly 1000, 1000', 1000'', 1000'''. The electronics 180 can include circuitry EM' (e.g., including one or more processors on a printed circuit board). The circuitry EM' communicate with one or more batteries PS', with the display screen 188, 188''', and with the user interface 184, 184'''. Optionally, a memory module 185 is in communication with the circuitry EM'. In one implementation, the memory module 185 can optionally be disposed on the same printed circuit board as other components of the circuitry EM'. The circuitry EM' optionally controls the information displayed on the display screen 188, 188'''. Information (e.g., sender address, recipient address, etc.) can be communicated to the circuitry EM' via an input module 186. The input module 186 can receive such information wirelessly (e.g., via radiofrequency or RF communication, via infrared or IR communication, via WiFi 802.11, via BLUETOOTH®, etc.), such as using a wand (e.g., a radiofrequency or RF wand that is waved over the container assembly 1000, 1000', 1000'', 1000''', such as over the display screen 188, 188''', where the wand is connected to a computer system where the shipping information is contained). Once received by the input module 186, the information (e.g., shipping information for a shipping label to be displayed on the display screen 188 can be electronically saved in the memory module 185). Advantageously, the one or more batteries PS' can power the electronics 180, and therefore the display screen 188 for a plurality of uses of the cooler container assembly 1000, 1000', 1000'', 1000'''' (e.g., during shipping of the container assembly 1000 up to one-thousand times). As discussed above, the electronics 180 can wirelessly communicate a signal to a shipping carrier (e.g., UPS, FedEx, DHL) informing the shipping carrier that a shipping label (e.g., new shipping label) has been assigned to the portable cooler and that the cooler is ready for pick-up and shipping (e.g., when the user interface 184 is actuated by the user).

[0092] Figure 24A shows a block diagram of one method 800 for shipping the cooler container assembly 1000, 1000', 1000'', 1000'''. At step 810, one or more

components (e.g., food(s), beverage(s), medicine, living tissue or organisms) are placed in the container vessel 100 of the container assembly 1000, such as at a distribution facility for the components or products. At step 820, the lid 400 is closed over the container vessel 100 once the contents have been placed therein. Optionally, the lid 400 is locked to the container vessel 100, 100', 100'' (e.g., via a magnetically actuated lock, including an electromagnet actuated when the lid 400 is closed that can be turned off with a code, such as a digital code, a code provided to a user's phone, etc.). At step 830, information (e.g., shipping label information) is communicated (e.g., loaded onto) to the container assembly 1000. For example, as discussed above, a radiofrequency (RF) wand can be waved over the container assembly 1000, 1000', 1000'', 1000''' to transfer the shipping information to the input module 186 of the electronics 180 of the container assembly 1000, 1000', 1000'', 1000'''. At step 780, the container assembly 1000, 1000', 1000'', 1000''' is shipped to the recipient (e.g., displayed on the shipping label 189 on the display screen 188).

[0093] Optionally, the assemblies 1000, 1000', 1000'', 1000''' can be stacked, for example on a pallet P, as shown in FIG. 16, allowing hot air to be exhausted from the stacked assemblies 100 (using a chimney effect) as discussed above, allowing heated air to exit the stacked assemblies and, for example, be vented out of the shipping container via one or more vents in the shipping container. Further, as discussed above, the stacked assemblies 1000, 1000', 1000'', 1000''' can be electrically connected, allowing power transfer between a lower assembly 1000, 1000', 1000'', 1000''' to a higher assembly 1000, 1000', 1000'', 1000''' (e.g., when all the assemblies are stacked on a power base or a charging base, such as prior to shipping in a warehouse or distribution center or during shipping if the shipping container has a power or charging base on which the assemblies 1000 are stacked). The assemblies 1000, 1000', 1000'', 1000''' within the stack (see FIGS. 16, 19) can establish two-way communication link to transmit data, for example temperature history and battery consumption data. In one example, where one of the cooler container assemblies 1000, 1000', 1000'', 1000''' is low on power, it can optionally draw power from one or more of the assemblies 1000 around it (e.g., above it, below it) when stacked. Cooling system 200 in individual cooler container assemblies 1000 can optionally remain active when assemblies 1000 are stacked on a power base or charging base (such as charging base 500 in FIG. 19) to

charge PCM 135 simultaneously, for example, at the warehouse or shipping facility, on a truck, ship, airplane, etc.

[0094] Figure 24B shows a block diagram of a method 800' for returning the container assembly 1000, 1000', 1000'', 1000'''. At step 850, after receiving the container assembly 1000, 1000', 1000'', 1000''', the lid 400, 400'' can be opened relative to the container vessel 100. Optionally, prior to opening the lid 400, 400'', the lid 400, 400'' is unlocked relative to the container vessel 100 (e.g., using a code, such as a digital code or RFID code on user's mobile phone, provided to the recipient from the shipper, via a keypad on the vessel 100, 100', 1000'' or lid 400, 400'', 400''' and/or biometric identification). The user's smartphone or other electronic device with the unlock code can be communicated to the container 1000, 1000', 1000'', 1000''', for example, via Bluetooth or RFID, to unlock the lid 400, 400'', 400''' from the vessel 100, 100', 100''' (e.g., by positioning or waving the smartphone or electronic device near the vessel and/or lid). At step 860, the contents (e.g., medicine, foodstuff, beverages, living organisms or tissue) are removed from the container vessel 100. At step 870, the lid 400 is closed over the container vessel 100. At step 880, the user interface 184 (e.g., button) is actuated to switch the information of the sender and recipient in the display screen 188 with each other, advantageously allowing the return of the container assembly 1000, 1000', 1000'', 1000''' to the original sender to be used again without having to reenter shipping information on the display screen 188, 188'''. Optionally, actuation of the user interface 184, 184''' in step 880 causes a signal to be wirelessly communicated (e.g., by the electronics 180) to a shipping carrier (e.g., UPS, FedEx, DHL) informing the shipping carrier that a shipping label (e.g., new shipping label) has been assigned to the portable cooler and that the cooler is ready for pick-up and shipping. In one example, the cooler container assembly 1000, 1000', 1000'', 1000''' or stack of assemblies 1000, 1000', 1000'', 1000''' can also send notifications to both end-user as well as origin facility during certain events, for example, payload has been delivered or alerts as needed.

[0095] The display screen 188, 188''' and label 189 advantageously facilitate the shipping of the container assembly 1000 without having to print any separate labels for the container assembly 1000. Further, the display screen 188, 188''' and user interface 184, 184''' advantageously facilitate return of the container system 1000 to the sender (e.g.

without having to reenter shipping information, without having to print any labels), where the container assembly 1000, 1000', 1000'', 1000''' can be reused to ship contents again, such as to the same or a different recipient. The reuse of the container assembly 1000, 1000', 1000'', 1000''' for delivery of perishable material (e.g., medicine, food, beverages, living tissue or organisms) advantageously reduces the cost of shipping by allowing the reuse of the container vessel 100 (e.g., as compared to commonly used cardboard containers, which are disposed of after one use).

[0096] Figure 25 shows a partially exploded view of a cooler container 1000'. Some of the features of the cooler container 1000' are similar to features of the cooler container 1000 in FIGS. 1-24B. Thus, reference numerals used to designate the various components of the cooler container 1000' are identical to those used for identifying the corresponding components of the cooler container 1000 in FIGS. 1-24B, except that a " ' " has been added to the numerical identifier. Therefore, the structure and description for the various features of the cooler container 1000 and how it's operated and controlled in FIGS. 1-24B are understood to also apply to the corresponding features of the cooler container 1000' in FIG. 25, except as described below. Though the features below are described in connection with the cooler container assembly 1000', the features also apply to all cooler containers, such as cooler containers 1000, 1000'', 1000''' disclosed herein.

[0097] The cooler container 1000' differs from the cooler container 1000 in that the one or more power storage devices (e.g., batteries) PS, PS' are in a module 350' that can be removably coupled to the cooler container 1000'. In one implementation, the power storage devices PS, PS' can optionally be arranged in one or more stacks on a platform 352', and electrically connected to the electrical contacts 34' underneath the platform 352'. The module 350' can optionally couple to the cooler container 1000' (e.g., to the frame 300' of the cooler container 1000') so that the power storage devices PS, PS' extend into compartments in the cooler container 1000' (e.g., compartments in the frame 300'), and so that the platform 352' is adjacent to or generally co-planar with the bottom surface 306' of the frame 300'.

[0098] The module 350' locks into place on the cooler container 1000' (e.g., via a latch mechanism, such as a spring-loaded latch mechanism, threaded coupling, magnetic

coupling, etc.). Once the module 350' is coupled to the cooler container 1000' (e.g., locked into place on the cooler container 1000', the display 188' can optionally register (e.g., display) that the module 350' is coupled and optionally show the charge level of the power storage devices PS, PS' of the module 350'. Power can be provided from the power storage devices PS, PS' to the electronics (e.g., Peltier element 220, fan 280, circuitry EM) in the cooler container 1000', for example, via electrical contacts between the module 350' and the cooler container 1000' (e.g., electrical contacts on the frame 300' that contact electrical contacts of the module 350'). In another implementation, power is transmitted from the power storage devices PS, PS' in the module 350' to the electronics (e.g., Peltier element 220, fan 280, circuitry EM) in the cooler container 1000' via inductive coupling.

[0099] Advantageously, the module 350' can be decoupled and removed from the cooler container 1000' to replace the power storage devices PS, PS', or to replace the module 350'. Therefore, the module 350' can be interchangeable and/or replaceable. The power storage devices (e.g., batteries) PS, PS' in the module 350' can optionally be charged (or recharged) while coupled to the cooler container 1000'. In another implementation, the module 350' can be detached from the cooler container 1000' and charged (or recharged) separately on the charging station or base 500 before being coupled to the cooler container 1000' as discussed above.

[0100] Figure 26 shows a schematic view of a cooler container 1000''. Some of the features of the cooler container 1000'' are similar to features of the cooler container 1000 in FIGS. 1-24B and cooling container 1000' in FIG. 25. Thus, reference numerals used to designate the various components of the cooler container 1000'' are identical to those used for identifying the corresponding components of the cooler container 1000 in FIGS. 1-24B and cooler container 1000' in FIG. 25, except that a “ ” has been added to the numerical identifier. Therefore, the structure and description for the various features of the cooler container 1000'' and how it's operated and controlled in FIGS. 1-25 are understood to apply to the corresponding features of the cooler container 1000'' in FIG. 26, except as described below. Though the features below are described in connection with the cooler container assembly 1000'', the features also apply to all cooler containers, such as cooler containers 1000', 1000, disclosed herein.

[0101] The cooler container 1000'' can have one or more sleeve portions 130'' disposed about the chamber 126'' of the container 1000'' that can be filled with temperature sensitive contents (e.g., medicine, vaccines, tissue). The sleeve portion(s) 130'' can optionally be discrete volumes disposed about the chamber 126''. The sleeve portion(s) 130'' can house a phase change material (PCM) or thermal mass 135'' therein. In one implementation, the phase change material 135'' can be a solid-liquid PCM. In another implementation, the phase change material 135'' can be a solid-solid PCM. The PCM 135'' advantageously can passively absorb and release energy. Examples of possible PCM materials are water (which can transition to ice when cooled below the freezing temperature), organic PCMs (e.g., bio based or Paraffin, or carbohydrate and lipid derived), inorganic PCMs (e.g., salt hydrates), and inorganic eutectics materials. However, the PCM 135'' can be any thermal mass that can store and release energy.

[0102] The cooler container 1000'' can optionally include a cooling system 200''. In other examples, described below, at least a portion of the cooling system 200'' can be external to the container 1000''. The cooling system 200'' is optionally a closed loop system. The cooling system 200'' optionally includes a conduit 140'' via which a cooling fluid (e.g., a cooling liquid, such as water) flows. In some implementations, the cooling fluid can be water. In some implementations, the cooling fluid can be a water mixture (e.g., a water-alcohol mixture, a mixture of water and ethylene glycol, etc.). The cooling system 200'' can optionally include one or more of a first heat sink 210'' (e.g., a solid to liquid heat exchanger), thermoelectric module(s) or TEC(s) 220'', a second heat sink 230'', fan(s) 280'', a pump 146'' and a reservoir 148''. The conduit 140'' can include a first conduit 140A'' that extends between the first heat sink 210'' and the sleeve portion(s) 130''. The conduit 140'' also includes a second conduit 140B'' that extends through the sleeve portion(s) 130'' and is in fluid communication with the first conduit 140A''. The reservoir 148'' is in fluid communication with an opposite end of the second conduit 140B''. The conduit 140'' also includes a third conduit 140C'' that extends between the reservoir 148'' and the pump 146''. The conduit 140'' also includes a fourth conduit 140D'' that extends between the pump 146'' and the first heat sink 210''.

[0103] In operation, the TEC(s) 220'' are operated (as described above in connection with the cooling container 1000, 1000') to remove heat from the first heat sink 210'' and transfer said heat to the second heat sink 230''. The fan(s) 280'' are optionally operated to dissipate the heat from the second heat sink 230'', thereby allowing the TEC(s) 220'' to remove additional heat from the first heat sink 210'' (e.g., to cool the first heat sink 210''). Optionally, the first heat sink 210'' (e.g., solid to liquid heat exchanger) can at least partially define one or more flow paths (e.g., in the body of the heat sink 210'') in fluid communication with the first conduit 140A'' and fourth conduit 140D''. The pump 146'' can be selectively operated (e.g., by a controller of the cooling system 200'' or container 1000'') to flow the cooling fluid (e.g., liquid) through the conduit 140'' and past or through the first heat sink 210'' where the cooling fluid is cooled. The cooled cooling fluid is then directed through the first conduit 140A'' and into the sleeve(s) 130'' via the second conduit 140B'' where the cooling fluid removes heat from the PCM 135'' to thereby charge the PCM 135'' (e.g., to place the PCM 135'' in a state where it can absorb energy). The fluid then exits the sleeve(s) 130'' and flows into the reservoir 148''. From the reservoir 148'', the fluid flows via the third conduit 140C'' to the pump 146'', where the pump 146'' again pumps the liquid via the fourth conduit 140D'' past or through the first heat sink 210''.

[0104] Advantageously, the cooling fluid (e.g., liquid) rapidly cools the PCM 135'' in the sleeve(s) 130'' to charge the PCM 135''. Optionally, the second conduit 140B'' in the sleeve(s) 130'' extends in a coil like manner (e.g., in a spiral manner) through the sleeve(s) 130'' to thereby increase the surface area of the second conduit 140B'' that contacts the PCM 135'', thereby increasing the amount of heat transfer between the cooling fluid and the PCM 135''. This configuration of the second conduit 140B'' advantageously results in more rapid cooling/charging of the PCM 135''. In one example, the chamber 126'' of the cooler container 1000'' can be cooled to between about 2 and about 8 degrees Celsius (e.g., 0 degrees C, 1 degree C, 2 degrees C, 3 degrees C, 4 degrees C, 5 degrees C, 6 degrees C, 7 degrees C, 8 degrees C, 9 degrees C, 10 degrees C, etc.). Optionally, the reservoir 148'' can have a valve (e.g., bleed valve) via which cooling fluid can be bled from the cooling system 200'' or via which cooling fluid can be introduced into the cooling system 200''.

[0105] The cooler container 1000'' can optionally exclude batteries and electronics, such that the cooling system 200'' does not operate while the cooler container 1000'' is in transit (e.g., on a trailer, truck, airplane, boat, car, etc.). Rather, while in transit, the chamber 126'' of the cooler container 1000'' is cooled by the charged PCM 135'' (e.g., the PCM 135'' is the primary cooling mechanism for the chamber 126''). The cooling system 200' can be optionally be operated when the cooler container 1000'' is placed on a power base (e.g., at a home shipping location, at a hospital, etc.). For example, the cooler container 1000'' can have electrical contacts that selectively contact electrical contacts on a power base when the cooler container 1000'' is placed on the power base. The power base provides power to one or more of the TEC(s) 220'', pump 146'', and fan(s) 280'', which operate (e.g., by circuitry in the container 1000'') as described above to charge the PCM 135''. Once the PCM 135'' is charged, the cooler container 1000'' can be removed from the power base and the chamber 126'' filled with temperature sensitive contents (e.g., medicine, vaccines, tissue, etc.), and the cooler container 1000'' can be shipped to its destination, as described above. The charged PCM 135'' can operate to maintain the contents in the chamber 126'' in a cooled state during transit of the cooler container 1000'' to its destination.

[0106] As discussed above, the cooler containers 1000'' can optionally be stacked on top of each other, with the bottom cooler container 1000'' disposed on the power base, so that power is transferred from the power base up through the stack of cooler containers 1000'' (e.g., the PCM 135'' in all stacked containers 1000'' are charged substantially simultaneously). In one example, each cooler container 1000'' has an amount of cooling fluid in its closed loop cooling system 200'' and power is transferred from each container 1000'' to the one above it to operate its cooling system 200'' to charge its PCM 135''. However, this requires that each container 1000'' have an amount of cooling fluid in it at all times.

[0107] In another example, the cooler container(s) 1000'' can optionally have quick disconnect connections that allow for the conduit 140'' of each stacked container 1000'' to be in fluid communication with each other when the containers 1000'' are stacked (e.g., each container 1000'' has an open loop cooling system). In this example, the cooling system 200'' (e.g., including the first heat sink 210'', TEC(s) 220'', second heat sink 230'',

fan(s) 280'', pump 146'' and reservoir 148'') can be located in communication or housed in the power base, not in a vessel 100'' of the cooler container(s) 1000''. The power base can have quick disconnect connectors that removably couple with quick disconnect connectors on the container 1000'' that is connected to the power base (e.g., quick disconnect connectors between different sections of the conduit 140'', where some sections, such as 140A'', 140C'', 140B'' are outside the container 1000'' and only conduit section 140B'' is in the container 1000''), and each container 1000'' can have quick disconnect connectors or valves that allow it to fluidly connect with a container 1000'' placed on top of it (e.g., allow the conduit 140'' of a container to fluidly connect with the conduit 140'' of the container 1000'' placed on top of it). Advantageously, this allows the PCM 135'' in each of the stacked containers 1000'' to be charged at the same time, and allows the reduction in weight and/or size of the cooler container 1000'' (e.g., because the cooling system 200'' and the cooling fluid is not housed in the container 1000'' during transit of the container 1000''), thereby reducing freight cost of shipping the cooling container 1000''.

[0108] Figures 27A-27B show a schematic view of a variation of the cooling container 1000''. FIGS. 27A-B add fins 149'' to the second conduit 140B'' in the sleeve(s) 130'' (e.g., the fins 149'' would extend between walls of the sleeve(s) 130''), thereby increasing the surface area that is in contact with the PCM 135'' and via which heat can be transferred between the PCM 135'' and the second conduit 140B'' to allow the cooling fluid to charge the PCM 135''. Though the features below are described in connection with the cooler container assembly 1000'', the features also apply to all cooler containers, such as cooler containers 1000', 1000'', disclosed herein.

[0109] The container 1000'' can have one or more temperature sensors Sn1 in communication with the conduit 140'' (e.g., with the conduit section 140B''), one or more temperature sensors Sn2 in communication with the chamber 126'', and/or one or more temperature sensors Sn3 in the sleeve(s) 130'' (e.g., in thermal communication with the PCM 135''). The one or more temperature sensors Sn1, Sn2, Sn3 can communicate with the circuitry EM, and the circuitry EM can operate one or both of the TEC(s) 220'' and fan(s) 280'' based at least in part on the sensed temperature from the sensors Sn1, Sn2, and/or Sn3. The container 1000'' can optionally have one or more sensors Ta that sense ambient

temperature and communicate with the circuitry EM. The sensed temperature from the sensor Ta can provide an indication of humidity level to the circuitry EM, and the circuitry EM can operate one or both of the TEC(s) 220'' and fan(s) 280'' based at least in part on the sensed temperature from the sensor(s) Ta. The cooler container 1000'' can optionally have a shutoff valve 147'', which can be selectively actuated by the circuitry EM to inhibit (e.g., prevent) flow of liquid through the conduit 140'' (e.g., when there is a malfunction in a component of the cooler container 1000'', such as the pump 146'' or TEC(s) 220'').

[0110] With reference to FIG. 27B, air can enter the vessel 100'' via one or more air intake openings 203'', and be driven by one or more fans 280'' through a channel or path 215'' and past a first heat sink 230'', where heat is transferred from the first heat sink 230'' to the air. The air is then exhausted from the vessel 100'' via one or more exhaust openings 205''. Though FIG. 27B shows the intake openings 203'' and exhaust openings 205'' in the same plane or surface, in other implementations, the intake openings 203'' and exhaust openings 205'' can be on separate planes (e.g., separate planes oriented 180 degrees apart, separate planes oriented 90 degrees apart). For example, the exhaust openings 205'' can be on a front surface of the container 1000'' (e.g., a surface that has the display of the container 1000'') and the intake openings 203'' can be on a rear surface of the container 1000'' orientated 180 degrees apart. In another implementation, the exhaust openings 205'' can be on a rear surface of the container 1000'' and the intake openings 203'' can be on a front surface of the container 1000'' (e.g., a surface that has the display of the container 1000'') orientated 180 degrees apart.

[0111] Optionally, the cooling system can be located in one corner (e.g., along one edge) of the cooler container 1000'', as shown in FIG. 27B. In another implementation, the cooling system can be distributed about at least a portion of the chamber 126'' (e.g., distributed completely about the chamber 126''). The first heat sink 230'' is in thermal communication with one or more TEC(s) 220'', which are in turn in thermal communication with a second heat sink 210'' (e.g., a solid to liquid heat exchanger). The second heat sink 210'' is in thermal communication with the conduit 140'', which flow a fluid (e.g., a liquid, such as water) therethrough. The second heat sink 210'' cools the fluid in the conduit 140'' as it flows past the second heat sink 210'', and transfers the heat to the TECs 220'', which in

turn transfers the heat to the first heat sink 230'' that in turn transfers the heat to the air that is exhausted via the exhaust opening(s) 205''. The cooled liquid in the conduit 140'' charges the PCM 135'' in the sleeve portion(s) 130'' via the fins 149'' (e.g., so that the phase change material or PCM 135'' is in a state where it can absorb energy, such as to cool at least a portion of the chamber 126''). FIG. 27C show another implementation of the cooler container 1000'' with the one or more removable batteries PS'' that can be optionally installed to power one or both of the circuitry EM and TEC's 220, 220'' or separate heater, as discussed above, to inhibit (e.g., prevent) one or more of the payload contents from freezing in cold weather or from exposure to high temperatures in hot weather.

[0112] Figure 28 is a schematic view of a variation of the cooler container 1000'' in FIG. 26. The structure and description for the various features of the cooler container 1000'' and how it's operated and controlled in FIGS. 1-26 are understood to apply to the corresponding features of the cooler container 1000'' in FIG. 28, except as described below. Whereas FIG.26 shows the second conduit 140B'' oscillating horizontally, FIG. 28 shows the second conduit 140B''' oscillating vertically within the sleeve(s) 130''. Though the features below are described in connection with the cooler container assembly 1000'', the features also apply to all cooler containers, such as cooler containers 1000', 1000'', disclosed herein.

[0113] Figure 29 is a schematic view of a variation of the cooler container 1000'' in FIGS. 27A-B. The structure and description for the various features of the cooler container 1000'' and how it's operated and controlled in FIGS. 1-27B are understood to apply to the corresponding features of the cooler container 1000'' in FIG. 29, except as described below. Whereas FIGS. 27A-B shows the second conduit 140B'' with fins 149'' disposed about the conduit 140B'' oscillating horizontally, FIG. 29 shows the second conduit 140B''' with fins 149''' disposed about the conduit 140B''' oscillating vertically within the sleeve(s) 130''. Though the features below are described in connection with the cooler container assembly 1000'', the features also apply to all cooler containers, such as cooler containers 1000', 1000'', disclosed herein.

[0114] Figure 30 is a schematic view of a variation of the cooler container 1000'' in FIG. 26. The structure and description for the various features of the cooler container 1000'' and how it's operated and controlled in FIGS. 1-26 are understood to apply to the

corresponding features of the cooler container 1000'' in FIG. 31, except as described below. Unlike the second conduit 104B'' in FIG. 26, the second conduit 140B'''' extends in a spiral manner within the sleeve(s) 130'' (where the sleeve 130'' is excluded to more clearly show the shape of the conduit 140B''). Though the features below are described in connection with the cooler container assembly 1000'', the features also apply to all cooler containers, such as cooler containers 1000', 1000'', disclosed herein.

[0115] Figure 31 is a schematic view of a variation of the cooler container 1000'' in FIG. 26. The structure and description for the various features of the cooler container 1000'' and how it's operated and controlled in FIGS. 1-26 are understood to apply to the corresponding features of the cooler container 1000'' in FIG. 31, except as described below. Unlike the second conduit 140B'' in FIG. 26, The second conduit 140B'''' extends in a horizontal oscillating manner within the sleeve(s) 130'' (where the sleeve 130'' is excluded to more clearly show the shape of the conduit 140B''). Fins 149'''' are disposed about the conduit 140B'''' to aid in heat dissipation as discussed above. The second conduit 140B'''' extends between an inlet IN and an outlet OUT. Though the features below are described in connection with the cooler container assembly 1000'', the features also apply to all cooler containers, such as cooler containers 1000', 1000'', disclosed herein.

[0116] Figure 32 is a schematic view of a variation of the cooler container 1000'' in FIG. 28. The structure and description for the various features of the cooler container 1000'' and how it's operated and controlled in FIGS. 1-28 are understood to apply to the corresponding features of the cooler container 1000'' in FIG. 32, except as described below. Unlike the cooler container 1000'' in FIG. 28, FIG. 32 adds fins 131 that extend from an outer surface of the sleeve(s) 130'' to an outer wall (e.g., fourth wall) 104'. Though the features below are described in connection with the cooler container assembly 1000'', the features also apply to all cooler containers, such as cooler containers 1000', 1000'', disclosed herein.

[0117] Figure 33 shows a schematic cross-sectional view of a cooler container 1000'''. Some of the features of the cooler container 1000''' are similar to features of the cooler container 1000 in FIGS. 1-24B. Thus, reference numerals used to designate the various components of the cooling container 1000''' are identical to those used for

identifying the corresponding components of the cooling container 1000 in FIGS. 1-24B, except that a “ ’ ’ ” has been added to the numerical identifier. Therefore, the structure and description for the various features of the cooling container 1000 and how it's operated and controlled in FIGS. 1-24B are understood to also apply to the corresponding features of the cooling container 1000'’ in FIG. 33, except as described below. Though the features below are described in connection with the cooler container assembly 1000'’, the features also apply to all cooler containers, such as cooler containers 1000, 1000'’, disclosed herein.

[0118] The cooler container 1000'’ differs from the cooler container 1000 in various ways. For example, the cooler container 1000'’ does not include any fans (such as the fan 280), nor any air intake openings (such as the intake openings 203). The cooler container 1000'’ also does not include any thermoelectric modules or TECs (such as Peltier elements 220). Additionally, the cooler container 1000'’ does not include a flow pathway for flowing air or another fluid through the container to cool the container. Though FIG. 33 shows a cross-section of the container 1000'’, one of skill in the art will recognize that the container 1000'’ in one implementation is symmetrical about the cross-sectional plane (e.g. the container has a generally box-like or cube outer shape, such as with a square cross-section along a transverse plane to the cross-sectional plane in FIG. 33), which can advantageously maximize the number of containers 1000'’ that can be stored in a given volume (e.g., a delivery truck). The container 1000'’ can have other suitable shapes (e.g., cylindrical, rectangular, etc.).

[0119] The cooler container 1000'’ has a vessel 100'’ an outer housing 102'’. Optionally, the outer housing 102'’ has one or more portions. In the illustrated implementation, the outer housing 102'’ optionally has two portions, including a first (e.g., outer) portion 102A'’ and a second (e.g., inner) portion 102B'’. In other implementations, the outer housing 102'’ can have fewer (e.g., one) or more (e.g., three, four, etc.) portions.

[0120] The first portion 102A'’ optionally provides an outer shell. As shown in FIG. 33, the first portion 102A'’ optionally covers at least some (e.g., but not all) of the outer surface of the container 1000'’. For example, in one implementation, the first portion 102A'’ covers at least the edges of the container 1000'’. In one implementation, the first portion 102A'’ only covers the edges of the container 1000'’. In one implementation, the

first portion 102A''' is made of an impact resistant material, such as plastic. Other suitable materials can be used. In another implementation, the first portion 102A''' can additionally or alternatively be made of a thermally insulative material.

[0121] The second portion 102B''' is optionally made of a thermally insulative material, such as a foam material. Other suitable materials can be used. In another implementation, the second portion 102B''' can additionally or alternatively be made of an impact resistant (e.g., compressible) material.

[0122] In some implementations, the outer housing 102''' includes only the first portion 102A''' (e.g., the housing 102''' is defined only by the first portion 102A''') and excludes the second portion 102B'''. In some implementations, the outer housing 102''' includes only the second portion 102B''' (e.g., the housing 102''' is defined only by the second portion 102B''') and excludes the first portion 102A'''.

[0123] The container 1000''' also includes a vacuum insulated chamber 107''' defined between an outer wall 106A''' and an inner wall 106B''' (e.g., a double-walled insulated chamber), where the walls 106A''', 106B''' extend along the circumference and base of the chamber 126''' of the container 1000'''. Therefore, the chamber 126''' that receives the perishable contents (e.g., medicine, food, other perishables, etc.) is surrounded about its circumference and base by the vacuum insulated chamber 107''', which inhibits (e.g., prevents) heat transfer (e.g., loss of cooling) from the chamber 126''' via its circumference or base.

[0124] The cooler container 1000''' optionally includes a phase change material 135''' that can be disposed in the container 1000'''. In one implementation, the phase change material (PCM) 135''' or thermal mass is provided (e.g., contained) in a sleeve 130''' that is surrounded by the inner wall 106B''' and that defines an inner wall 126A''' of the chamber 126'''. In another implementation, the phase change material or thermal mass can alternatively be disposed in one or more packs (e.g., one or more ice packs) in the chamber 126''', where the chamber 126''' is defined by the inner wall 106B'''. In another implementation, the phase change material 135''' or thermal mass can be provided in a sleeve 130''' as well as in separate pack(s) (e.g., one or more ice packs) inserted into the chamber 126''' (e.g., about the perishable contents).

[0125] The chamber 126''' can be sealed with a lid 400'''. Optionally, the lid 400''' includes at least a portion 410''' made of a thermally insulative material (e.g., a foam material) to inhibit (e.g., prevent) heat transfer (e.g., loss of cooling) from the chamber 126''' via the opening in the top of the container 1000''' that is sealed with the lid 400'''. The lid 400''' optionally includes a double-walled vacuum insulated structure 420''' that at least partially surrounds (e.g., surrounds an entirety of) a sidewall and a top wall of the portion 410''' of thermally insulative material, which can further inhibit (e.g., prevent) loss of cooling from the chamber 126'''. In another implementation, the lid 400''' can optionally be hollow and have a space into which a phase change material can be inserted to further reduce the heat transfer out of the chamber 126'''.

[0126] The container 1000''' includes an electronic display screen 188''' (e.g., on a side surface, on a top surface, of the container 1000'''). The display screen 188''' can optionally be an electronic ink or E-ink display (e.g., electrophoretic ink display). In another implementation, the display screen 188''' can be a digital display (e.g., liquid crystal display or LCD, light emitting diode or LED, etc.). Optionally, the display screen 188''' can display a label, as shown in FIG. 15, (e.g., a shipping label with one or more of an address of sender, an address of recipient, a Maxi Code machine readable symbol, a QR code, a routing code, a barcode, and a tracking number), but can optionally additionally or alternatively display other information (e.g., temperature history information, information on the contents of the container 1000''').

[0127] The cooler container assembly 1000''' can optionally also include a user interface 184'''. In FIG. 33, the user interface 184''' is on the side of the container 1000'''. In another implementation, the user interface 184''' is disposed on a top surface (e.g., a corner) of the housing 102''' of the container 1000''' and/or a surface of the lid 400'''. The user interface 184''' can optionally be a button (e.g., a "return home" button). In one implementation, the user interface 184''' is a depressible button. In another implementation, the user interface 184''' is a capacitive sensor (e.g., touch sensitive sensor, touch sensitive switch). In another implementation, the user interface 184''' is a sliding switch (e.g., sliding lever). In another implementation, the user interface 184''' is a rotatable dial. In still another implementation, the user interface 184''' can be a touch screen portion (e.g., separate from or

incorporated as part of the display screen 188'''). Advantageously, actuation of the user interface 184''' can alter the information shown on the display 188'', such as the form of a shipping label shown on an E-ink display 188''. For example, actuation of the user interface 184'', can switch the text associated with the sender and receiver, allowing the cooler container assembly 1000''' to be shipped back to the sender once the receiving party is done with it. Additionally or alternatively, actuation of the user interface 184''' causes (e.g., automatically causes) a signal to be sent by circuitry in the assembly 1000'', as discussed above, to a shipping carrier (e.g., UPS, FedEx, DHL) informing the shipping carrier that a shipping label (e.g., new shipping label) has been assigned to the portable cooler 1000''' and that the cooler is ready for pick-up and shipping.

[0128] Advantageously, the cooler container 1000, 1000', 1000'', 1000''' can be reused multiple times (e.g., 500 times, 1000 times, 1500 times, 20000 times), providing a sustainable cooler container for the delivery of perishable material (e.g., medicine, food, other perishables). Additionally, the container 1000, 1000', 1000'', 1000''' is easy to use and streamlines the shipping process. For example, the user interface 184''' (e.g., button) makes it easy to return the container without having to print a new shipping label and without having to separately contact the shipping carrier for pickup, thereby improving the productivity of personnel handling the packages. The cooler containers 1000, 1000', 1000'', 1000''' can be stacked, for example in columns of 6 containers 1000, 1000', 1000'', 1000'', allowing a user to stack and unstack them without the need for a ladder.

Additional Embodiments

[0129] In embodiments of the present disclosure, a portable cooler container system may be in accordance with any of the following clauses:

Clause 1. A portable cooler container with active temperature control, comprising:

a container body having a chamber;

a frame coupled to a bottom end and a top end of the container, the frame having a plurality of openings to allow air to flow about the container, the frame having one or more air intake openings and one or more proximal vent openings and one or more distal vent openings in fluid communication via one or more vent

channels, one or more proximal electrical contacts and one or more distal electrical contacts

a lid removably coupleable to the container body to access the chamber; and

a temperature control system comprising

a cold side heat sink,

a hot side heat sink ,

a thermoelectric module interposed between and in thermal communication with the cold side heat sink and hot side heat sink,

a hot side fan operable to draw air via the air intake openings, over the hot side heat sink to heat the air, and to exhaust the heated air via the distal vent openings,

one or more cold side fans operable to flow air over the cold side heat sink to cool the air and into a channel in thermal communication with the chamber to thereby cool the chamber,

one or more batteries, and

circuitry configured to control an operation of one or more of the thermoelectric module, hot side fan and cold side fans to cool at least a portion of the chamber to a predetermined temperature or temperature range.

Clause 2. The portable cooler container of any preceding clause, further comprising a display screen disposed on one or both of the container body and the lid, the display screen configured to selectively display shipping information for the portable cooler container using electronic ink.

Clause 3. The portable cooler container of any preceding clause, further comprising a button or touch screen actuatable by a user to automatically switch sender and recipient information on the display screen to facilitate return of the portable cooler container to a sender.

Clause 4. The portable cooler container of any preceding clause, further comprising a phase change material or thermal mass in thermal communication with the chamber and the channel, the phase change material or thermal mass configured to be cooled by the cooled fluid flowing through the channel.

Clause 5. The portable cooler container of any preceding clause, further comprising one or more sensors configured to sense the one or more parameters of the chamber or temperature control system and to communicate the sensed information to the circuitry.

Clause 6. The portable cooler container of any preceding clause, wherein at least one of the one or more sensors is a temperature sensor configured to sense a temperature in the chamber and to communicate the sensed temperature to the circuitry, the circuitry configured to communicate the sensed temperature data to the cloud-based data storage system or remote electronic device.

Clause 7. The portable cooler container of any preceding clause, wherein the container body is stackable such that electrical contacts on one container body contact electrical contacts in an adjacent container body, and so that proximal vent openings in one container body align with distal vent openings in an adjacent container body to thereby allow heated air to be exhausted from the stacked containers in a chimney-like manner.

Clause 8. A portable cooler container with active temperature control, comprising:

a container body having a chamber;

a frame coupled to a bottom end and a top end of the container, the frame having a plurality of openings to allow air to flow about the container, the frame having one or more air intake openings and one or more proximal vent openings and one or more distal vent openings in fluid communication via one or more vent channels, one or more proximal electrical contacts and one or more distal electrical contacts

a lid removably coupleable to the container body to access the chamber; and

a temperature control system comprising

a cold side heat sink,

a hot side heat sink ,

a thermoelectric module interposed between and in thermal communication with the cold side heat sink and hot side heat sink,

a hot side fan operable to draw air via the air intake openings, over the hot side heat sink to heat the air, and to exhaust the heated air via the distal vent openings,

a cooling loop operable to flow a cooled fluid over the cold side heat sink to cool the fluid and into a channel in thermal communication with the chamber to thereby cool the chamber,

one or more batteries, and

circuitry configured to control an operation of one or more of the thermoelectric module, hot side fan and cold side fans to cool at least a portion of the chamber to a predetermined temperature or temperature range.

Clause 9. A portable cooler container with active temperature control, comprising:

a container body having a chamber;

a frame coupled to a bottom end and a top end of the container, the frame having a plurality of openings to allow air to flow about the container, the frame having one or more air intake openings and one or more proximal vent openings and one or more distal vent openings in fluid communication via one or more vent channels, one or more proximal electrical contacts and one or more distal electrical contacts

a lid removably coupleable to the container body to access the chamber; and

a temperature control system comprising

a cold side heat sink,

a hot side heat sink ,

a thermoelectric module interposed between and in thermal communication with the cold side heat sink and hot side heat sink,

a hot side fan operable to draw air via the air intake openings, over the hot side heat sink to heat the air, and to exhaust the heated air via the distal vent openings,

one or more cold side fans operable to flow air over the cold side heat sink to cool the air and into a channel in thermal communication with the chamber to thereby cool the chamber,

one or more batteries, and

circuitry configured to control an operation of one or more of the thermoelectric module, hot side fan and cold side fans to cool at least a portion of the chamber to a predetermined temperature or temperature range.

Clause 10. The portable cooler container of clause 9, further comprising a display screen disposed on one or both of the container body and the lid, the display screen configured to selectively display shipping information for the portable cooler container using electronic ink.

Clause 11. The portable cooler container of any of clauses 9-10, further comprising a button or touch screen actuatable by a user to automatically switch sender and recipient information on the display screen to facilitate return of the portable cooler container to a sender.

Clause 12. The portable cooler container of any of clauses 9-11, further comprising a phase change material or thermal mass in thermal communication with the chamber and the channel, the phase change material or thermal mass configured to be cooled by the cooled fluid flowing through the channel.

Clause 13. The portable cooler container of any of clauses 9-12, further comprising one or more sensors configured to sense the one or more parameters of the chamber or temperature control system and to communicate the sensed information to the circuitry.

Clause 14. The portable cooler container of any of clauses 9-13, wherein at least one of the one or more sensors is a temperature sensor configured to sense a temperature in the chamber and to communicate the sensed temperature to the circuitry, the circuitry configured to communicate the sensed temperature data to the cloud-based data storage system or remote electronic device.

Clause 15. The portable cooler container of any of clauses 9-14, wherein the container body is stackable such that electrical contacts on one container body contact electrical contacts in an adjacent container body, and so that proximal vent openings in one container body align with distal vent openings in an adjacent container body to thereby allow heated air to be exhausted from the stacked containers in a chimney-like manner.

Clause 16. A portable cooler container with active temperature control, comprising:
a container body having a chamber;

a frame coupled to a bottom end and a top end of the container, the frame having a plurality of openings to allow air to flow about the container, the frame having one or more air intake openings and one or more proximal vent openings and one or more distal vent openings in fluid communication via one or more vent channels, one or more proximal electrical contacts and one or more distal electrical contacts

a lid removably coupleable to the container body to access the chamber; and

a temperature control system comprising

a cold side heat sink,

a hot side heat sink ,

a thermoelectric module interposed between and in thermal communication with the cold side heat sink and hot side heat sink,

a hot side fan operable to draw air via the air intake openings, over the hot side heat sink to heat the air, and to exhaust the heated air via the distal vent openings,

a cooling loop operable to flow a cooled fluid over the cold side heat sink to cool the fluid and into a channel in thermal communication with the chamber to thereby cool the chamber,

one or more batteries, and

circuitry configured to control an operation of one or more of the thermoelectric module, hot side fan and cold side fans to cool at least a portion of the chamber to a predetermined temperature or temperature range.

Clause 17. The portable cooler container of any preceding clause, wherein the one or more batteries are in a module removably coupleable to the cooler container, the module being interchangeable.

Clause 18. A portable cooler container system, comprising:

a container body having a chamber;

a sleeve disposed about the chamber and housing a phase change material or thermal mass;

a conduit extending through the sleeve in a coiled path, an outer surface of the conduit in thermal communication with the phase change material or thermal mass;

a lid removably coupleable to the container body to access the chamber; and

a temperature control system comprising

- a cold side heat sink in thermal communication with the conduit,
- a hot side heat sink ,
- a thermoelectric module interposed between and in thermal communication with the cold side heat sink and hot side heat sink,
- a hot side fan operable to draw air via the air intake openings, over the hot side heat sink to heat the air, and to exhaust the heated air via the distal vent openings,
- a pump operable to flow a fluid relative to the cold side heat sink to cool the fluid and to flow the cooled fluid through the conduit in the sleeve to cool the phase change material or thermal mass so that the phase change material or thermal mass can cool at least a portion of the chamber, and
- circuitry configured to control an operation of one or more of the thermoelectric module, hot side fan and pump.

Clause 19. The portable cooler container system of clause 18, further comprising a display screen disposed on one or both of the container body and the lid, the display screen configured to selectively display shipping information for the portable cooler container using electronic ink.

Clause 20. The portable cooler container system of any of clauses 18-19, further comprising a button or touch screen actuatable by a user to automatically switch sender and recipient information on the display screen to facilitate return of the portable cooler container to a sender.

Clause 21. The portable cooler container system of any of clauses 18-20, further comprising one or more sensors configured to sense the one or more parameters of the chamber or temperature control system and to communicate the sensed information to the circuitry.

Clause 22. The portable cooler container system of any of clauses 18-21, wherein at least one of the one or more sensors is a temperature sensor configured to sense a temperature in the chamber and to communicate the sensed temperature to the circuitry, the circuitry configured to communicate the sensed temperature data to the cloud-based data storage system or remote electronic device.

Clause 23. The portable cooler container system of any of clauses 18-22, wherein the container body is stackable such that electrical contacts on one container body contact electrical contacts in an adjacent container body, and so that proximal vent openings in one container body align with distal vent openings in an adjacent container body to thereby allow heated air to be exhausted from the stacked containers in a chimney-like manner.

Clause 24. The portable cooler container system of any of clauses 18-23, wherein the temperature control system is disposed outside the container body and is selectively coupleable to the container body to charge or cool the phase change material or thermal mass.

Clause 25. A portable cooler container system, comprising:

- a container body having a chamber;

- a sleeve disposed about the chamber and housing a phase change material;

- a conduit extending through the sleeve in a coiled path, an outer surface of the conduit in thermal communication with the phase change material;

- a lid removably coupleable to the container body to access the chamber; and

- a temperature control system comprising

- a cold side heat sink in thermal communication with the conduit,

- a hot side heat sink,

- a thermoelectric module interposed between and in thermal communication with the cold side heat sink and hot side heat sink,

- a hot side fan operable to draw air via the air intake openings, over the hot side heat sink to heat the air, and to exhaust the heated air via the distal vent openings,

- a pump operable to flow a fluid relative to the cold side heat sink to cool the fluid and to flow the cooled fluid through the conduit in the sleeve to

charge the phase change material so that the phase change material can cool at least a portion of the chamber, and

circuitry configured to control an operation of one or more of the thermoelectric module, hot side fan and pump.

Clause 26. The portable cooler container system of clause 25, further comprising a display screen disposed on one or both of the container body and the lid, the display screen configured to selectively display shipping information for the portable cooler container using electronic ink.

Clause 27. The portable cooler container system of any of clauses 25-26, further comprising a button or touch screen actuatable by a user to automatically switch sender and recipient information on the display screen to facilitate return of the portable cooler container to a sender.

Clause 28. The portable cooler container system of any of clauses 25-27, further comprising one or more sensors configured to sense the one or more parameters of the chamber or temperature control system and to communicate the sensed information to the circuitry.

Clause 29. The portable cooler container system of any of clauses 25-28, wherein at least one of the one or more sensors is a temperature sensor configured to sense a temperature in the chamber and to communicate the sensed temperature to the circuitry, the circuitry configured to communicate the sensed temperature data to the cloud-based data storage system or remote electronic device.

Clause 30. The portable cooler container system of any of clauses 25-29, wherein the container body is stackable such that electrical contacts on one container body contact electrical contacts in an adjacent container body, and so that proximal vent openings in one container body align with distal vent openings in an adjacent container body to thereby allow heated air to be exhausted from the stacked containers in a chimney-like manner.

Clause 31. The portable cooler container system of any of clauses 25-30, wherein the temperature control system is disposed outside the container body and is selectively coupleable to the container body to charge the phase change material.

Clause 32. A portable cooler container system, comprising:

a chamber configured to receive one or more perishable components;

a first wall circumferentially disposed about the chamber and under a base of the chamber;

a second wall circumferentially disposed about the first wall and under a base portion of the first wall, the second wall spaced apart from the first wall so as to define a gap therebetween, the gap being under vacuum to thereby thermally insulate the first wall from the second wall to thereby thermally insulate the chamber;

an outer housing disposed about the second wall;

a lid removably coupleable over the chamber to substantially seal the chamber; and

an electronic display screen configured to selectively display an electronic shipping label for the portable cooler container.

Clause 33. The portable cooler container system of clause 32, further comprising circuitry configured to communicate with the electronic display screen

Clause 34. The portable cooler container system of any of clauses 32-33, further comprising a phase change material or thermal mass in thermal communication with the chamber to cool the one or more perishable components.

Clause 35. The portable cooler container system of any of clauses 32-34, further comprising a button or touch screen actuatable by a user to one or both of a) automatically switch sender and recipient information on the display screen to facilitate return of the portable cooler container to a sender and b) automatically contact a shipping carrier to alert the shipping carrier that a new electronic shipping label has been issued and that the container is ready for pickup.

Clause 36. The portable cooler container system of any of clauses 32-35, further comprising one or more sensors configured to sense the one or more parameters of the chamber and to communicate the sensed parameters to the circuitry.

Clause 37. The portable cooler container system of any of clauses 32-36, wherein at least one of the one or more sensors is a temperature sensor configured to sense a temperature in the chamber.

Clause 38. The portable cooler container system of any of clauses 32-37, wherein the circuitry is configured to communicate with a cloud-based server system or remote electronic device.

Clause 39. The portable cooler container system of any of clauses 32-38, wherein the electronic display screen is an electronic ink display screen.

Clause 40. The portable cooler container system of any of clauses 32-39, wherein the outer housing comprises a thermally insulative material.

Clause 41. The portable cooler container system of any of clauses 32-40, wherein the lid is a vacuum insulated lid.

Clause 42. A portable cooler container system, comprising:

- a container body having a chamber configured to receive one or more perishable goods;

- a sleeve disposed about the chamber and housing a phase change material or thermal mass;

- a conduit extending through the sleeve, an outer surface of the conduit in thermal communication with the phase change material or thermal mass;

- a lid hingedly coupleable or removably coupleable to the container body to access the chamber; and

- a temperature control system comprising

- a cold side heat sink in thermal communication with at least a portion of the conduit,

- a hot side heat sink,

- a thermoelectric module interposed between and in thermal communication with the cold side heat sink and hot side heat sink,

- a pump operable to flow a fluid relative to the cold side heat sink to cool the fluid and to flow the cooled fluid through the conduit in the sleeve to charge the phase change material or thermal mass so that the phase change material or thermal mass is configured to cool at least a portion of the chamber, and

circuitry configured to control an operation of one or both of the thermoelectric module and pump.

Clause 43. The portable cooler container system of clause 42, wherein the conduit extends through the sleeve along a coiled path.

Clause 44. The portable cooler container system of any of clauses 42-43, further comprising a display screen disposed on one or both of the container body and the lid, the display screen configured to selectively display shipping information for the portable cooler container.

Clause 45. The portable cooler container system of any of clauses 42-44, wherein the display screen is an electrophoretic ink display.

Clause 46. The portable cooler container system of any of clauses 42-45, further comprising a button or touch screen manually actuatable by a user to automatically switch sender and recipient information on the display screen to facilitate return of the portable cooler container to a sender.

Clause 47. The portable cooler container system of any of clauses 42-46, further comprising one or more sensors configured to sense one or more parameters of the chamber or temperature control system and to communicate the sensed information to the circuitry.

Clause 48. The portable cooler container system of any of clauses 42-47, wherein at least one of the one or more sensors is a temperature sensor configured to sense a temperature in the chamber and to communicate the sensed temperature to the circuitry, the circuitry configured to communicate the sensed temperature data to a cloud-based data storage system or remote electronic device.

Clause 49. The portable cooler container system of any of clauses 42-48, wherein the container body is stackable such that electrical contacts on one container body contact electrical contacts in an adjacent container body.

Clause 50. The portable cooler container system of any of clauses 42-49, wherein at least a portion of the temperature control system is disposed outside the container body and is selectively coupleable to the container body to cool the phase change material or thermal mass.

Clause 51. The portable cooler container system of any of clauses 42-50, further comprising one or more fins extending from an outer surface of the conduit and in thermal communication with the phase change material or thermal mass.

Clause 52. The portable cooler container system of any of clauses 42-51, wherein the container body is a vacuum insulated container body.

Clause 53. A portable cooler container, comprising:

- a double-walled vacuum insulated container body having a chamber configured to receive and hold one or more perishable goods;

- a lid hingedly coupleable or removably coupleable to the container body to access the chamber; and

- an electronic system of the container body, comprising

- one or more batteries, and

- circuitry configured to wirelessly communicate via a cell radio with a

- cloud-based data storage system or a remote electronic device; and

- an electronic display screen on one of the lid and the container body configured to selectively display an electronic shipping label for the portable cooler container.

Clause 54. The portable cooler container system of clause 53, further comprising one or more volumes of a phase change material or thermal mass to cool the one or more perishable goods.

Clause 55. The portable cooler container system of any of clauses 53-54, further comprising a button or touch screen manually actuatable by a user to one or both of a) automatically switch sender and recipient information on the display screen to facilitate return of the portable cooler container to a sender and b) automatically contact a shipping carrier to alert the shipping carrier that a new electronic shipping label has been issued and that the container is ready for pickup.

Clause 56. The portable cooler container system of any of clauses 53-55, further comprising one or more sensors configured to sense the one or more parameters of the chamber and to communicate the sensed parameters to the circuitry.

Clause 57. The portable cooler container system of any of clauses 53-56, wherein at least one of the one or more sensors is a temperature sensor configured to sense a temperature in the chamber.

Clause 58. The portable cooler container system of any of clauses 53-57, wherein the electronic display screen is an electrophoretic ink display screen.

Clause 59. The portable cooler container system of any of clauses 53-58, wherein the lid is a vacuum insulated lid.

[0130] While certain embodiments of the inventions have been described, these embodiments have been presented by way of example only, and are not intended to limit the scope of the disclosure. Indeed, the novel methods and systems described herein may be embodied in a variety of other forms. The features disclosed herein are applicable to containers that transport all manner of perishable goods (e.g., medicine, food, beverages, living tissue or organisms) and the invention is understood to extend to such other containers. Furthermore, various omissions, substitutions and changes in the systems and methods described herein may be made without departing from the spirit of the disclosure. The accompanying claims and their equivalents are intended to cover such forms or modifications as would fall within the scope and spirit of the disclosure. Accordingly, the scope of the present inventions is defined only by reference to the appended claims.

[0131] Features, materials, characteristics, or groups described in conjunction with a particular aspect, embodiment, or example are to be understood to be applicable to any other aspect, embodiment or example described in this section or elsewhere in this specification unless incompatible therewith. All of the features disclosed in this specification (including any accompanying claims, abstract and drawings), and/or all of the steps of any method or process so disclosed, may be combined in any combination, except combinations where at least some of such features and/or steps are mutually exclusive. The protection is not restricted to the details of any foregoing embodiments. The protection extends to any novel one, or any novel combination, of the features disclosed in this specification (including any accompanying claims, abstract and drawings), or to any novel one, or any novel combination, of the steps of any method or process so disclosed.

[0132] Furthermore, certain features that are described in this disclosure in the context of separate implementations can also be implemented in combination in a single implementation. Conversely, various features that are described in the context of a single implementation can also be implemented in multiple implementations separately or in any suitable subcombination. Moreover, although features may be described above as acting in certain combinations, one or more features from a claimed combination can, in some cases, be excised from the combination, and the combination may be claimed as a subcombination or variation of a subcombination.

[0133] Moreover, while operations may be depicted in the drawings or described in the specification in a particular order, such operations need not be performed in the particular order shown or in sequential order, or that all operations be performed, to achieve desirable results. Other operations that are not depicted or described can be incorporated in the example methods and processes. For example, one or more additional operations can be performed before, after, simultaneously, or between any of the described operations. Further, the operations may be rearranged or reordered in other implementations. Those skilled in the art will appreciate that in some embodiments, the actual steps taken in the processes illustrated and/or disclosed may differ from those shown in the figures. Depending on the embodiment, certain of the steps described above may be removed, others may be added. Furthermore, the features and attributes of the specific embodiments disclosed above may be combined in different ways to form additional embodiments, all of which fall within the scope of the present disclosure. Also, the separation of various system components in the implementations described above should not be understood as requiring such separation in all implementations, and it should be understood that the described components and systems can generally be integrated together in a single product or packaged into multiple products.

[0134] For purposes of this disclosure, certain aspects, advantages, and novel features are described herein. Not necessarily all such advantages may be achieved in accordance with any particular embodiment. Thus, for example, those skilled in the art will recognize that the disclosure may be embodied or carried out in a manner that achieves one advantage or a group of advantages as taught herein without necessarily achieving other advantages as may be taught or suggested herein.

[0135] Conditional language, such as “can,” “could,” “might,” or “may,” unless specifically stated otherwise, or otherwise understood within the context as used, is generally intended to convey that certain embodiments include, while other embodiments do not include, certain features, elements, and/or steps. Thus, such conditional language is not generally intended to imply that features, elements, and/or steps are in any way required for one or more embodiments or that one or more embodiments necessarily include logic for deciding, with or without user input or prompting, whether these features, elements, and/or steps are included or are to be performed in any particular embodiment.

[0136] Conjunctive language such as the phrase “at least one of X, Y, and Z,” unless specifically stated otherwise, is otherwise understood with the context as used in general to convey that an item, term, etc. may be either X, Y, or Z. Thus, such conjunctive language is not generally intended to imply that certain embodiments require the presence of at least one of X, at least one of Y, and at least one of Z.

[0137] Language of degree used herein, such as the terms “approximately,” “about,” “generally,” and “substantially” as used herein represent a value, amount, or characteristic close to the stated value, amount, or characteristic that still performs a desired function or achieves a desired result. For example, the terms “approximately”, “about”, “generally,” and “substantially” may refer to an amount that is within less than 10% of, within less than 5% of, within less than 1% of, within less than 0.1% of, and within less than 0.01% of the stated amount. As another example, in certain embodiments, the terms “generally parallel” and “substantially parallel” refer to a value, amount, or characteristic that departs from exactly parallel by less than or equal to 15 degrees, 10 degrees, 5 degrees, 3 degrees, 1 degree, or 0.1 degree.

[0138] The scope of the present disclosure is not intended to be limited by the specific disclosures of preferred embodiments in this section or elsewhere in this specification, and may be defined by claims as presented in this section or elsewhere in this specification or as presented in the future. The language of the claims is to be interpreted broadly based on the language employed in the claims and not limited to the examples described in the present specification or during the prosecution of the application, which examples are to be construed as non-exclusive.

WHAT IS CLAIMED IS:

1. A portable cooler container system, comprising:
 - a container body having a chamber configured to receive one or more perishable goods;
 - a sleeve disposed about the chamber and housing a phase change material or thermal mass;
 - a conduit extending through the sleeve, an outer surface of the conduit in thermal communication with the phase change material or thermal mass;
 - a lid hingedly coupleable or removably coupleable to the container body to access the chamber; and
 - a temperature control system comprising
 - a cold side heat sink in thermal communication with at least a portion of the conduit,
 - a hot side heat sink,
 - a thermoelectric module interposed between and in thermal communication with the cold side heat sink and hot side heat sink,
 - a pump operable to flow a fluid relative to the cold side heat sink to cool the fluid and to flow the cooled fluid through the conduit in the sleeve to cool the phase change material or thermal mass so that the phase change material or thermal mass is configured to cool at least a portion of the chamber, and
 - circuitry configured to control an operation of one or both of the thermoelectric module and the pump.
2. The portable cooler container system of claim 1, wherein the conduit extends through the sleeve along a coiled path.
3. The portable cooler container system of claim 1, further comprising a display screen disposed on one or both of the container body and the lid, the display screen configured to selectively display shipping information for the portable cooler container.
4. The portable cooler container system of claim 3, wherein the display screen is an electrophoretic ink display.

5. The portable cooler container system of claim 3, further comprising a button or touch screen manually actuatable by a user to automatically switch sender and recipient information on the display screen to facilitate return of the portable cooler container to a sender.

6. The portable cooler container system of claim 1, further comprising one or more sensors configured to sense one or more parameters of the chamber or temperature control system and to communicate the sensed information to the circuitry.

7. The portable cooler container system of claim 6, wherein at least one of the one or more sensors is a temperature sensor configured to sense a temperature in the chamber and to communicate the sensed temperature to the circuitry, the circuitry configured to communicate the sensed temperature data to a cloud-based data storage system or remote electronic device.

8. The portable cooler container system of claim 1, wherein the container body is stackable such that electrical contacts on one container body contact electrical contacts in an adjacent container body.

9. The portable cooler container system of claim 1, wherein at least a portion of the temperature control system is disposed outside the container body and is selectively coupleable to the container body to cool the phase change material or thermal mass when coupled to the container body.

10. The portable cooler container system of claim 1, further comprising one or more fins extending from an outer surface of the conduit and in thermal communication with the phase change material or thermal mass.

11. The portable cooler container system of claim 1, wherein the container body is a vacuum insulated container body.

12. A portable cooler container system, comprising:

a container body having a chamber configured to receive one or more temperature sensitive products;

a sleeve disposed about the chamber and housing a phase change material or thermal mass;

a conduit extending through the sleeve, an outer surface of the conduit in thermal communication with the phase change material or thermal mass;

a lid hingedly coupleable or removably coupleable to the container body to access the chamber;

a temperature control system comprising

a cold side heat sink in thermal communication with at least a portion of the conduit,

a hot side heat sink,

a thermoelectric module interposed between and in thermal communication with the cold side heat sink and hot side heat sink,

a pump operable to flow a fluid relative to the cold side heat sink to cool the fluid and to flow the cooled fluid through the conduit in the sleeve to cool the phase change material or thermal mass so that the phase change material or thermal mass is configured to cool at least a portion of the chamber, and

circuitry configured to control an operation of one or both of the thermoelectric module and the pump; and

a display screen configured to selectively display shipping information for the portable cooler container.

13. The portable cooler container system of claim 12, wherein the conduit extends through the sleeve along a coiled path.

14. The portable cooler container system of claim 12, further comprising a button or touch screen manually actuatable by a user to automatically switch sender and recipient information on the display screen to facilitate return of the portable cooler container to a sender.

15. The portable cooler container system of claim 12, further comprising one or more sensors configured to sense one or more parameters of the chamber or temperature control system and to communicate the sensed information to the circuitry.

16. The portable cooler container system of claim 15, wherein at least one of the one or more sensors is a temperature sensor configured to sense a temperature in the chamber

and to communicate the sensed temperature to the circuitry, the circuitry configured to communicate the sensed temperature data to a cloud-based data storage system or remote electronic device.

17. The portable cooler container system of claim 12, wherein the container body is stackable such that electrical contacts on one container body contact electrical contacts in an adjacent container body.

18. The portable cooler container system of claim 12, wherein at least a portion of the temperature control system is disposed outside the container body and is selectively coupleable to the container body to cool the phase change material or thermal mass when coupled to the container body.

19. A portable cooler container system, comprising:

- a double-walled vacuum insulated container body having a chamber configured to receive and hold one or more perishable goods;

- a lid hingedly coupleable or removably coupleable to the container body to access the chamber; and

- an electronic system of the container body, comprising

- one or more batteries, and

- circuitry configured to wirelessly communicate via a cell radio with a

- cloud-based data storage system or a remote electronic device; and

- an electronic display screen on one of the lid and the container body configured to selectively display an electronic shipping label for the portable cooler container.

20. The portable cooler container system of claim 19, further comprising one or more removable volumes of a phase change material or thermal mass to cool the one or more perishable goods.

21. The portable cooler container system of claim 19, further comprising a button or touch screen manually actuatable by a user to one or both of a) automatically switch sender and recipient information on the display screen to facilitate return of the portable cooler container to a sender and b) automatically contact a shipping carrier to alert the shipping carrier that a new electronic shipping label has been issued and that the container is ready for pickup.

22. The portable cooler container system of claim 19, further comprising one or more sensors configured to sense the one or more parameters of the chamber and to communicate the sensed parameters to the circuitry.

23. The portable cooler container system of claim 22, wherein at least one of the one or more sensors is a temperature sensor configured to sense a temperature in the chamber.

24. The portable cooler container system of claim 19, wherein the electronic display screen is an electrophoretic ink display screen.

25. The portable cooler container system of claim 19, wherein the lid is a vacuum insulated lid.

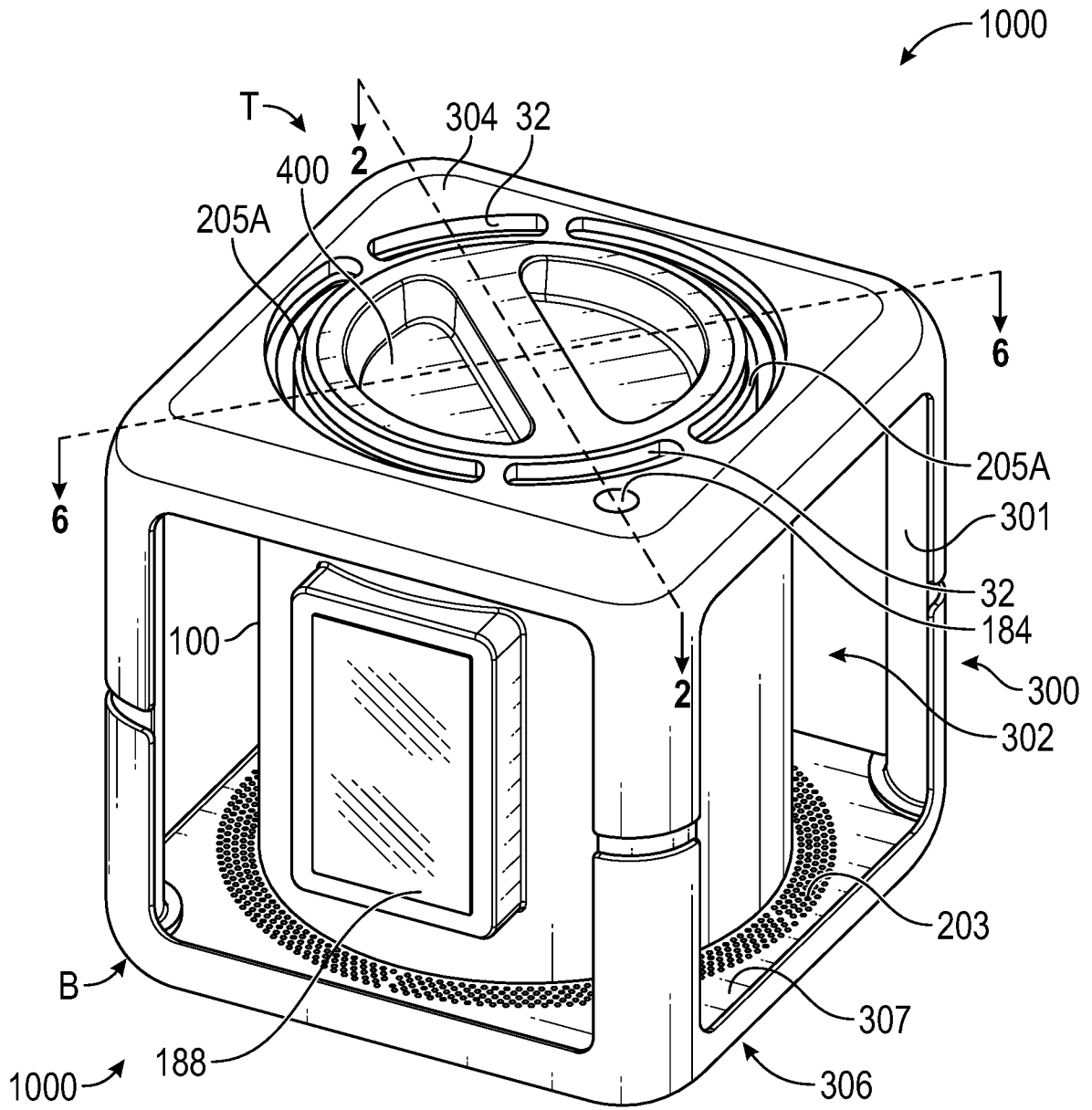

FIG. 1

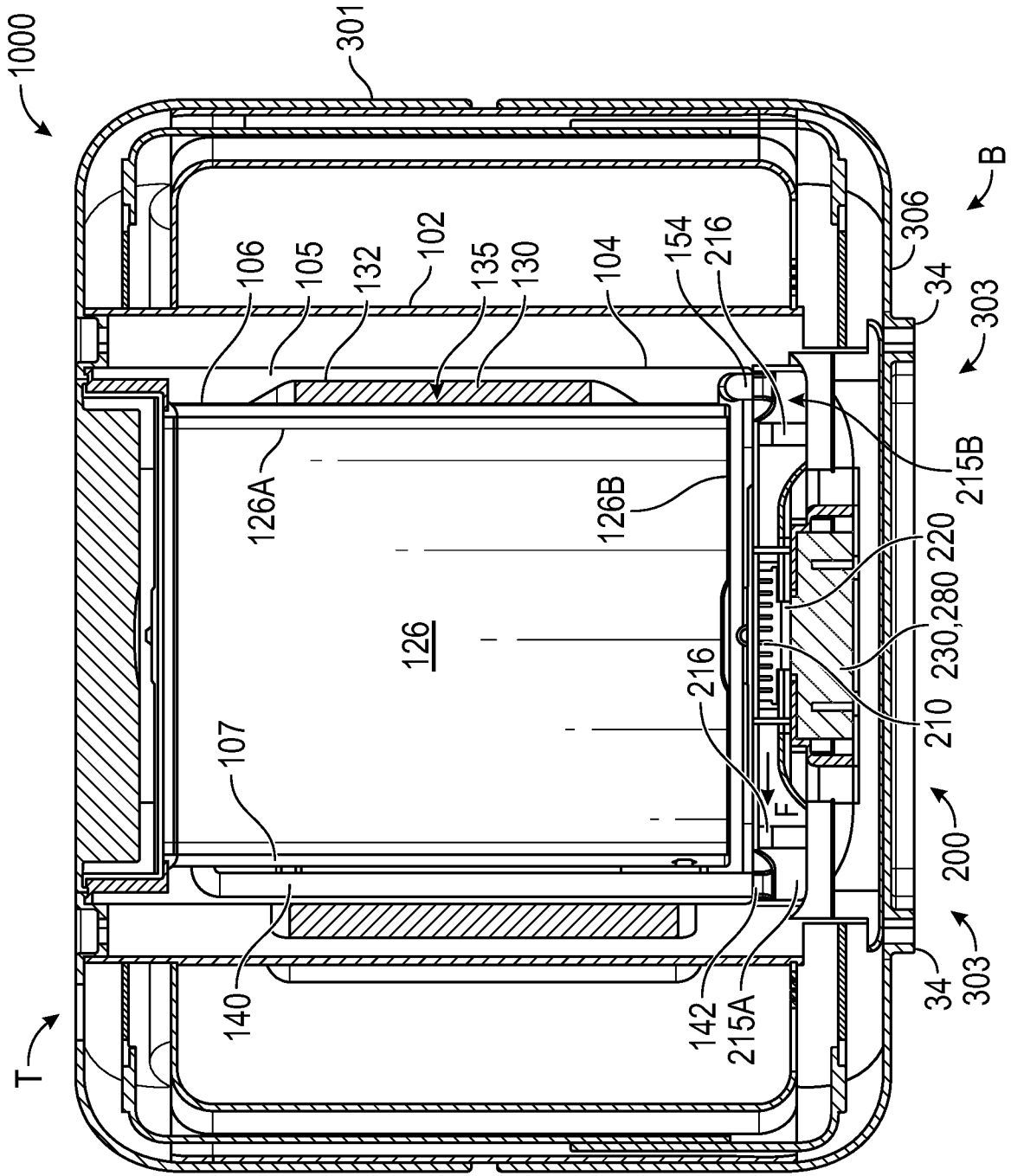

FIG. 2

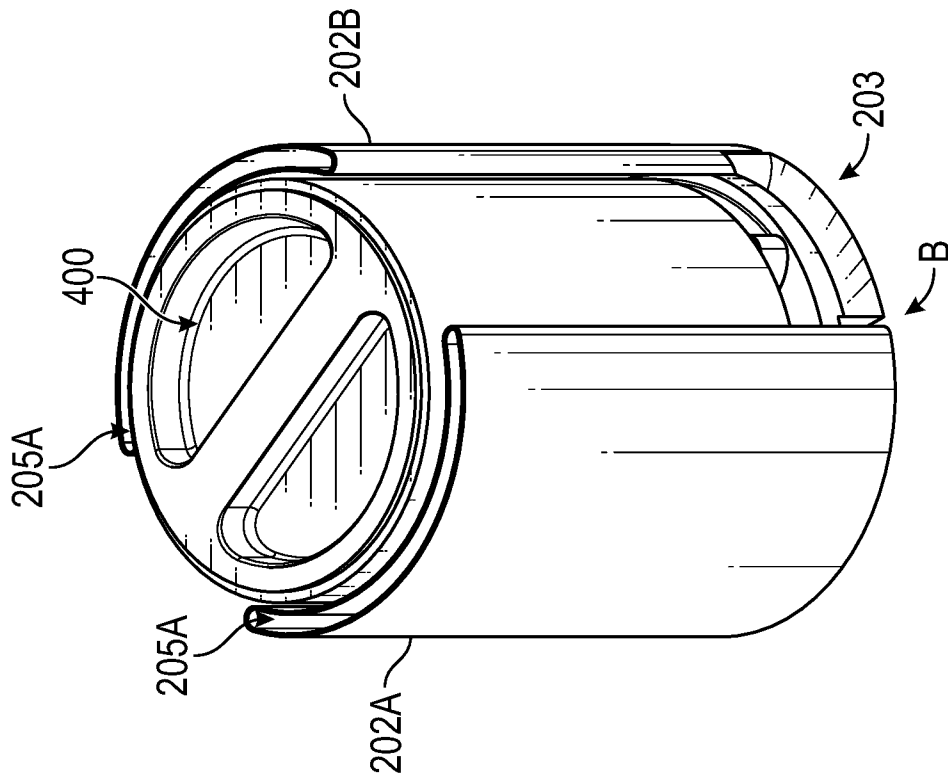

FIG. 4

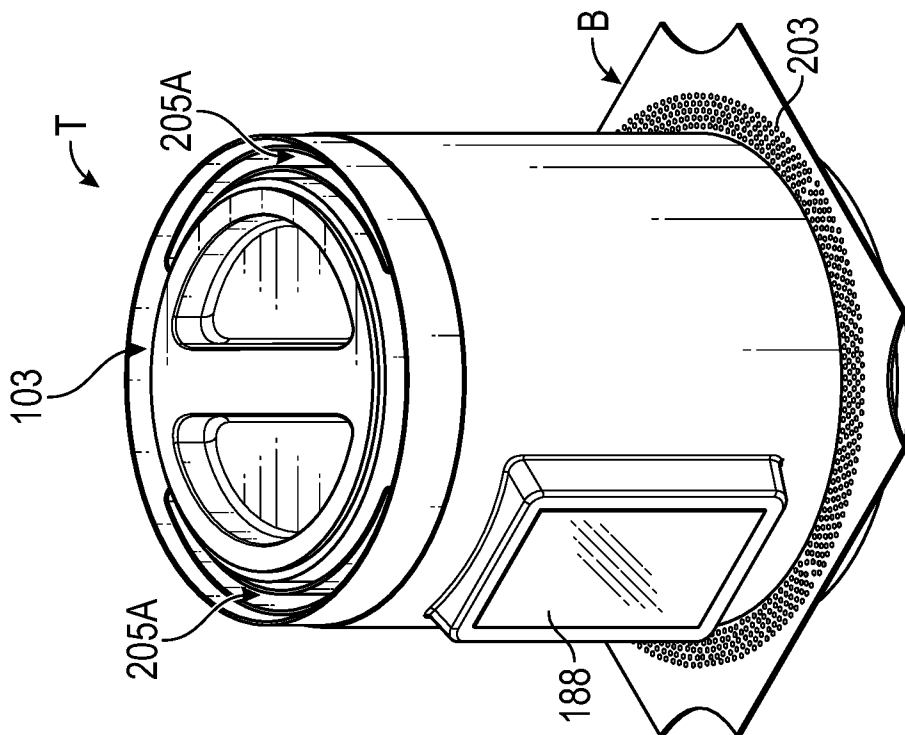

FIG. 3

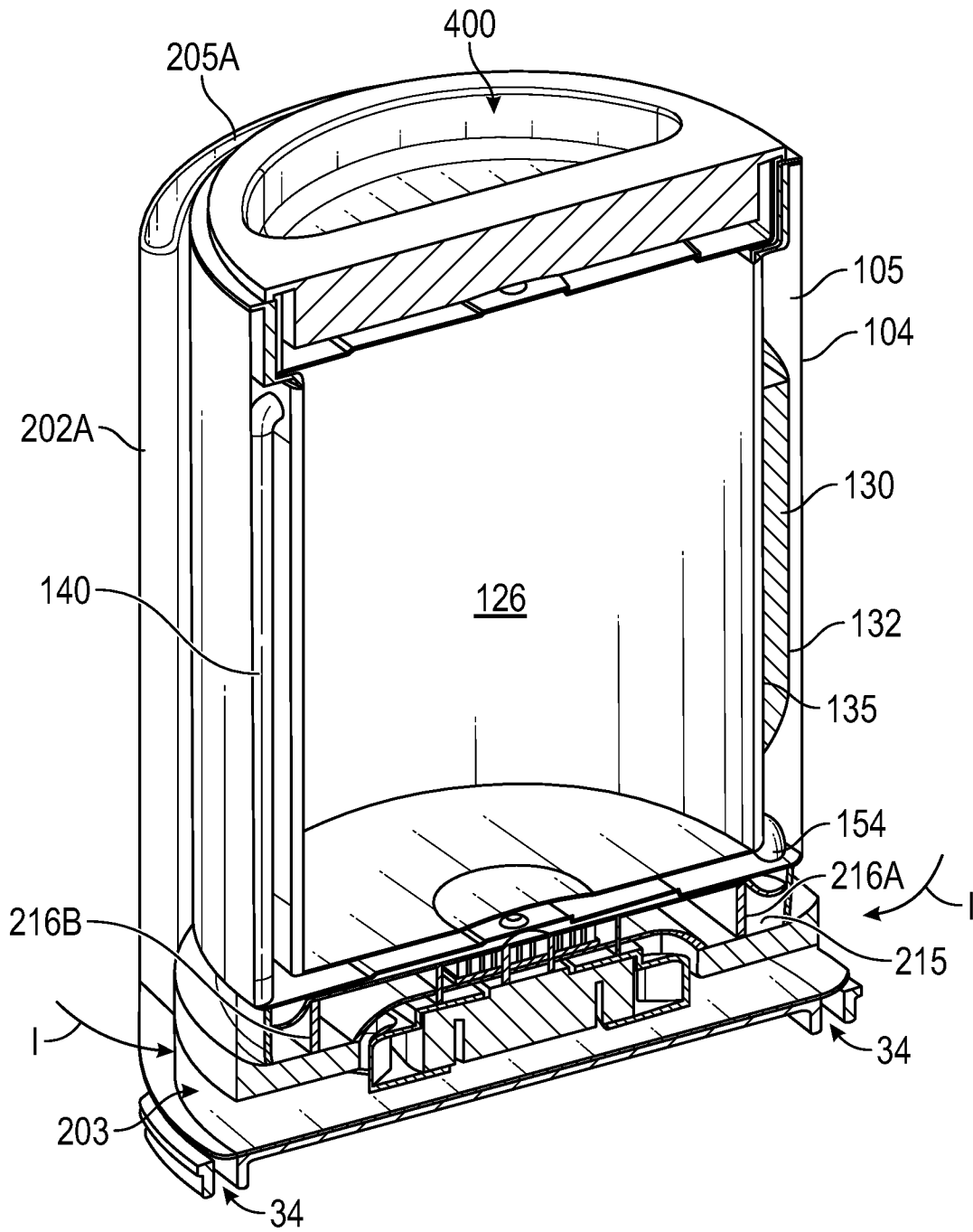

FIG. 5

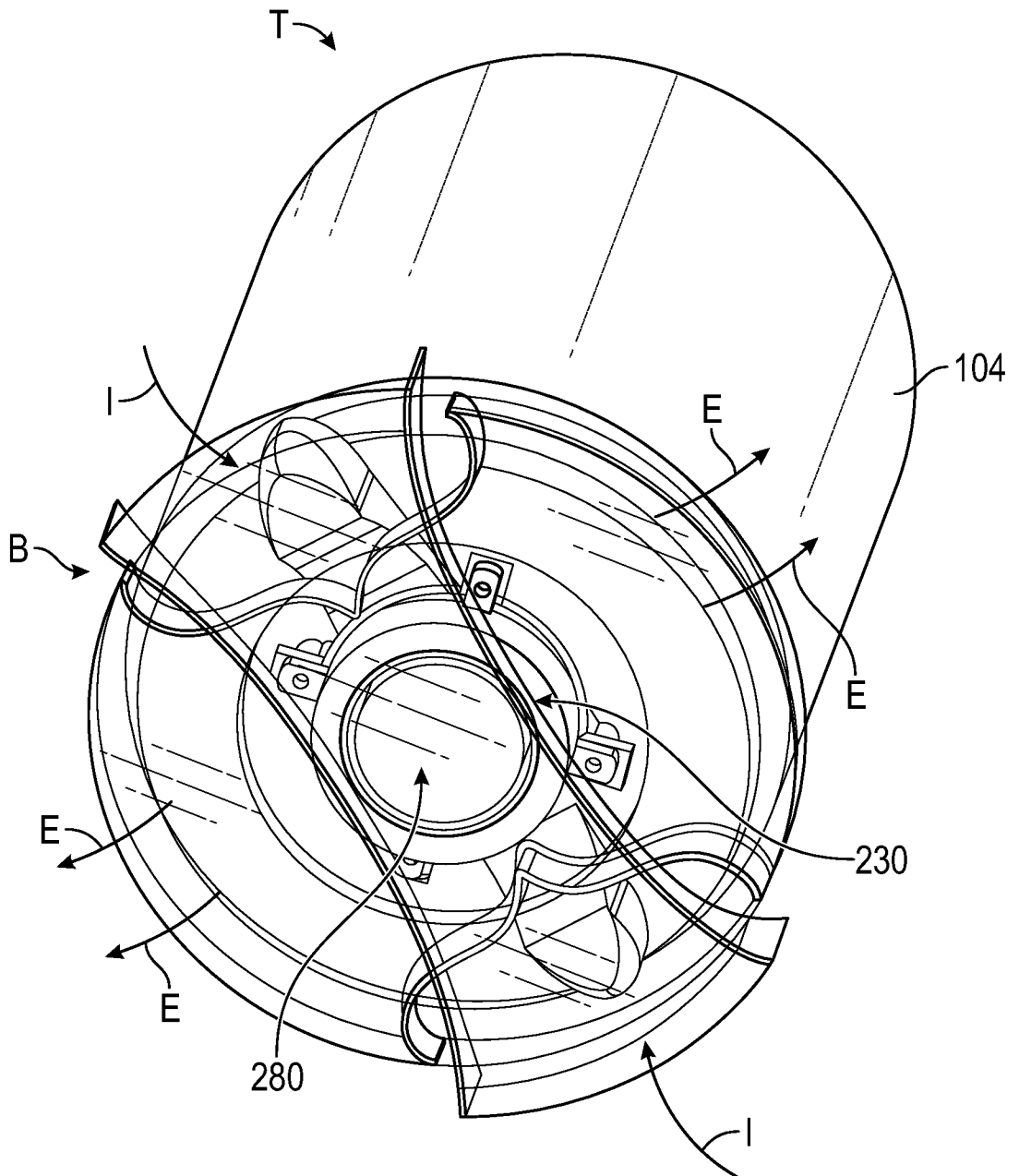

FIG. 7

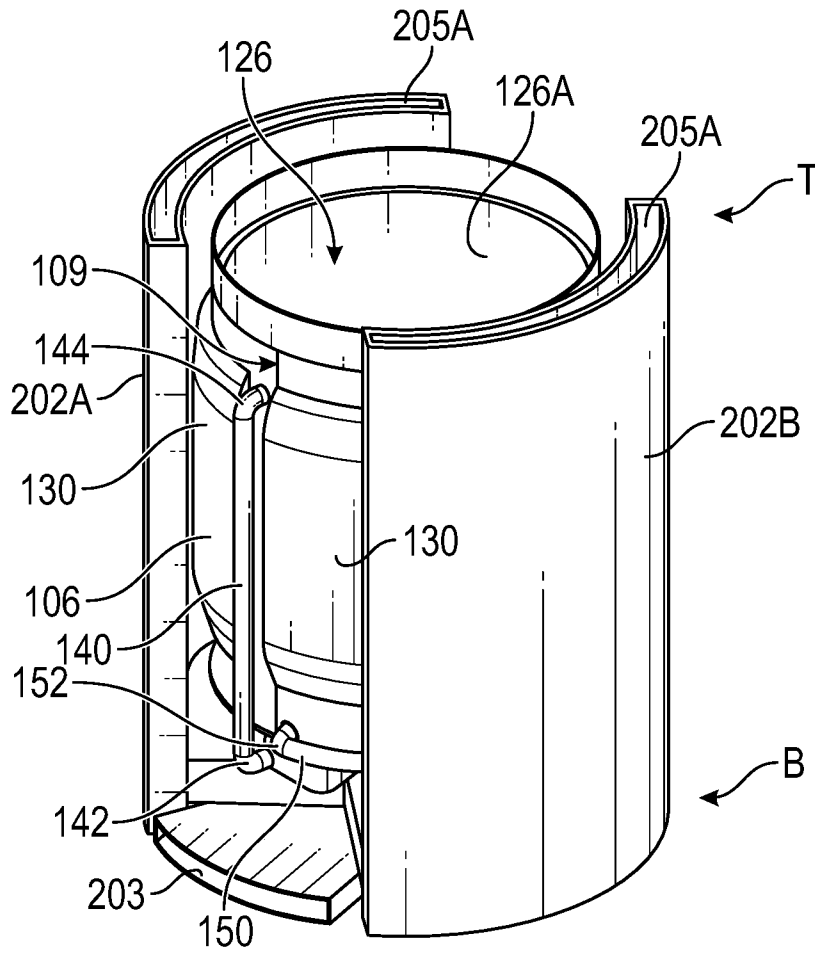

FIG. 8

8/25

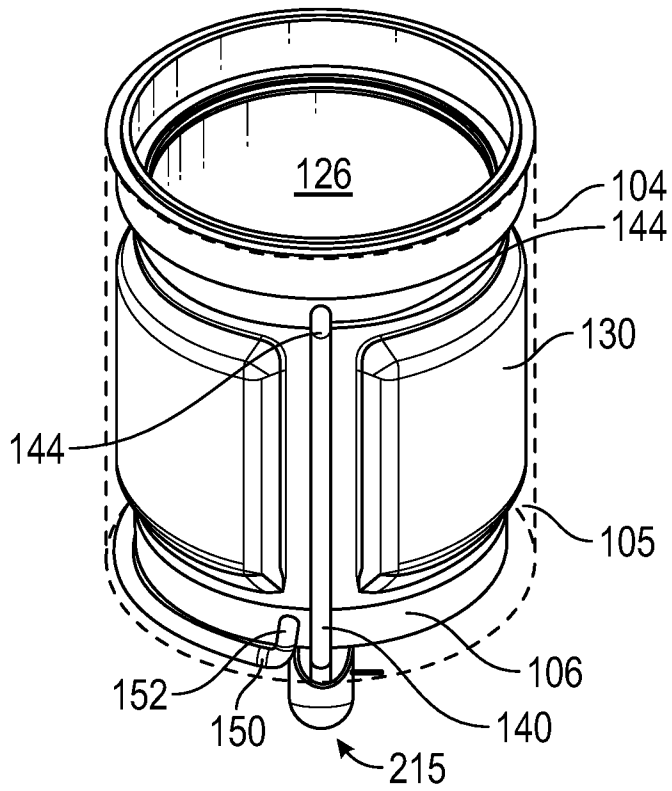

FIG. 9

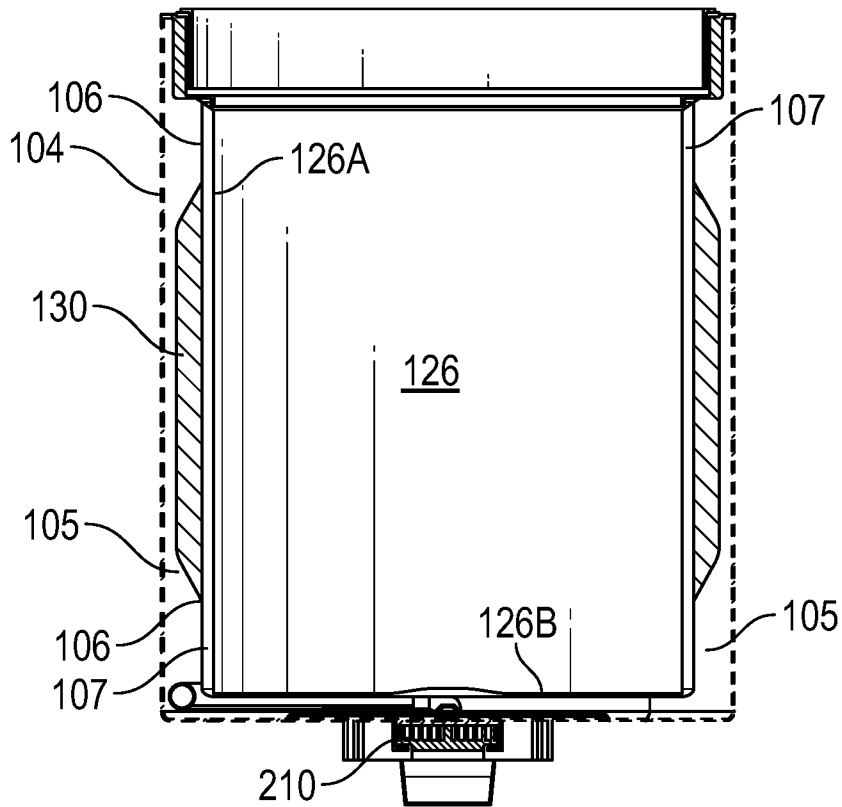

FIG. 10

9/25

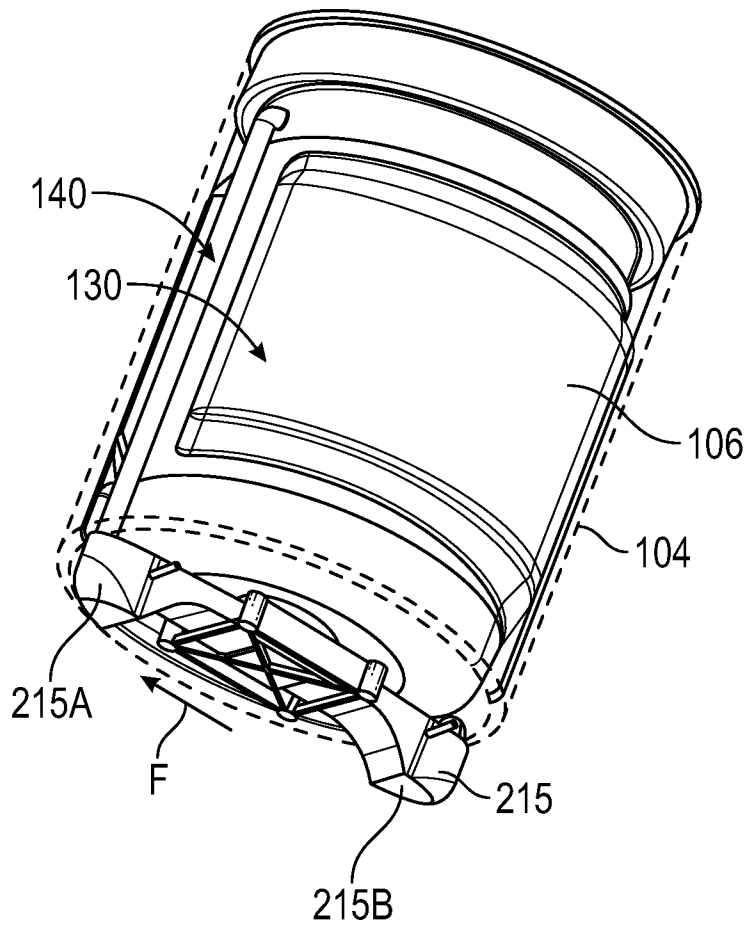

FIG. 11

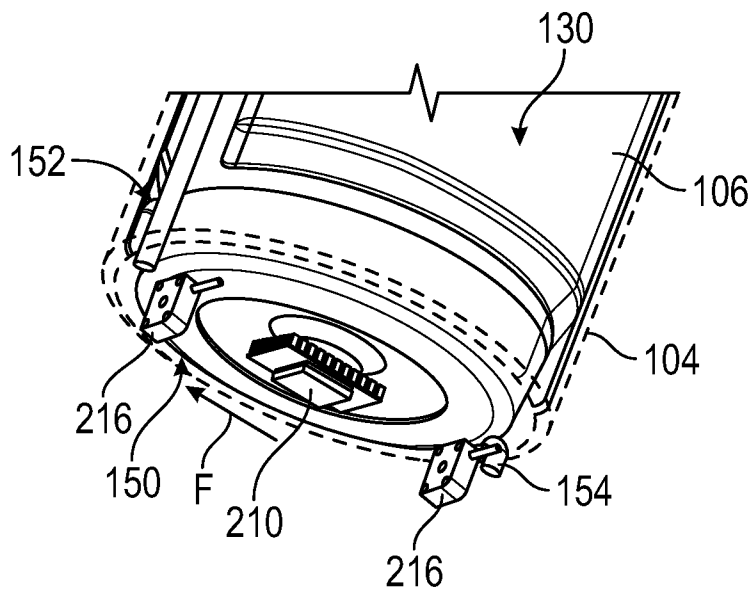

FIG. 12

10/25

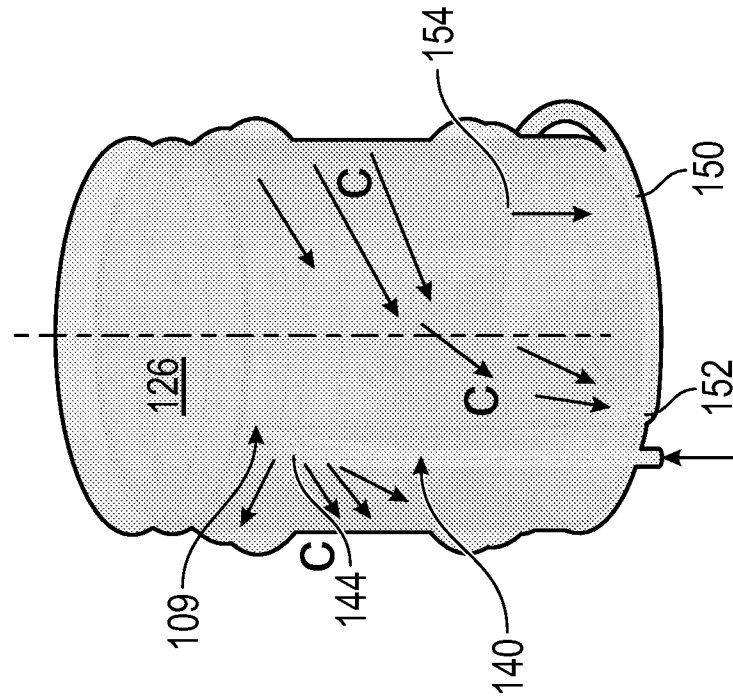

FIG. 14

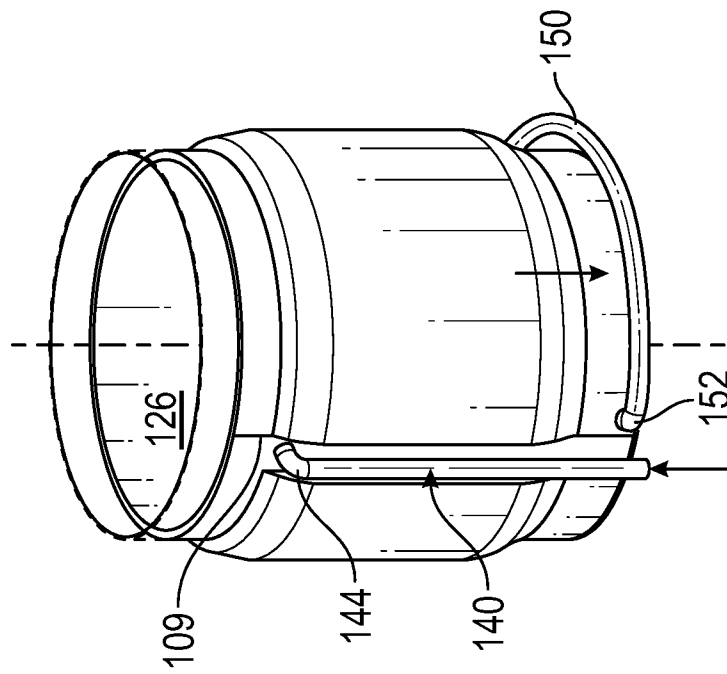

FIG. 13

11/25

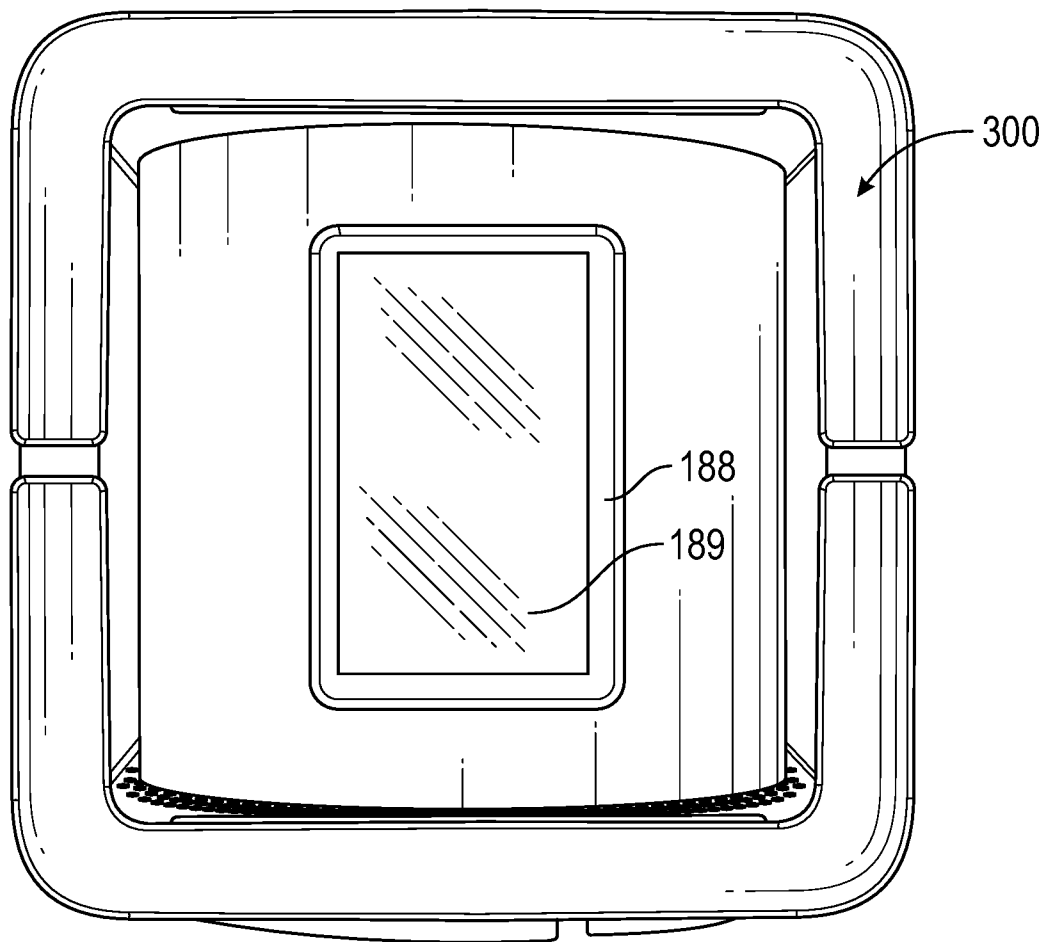

FIG. 15

12/25

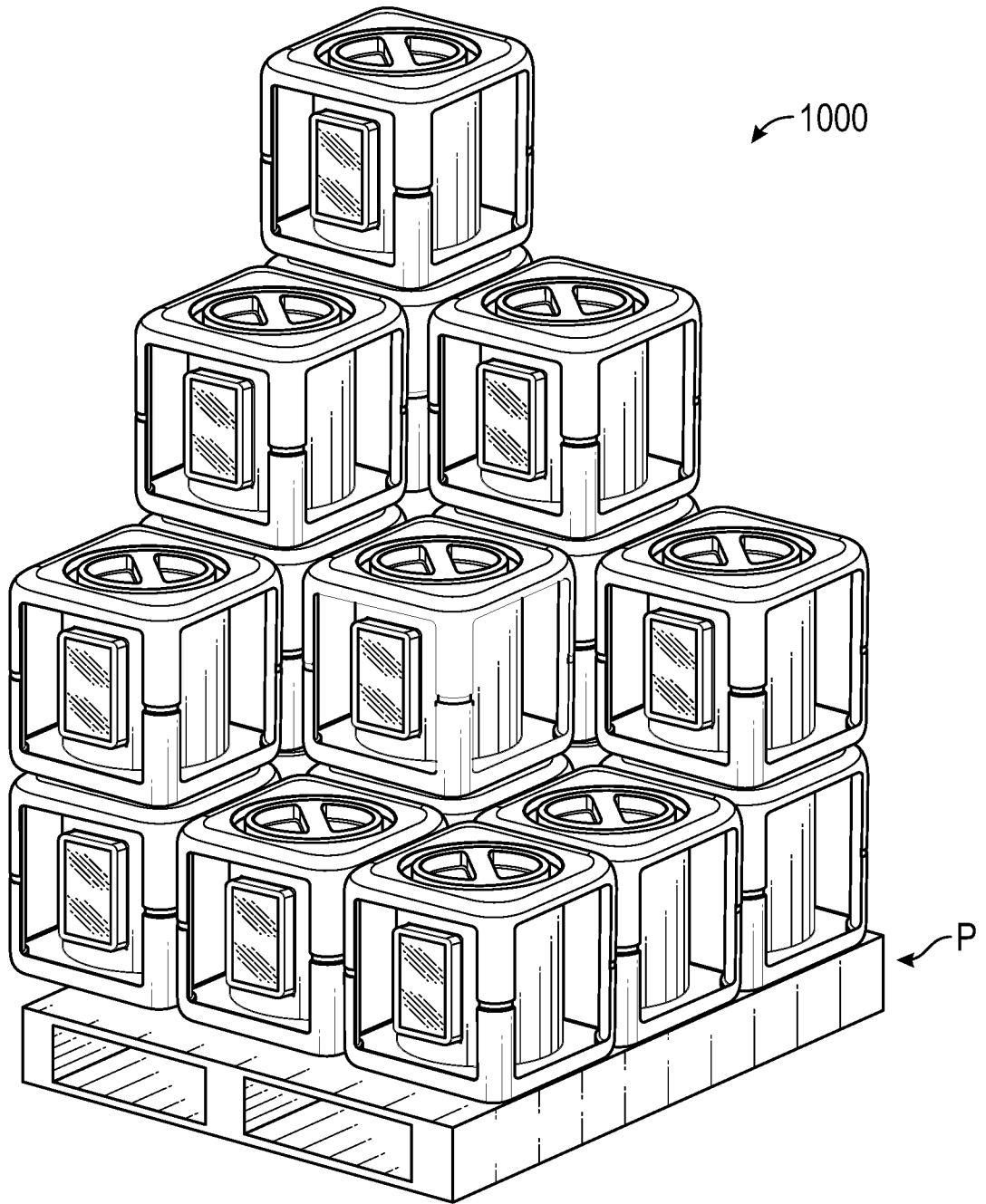

FIG. 16

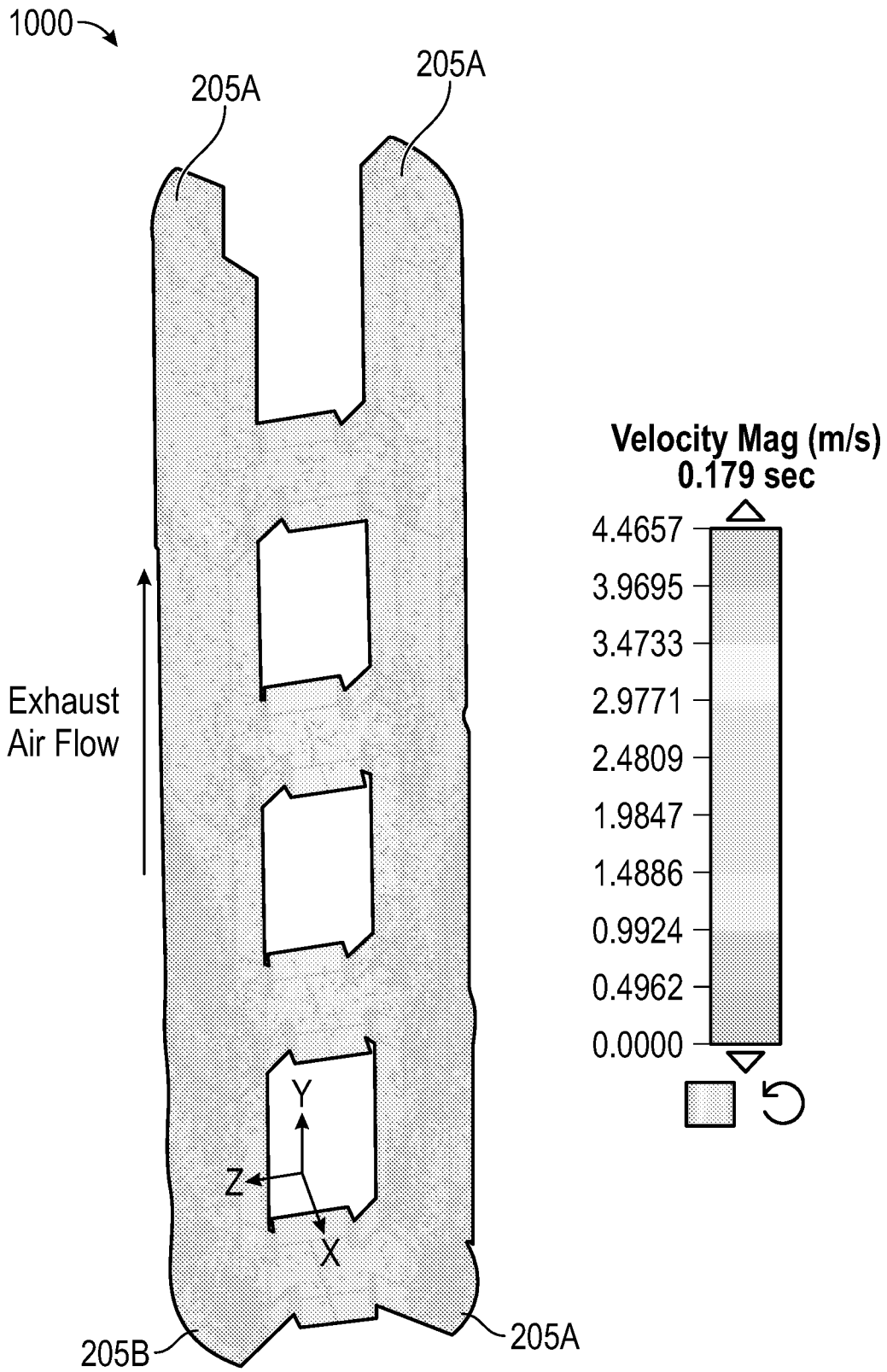

FIG. 17

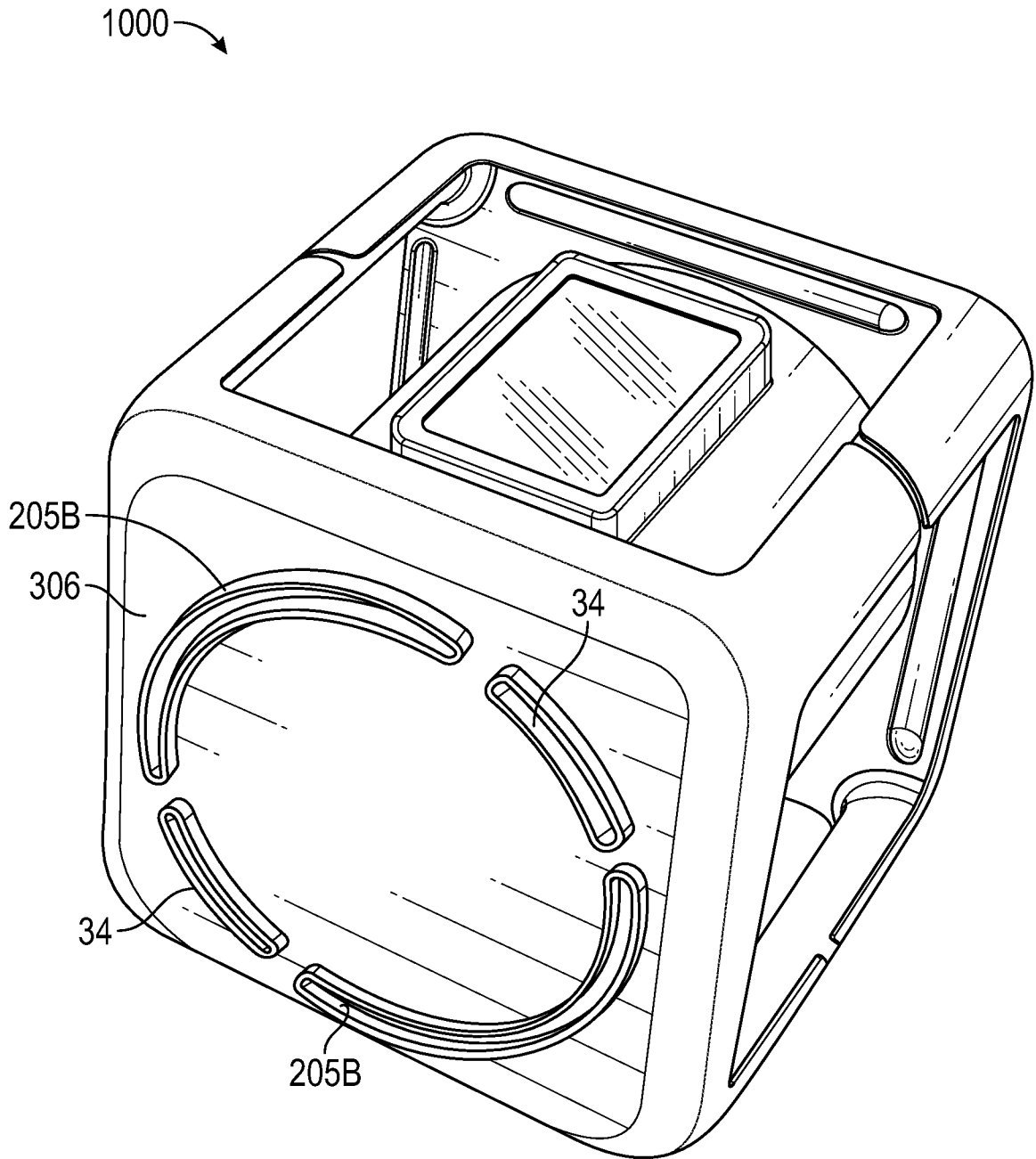

FIG. 18

16/25

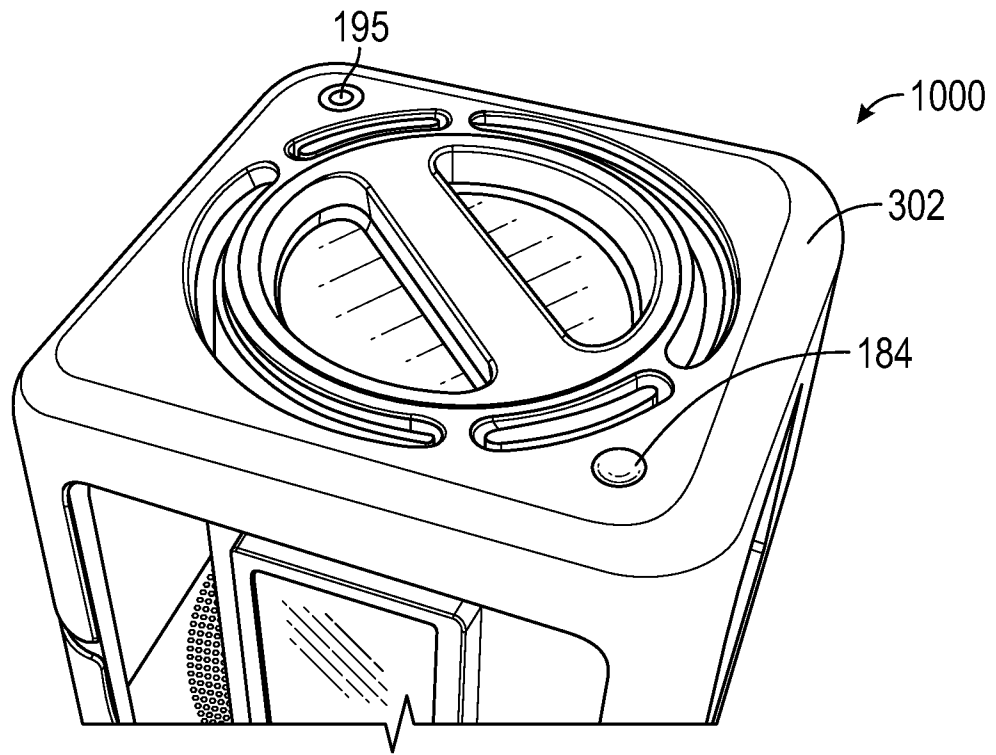

FIG. 20

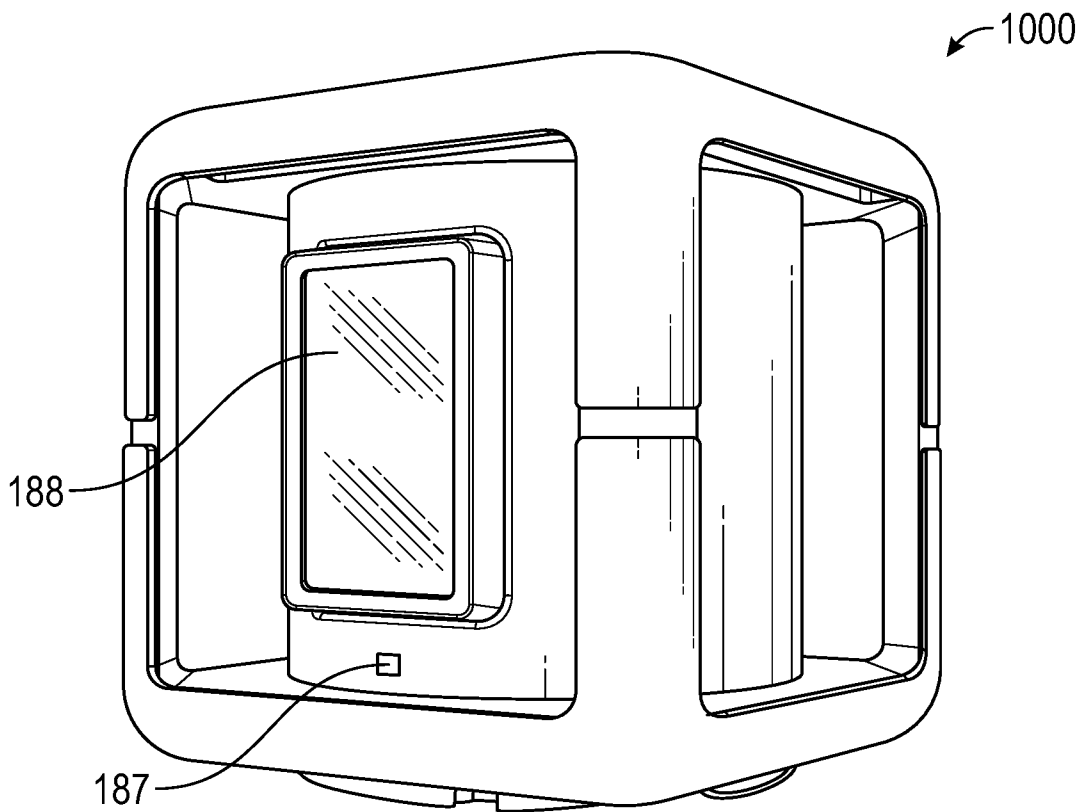

FIG. 21

17/25

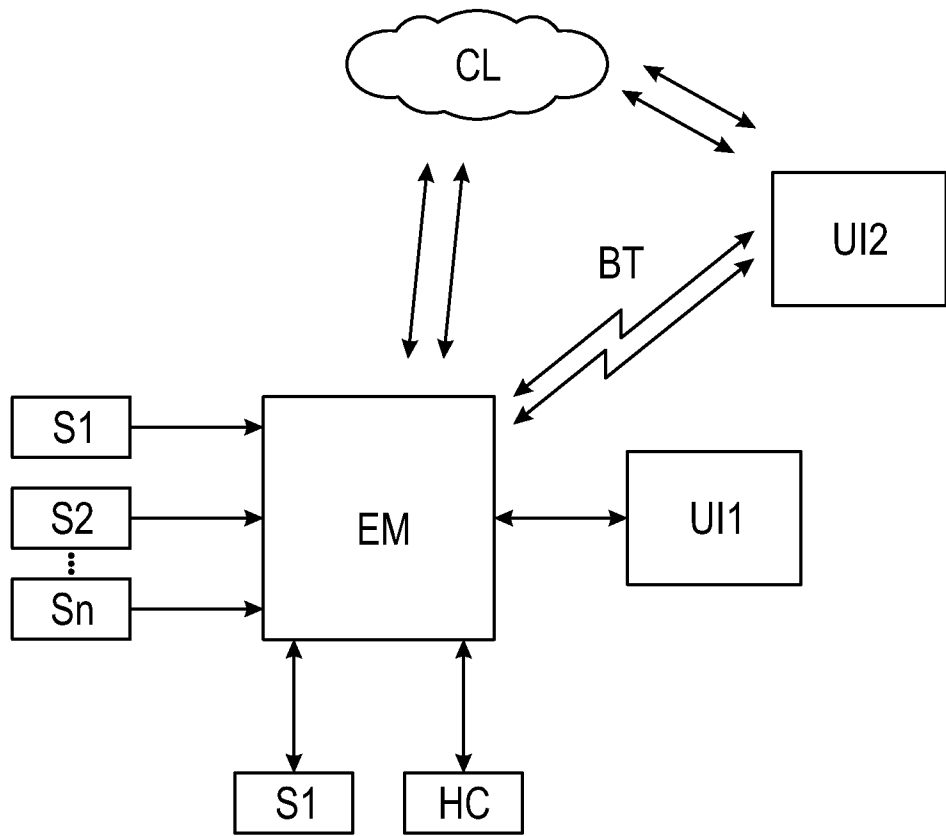

FIG. 22

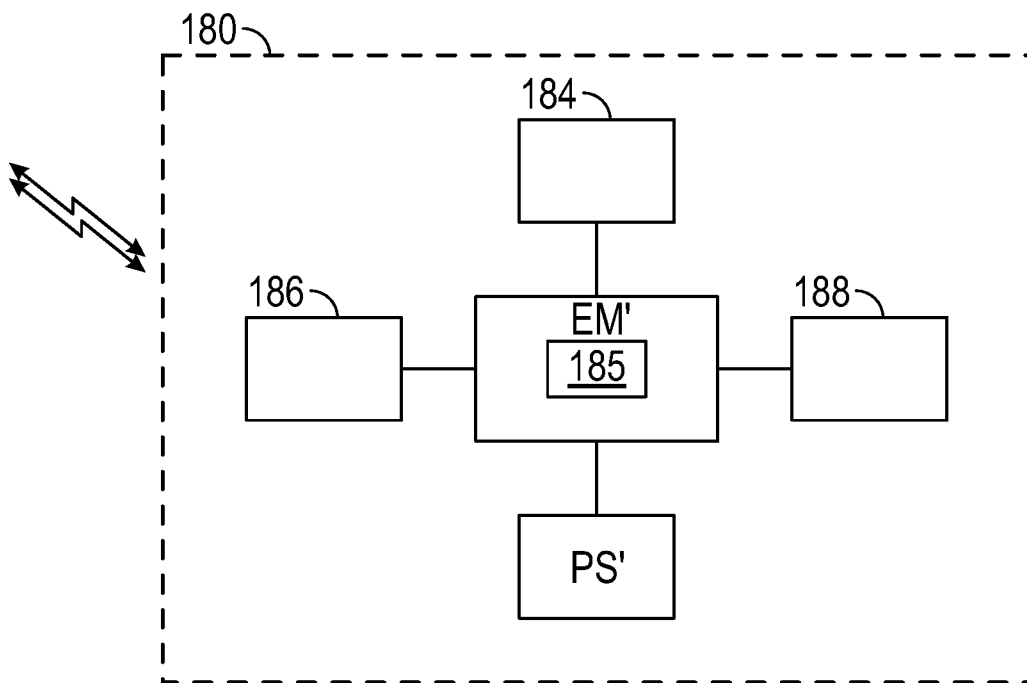

FIG. 23

18/25

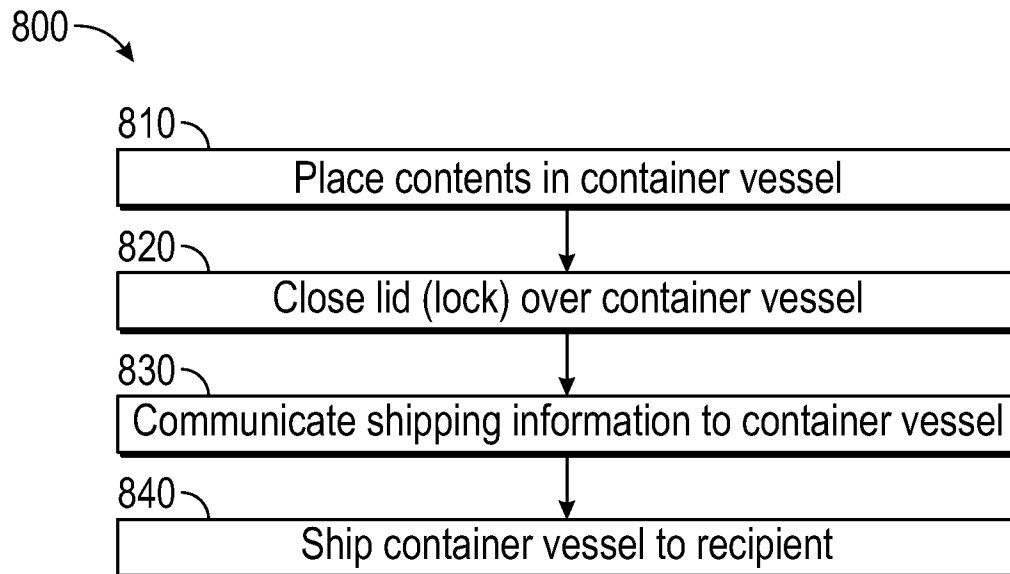

FIG. 24A

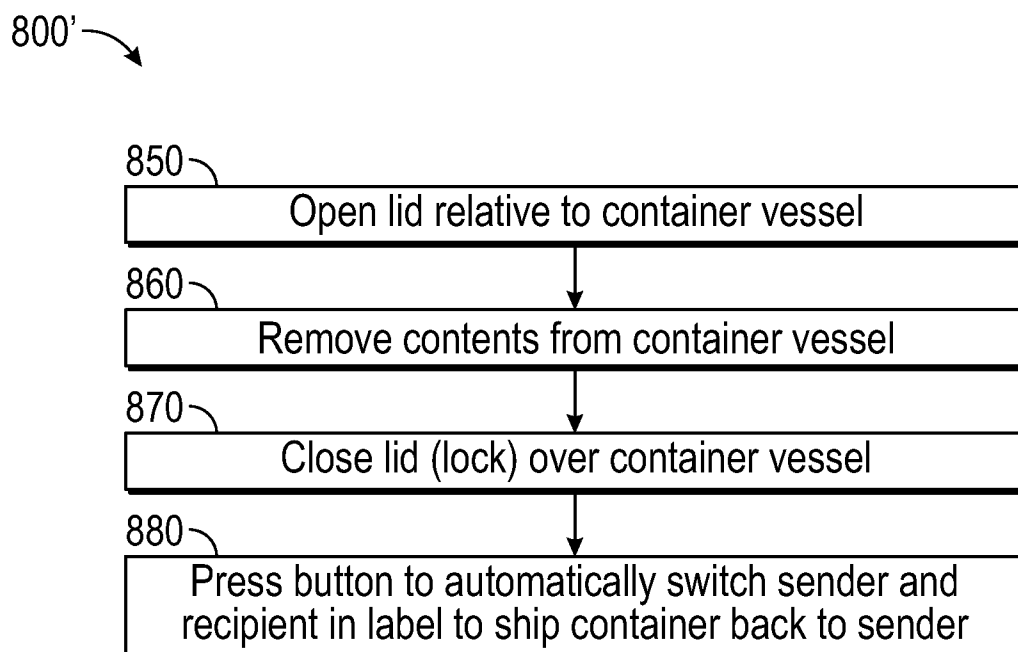

FIG. 24B

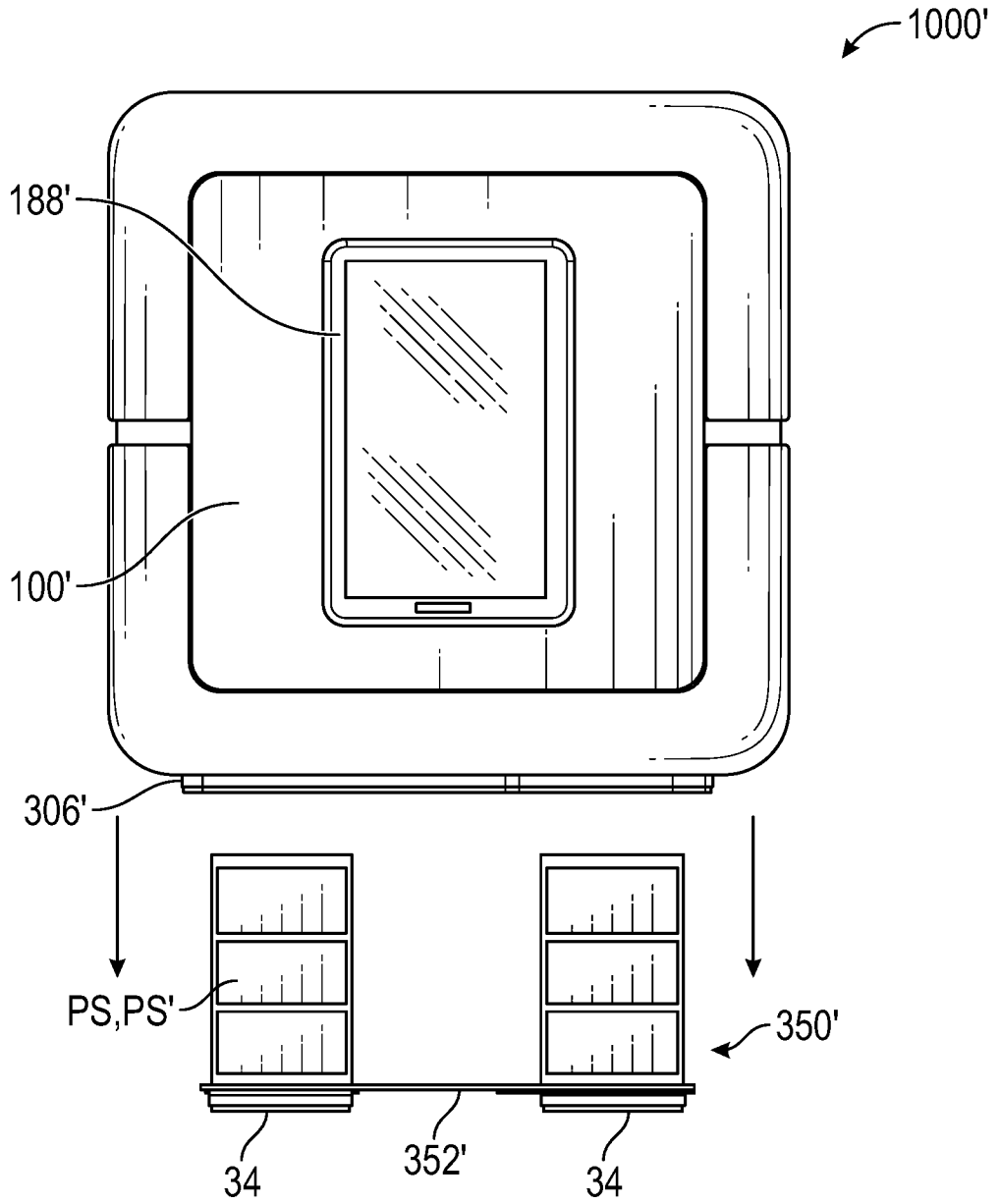

FIG. 25

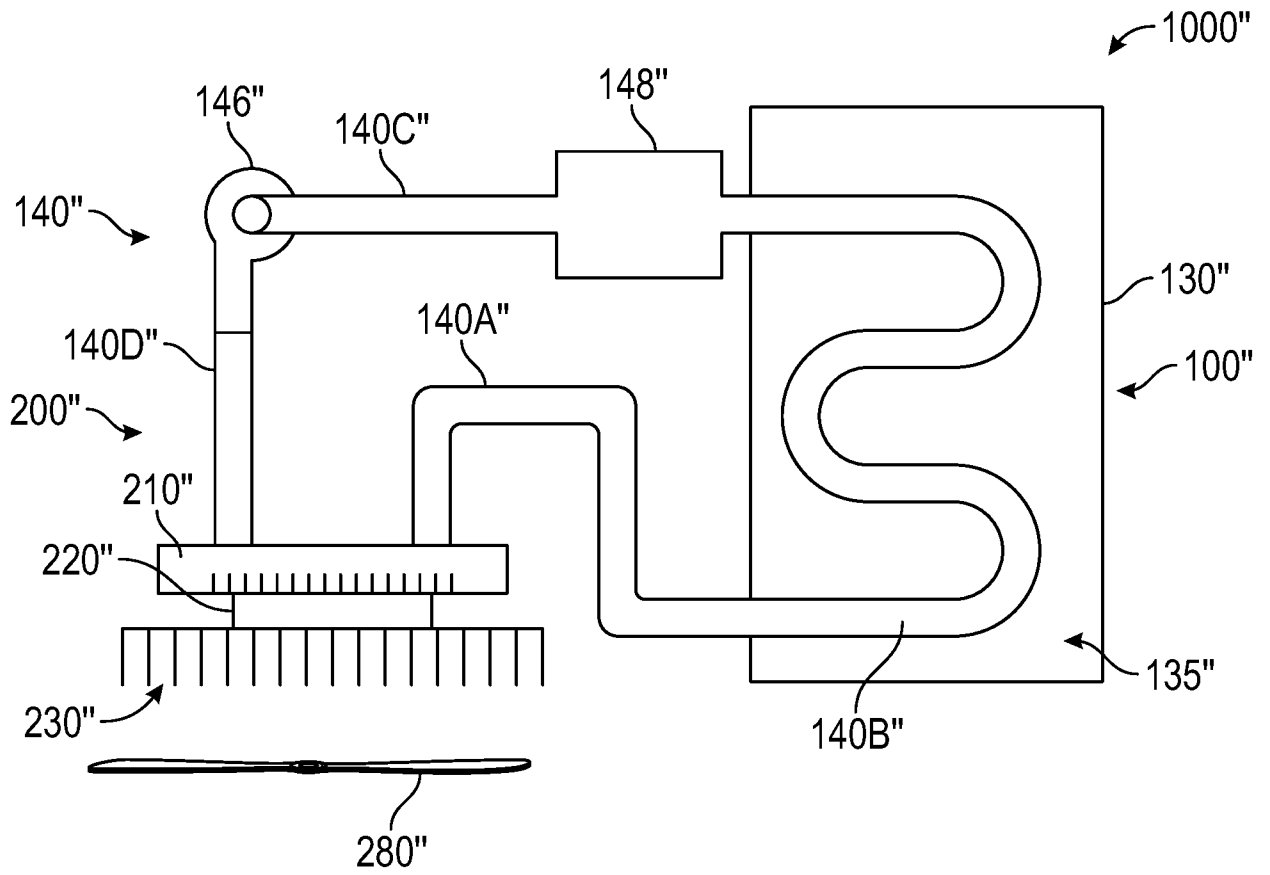

FIG. 26

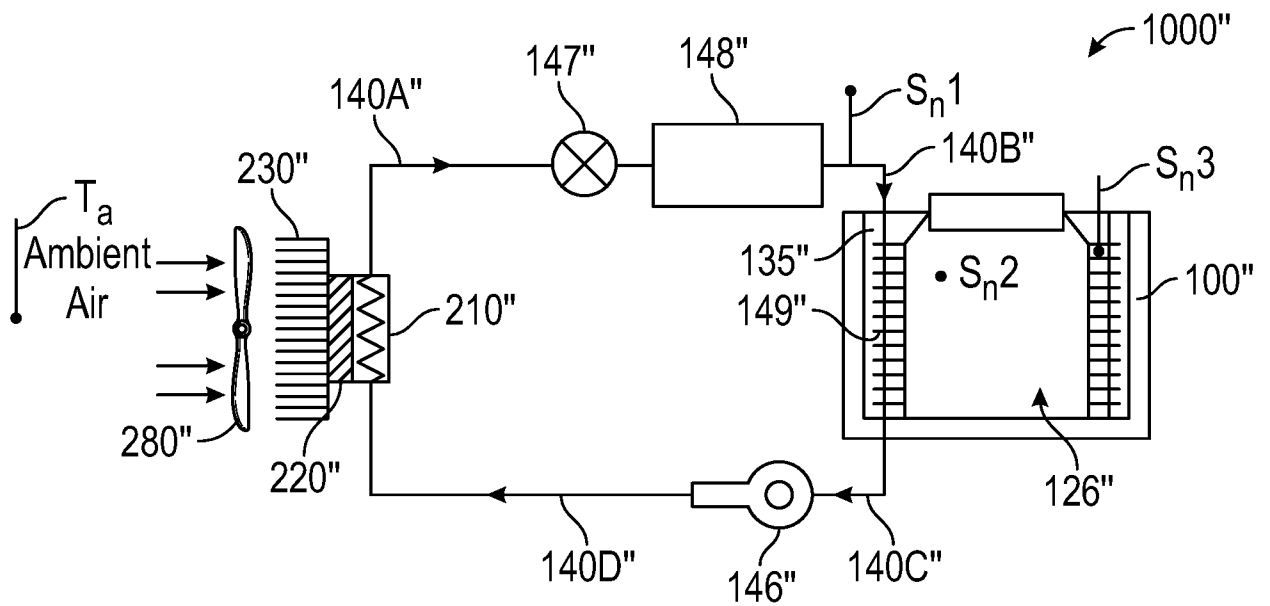

FIG. 27A

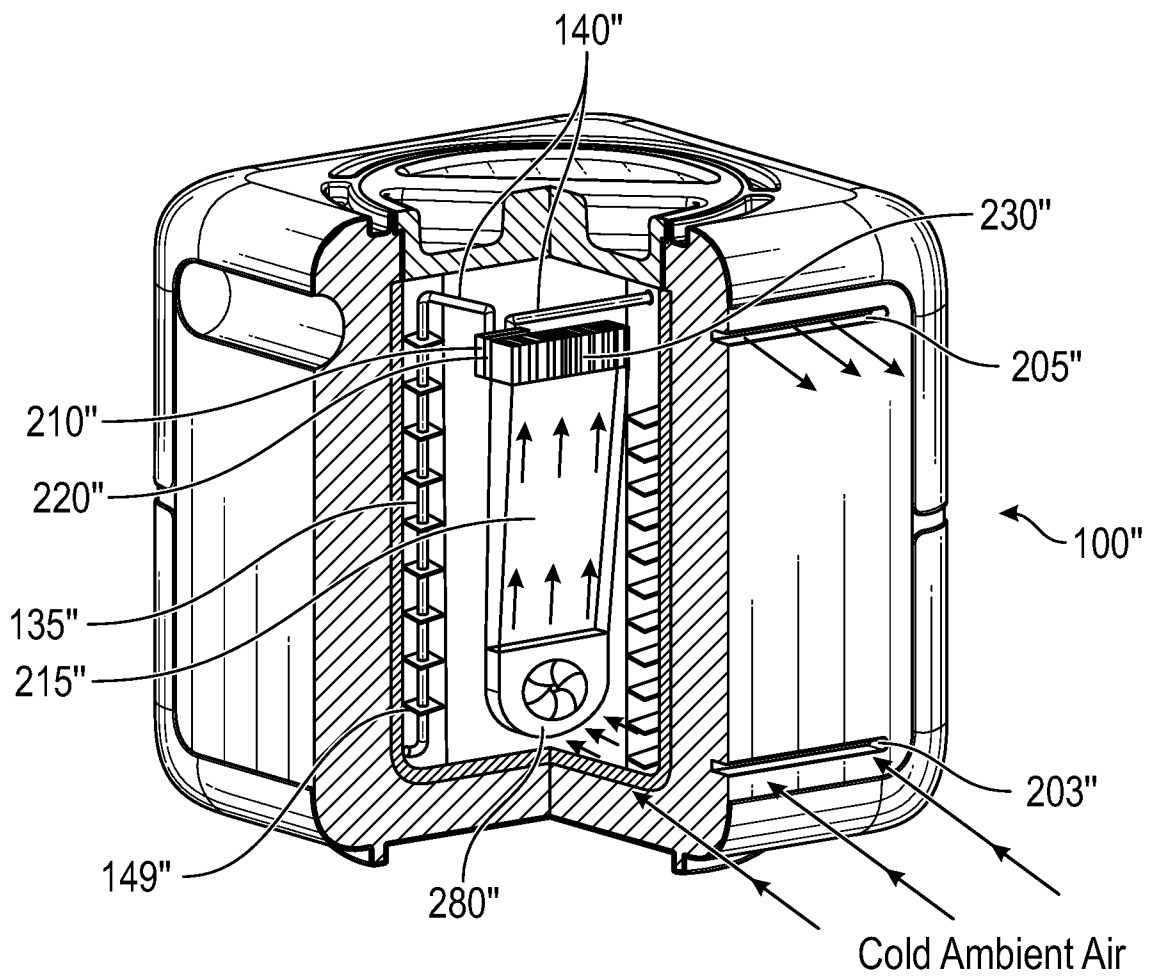

FIG. 27B

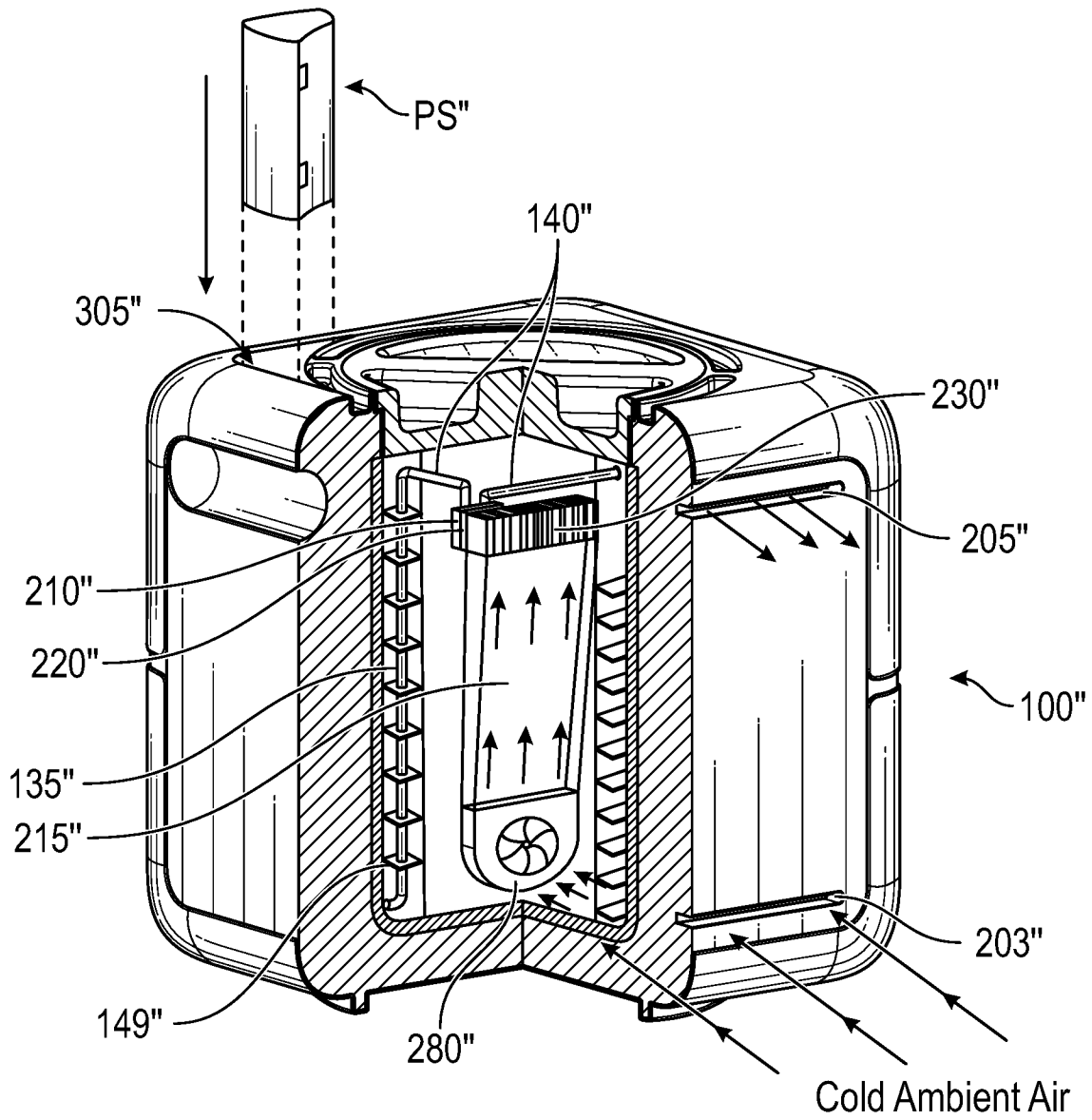

FIG. 27C

23/25

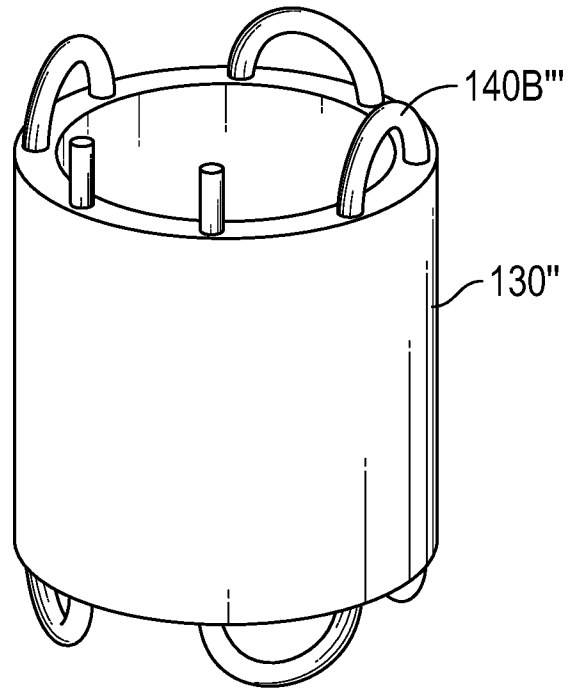

FIG. 28

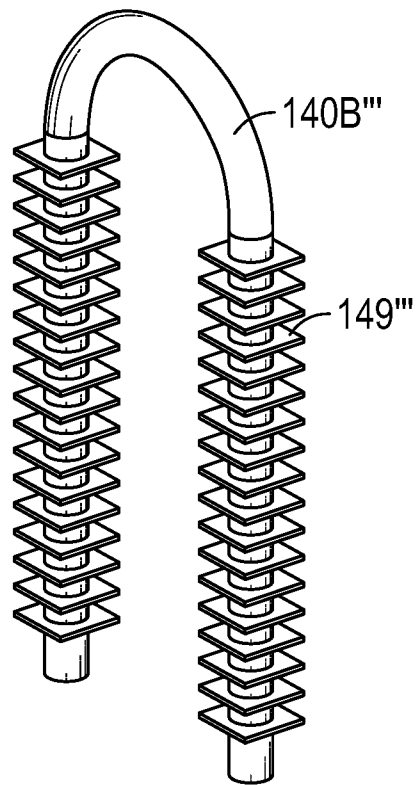

FIG. 29

24/25

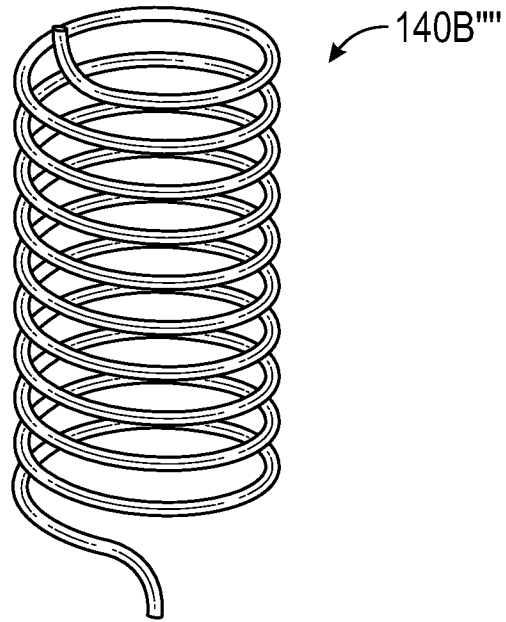

FIG. 30

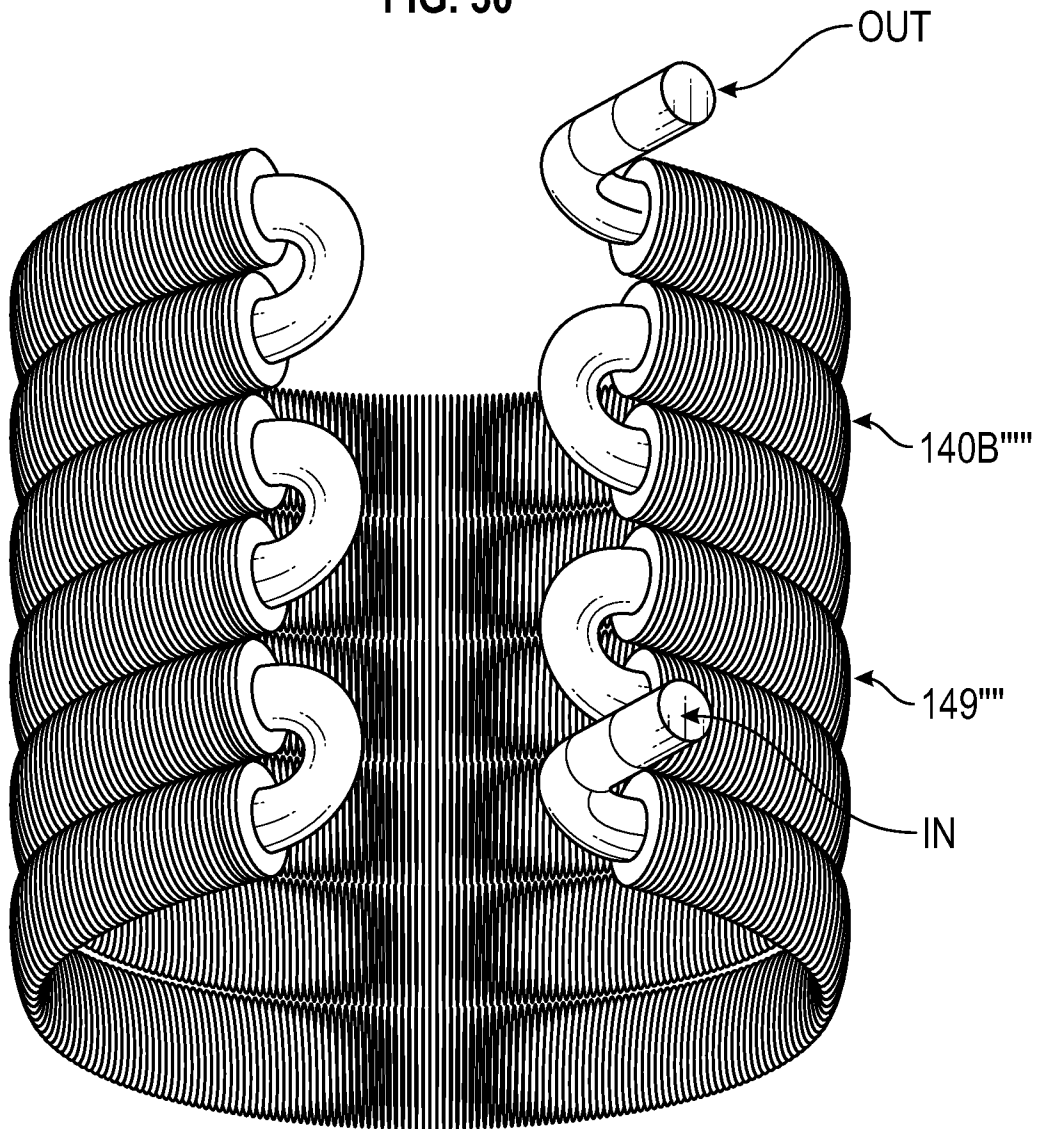

FIG. 31

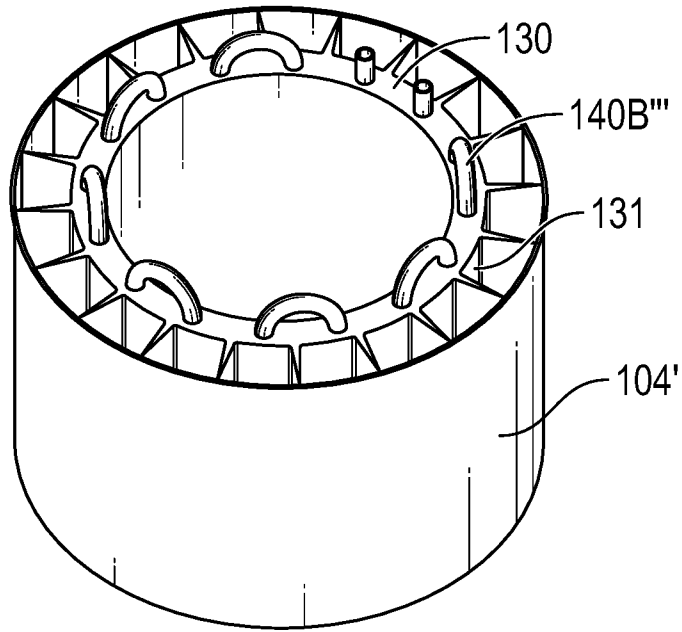

FIG. 32

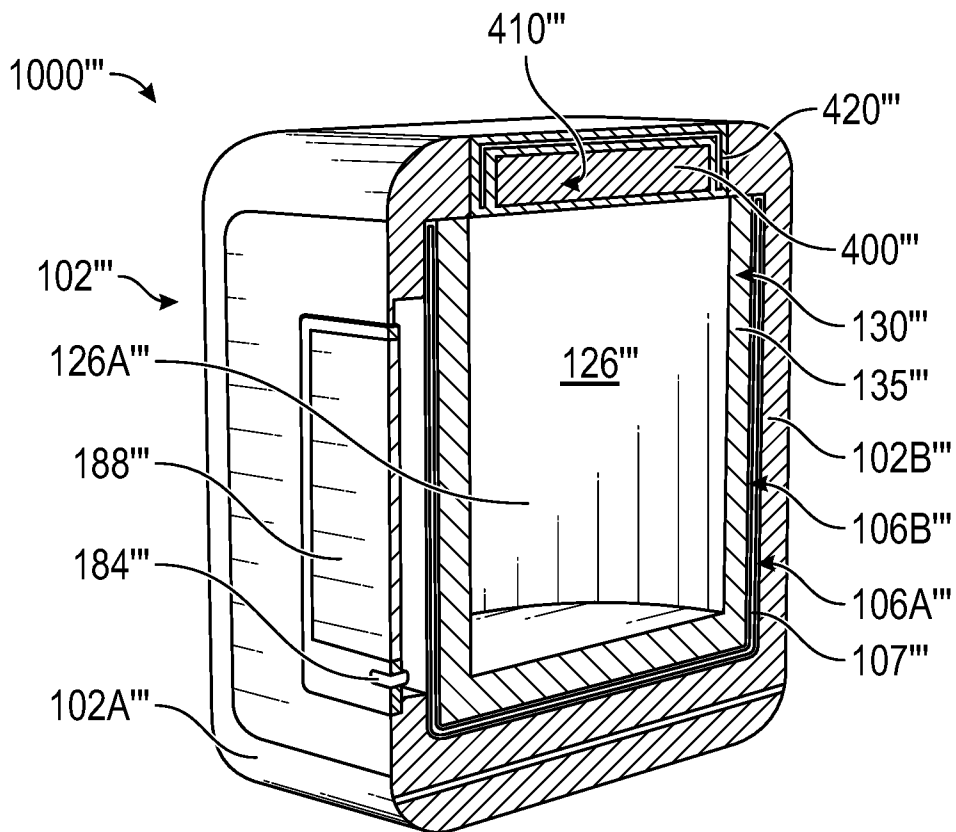

FIG. 33

INTERNATIONAL SEARCH REPORT

International application No
PCT/US2020/038765

A. CLASSIFICATION OF SUBJECT MATTER
INV. F25D3/08 F25B21/02
ADD.
According to International Patent Classification (IPC) or to both national classification and IPC

B. FIELDS SEARCHED
Minimum documentation searched (classification system followed by classification symbols)
F25D F25B
Documentation searched other than minimum documentation to the extent that such documents are included in the fields searched

Electronic data base consulted during the international search (name of data base and, where practicable, search terms used)
EPO-Internal, WPI Data

C. DOCUMENTS CONSIDERED TO BE RELEVANT		
Category*	Citation of document, with indication, where appropriate, of the relevant passages	Relevant to claim No.
X	KR 2015 0051074 A (KOREA FOOD RES INST [KR]) 11 May 2015 (2015-05-11)	1,9
Y	figures 1,3	2-4,6,7,11,12,18
A		5,8,10,13-17
Y	----- US 2017/290741 A1 (CHOU FONG-LI [US] ET AL) 12 October 2017 (2017-10-12) paragraph [0044]; figure 1	2,11
A	----- GB 2 304 179 A (FRASER MILNE LTD [GB]) 12 March 1997 (1997-03-12) figure 1	2
A	----- US 2011/041546 A1 (LINDER NATHAN [US]) 24 February 2011 (2011-02-24) figures 6-7	2
	----- -/--	

Further documents are listed in the continuation of Box C.

See patent family annex.

* Special categories of cited documents :

"A" document defining the general state of the art which is not considered to be of particular relevance

"E" earlier application or patent but published on or after the international filing date

"L" document which may throw doubts on priority claim(s) or which is cited to establish the publication date of another citation or other special reason (as specified)

"O" document referring to an oral disclosure, use, exhibition or other means

"P" document published prior to the international filing date but later than the priority date claimed

"T" later document published after the international filing date or priority date and not in conflict with the application but cited to understand the principle or theory underlying the invention

"X" document of particular relevance; the claimed invention cannot be considered novel or cannot be considered to involve an inventive step when the document is taken alone

"Y" document of particular relevance; the claimed invention cannot be considered to involve an inventive step when the document is combined with one or more other such documents, such combination being obvious to a person skilled in the art

"&" document member of the same patent family

Date of the actual completion of the international search 12 November 2020	Date of mailing of the international search report 23/11/2020
---	--

Name and mailing address of the ISA/ European Patent Office, P.B. 5818 Patentlaan 2 NL - 2280 HV Rijswijk Tel. (+31-70) 340-2040, Fax: (+31-70) 340-3016	Authorized officer Canköy, Necdet
--	--

INTERNATIONAL SEARCH REPORT

 International application No
 PCT/US2020/038765

C(Continuation). DOCUMENTS CONSIDERED TO BE RELEVANT		
Category*	Citation of document, with indication, where appropriate, of the relevant passages	Relevant to claim No.
Y	US 2017/177883 A1 (PATERRA FRANK [US] ET AL) 22 June 2017 (2017-06-22) paragraphs [0043], [0063] -----	3,4,12, 18
Y	US 2016/271015 A1 (WENGREEN SANDY [US] ET AL) 22 September 2016 (2016-09-22) paragraph [0277] -----	6,7,25
X	US 2017/314851 A1 (ALEXANDER CLAYTON [US] ET AL) 2 November 2017 (2017-11-02) paragraphs [0024], [0029], [0035] - Y A [0036], [0045], [0052] -----	19,20, 22-24 25 21
X	US 2017/042373 A1 (ALEXANDER CLAYTON [US] ET AL) 16 February 2017 (2017-02-16) paragraphs [0179], [0170], [0282], [0295] -----	19,20, 22,23

INTERNATIONAL SEARCH REPORT

International application No.
PCT/US2020/038765

Box No. II Observations where certain claims were found unsearchable (Continuation of item 2 of first sheet)

This international search report has not been established in respect of certain claims under Article 17(2)(a) for the following reasons:

1. Claims Nos.:
because they relate to subject matter not required to be searched by this Authority, namely:

2. Claims Nos.:
because they relate to parts of the international application that do not comply with the prescribed requirements to such an extent that no meaningful international search can be carried out, specifically:

3. Claims Nos.:
because they are dependent claims and are not drafted in accordance with the second and third sentences of Rule 6.4(a).

Box No. III Observations where unity of invention is lacking (Continuation of item 3 of first sheet)

This International Searching Authority found multiple inventions in this international application, as follows:

see additional sheet

1. As all required additional search fees were timely paid by the applicant, this international search report covers all searchable claims.

2. As all searchable claims could be searched without effort justifying an additional fees, this Authority did not invite payment of additional fees.

3. As only some of the required additional search fees were timely paid by the applicant, this international search report covers only those claims for which fees were paid, specifically claims Nos.:

4. No required additional search fees were timely paid by the applicant. Consequently, this international search report is restricted to the invention first mentioned in the claims; it is covered by claims Nos.:

Remark on Protest

- The additional search fees were accompanied by the applicant's protest and, where applicable, the payment of a protest fee.
- The additional search fees were accompanied by the applicant's protest but the applicable protest fee was not paid within the time limit specified in the invitation.
- No protest accompanied the payment of additional search fees.

FURTHER INFORMATION CONTINUED FROM PCT/ISA/ 210

This International Searching Authority found multiple (groups of) inventions in this international application, as follows:

1. claims: 1, 2, 6, 7, 9-11

A portable cooler with a coiled path

2. claims: 3-5, 8, 12-18

A portable cooler with a display screen

3. claims: 19-25

A portable cooler with a data storage system

INTERNATIONAL SEARCH REPORT

Information on patent family members

International application No PCT/US2020/038765

Patent document cited in search report	Publication date	Patent family member(s)	Publication date
KR 20150051074 A	11-05-2015	NONE	

US 2017290741 A1	12-10-2017	CN 109073309 A	21-12-2018
		EP 3443282 A1	20-02-2019
		JP 2019516944 A	20-06-2019
		KR 20180125028 A	21-11-2018
		SG 11201808320T A	30-10-2018
		TW 201740065 A	16-11-2017
		US 2017290741 A1	12-10-2017
		WO 2017180500 A1	19-10-2017
		ZA 201807462 B	26-02-2020

GB 2304179 A	12-03-1997	AU 6666196 A	12-03-1997
		GB 2304179 A	12-03-1997
		WO 9707369 A1	27-02-1997
		ZA 966779 B	19-02-1997

US 2011041546 A1	24-02-2011	NONE	

US 2017177883 A1	22-06-2017	US 2017177883 A1	22-06-2017
		US 2018225464 A1	09-08-2018
		US 2019354704 A1	21-11-2019

US 2016271015 A1	22-09-2016	NONE	

US 2017314851 A1	02-11-2017	US 2017314851 A1	02-11-2017
		US 2018202711 A1	19-07-2018
		WO 2017192396 A1	09-11-2017

US 2017042373 A1	16-02-2017	US 2017042373 A1	16-02-2017
		US 2018360264 A1	20-12-2018
