

C. W. MARTIN.
STEAM TRAP.

APPLICATION FILED MAR. 9, 1904.

2 SHEETS—SHEET 1.

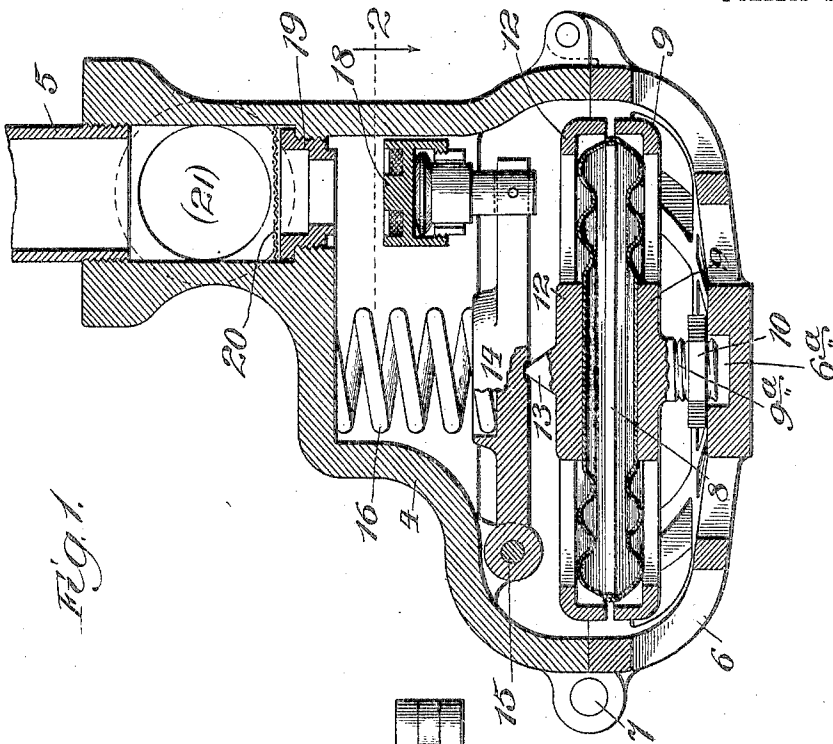

FIG. 1

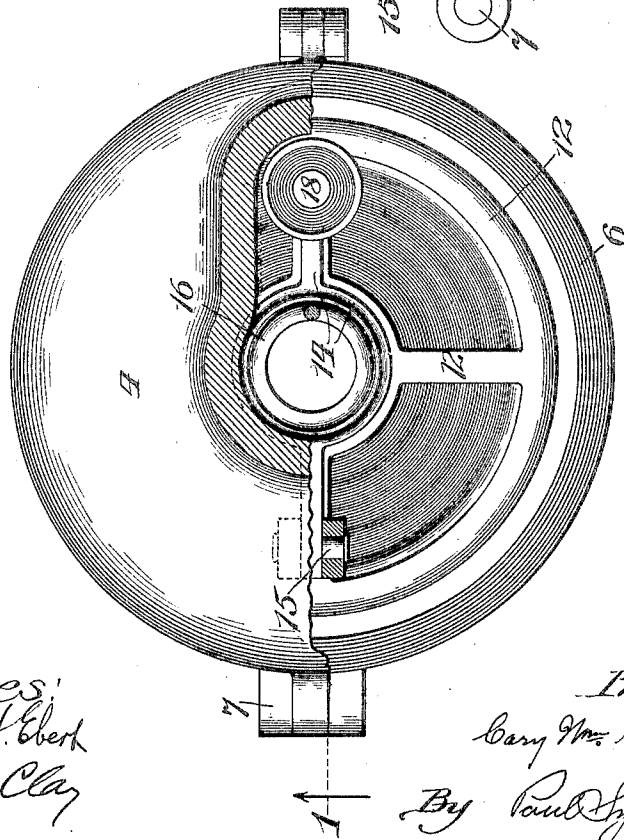
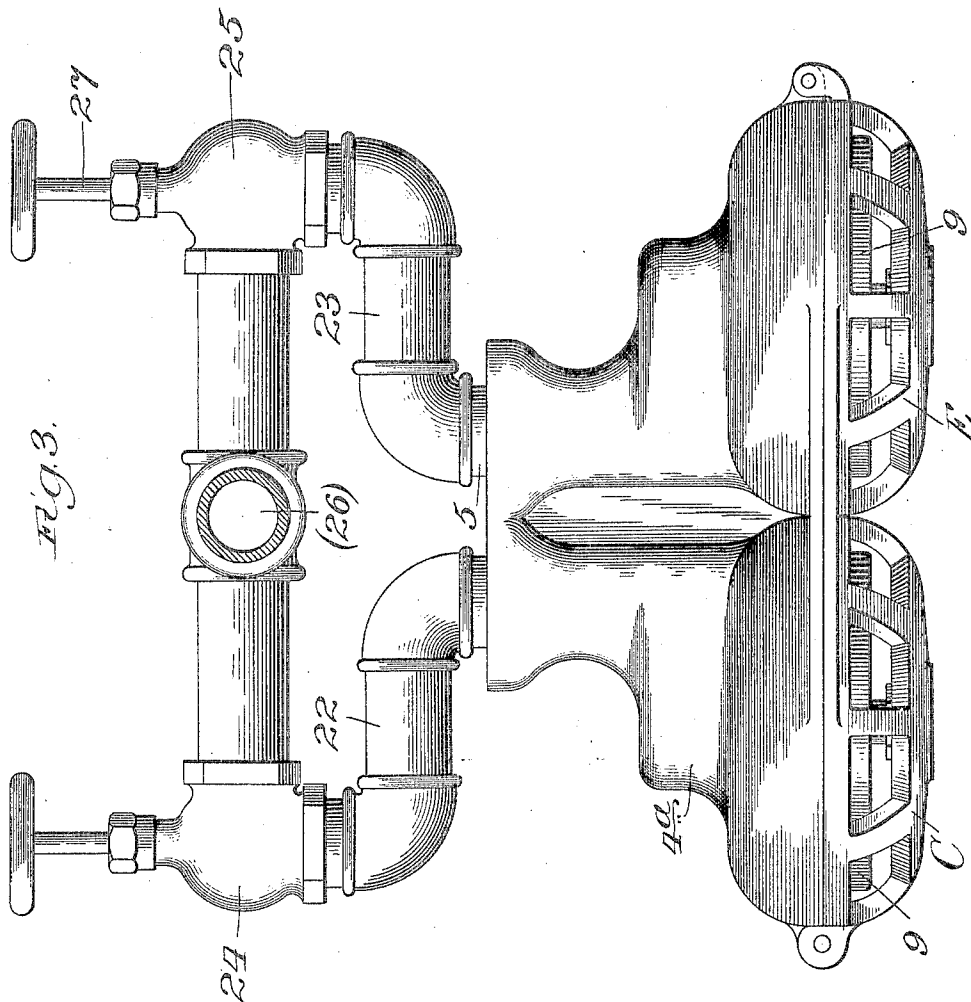

FIG. 2

Witnesses:
Chas. H. Ebert
F. W. H. Clay

Inventor:
Cary W. Martin
By Paul Lynestvedt
Atty

C. W. MARTIN.
STEAM TRAP.
APPLICATION FILED MAR. 9, 1904.



Witnesses:
 Chas. H. Eberk
 F. W. H. Clay

Inventor:
 Cary W. Martin
 By Paul Synnestvedt
 Att'y

UNITED STATES PATENT OFFICE.

CARY WILLIAM MARTIN, OF DUNKIRK, NEW YORK, ASSIGNOR TO MARTIN CAR HEATING COMPANY, OF CHICAGO, ILLINOIS, A CORPORATION OF WEST VIRGINIA.

STEAM-TRAP.

No. 802,461.

Specification of Letters Patent.

Patented Oct. 24, 1905.

Application filed March 9, 1904. Serial No. 197,359.

To all whom it may concern:

Be it known that I, CARY WILLIAM MARTIN, a citizen of the United States, residing at Dunkirk, Chautauqua county, and State of New York, have invented certain new and useful Improvements in Steam-Traps, of which the following is a specification.

My invention relates to steam-traps for use in car-heating apparatus and the like, and particularly to that form of steam-trap in which the outlet is controlled by a fluid-pressure-controlled diaphragm or equalizer.

The objects of the invention are to provide a compact and simple steam-trap which will be more efficient than those heretofore constructed, to provide an extremely sensitive means for moving the valve of the trap and adjustable means for controlling the pressure-diaphragm, to simplify the movable parts and make a more compact mechanism in devices of the kind specified, and to generally improve the structure and operation of steam-traps. These objects, together with other advantages which will hereinafter appear, I attain by means of the construction illustrated in preferred form in the accompanying drawings, wherein—

Figure 1 is a vertical central section through the steam-trap, the same being taken on line 1 of Fig. 2. Fig. 2 is a top plan view in partial horizontal section through the casing of the steam-trap, taken on line 2 in Fig. 1; and Fig. 3 shows a modified form of the valve-casing for the purpose of utilizing a pair of traps together, one for each side of a car with a T-valve attached, so either can be used for either side.

Referring first to Figs. 1 and 2, it will be seen that I have provided a casing 4, which has a steam-pipe 5 entering in the valve-neck at the top of the same. The bottom of the casing is closed by means of a grating 6, which is pivoted to the casing at 7 and has a recessed seat 6^a, upon which rests the nut 10 on the stem 9^a of the base 9 of the fluid-pressure-diaphragm chamber 8, contained in the casing 10. The top of the diaphragm or thermostatic cell 8 containing the fluid is supplied with a plate 12, which carries the pivot-point 13, supporting near its center the lever 14, which latter is pivoted at 15 to the casing 4 of the valve and is pressed downward normally upon the pivot 13 by means of the coil-spring 16. At its farther end this lever

14 carries the stem 17 of the valve 18, and it will be seen that this operates vertically to seat itself upon the seat 19 in the top of the casing communicating with the pipe 5 and the opening 21. Above the valve-seat 19 is the screen 20, which serves as a strainer for the protection of the trap. It will be observed that by this construction the motion of the valve 18 to and from its seat in the trap will be considerably greater than the motion of the top plate 12 of the diaphragm and that the motion of the valve will therefore be much more sensitive than it would be if the valve 10 were connected directly to the plate on top of the diaphragm or equalizer. By means of the nut 10 on the stem 9^a the pressure between the diaphragm and the lever 14 may be controlled as desired and the parts accurately adjusted for extreme sensitiveness. It will be understood that the valve 18 ordinarily stands open for the free drainage of the water and condensing vapor; but when steam begins to escape the fluid in the equalizer or diaphragm 8 becomes heated and expands, raising the lever 14 against the spring 16 and closing the valve 18 on its seat. It remains closed until the diaphragm cools again, when it is opened by the water or steam assisted by the spring 16, as will be clear.

In Fig. 3 I have shown a side elevation of a twin casing which it will be understood is similar to a pair of casings shown in Fig. 1, except that the casing is cast in one piece, and each side thereof contains the same mechanism as shown in Fig. 1. At the top of the casing 4^a I provide a pair of pipes which it will be seen by pipes 22 and 23 are connected indirectly with the steam-outlet 26, and each side is controlled by means of a cock 24 and 25. The outlet is therefore controlled by two traps, or either of them, so that if one gets out of order the other may operate for both sides or either side of the car.

Having thus described my invention and illustrated its use, what I claim as new, and desire to secure by Letters Patent, is the following:

1. In a steam-trap the combination of a twin chamber-casing, a fluid-pressure-operated valve in each chamber and valve-controlled connections from each chamber and valve to the steam-pipe, whereby either trap-valve may operate to control the steam-pipe.

2. In a steam-trap of the class described, a

casing to contain a thermostatic cell and a valve and which is open at the bottom, in combination with a grating hinged to the casing and normally closing the bottom thereof, a thermostatic cell or diaphragm mounted upon said grating for movement therewith with respect to said casing, a pivot-plate resting upon said cell, a lever resting upon said pivot-plate and pivoted upon the inner wall of said casing above said cell, a spring-seat provided upon the top of said lever, a spring arranged between the top of the casing and said spring-seat, a valve mounted upon the free end of said lever, and a valve-seat provided in the top of said casing against which said valve is adapted to be closed by the expansion of said cell, substantially as described.

3. In a steam-trap of the class described, a casing to contain a thermostatic cell, in combination with a grating hinged to said casing and closing the bottom thereof, a thermostatic cell or diaphragm mounted within said grating, a pivot-point plate resting upon said cell, said cell and pivot-point plate being removable from the casing with said grating when the latter is opened, a valve-lever having its end pivoted upon the inner wall of said casing above said cell, said lever resting upon said pivot-point plate and being provided with an enlarged spring-seat portion upon its top, said casing having an eccentrically-located neck on its top to receive a steam-pipe, a valve-seat provided at the base of said neck, a valve loosely mounted on the free end of said lever to close against said valve-seat, and a spring arranged in the upper part of the casing and resting in the spring-seat of said lever, substantially as described.

4. In a steam-trap, a casing to contain a thermostatic cell and a valve, in combination with a grating hinged to said casing and closing the bottom thereof, a thermostatic cell adjustably mounted on said grating and substantially wholly contained within said grating, a pivot-plate provided upon the top of said cell, a valve-lever pivoted upon the inner wall of said casing and extending across the pivot-plate of said cell for operation thereby, said casing having an elongated eccentric chamber in its upper part and provided with an eccentrically-located neck communicating with said chamber, a spring arranged in said chamber and pressing upon said lever centrally above said thermostatic cell, and a valve mounted upon the end of said lever for closing said neck, substantially as described.

5. In a steam-trap of the class described, a casing containing a circular chamber open at the bottom and an overlying horizontal elongated spring and valve chamber, in combination with a grating hinged upon said casing and closing the bottom thereof, a valve-lever hinged upon the inner wall of said casing, a spring provided in said elongated chamber and pressing upon said lever, said casing

having a neck provided with a valve-seat communicating with the top of said elongated chamber, a valve loosely mounted upon and rising from the free end of said lever to close against said valve-seat, and a suitably-inclosed thermostatic cell interposed between said lever and said grating, substantially as described.

6. In a steam-trap of the class described, a casing to contain a valve and a thermostatic cell, in combination with a hinged grating forming the bottom of said casing, a thermostatic cell loosely mounted upon said grating, means for adjusting said cell vertically, plates inclosing said cell, a valve-lever hinged upon the inner wall of said casing and resting upon the upper cell-inclosing plate, said casing having an eccentrically-located neck containing a valve-seat, and a spring and valve, pressing against, and mounted upon, the top of said lever, said valve being adapted to close against said seat, substantially as described.

7. In a steam-trap of the class described, a substantially circular casing provided with an eccentrically-located neck and having a horizontal elongated eccentric chamber between said neck and the lower part of the casing, in combination with a valve-seat arranged in the opening between said neck and said chamber, a valve-lever pivoted upon the inner wall of said casing, a spring arranged in the central part of said chamber, a central spring-seat upon said lever, a valve mounted upon the free end of the lever beneath said valve-seat and within said chamber, and a thermostatic cell centrally arranged in said casing and supporting said lever and the valve thereon, substantially as described.

8. In a steam-trap of the class described, a casing containing a circular chamber and a horizontal elongated eccentric chamber and provided with an eccentric neck, in combination with a grating hinged upon the casing and closing the bottom thereof, a cell-plate mounted upon said grating, a thermostatic cell resting upon said plate, an upper cell-plate resting upon said cell and provided with a pivot-point 13, a lever having a spring-seat upon its top and having its end pivoted on the inner wall of said casing, a spring arranged in said elongated chamber above said spring-seat, a valve arranged upon the free end of said lever above said thermostatic cell, and a valve-seat in the opening between said neck and elongated chamber, substantially as described.

9. In a steam-trap of the class described, a casing, in combination with a grating hinged thereto and closing the bottom thereof, said casing having a neck containing a valve-seat, a spring-pressed valve-lever and valve thereon to close against said seat, thermostatic cell-plates, 9 and 12, the latter having a pivot-point, bearing said lever, and a thermostatic cell arranged between said plates, said plates

having flanges which circumferentially in-
close said cell, substantially as described.

10. A steam-trap having a casing, in com-
bination with a grating hinged thereto and
5 closing the bottom thereof, said casing having
a central opening, 6^a, a cell or diaphragm
plate, 9, having a central stud loosely arranged
in said opening, 6^a, an adjusting-nut on said
stud for supporting said plate on said grating,
10 a thermostatic cell resting upon said plate, an
upper cell-plate, and a spring-resisted valve
arranged to be operated by the expansion and
contraction of said cell between said plates,
substantially as described.

15 11. In a steam-trap, a casing containing
two chambers, each provided with a steam-
pipe connection at the top, a grating hinged
upon said casing for closing the bottoms of
both said chambers, valves provided within
20 said chambers and thermostatic cells mounted
upon said grating for actuating said valves
respectively, as and for the purpose specified.

12. In a steam-trap of the class described,
a casing provided with an eccentrically-lo-
cated neck, containing a valve-seat, in com- 25
bination with a suitably-perforated bottom
for said casing, a valve in said casing in ver-
tical alinement with said neck and seat, a hori-
zontal valve-lever to one end of which said
valve is attached, a pivot on the wall of said 30
casing for the opposite end of the lever, a
spring-seat upon the top of said lever, a spring
pressing thereon, and a thermo-expansion de-
vice suitably mounted upon the perforated
bottom of the casing and having a pivot-point 35
on the top to engage a point-socket in the bot-
tom of said lever, substantially as described.

In testimony whereof I have hereunder
signed my name in the presence of the two
subscribed witnesses.

CARY WILLIAM MARTIN.

Witnesses:

PAUL CARPENTER,
EDWARD C. BURNS.