

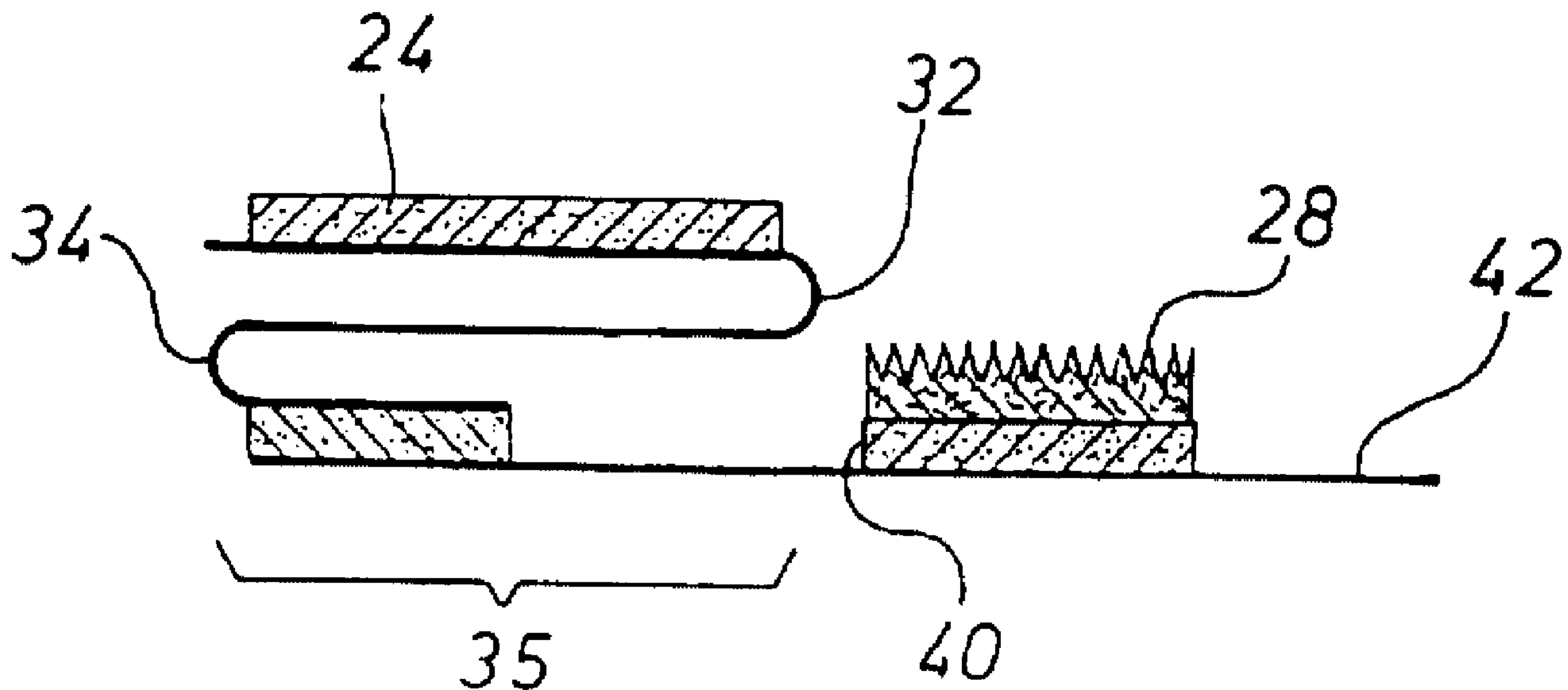

(86) Date de dépôt PCT/PCT Filing Date: 2002/06/24
 (87) Date publication PCT/PCT Publication Date: 2003/02/27
 (45) Date de délivrance/Issue Date: 2011/01/04
 (85) Entrée phase nationale/National Entry: 2004/02/10
 (86) N° demande PCT/PCT Application No.: EP 2002/006946
 (87) N° publication PCT/PCT Publication No.: 2003/015675
 (30) Priorité/Priority: 2001/08/18 (DE101 40 622.3)

(51) Cl.Int./Int.Cl. *A61F 13/62* (2006.01)
 (72) Inventeurs/Inventors:
 WENDELSTORF, CARSTEN, DE;
 MANGOLD, RAINER, DE
 (73) Propriétaire/Owner:
 PAUL HARTMANN AG, DE
 (74) Agent: GOWLING LAFLEUR HENDERSON LLP

(54) Titre : ARTICLE D'HYGIENE POURVU D'ELEMENTS DE FIXATION
 (54) Title: HYGIENE ARTICLE WITH FASTENING ELEMENTS



(57) **Abrégé/Abstract:**

The invention relates to a hygiene article, particularly a diaper also for incontinence, comprising a protective layer, which is permeable to fluid, a rear layer, which is impermeable to fluid, and an absorbing body, arranged between said layers. Said hygiene article also comprises fastening elements (2), for removably fastening the hygiene article, when worn by a user. Said article has a first longitudinal direction (12) and a second transverse direction (14). The fastening elements (2) each comprise a clip means (27) and said clip means (27) cooperates with an application zone (55) of the hygiene article. Each fastening element (2) has a first zone (22), by means of which the fastening element can be attached to the hygiene article, and a second zone (26), arranged at a distance from the first zone (22) in the transverse direction (14) and in which the clip means (27) is provided. Each fastening element is folded in a zigzag manner along folding lines (32,34), extending in the longitudinal direction (12). In order to improve production and manipulation thereof, the second zone, (26), provided with said clip means (27), is arranged outside of the zigzag folded configuration (35) in the transverse direction (14).

Abstract of the Invention

The invention relates to a hygiene article, particularly a diaper also for incontinence, comprising a protective layer, which is permeable to fluid, a rear layer, which is impermeable to fluid, and an absorbing body, arranged between said layers. Said hygiene article also comprises fastening elements (2), for removably fastening the hygiene article, when worn by a user. Said article has a first longitudinal direction (12) and a second transverse direction (14). The fastening elements (2) each comprise a clip means (27) and said clip means (27) cooperates with an application zone (55) of the hygiene article. Each fastening element (2) has a first zone (22), by means of which the fastening element can be attached to the hygiene article, and a second zone (26), arranged at a distance from the first zone (22) in the transverse direction (14) and in which the clip means (27) is provided. Each fastening element is folded in a zigzag manner along folding lines (32,34), extending in the longitudinal direction (12). In order to improve production and manipulation thereof, the second zone, (26), provided with said clip means (27), is arranged outside of the zigzag folded configuration (35) in the transverse direction (14).

Hygiene Article with Fastening Elements

Description

The invention relates to a hygiene article, also particularly a diaper for incontinence, having a fluid-pervious top sheet, a fluid-impervious back sheet and an absorbent core disposed therebetween, and having fastening elements for releasably closing the hygiene article when applied to the user, where the hygiene article has a first longitudinal direction and a second transverse direction, where the fastening elements have securing means and the securing means coact with a contact zone on the hygiene article, and where the specific fastening element has a first zone, by which it is attached to the hygiene article, and a second zone which is spaced apart from the first zone in the transverse direction and in which the securing means are furnished, where the specific fastening element is folded in a Z-shape, with fold lines running in the longitudinal direction.

Hygiene articles with fastening elements folded over on themselves prior to use are known, for example, from EP 0 669 121 A1 or WO 95/16425. Fastening elements folded over on themselves in a Z-shape for disposable hygiene articles are also known from U.S. patent 4, 237,890.

Based on this prior art, the object of the present invention is to improve a hygiene article of the said type with respect to ease of attachment of the fastening elements during manufacture of the hygiene article, but also to

WO 03/015675

2

PCT/EP02/06946

simplify the handling of the hygiene article after the fastening elements are attached in a high-speed production machine and during a subsequent packaging process. A further object of the present invention is to improve the manageability of the hygiene article during unfolding, positioning and closing of the fastening elements when the hygiene article is attached to a user.

This object is achieved by a hygiene article of the type described in accordance with the invention by placing the second zone having the securing means outside the folded, Z-shaped configuration in the transverse direction.

The present invention accordingly proposes to fold the fastening element in the longitudinal direction in such a way that the result is a Z-shaped configuration, of which one part, or section, of the fastening element which has the second zone with the securing means projects transversely, is thus located outside the folded, Z-shaped configuration. In this way it is possible to affix, i.e. to attach, the particular fastening element with its first zone on a surface of the hygiene article. The part or section of the fastening element projecting at the side, in the transverse direction from the folded Z-shaped configuration, can now be grasped easily under the invention. Since the gummy or otherwise adhesively configured securing means is furnished there, advantages also accrue with respect to manufacture; the securing means is prevented from interfering in a distracting fashion with the folded, Z-shaped configuration.

In a further embodiment of the invention, the particular fastening element with a zone lying outside the folded, Z-shaped configuration forms a releasable retentive connection with the top side of the hygiene article by providing adhesive or retaining means. For example, the second section of the fastening

WO 03/015675

3

PCT/EP02/06946

element could have spots of glue at any location which adhere to the top side of the hygiene article in an easily releasable manner and thus retain the fastening element in the intended assembled position. It would also be conceivable that the second zone, which has the active securing means, is overlaid with a detachable covering which in turn has an adhesive coating to releasably retain the section to the top side of the hygiene article.

However, in a further embodiment of the invention it is proposed that the releasable retentive connection is formed by the securing means in the second zone of the fastening element itself.

It also proves to be advantageous if the particular securing means is formed by mechanically acting closures. To create a releasable retentive connection, they can coact with a textile-like top side of the hygiene article, for example in the manner of a hook-and-loop material.

With respect to the attachment of the fastening elements to the hygiene article, an arrangement on the inner user facing side, that is, on the side of the fluid-pervious top sheet, could be considered, or an attachment by means of fork-shaped or Y-shaped retaining tabs, which clasp the combined top sheet and back sheet of the hygiene article from both sides and are attached there.

However, in embodying the present invention, it proves to be particularly advantageous if the fastening elements are attached to a side of the hygiene article facing away from the body.

The side facing away from the body can advantageously have a textile-like surface. This textile-like surface advantageously comprises the fluid-

impervious back sheet and can be made from a nonwoven-plastic film laminate. In this embodiment it is possible to implement the releasable retentive connection through mechanically acting closures which are located outside the folded, Z-shaped configuration and coact directly with the textile-like surface in an adherent manner.

In accordance with a further especially preferred embodiment of the invention, the folded, Z-shaped fastening elements are spaced apart in the transverse direction from a longitudinal edge of the hygiene article in such a way that the second zone with the securing means is located at least almost entirely inside the longitudinal edge. This is intended to convey that the second zone with the securing means should protrude as little as possible, preferably not at all, beyond the longitudinal edge of the hygiene article. This is to prevent the protruding area of the securing means from catching on the top sheet when the hygiene article is folded onto the body facing top sheet and damaging said top sheet when it is detached. The second zone should not protrude outwardly more than 5 mm, preferably less than 3 mm, most specifically less than 2 mm in the transverse direction beyond the longitudinal edge. When the side sections of the rear area of the hygiene article, often described as "ears" and carrying the fastening elements, are folded in on the body facing top sheet as part of the folding of the hygiene article during manufacture, this prevents the particular securing means from becoming entangled with the surface of the normally fleecy top sheet and damaging said top sheet. Furthermore, fleecy material could become stuck on the securing means and negatively affect the closing ability of the mechanically acting closures.

In a further embodiment of the invention it is proposed to configure the

WO 03/015675

5

PCT/EP02/06946

fastening elements in such a way that a pull tab is furnished for the user to take hold of with a finger. The pull tab is furnished in the transverse direction outside the second zone of the particular fastening element and on the side of the second zone facing away from the folded, Z-shaped configuration. In yet another embodiment of this inventive concept, the fastening element is positioned on the surface of the hygiene article facing away from the body and attached there in such a way that its pull tab protrudes beyond a longitudinal edge of the hygiene article in the transverse direction. This proves to be advantageous insofar as with the hygiene article spread out and unfolded, the particular fastening element with its pull tab projects in the transverse direction beyond the longitudinal edges of the hygiene article on both sides and they are thus visible. They can then be easily grasped by a user's fingers, who takes hold of the pull tab with one hand, and with the other hand, perhaps with thumb and forefinger, takes holds of a longitudinal edge area of the hygiene article and then exerts a pulling motion. The releasable retentive connection between the fastening element and the surface of the diaper is thereby broken and the folded, Z-shaped configuration is unfolded, so that the fastening element can be moved in a direction encircling the hips towards the contact zone provided in the front area of the hygiene article, to be secured there to close the hygiene article when applied to a user.

The particular fastening element can have a first section of a first supporting layer and a second section of a second supporting layer which is disposed in the transverse direction next to the first section and is connected thereto. The first section has the first zone and the second section has the second zone.

It proves to be advantageous if a fold line of the fastening element running in

WO 03/015675

6

PCT/EP02/06946

the longitudinal direction runs at least in sections along a material transition between the first and second section of the fastening element. The ability of the fastening element to be folded is thereby improved, and the thickness of the folded, Z-shaped configuration is kept as small as possible.

Preferably the fold line runs immediately along a longitudinal edge of the second section of the fastening element.

The first and the second section of the particular fastening element can be joined in any way whatsoever, they could butt against each other and be overlaid by a third, specifically strip-shaped, fastening element which joins the two sections non-detachably. It is also conceivable and advantageous for the first and the second section of the fastening element to be overlapped in the transverse direction and be joined in the overlap area. In this case, it proves advantageous if a fold line of the fastening element running in the longitudinal direction runs immediately along a longitudinal edge of the first zone.

In a further embodiment of the invention, it proves advantageous if a further fold line of the folded, Z-shaped configuration runs immediately along a longitudinal edge of an adhesive coating in the first zone. The adhesive coating of the first zone can be of any areal extent, where to achieve very good securing of the folded, Z-shaped configuration on the top side of the hygiene article, as extensive an application of adhesive as possible, specifically delineated as a rectangle in plan view, is recommended.

It furthermore proves advantageous if the second supporting layer of the fastening element comprises an essentially inelastic material and is essentially

not extensible in the transverse direction. In contrast, it is proposed that the first supporting layer of the fastening element comprises a material essentially extensible at least in the transverse direction and is configured elastically extensible in this transverse direction.

As used herein, elastically extensible refers to a material which can be stretched by at least 1.2 times its original dimension when tension is applied and, when tension is removed, contracts again at least far enough to nullify at least half of the stretched length. Of course, materials are known and preferred for use as the first supporting layer which demonstrate much more pronounced retraction characteristics.

To achieve these elastically extensible properties for the first supporting layer, elastic nonwovens or so-called "stretchbond" laminates with one or more nonwoven and/or plastic film layers can be employed.

In a further embodiment of the inventive concept, it is proposed to secure the folded, Z-shaped configuration of the fastening element releasably to itself. This can be achieved, for example, by securing the folded, Z-shaped configuration with a plurality of 1 to 10, preferably 3 to 5 discrete attachment points, such as weld spots, with a cross-sectional area of less than 1mm^2 , so that the folded, Z-shaped configuration is prevented from unfolding during the manufacturing or packaging process or before the hygiene article is unfolded as intended when it is applied.

It was ascertained in a further development of this inventive concept that the folded, Z-shaped configuration can also be secured to itself when longitudinal

sections forming a particular fastening element are severed from a continuous web in the transverse direction; fibers from the layers folded over on each other in a Z-shape are worked or pulled into the layer disposed thereunder at the cut edge thus created. So when these longitudinal sections are severed, a type of needling effect in fibrous nonwovens can be achieved, which is sufficient to hold the folded, Z-shaped configuration to itself. When the longitudinal sections are severed, particularly if a "crush cut" is made, fibers from one layer are pulled into the layer disposed thereunder in the direction of the cut. This "crush cut" is preferably performed by a compliant knife, specifically a knife under pre-tension, or at least mounted to yield a small amount. This knife is preferably disposed on a rotating cylinder and when performing the cut, can be positioned under suitable pressure against a counter cylinder over which the web is guided and which forms an anvil for the knife.

In accordance with a further inventive concept of intrinsically independent significance, a recess in the material is provided in a longitudinal end zone of the rear part on both sides in the transverse outboard direction, such that the extension of the rear part in the longitudinal direction at the particular longitudinal side edge of the diaper is less than in the area between the recesses and such that the closures and their mating elements are so disposed relative to the rear part and the front part that when the diaper is applied, the back part extends farther upward than the front part, so the rear part reaches up higher than the front part. Expressed differently, this means that the securing means in the back part and the contact zone in the front part of the diaper are at different distances from the corresponding longitudinal end of the diaper in the back part or front part, respectively: the securing means are farther in the longitudinal direction from the longitudinal end of the rear part of the diaper than the

contact zone is from the longitudinal end of the front part.

This creates the impression of a slim product which is configured narrow and long. In fact, a greater longitudinal extension of the diaper can be achieved thereby, for example, if the extension of the back part in the longitudinal direction is advantageously greater than the extension of the front part.

The aforementioned recesses are preferably formed by forming blanks in the diaper or as cut-outs from a laminate comprising the top sheet and the back sheet.

In a further embodiment of the inventive concept, an edge of the back part bounding the particular recesses is located at the same height as a transverse edge bounding the front part, as said first edge transitions to a longitudinal side edge of the diaper.

Observing this embodiment of the diaper when applied to the user, the transition of the edge bounding the recess to the longitudinal side edge of the diaper, meaning the corner or transition point of the diaper side area (frequently described as the ear), is essentially at the same height as the corresponding corner or transition point of the front part.

In a further embodiment of the inventive concept, it is proposed to provide the zone for the fastening elements containing the securing means and the corresponding contact zone with an essentially identical longitudinal extent, so that the user is thereby forced to position the fastening means correctly on the contact zone. A correct fit and correct application of the diaper to the user is

thereby achieved.

It furthermore proves to be visually attractive and, with respect to achieving an optimal fit, advantageous when the diaper is applied, if the edge of the back part bounding the particular recess terminates in the transverse direction so that it always merges into the transverse edge bounding the front part or terminates therein. While a section or recess running diagonally to the longitudinal and transverse direction would be conceivable to achieve the effect in accordance with the invention, the preceding embodiment proves advantageous, since a smooth merging of the edge bounding the particular recess and the transverse edge bounding the front part is achieved thereby.

In a further embodiment of the invention, a second material recess can be furnished in the front part in a longitudinal end zone on both sides in the transverse direction outboard such that the extension of the front part in the longitudinal direction at the specific longitudinal side edge is less than in the area between the recesses. The corresponding difference in the extension will preferably be much less than in the back part.

Furthermore, it proves to be especially advantageous if fastening elements are used in the back part which have adequate extension in the longitudinal direction of 4 to 10 cm, so that the tension arising when the diaper is closed is introduced uniformly into the back part of the diaper, which has a relatively large longitudinal extension.

Additional details and benefits of the invention can be found in the appended claims and the illustrative drawings and the subsequent description of a

WO 03/015675

11

PCT/EP02/06946

preferred embodiment of the invention. In the drawings:

Figure 1 shows a sectional view of a fastening element for a hygiene article in accordance with the invention;

Figure 2 shows a plan view of the fastening element from Figure 1;

Figure 3 shows a sectional view of the fastening element from Figures 1 and 2 in the folded, Z-shaped configuration;

Figure 4 shows a plan view of a hygiene article in accordance with the invention with fastening elements folded over on one side and unfolded on the other side;

Figure 5 shows a photographic rendering of the cut edge of the folded, Z-shaped fastening element observed in the epimicroscope;

Figure 6 is a schematic representation of a cutting device for severing individual folded, Z-shaped fastening elements and

Figure 7 shows a side view of the diaper in accordance with the invention when worn.

Figures 1 and 2 show a fastening element in accordance with the invention, identified overall as 2. The fastening element 2 comprises a first section 4 of a first supporting layer 6 and a second section 8 of a second supporting layer 10.

WO 03/015675

12

PCT/EP02/06946

The fastening element 2 has been severed as a longitudinal section from a continuous web, where the continuous web extends in a first longitudinal direction. The second section 8 is located in a transverse direction 14 next to the first section 4, where in the instance shown, the first section 4 and the second section 8 overlap one another so that an overlap area 16 is formed to which the two sections 4, 8 are bonded non-detachably by means of a glue 18, by weld spots or in some other fashion.

A first zone 22 which carries an adhesive coating 24 with which the fastening element can be joined to a hygiene article is furnished on a first top side 20 of the first section 4.

Securing means 27 in the form of mechanically acting closures 28, preferably in the form of a hook component of a hook-and-loop material, are furnished in a second zone 26 of the second section 8, specifically adhered by means of a glue 30. The second zone 26 is preferably furnished on the same top side 20 of the fastening element 2 as the first zone 22.

Furthermore, first and second fold lines 32, 34 are indicated in Figure 2 and can be seen in Figure 3 around which the fastening element 2 is folded in a Z-shape in longitudinal direction 12 so that the configuration 35 shown in Figure 3 is created. Advantageously, the first fold line 32 runs immediately along a longitudinal edge 36 of the adhesive coating 24 in the first zone 22. The second fold line advantageously runs immediately along the material transition between first and second section 4 or 8, along an edge 38 of the overlap area 16.

As can be seen from Figure 3, the second zone 26 of the second section 8 is spaced apart far enough from the overlap area 16 or from any other material transition area between first section 4 and second section 8 that it is located in the transverse direction 14 outside the folded, Z-shaped configuration 35 of the fastening element 2, which proves advantageous in several respects. In the instance shown, a longitudinal edge 40 of the second zone 26 facing the first section 4, and thus the mechanically acting fasteners 28, extends in the transverse direction almost to the first fold line 36 in the folded, Z-shaped configuration 25. It would also be conceivable that the second zone 26 is positioned with respect to the second section 8 in such a way that the mechanically acting closures 28, or their longitudinal edge 40, are at a distance of a few millimeters from the folded, Z-shaped configuration 35 of the fastening element.

It should be mentioned that the first section 4 is configured elastically extensible in the transverse direction 14 and that the second section 8 is configured essentially not elastically extensible in the transverse direction 14.

An adhesive coating in the first zone 24 and the securing means 27 in the second zone 26 can be applied uninterruptedly and continuously in the longitudinal direction 12 onto a correspondingly continuous web of the first supporting layer 6 and of the second layer 8. In corresponding fashion, the first and second supporting layer 6, 8 are bonded to each other without interruption by a continuous strip of glue 18 or in some other way in the longitudinal direction 12. Simultaneous production of two symmetrically, but offset in the longitudinal direction by $\pi/2$, as known from EP 0 669 121 A1 for example, is also conceivable and advantageous.

When the fastening element with its adhesive application 24 in the first zone 22 is applied to a hygiene article, the second zone 26 with its mechanically acting closures 28 is, as already mentioned, located outside the folded, Z-shaped configuration and can thus serve to affix the fastening element, or the second section 8, to a textile surface of a hygiene article. This is explained in what follows, making reference to Figure 4.

The affixing of the second section 8 to the hygiene article is intended to serve only to secure the fastening element during manufacture and packaging until the hygiene article is applied to a user, at which time at the latest this connection is broken. A user reaches with his fingers between the top side of the hygiene article and a free end zone 42 of the second section 8, which then acts as a pull tab 44.

Figure 4 shows a plan view of a diaper 50 in accordance with the invention with fastening elements 2 disposed on both sides in a back part of the diaper 50, as described in conjunction with Figures 1 to 3. On the left side in Figure 4, the fastening element 2 is shown unfolded and on the right side it is shown folded in a Z-shape. The particular fastening element 2 is affixed non-detachably with its first zone 22 and the rectangular adhesive coating 24 to an outside of a diaper, that is to a top side 54 of a fluid-impervious back sheet 56 of the diaper when used as intended. The top side 54 is formed of a textile-like nonwoven covering of a fluid-impervious film. The back sheet 56 is consequently formed of a nonwoven/plastic film laminate.

The fastening element 2 is located in the transverse direction 14 at such distance from a longitudinal edge 58 of the diaper 50 in the side flap or ear area

WO 03/015675

15

PCT/EP02/06946

of the diaper 50 that only its pull tab projects beyond the longitudinal edge 50 in the transverse direction 14. Care is taken in particular that the second area 26 in which the mechanically acting closures 28 are provided (in the Z-shaped fold of the fastening element) does not project, or projects very little, 5 mm at the most, beyond the longitudinal edge 58 in the transverse direction 14. This prevents the closures 28 from becoming caught when the side flap or ear areas are folded onto the body facing top sheet layer and related damage from occurring.

As can be seen from Figure 4 in conjunction with Figure 3, the second zone 26 with the closures 28 is located outside the folded, Z-shaped configuration 35 and thus lies against the top side 54 of the back sheet 56 of the diaper 50. The mechanically acting closures 28 form a releasably adhering connection to the textile-like top side 54 and keep the fastening element 2 in its folded, Z-shaped configuration 35. In particular, this prevents the second section 8 with the zone 26 from becoming detached from the top side 54. In this way manageability of the hygiene article is improved after the fastening elements 2 are attached and they remain in their installed position. The diaper 50 can be handled in the production machinery, in particular folded, stacked and taken for packaging.

The unfolded state of the fastening elements 2 is shown on the left in Figure 4. To obtain this, a user grasps the pull tab and with the other hand he holds a longitudinal edge area 52 of the diaper 50 and pulls the two components apart. The releasably adhering connection of the closures 28 to the textile-like top surface 54 is broken, and the fastening elements 2 assume the shape shown on the left in Figure 4 as the folded, Z-shaped configuration 35 unfolds. To apply the diaper 50 to a user, the fastening elements can now be brought to a contact

WO 03/015675

16

PCT/EP02/06946

zone 55 in the form of a loop material in the front part of the diaper 50 and attached thereto.

To further secure the fastening elements 2 in a folded, Z-shaped configuration 35, it is conceivable to provide discrete attaching points, such as weld spots 51, which releasably join together the layers of the fastening element 2 folded in a Z-shape over on each other. However, it has been shown that the folded, Z-shaped configuration 35 can be secured in a way which satisfies requirements when the longitudinal sections forming the specific fastening elements are severed from a continuous web; fibers are pulled from the layers disposed above one another in the Z-shape into the layer lying thereunder, so that a form of needling effect is achieved which secures the Z-shaped configuration 35 releasably to itself.

Figure 5 shows a schematic outline for a cutting device for severing longitudinal sections 90 from a continuous web 92 which already has the folded, Z-shaped configuration for creating the fastening elements. The cutting device comprises an anvil cylinder 94 across which the continuous web 92 is passed and a knife cylinder 96 having a knife 98 which is under pre-tension and mounted in a floating manner or is intrinsically compliant, with a cutting edge 100. To perform the cut, the knife cylinder 96 is positioned opposite the anvil cylinder 94 in such a manner that the cutting edge 100 of the knife 98 touches the surface of the anvil cylinder 94 and can retract very slightly. The continuous web 92 is thus contacted over a relatively short circumferential area by the cutting edge 100 of the knife 98. In contrast to merely shearing, when a "crush cut" is performed, fibers of the layers overlaid on each other are hereby deflected out of one layer and pulled, crushed or worked into the layer

thereunder, so that in the severed longitudinal section 90 the layers folded over on each other in a Z-shape are at least slightly connected to each other and unintentional unfolding is thereby prevented.

A division into front part 60, back part 62 and a crotch area 64 between them can further be seen from Figure 4. The crotch area 64 is intended as that area which comprises leg cut-outs 66 to form leg openings when the diaper is applied. In diapers in which no leg cut-outs are provided and whose width or extension in the transverse direction 14 does not change or changes only slightly, the crotch area is defined as that area over whose longitudinal extension the longitudinal edge sections bounding the leg openings run. Front part 60 and back part 62 then adjoin the crotch area 64 in the longitudinal direction 62, said crotch area being symmetrical with respect to a transverse center line 68.

As shown in Figure 4, a recess in the material 72, 74 is furnished in a longitudinal end zone 70 of the back part 62 outwardly on both sides in the transverse direction 14. The material recess 72, 74 is bounded by an arcuate edge 76 or 78, which first runs diagonally from the longitudinal edge 58 and then inward in essentially a transverse direction 14 and is finally turned in the longitudinal direction 12 and then, essentially in the longitudinal direction, meets essentially perpendicularly a first transverse edge 80 which bounds the back part 62. Because of the recesses 72, 74, the extension L_a in the area of the longitudinal side edge 50 is less than the longitudinal extension L_i in the area between the recesses 72, 74. This creates the impression of a slim diaper.

It proves advantageous that the extension of the fastening elements 2 in the

longitudinal direction 12 is about 50% of the longitudinal extension of the entire back part 62, so that the tension generated when the diaper is closed is transferred in a highly uniform manner into the material forming the outside of the diaper.

Figure 4 further shows that the longitudinal extension of the contact zone 55 (indicated by arrow 82) essentially matches the longitudinal extension of the closures 28 of the fastening element 2 (indicated by arrow 84). This obliges the fastening elements 2 in the contact zone 55 to be correctly positioned and thus the diaper to be correctly seated. The fit shown in Figure 7 from the side then results. It can be seen that the edge 76 bounding the recesses 72, 74 in the transition to the longitudinal side edge 50 of the back part 62 is located at the same height as a second transverse edge 86, which bounds a longitudinal end of the front part 60 of the diaper. Optimal fit of the diaper is thereby achieved. In the instance shown in Figures 4 and 7, a less pronounced recess 88 corresponding to recesses 72, 74 is furnished in the front area 60. However, this is not absolutely necessary.

What is claimed is:

1. Hygiene article, in particular diaper for incontinence, having a fluid-pervious top sheet, a fluid-impervious back sheet and an absorbent core located therebetween, and having fastening elements (2) for releasably closing the hygiene article when applied to a user, where the hygiene article has a first longitudinal direction (12) and a second transverse direction (14), where the fastening elements (2) each carry securing means (27) and the securing means (27) coact with a contact zone (55) of the hygiene article, and where the particular fastening element (2) has a first zone (22) with which it is attached to the hygiene article and a second zone (26) which is located spaced apart in the transverse direction (14) from the first zone (22) and in which the securing means is provided, where the particular fastening element is folded in a Z-shape with fold lines (32, 34) running in the longitudinal direction, characterized in that the second zone (26) containing the securing means (28) lies outside the folded, Z-shaped configuration (35).
2. Hygiene article in accordance with claim 1, wherein the particular fastening element (2) with a zone lying outside the folded, Z-shaped configuration (35) forms a releasable retentive connection with a top side (54) of the hygiene article.
3. Hygiene article in accordance with claim 1 or 2, wherein the particular securing means (27) is formed by mechanically acting closures (28).
4. Hygiene article in accordance with claim 2 or 3, wherein the releasable retentive connection is formed by the securing means (27) themselves in the second zone (26).
5. Hygiene article in accordance with any one of claims 1 to 4, wherein the fastening elements (2) are attached to a top side of the hygiene article facing away from the body.
6. Hygiene article in accordance with claim 5, wherein the top side has a textile-like surface (54) which can be formed by a non-woven plastic film laminate which comprises the fluid-impervious back sheet (56).
7. Hygiene article in accordance with any one of claims 1 to 6, wherein the folded, Z-shaped fastening elements (2) are positioned in the transverse direction (14) in such a way respective to a longitudinal edge (58) of the hygiene article that the second zone (26) carrying the

particular securing means (27) is located at least almost entirely inside the longitudinal edge (58).

8. Hygiene article in accordance with any one of claims 1 to 7, wherein a pull tab (44) to be grasped with a user's finger is provided in the transverse direction (14) outside the second zone (26) of the particular fastening element (2) and on the side of the second zone (26) facing away from the folded configuration (35).

9. Hygiene article in accordance with claim 8, wherein the pull tab of the particular fastening element (2) projects beyond a longitudinal edge (58) of the hygiene article in the transverse direction (14).

10. Hygiene article in accordance with any one of claims 1 to 9, wherein the particular fastening element (2) has a first section (4) of a first supporting layer (6) and a second section (8) of a second supporting layer (10), which is disposed next to the first section (4) in the transverse direction and connected thereto, and the first section (4) has the first zone (22) and the second section (8) has the second zone (26).

11. Hygiene article in accordance with claim 10, wherein a fold line (34) of the fastening element (2) running in the longitudinal direction (12) runs at least in sections along a material transition between first and second section (4, 8).

12. Hygiene article in accordance with claim 11, wherein the fold line (34) runs immediately along a longitudinal edge (38) of the second section (8).

13. Hygiene article in accordance with one of the claims, 10, 11, or 12, wherein the first and the second section (4, 8) of the fastening element (2) are overlapped in the transverse direction (14) and are joined in the overlap area (16).

14. Hygiene article in accordance with any one of claims 1 to 14, wherein a fold line (32) of the fastening element (2) running in the longitudinal direction (12) runs immediately along a longitudinal edge (36) of the first zone (22).

15. Hygiene article in accordance with claim 14, wherein the fold line (32) runs immediately along a longitudinal edge (36) of an adhesive coating (24) in the first zone (22).

16. Hygiene article in accordance with any one of claims 1 to 15, wherein the second supporting layer (10) of the fastening element (2) comprises an essentially inelastic material and is configured essentially not extensible in the transverse direction (14).
17. Hygiene article in accordance with any one of claims 10 to 16, wherein the first supporting layer (6) of the fastening element (2) comprises a material elastically extensible in at least the transverse direction (14) and is configured elastically extensible in this transverse direction (14).
18. Hygiene article in accordance with any one of claims 1 to 17, wherein the first zone (22) is configured adhesively.
19. Hygiene article in accordance with any one of claims 1 to 18, wherein the folded, Z-shaped configuration (35) of the fastening element (2) is secured to itself.
20. Hygiene article in accordance with claim 19, wherein the folded, Z-shaped configuration (35) is secured to itself by a plurality of 1-10, discrete attaching points (51) with a cross-sectional area each of less than 1 mm².
21. Hygiene article in accordance with claim 19, wherein the plurality is 3 to 5 discrete attaching points.
22. Hygiene article in accordance with any one of claims 19 to 21, wherein the folded, Z-shaped configuration (35) of the fastening element (2) is secured to itself by entwining, crushing or working fibers from the layers folded over on each other in a Z-shape into the layer disposed thereunder when longitudinal sections are severed from a continuous web in the transverse direction.
23. Hygiene article in accordance with one or more of the claims 8 to 22, wherein a pull tab (44) of the fastening element (2) is formed by a non-adhesive supporting layer (10).
24. Hygiene article in accordance with any one of claims 1 to 23, wherein the extension of the fastening element (2) measures 2-10 cm, specifically 5-7 cm in the longitudinal direction.
25. Hygiene article in accordance with any one of claims 1 to 24, wherein the extension of

the first section (4) of the fastening element (2) in an elastically configured area between the longitudinal edge (6) of the first zone (22) and the material transition to the second section (8) measures 0.5-4.5 cm, specifically 2-3 cm in the transverse direction (14).

26. Hygiene article in accordance with any one of claims 1 to 25, wherein the extension of the second zone (26) of the hygiene article having the securing means (27) measures 0.5-2.1 cm, specifically 1-1.5 cm in the transverse direction (14).

27. Hygiene article in accordance with any one of claims 1 to 26, wherein the extension of the pull tab (44) of the fastening element (2) measures 0.5-2.0 cm, specifically 0.7-1.2 cm in the transverse direction (14).

28. Hygiene article in accordance with any one of claims 1 to 27, wherein the extension of the specifically adhesively configured first zone (22) of the fastening element (2) in the transverse direction (14) essentially corresponds to the width of the folded, Z-shaped configuration (35).

29. Hygiene article in accordance with any one of claims 1 to 28, wherein the first zone (22) and the second zone (26) are provided on the same side (20) of a continuous web.

EP02/06946

Application number / numéro de demande: _____

Figures: 5 _____

Pages: _____

Unscannable items
received with this application
(Request original documents in File Prep. Section on the 10th floor)

Documents reçu avec cette demande ne pouvant être balayés
(Commander les documents originaux dans la section de préparation des dossiers au
10^{ème} étage)

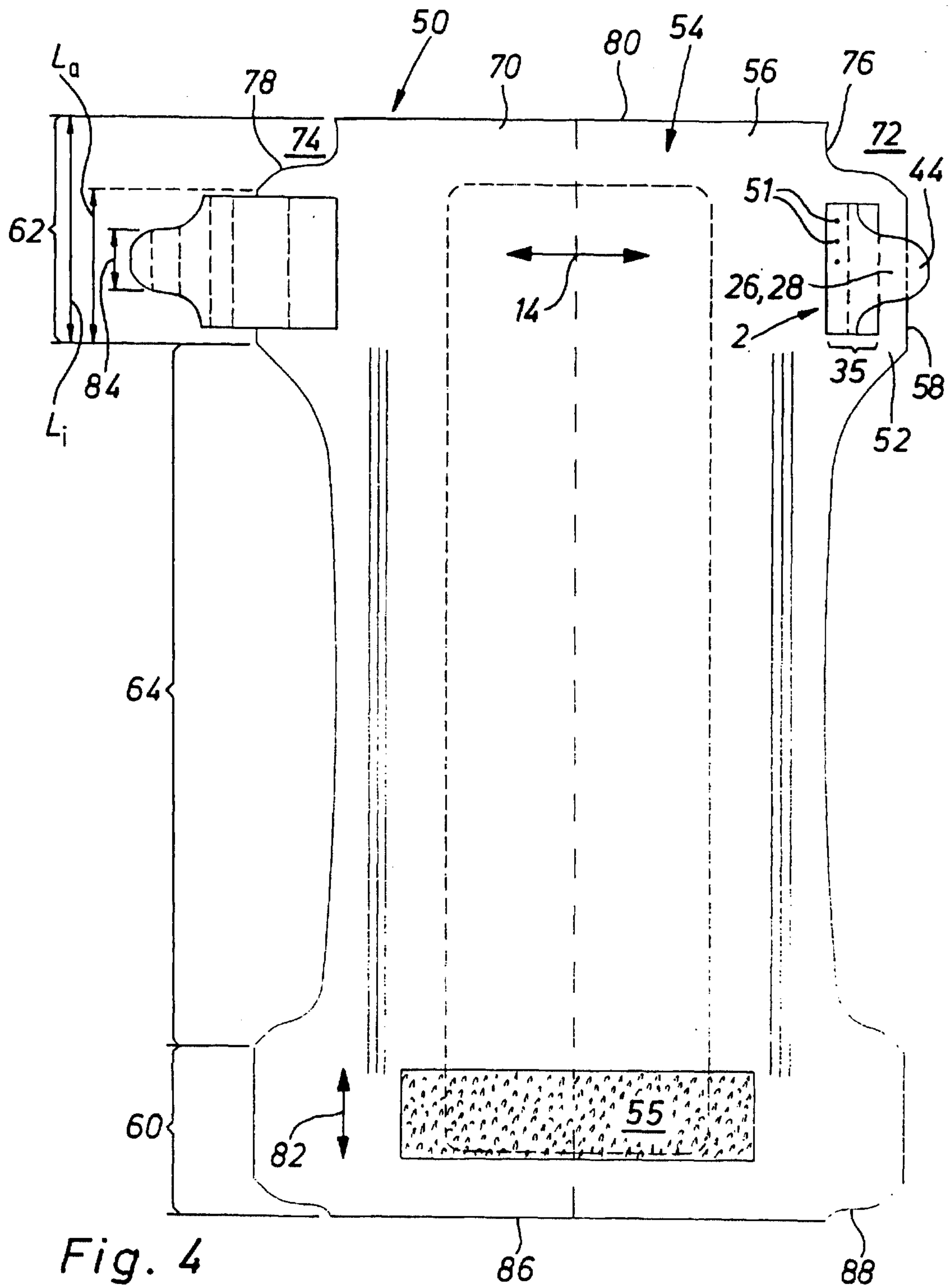

Fig. 4

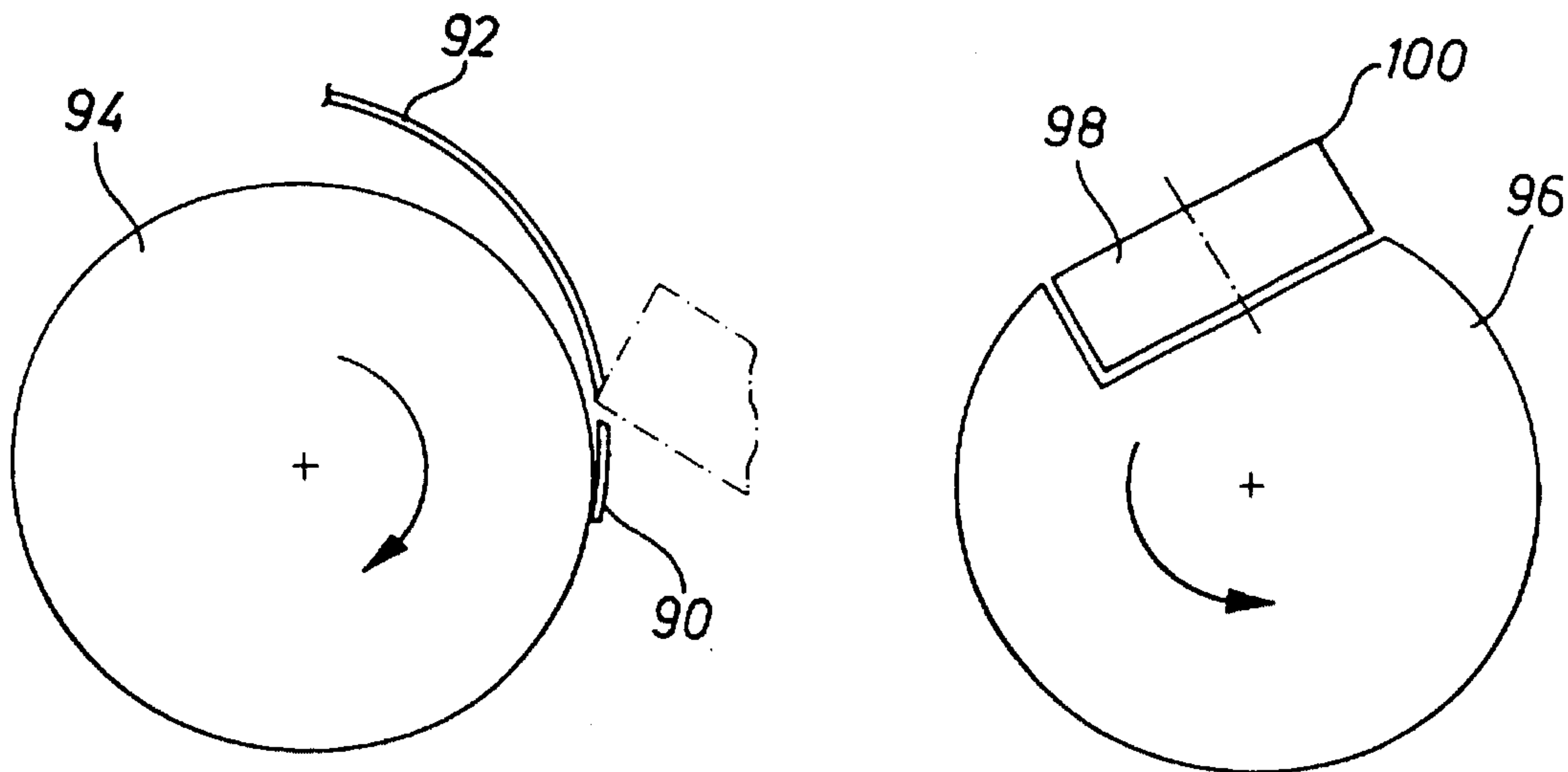

Fig. 6

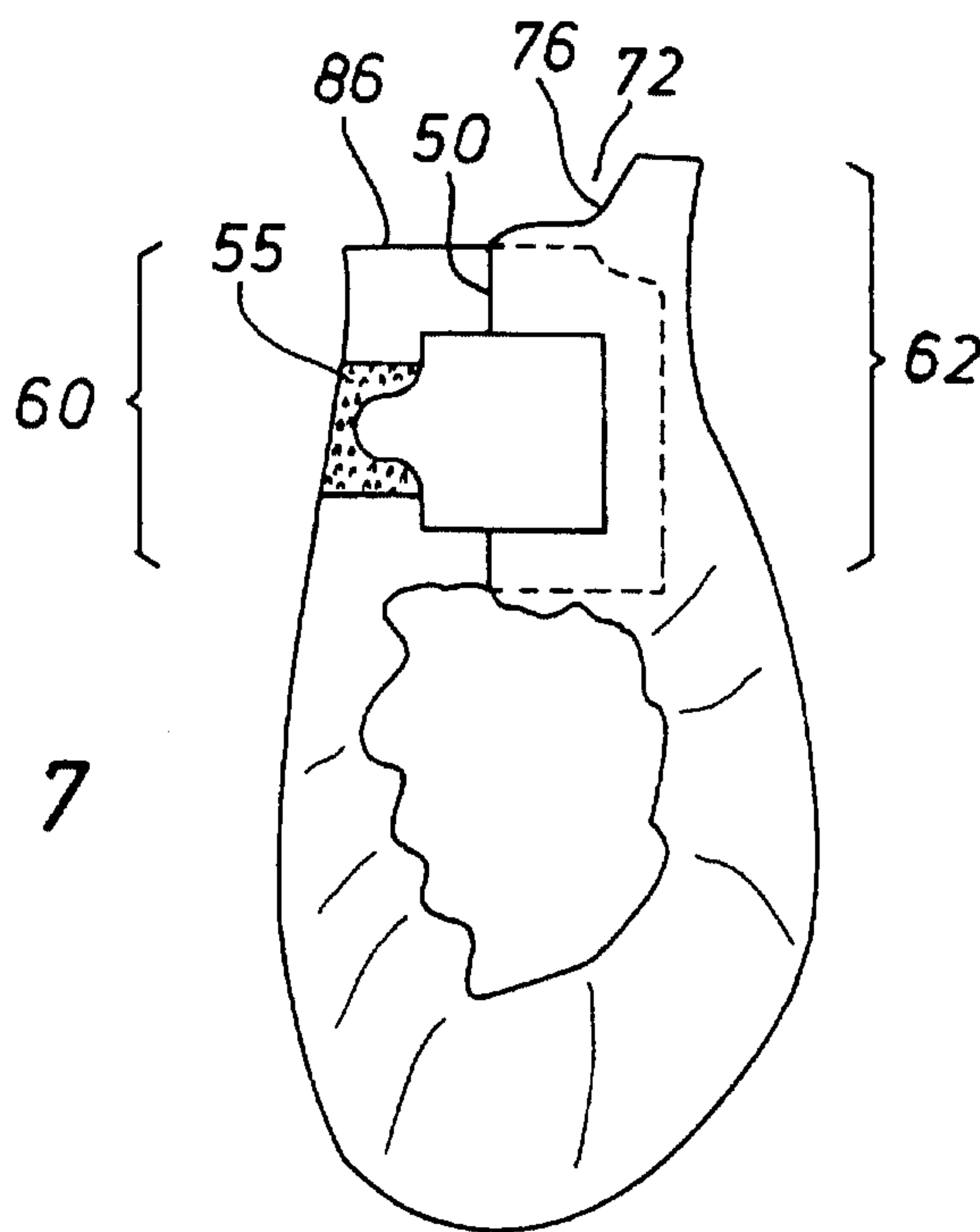

Fig. 7

