

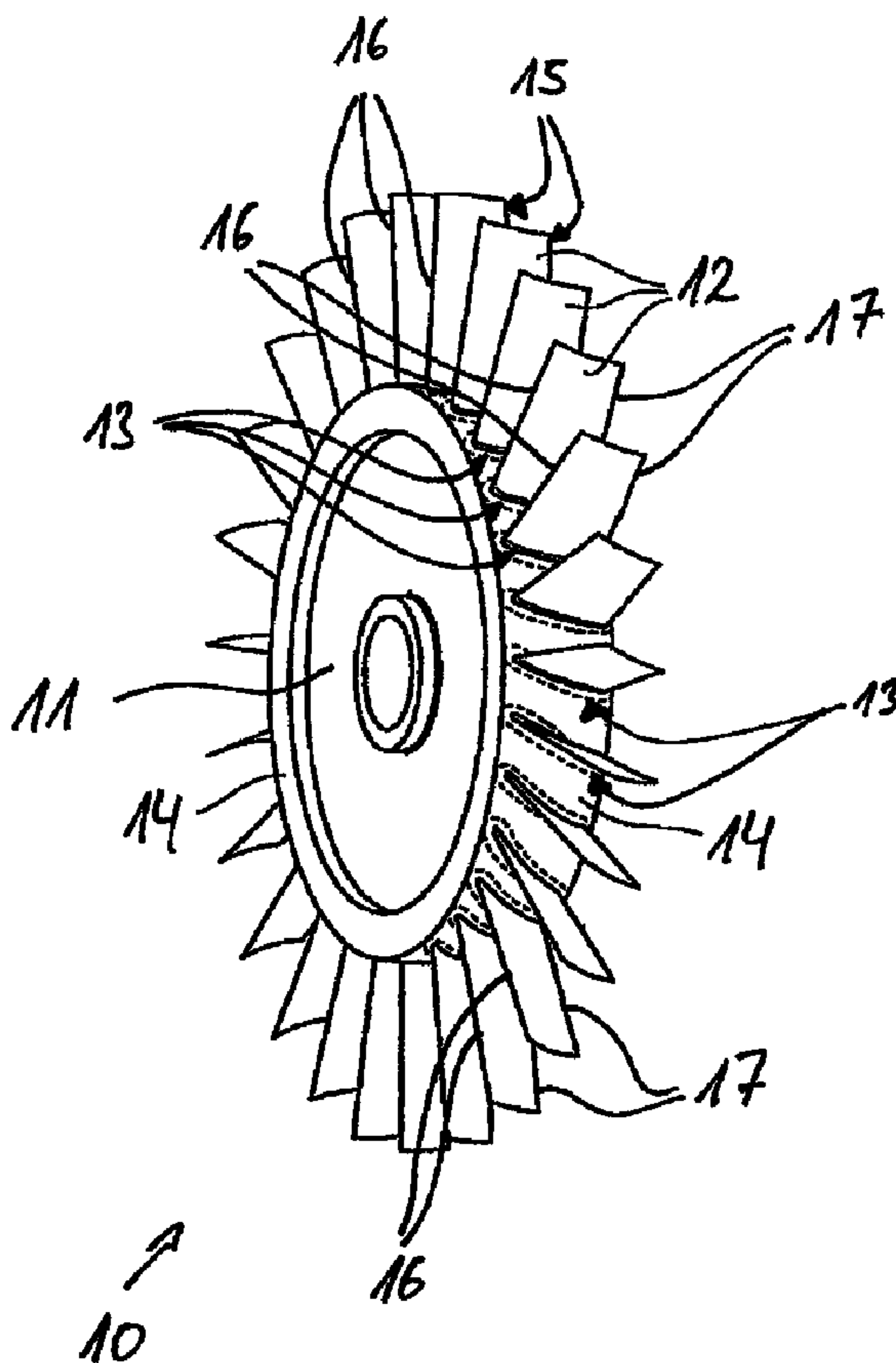

(86) Date de dépôt PCT/PCT Filing Date: 2006/02/04  
 (87) Date publication PCT/PCT Publication Date: 2006/08/17  
 (45) Date de délivrance/Issue Date: 2013/04/02  
 (85) Entrée phase nationale/National Entry: 2007/08/02  
 (86) N° demande PCT/PCT Application No.: DE 2006/000173  
 (87) N° publication PCT/PCT Publication No.: 2006/084438  
 (30) Priorité/Priority: 2005/02/12 (DE10 2005 006 414.0)

(51) Cl.Int./Int.Cl. *F01D 5/16* (2006.01),  
*F01D 5/00* (2006.01), *F01D 5/34* (2006.01),  
*F02C 7/045* (2006.01)  
 (72) Inventeur/Inventor:  
 SCHOENENBORN, HARALD, DE  
 (73) Propriétaire/Owner:  
 MTU AERO ENGINES GMBH, DE  
 (74) Agent: MARKS & CLERK

(54) Titre : PROCÉDE POUR TRAITER UN ROTOR A AUBAGE INTEGRE  
 (54) Title: METHOD FOR MACHINING AN INTEGRALLY BLADED ROTOR



(57) Abrégé/Abstract:

The invention relates to a method for machining an integrally bladed rotor of a non-positive displacement machine. According to the invention, the method comprises at least the following steps: a) providing an integrally bladed rotor (10) with a rotor base body

(57) **Abrégé(suite)/Abstract(continued):**

(11) and with a number of moving blades (12) integrally fastened to the rotor base body; b) determining the natural frequency of each moving blade (12) of the integrally bladed rotor (10); c) machining at least one moving blade (12) of the integrally bladed rotor (10) by removing material in order to set the natural frequency of the respective moving blade (12) to a specified value.

## Abstract

The invention relates to a method for machining an integrally bladed rotor of a fluid-flow machine. In accordance with the invention the method comprises at least the following steps: a) providing an integrally bladed rotor (10) having a main rotor body (11) and several rotor blades (12) integrally attached to the main rotor body; b) determining the eigenfrequency of each rotor blade (12) of the integrally bladed rotor (10); c) machining at least one rotor blade (12) of the integrally bladed rotor (10) by removing material to adjust the eigenfrequency of the particular rotor blade (12) to a specific value.

(Fig. 1)

## Method For Machining An Integrally Bladed Rotor

The invention relates to a method for machining an integrally bladed rotor of a fluid-flow engine, specifically of an integrally bladed compressor rotor for a gas turbine.

Compressor rotors of gas turbines are increasingly designed as integrally bladed rotors. Integrally bladed rotors are also designated as a blisk (bladed disk) or a bling (bladed ring), depending on whether they have a disk-shaped main rotor body or an annular main rotor body. Because of manufacturing inaccuracies in the fabrication of integrally bladed rotors, the rotor blades of the integrally bladed rotor can demonstrate an eigenfrequency deviating from a desired eigenfrequency. The result of this can be that with forced vibrations during operation, amplitudes of vibration of individual rotor blades become unacceptably large so that during operation of the fluid-flow engine, or gas turbine, the risk of damage exists.

With this as the starting point, the problem underlying the present invention is to create a method for machining an integrally bladed rotor of a fluid-flow engine.

In accordance with the invention, the method comprises at least the following steps: a) providing an integrally bladed rotor having a main rotor body and several rotor blades integrally attached to the main rotor body; b) determining the eigenfrequency of each rotor blade of the integrally bladed rotor; c) machining at least one rotor blade of the integrally bladed rotor by removing material to adjust the eigenfrequency of the particular blade to a specific value.

In the meaning of the present invention, a method is proposed with which it is possible to selectively affect the eigenfrequency of rotor blades on integrally

bladed rotors. This makes it possible to reduce the stresses acting on the rotor blades during operation and thus on the integrally bladed rotor and to substantially reduce the risk of damage to said rotor.

The particular rotor blade of the integrally bladed rotor is preferably machined by removing material in the area of a radially inward lying section and/or in the area of a radially outward lying section and/or in the area of the leading edge and/or in the area of the trailing edge.

In the case in which a rotor without an outer shroud is provided as the integrally bladed rotor, the particular rotor blade of the integrally bladed rotor is machined by removing material in the area of a radially inward lying transition section between the main rotor body and the rotor blade and/or in the area of a radially outward lying blade tip section and/or in the area of the leading edge and/or in the area of the trailing edge.

If, on the other hand, a rotor with an outer shroud is provided as the integrally bladed rotor, the particular rotor blade of the integrally bladed rotor is machined by removing material in the area of a radially inward lying transition section between main rotor body and rotor blade and/or in the area of a radially outward lying transition section between outer shroud and rotor blade and/or in the area of the leading edge and/or in the area of the trailing edge.

In accordance with a first advantageous further development of the invention, the eigenfrequency of the particular machined rotor blade is adjusted such that all rotor blades have the same eigenfrequency.

In accordance with a second advantageous further development of the invention, the eigenfrequency of the particular machined rotor blade is adjusted such that periodically changing eigenfrequencies occur around the circumference of the rotor.

Preferred further developments of the invention emerge from the dependent claims and the following description. Embodiments of the invention, without being restricted thereto, are explained in more detail using the drawing.

Fig. 1 shows an integrally bladed compressor rotor of a gas turbine in a schematic perspective side view;

Fig. 2 shows a section from the integrally bladed rotor from Fig. 1 in a schematic front view;

Fig. 3 shows a section from a blade of the integrally bladed rotor from Fig. 1 in a schematic perspective side view; and

Fig. 4 shows a schematic side view of a blade of the integrally bladed rotor from Fig. 1.

In what follows, the invention will be explained in greater detail with reference to Figs. 1 to 4.

Fig. 1 shows an integrally bladed gas turbine rotor 10 having a disk-shaped main rotor body 11 and several rotor blades 12 integrally attached to the main rotor body. Such integrally bladed gas turbine rotors having a disk-shaped main rotor body are also designated as blisks and are used preferably in the compressor of a gas turbine. The integrally bladed gas turbine rotor 10 shown in Fig. 1 is a rotor without an outer shroud. A transition area is formed between the rotor blades 12 and a hub 14 of the main rotor body 11 in a radially inward lying section 13 of the rotor blades 12. Radially outward lying sections 15 of the rotor blades 12 are designed in the case of a gas turbine rotor without an outer shroud as open rotor blade tips. Each of the rotor blades 11 possesses a leading edge 16 and a trailing edge 17, where a suction side on the one hand and a pressure side on the other extends between the leading edge 16 and the trailing edge 17 of each rotor blade 12.

The present invention relates to a method for machining an integrally bladed rotor of a fluid-flow engine, specifically the integrally bladed gas turbine rotor 10 without an outer shroud. In the meaning of the present invention, after providing such a gas turbine rotor 10, the eigenfrequency of each rotor blade 12 of the integrally bladed gas turbine rotor 10 is determined, with the determination being made either by measurement or analytically. After determining the eigenfrequency of each rotor blade 12 of the integrally bladed gas turbine rotor 10, at least one of the rotor blades 12 is machined by removing material to adjust the eigenfrequency of the particular rotor blade 12 to a specific value. The removal of material on the particular rotor blade 12 is carried out in the area of the radially inward lying section 13 and/or in the area of the radially outward lying section 15 and/or in the area of the leading edge 16 and/or in the area of the trailing edge 17 of the particular rotor blade.

In the case of the gas turbine rotor 10 without an outer shroud shown in Fig. 1, the adjustment of the eigenfrequency of the particular rotor blade 12 of the integrally bladed rotor 10 is made by removing material in the area of the radially inward lying transition section 13 between the main rotor body 11 and the particular rotor blade 12 and/or by removing material in the area of the radially outward lying blade tip section 15 and/or by removing material in the area of the leading edge 16 and/or by removing material in the area of the trailing edge 17.

If the machining of the particular rotor blade 12 is carried out by removing material in the area of the radially inward lying transition section 13 between the main rotor body 11 and the rotor blade 12, a transition radius in this transition section 13 is reduced at least in sections. The transition radii of each rotor blade 12 can vary along the circumference of the blade. Fig. 2 clarifies in schematized form the radially inward lying transition sections 13 between the main rotor body 11 and the rotor blades 12, where, by removing

material, the transition radius of each rotor blade to the main rotor body 11 can be adjusted individually as well as varyingly over the circumference of the blade.

As an alternative to, or in addition to, the removal of material in the area of the transition section 13, material removal can also be carried out in the area of the radially outward lying blade tip section 15 on the particular rotor blade 12. Fig. 3 shows a blade tip section 15 of a rotor blade 12 of the gas turbine rotor 10 without an outer shroud, where to adjust the eigenfrequency of the rotor blade 12 in accordance with Fig. 3 in the radially outward lying blade tip section 15, a squealer tip 18 is introduced. In the embodiment from Fig. 3, the squealer tip 18 is introduced into the radially outward lying blade tip section 15 in the area of a pressure side 19 so that a radially outward lying edge 21 of the rotor blade 12 has an approximately constant thickness between the leading edge 16 and the trailing edge 17. It should be pointed out that a squealer tip of this kind can also be introduced into the blade tip section 15 in the area of a suction side 20.

In combination with, or as an alternative to, the above measures for adjusting the eigenfrequency of the particular rotor blade 12, the removal of material can also be carried out in the area of the leading edge 16 and the trailing edge 17 of a rotor blade 12. Thus in Fig. 4, a total of four areas 22, 23, 24 and 25 are shown in which material can be removed in the area of the leading edge and the trailing edge 17 to adjust the eigenfrequency of a rotor blade 12. The areas 22 and 23 are introduced into the leading edge 16 or the trailing edge 17 in the area of the radially outward lying edge 21. The areas 24 and 25 are introduced into a center section of the leading edge 16 or trailing edge 17.

At this point it should be pointed out that, from the point of view of airflow, it is preferable to remove material to adjust eigenfrequencies of a rotor blade 12

in the radially inward lying transition section 13 in accordance with Fig. 2 and in the radially outward lying blade tip section 15 in accordance with Fig. 3.

If, in contrast to the embodiment shown, a rotor having an outer shroud is provided as the integrally bladed rotor, the particular rotor blade of the integrally bladed rotor is machined to adjust its eigenfrequency by removing material in the area of a radially inward lying transition section between the main rotor body and the particular rotor blade and/or in the area of a radially outward lying transition section between the outer shroud and the particular rotor blade and/or in the area of the leading edge and/or in the area of the trailing edge. Machining in the area of the radially outward lying transition section between the outer shroud and the particular rotor blade is performed in a similar way to machining in the area of the radially inward lying transition section between the main rotor body and the rotor blade, that is to say, by reducing a transition radius in these transition areas at least in sections through material removal. In this regard, reference can be made to the explanations for Fig. 2. Machining such an integrally bladed gas turbine rotor having an outer shroud in the area of the leading edge and/or the trailing edge can be performed as described in conjunction with Fig. 4 for the integrally bladed gas turbine rotor without an outer shroud.

In the meaning of the present invention, the eigenfrequency of the particular rotor blades 12 which have to be machined can be adjusted such that all rotor blades 12 of the gas turbine rotor 10 have the same eigenfrequency.

Alternatively, using the method in accordance with the invention, the eigenfrequency of the particular rotor blades 12 which have to be machined can be adjusted such that the rotor blades 12 have periodically changing eigenfrequencies around the circumference of the gas turbine rotor 10. In the first case, it is possible to speak of a selective tuning of the eigenfrequencies, and in the second case of a selective mistuning of the eigenfrequencies.

In the sense of the present invention, eigenfrequencies are determined for all rotor blades of an integrally bladed rotor. On the basis of the eigenfrequencies determined, an investigation is carried out to see whether the eigenfrequency determined for the rotor blades is deviating from a particular target eigenfrequency. If this is the case, in order to adjust the eigenfrequency of the particular rotor blade selectively, said blade is machined by removing material. The removal of the material can be carried out in different sections or areas of the rotor blades.

In conclusion, it should be pointed out that rotor blades can be machined by removing material using the method in accordance with the invention in order to adjust the eigenfrequency of said blades to a specific value.

The embodiments of the invention in which an exclusive property or privilege is claimed are defined as follows:

1. A method for machining an integrally bladed rotor of a fluid-flow machine, specifically of an integrally bladed compressor rotor of a gas turbine having the following steps:
  - a) providing an integrally bladed rotor having a main rotor body and several rotor blades integrally attached to the main rotor body;
  - b) determining the eigenfrequency of each rotor blade of the integrally bladed rotor;
  - c) machining at least one rotor blade of the integrally bladed rotor by removing material to adjust the eigenfrequency of the particular rotor blade to a specific value; wherein a transition radius in the area of a radially inward lying transition section between the main rotor body and said at least one rotor blade is reduced by removal of material.
2. A method according to claim 1, wherein the eigenfrequencies of the rotor blades of the integrally bladed rotor are determined by measurement.
3. A method according to claim 1, wherein the eigenfrequencies of the rotor blades of the integrally bladed rotor are determined analytically.
4. A method according to any one of claims 1 to 3, wherein in the machining step material removal is in the area of a radially inward lying section, in the area of a radially outward lying section, in the area of the leading edge, or in the area of the trailing edge, or any combination thereof.
5. A method according to claim 4, wherein the integrally bladed rotor does not have an outer shroud, and wherein the machining step comprises material removal:
  - in the area of a radially inward lying transition area between the main rotor body and rotor blade;
  - in the area of a radially outward lying blade tip section;

in the area of the leading edge; or  
in the area of the trailing edge;  
or any combination thereof.

6. A method according to claim 5, wherein a squealer tip is introduced in an area of a pressure side or a suction side, or both, through material removal in said area of a radially outward lying blade tip section.

7. A method according to claim 4, wherein the integrally bladed rotor has an outer shroud, and wherein the machining step comprises removal of material:  
in the area of a radially inward lying transition section between the main rotor body and rotor blade;  
in the area of a radially outward lying transition section between outer shroud and rotor blade;  
in the area of the leading edge; or  
in the area of the trailing edge;  
or any combination thereof.

8. A method according to claim 7, wherein the transition radius is reduced by removal of material in the area of a radially outward lying transition section between outer shroud and rotor blade.

9. A method according to any one of claims 1 to 8, wherein the eigenfrequency of the at least one rotor blade being machined is adjusted such that all rotor blades exhibit the same eigenfrequency.

10. A method according to any one of claims 1 to 8, wherein the eigenfrequency of the at least one rotor blade being machined is adjusted such that periodically changing eigenfrequencies occur over the circumference of the rotor.

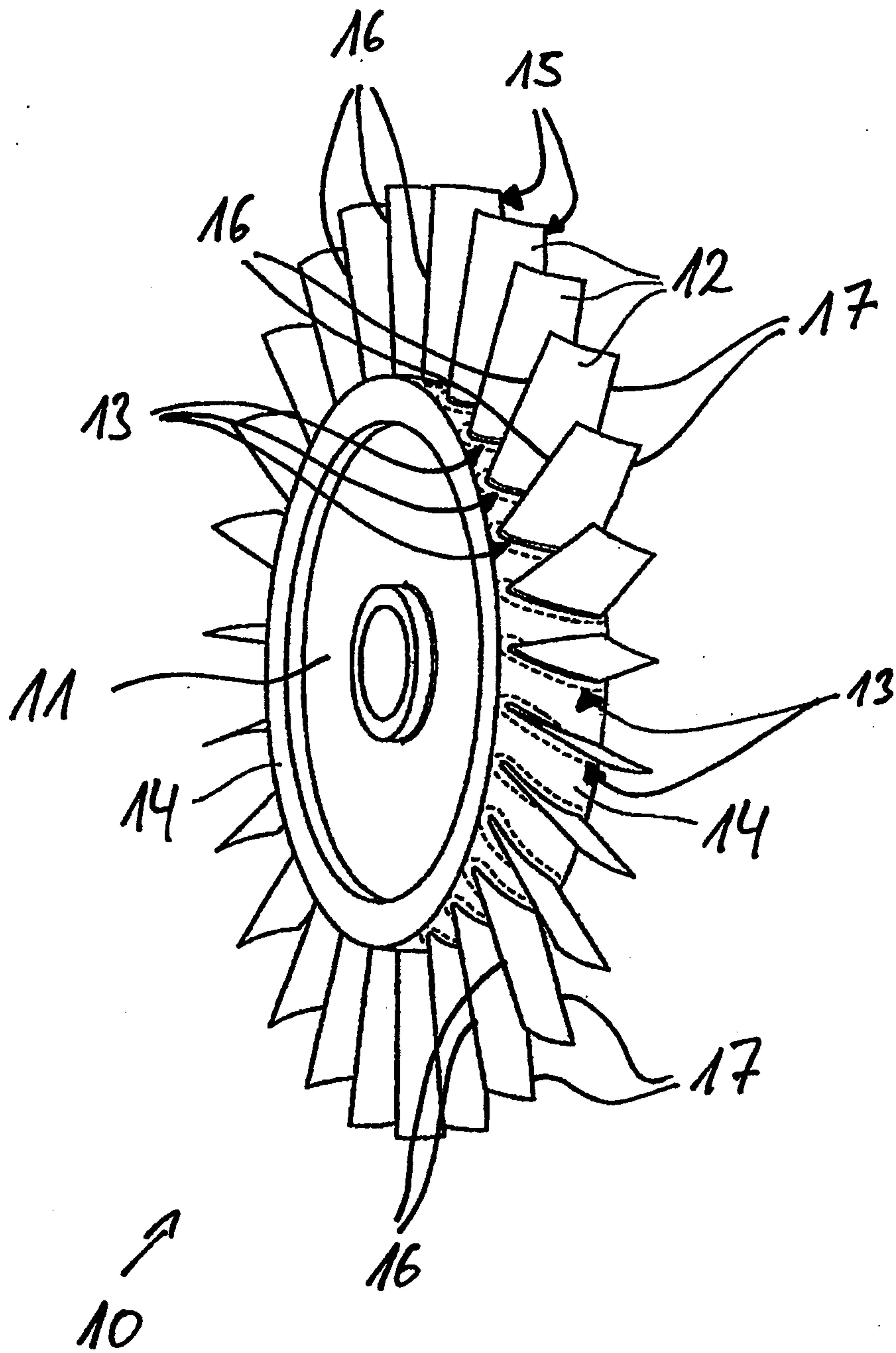

FIG. 1

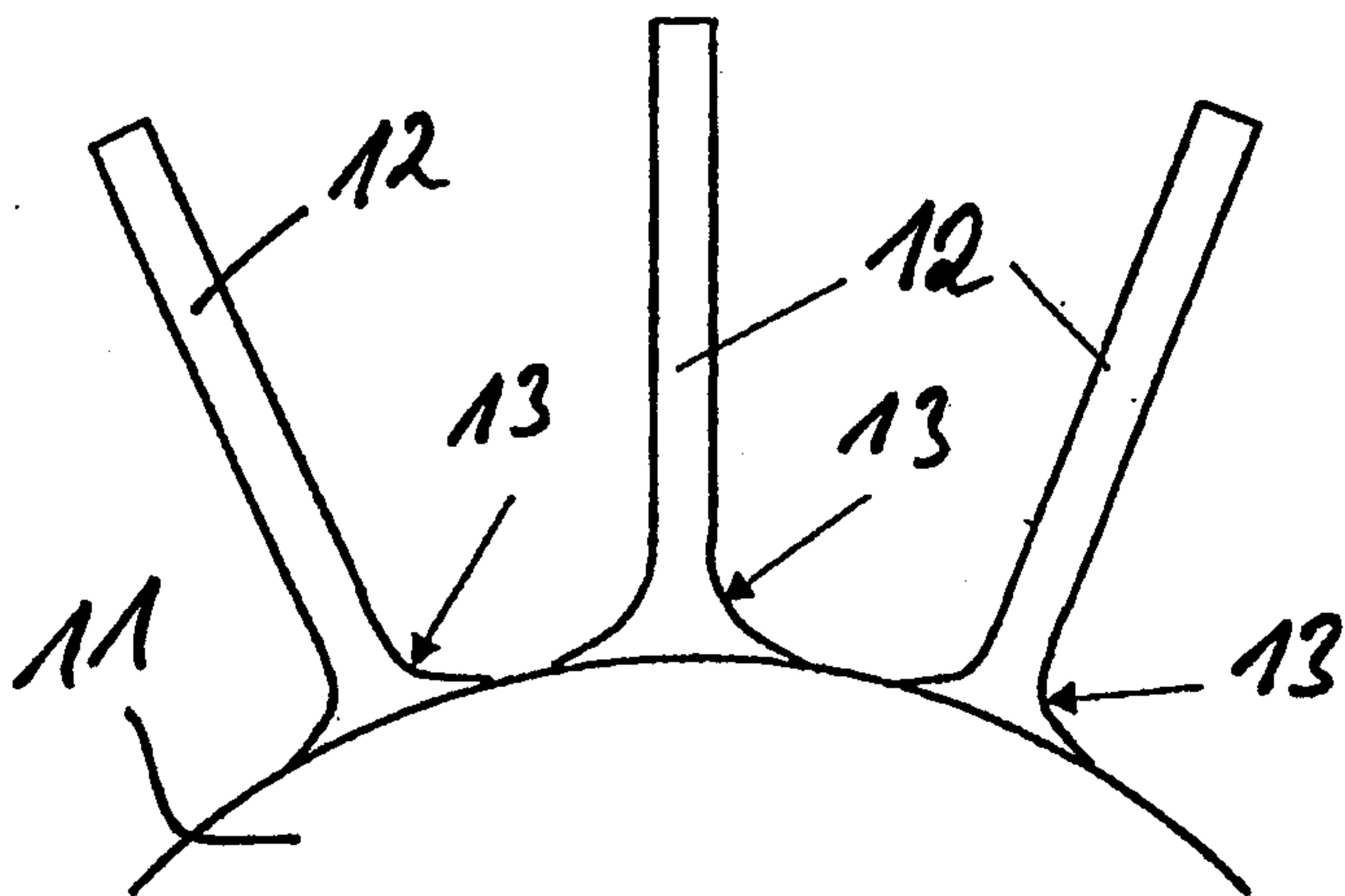

FIG. 2

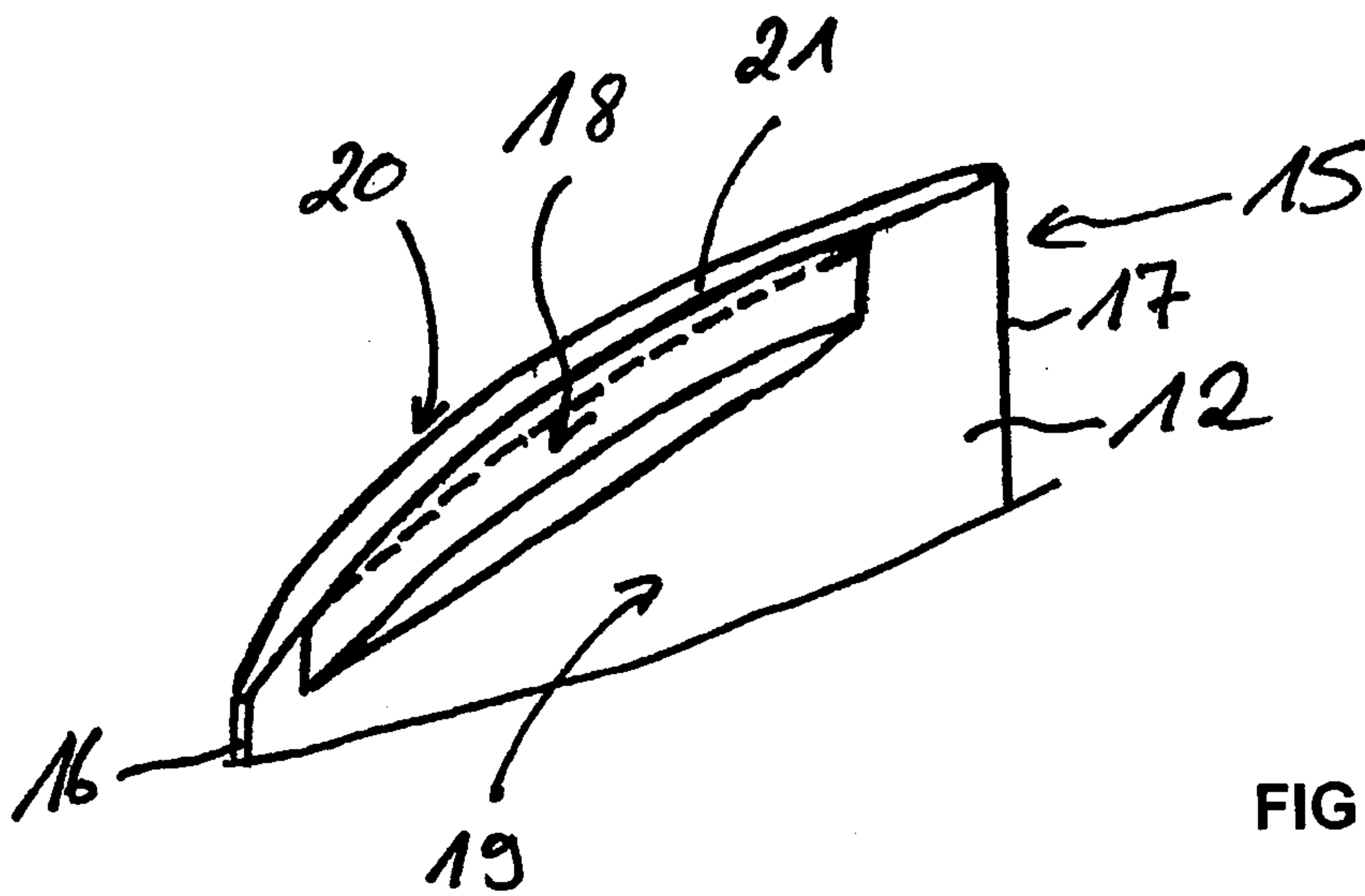

FIG. 3

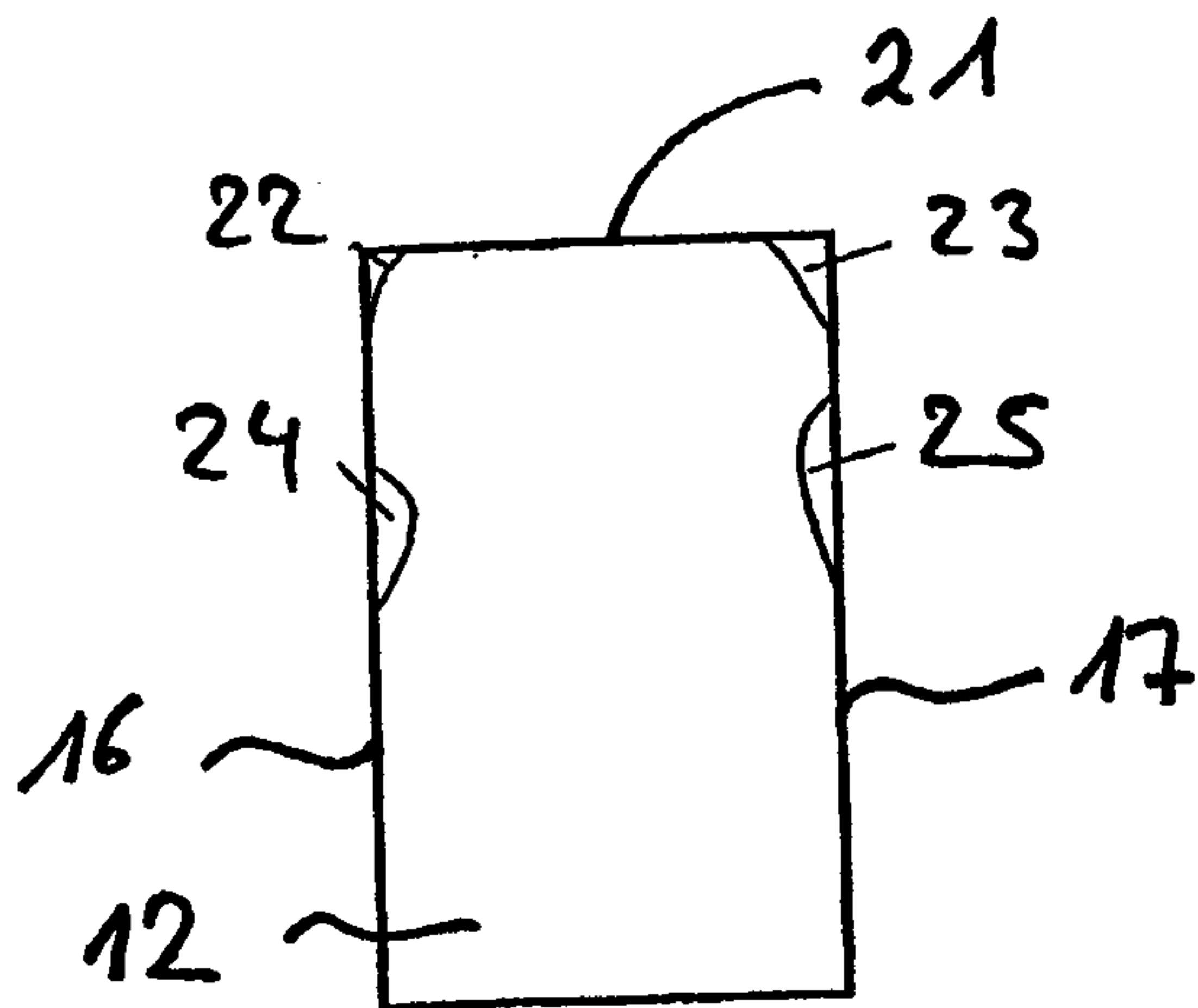

FIG. 4

