

(12) STANDARD PATENT
(19) AUSTRALIAN PATENT OFFICE

(11) Application No. **AU 2011211368 B2**

(54) Title
Vacuum cleaner comprising a motor, fan and filter arrangement

(51) International Patent Classification(s)
A47L 5/22 (2006.01) **A47L 9/22** (2006.01)
A47L 5/24 (2006.01) **A47L 9/32** (2006.01)
A47L 5/28 (2006.01)

(21) Application No: **2011211368** (22) Date of Filing: **2011.08.11**

(43) Publication Date: **2011.09.01**

(43) Publication Journal Date: **2011.09.01**

(44) Accepted Journal Date: **2012.09.13**

(62) Divisional of:
2008201597

(71) Applicant(s)
Black & Decker, Inc.

(72) Inventor(s)
Rowntree, David;Walker, Andrew

(74) Agent / Attorney
Davies Collison Cave, 1 Nicholson Street, Melbourne, VIC, 3000

(56) Related Art
US 2296359 A (E.F. Martinet) 15 May 1939

ABSTRACT

There is disclosed a vacuum cleaner (200,300) comprising a motor, fan and filter arrangement, wherein said arrangement comprises:

a motor (10);

a fan (20) connected to an output shaft (12) of said motor and having an axial intake (24); and

a filter (30, 230, 330);

wherein the fan (20) is arranged with its axial intake (24) facing said motor (10);

and

the motor (10) is housed within said filter (30, 230 330);

characterised in that:

the vacuum cleaner is a hand-holdable vacuum cleaner (200, 300) comprising a main body portion (260, 360), a handle (280, 380) and a dust collection chamber (292, 392) oriented orthogonally to the longitudinal axis of said main body portion.

The present invention concerns a motor, fan and filter arrangement for a vacuum cleaner and vacuum cleaners comprising such a motor, fan and filter arrangement. Vacuum cleaners are well known for collecting dust and dirt, although wet-and-dry variants which can also collect liquids are known as well. Typically, vacuum cleaners are intended for use in a domestic environment, although they also find uses in other environments, such as worksites. Generally, they are electrically powered and therefore comprise an electric motor and a fan connected to an output shaft of the motor, an inlet for dirty air, an outlet for clean air and a collection chamber for dust, dirt and possibly also liquids. Electrical power for the motor may be provided by a source of mains electricity, in which case the vacuum cleaner will further comprise an electrical power cable, by a removable and replaceable battery pack, or by one or more in-built rechargeable cells, in which case the vacuum cleaner will further comprise some means, such as a jack plug, for connecting the vacuum cleaner to a recharging unit. When the vacuum cleaner is provided with electrical power from one of these sources, the electric motor drives the fan to draw dirty air along an airflow pathway in through the dirty air inlet, via the collection chamber to the clean air outlet.

Interposed at some point along the airflow pathway, there is also provided some means for separating out dust and dirt (and possibly also liquids) entrained with the dirty air and depositing these in the collection chamber. This separation means may comprise one or more filters and/or a cyclonic separation device. Conventionally, in the event that the separation means comprises a filter, the motor, fan and filter have an arrangement as represented schematically in Fig. 1. As may be seen from Fig. 1, dirty air which has entered the vacuum cleaner via the dirty air inlet passes from region P to region Q through filter 30. This separates out dust and dirt (and possibly also liquids) entrained with the dirty air and the filtered material therefore remains in region P. If, as is usually the case, filter 30 is located within the collection chamber itself, the filtered material remaining in region P also accumulates there. The clean air then passes from region Q on the other side of filter 30 to a third region R through a grille 42 formed in a wall 40 on which filter 30 is mounted. Although it may be provided with an additional filter, grille 42 does not generally have

a filtering effect. Its primary purpose is instead to prevent users from gaining access to fan 20 mounted on motor output shaft 12 of motor 10, which draws air through the vacuum cleaner when motor 10 is supplied with electricity through electrical terminals 14, 16. As shown in Fig. 1, fan 20 is an impeller, which draws air in axially towards its face and expels air out tangentially, from where the air then passes to the clean air outlet of the vacuum cleaner. An example of a hand-holdable vacuum cleaner having the conventional motor, fan and filter arrangement of Fig. 1 is described in European patent publication no. EP 1 523 916 A, also in the name of the present applicant.

The conventional arrangement of motor, fan and filter described above therefore creates three separate regions, P, Q and R, of which the second region, region Q, is effectively "dead" space. In other words, whereas region P can be used to provide the collection chamber for filtered material as described, and region R houses the motor 10 and fan 20, region Q only consumes space without fulfilling any purpose. On the one hand, filter 30 should have as large a surface area as possible in order to increase its filtering effect, which tends to increase the size of region Q. This is the reason why just a flat filter located across the face of fan 20 in the location of grille 42 is generally avoided. Whereas this would dispense with region Q altogether, such a small filter would also dramatically reduce the efficiency of the vacuum cleaner by creating a bottleneck in the airflow pathway. Moreover, in order to improve the effectiveness of filter 30 still further, the filter is often also provided with a cylindrical or frusto-conical shape. Such a shape encourages dirty air in region P to swirl around filter 30 before passing therethrough, which has the effect of throwing dust and dirt particles outwardly, away from filter 30, under the action of centrifugal force in a cyclonic separation. On the other hand, however, if it is necessary to provide filter 30 with a large surface area or such a shape, the alternative solution of inserting fan 20 and possibly also part or all of motor 10 into region Q, in order to save space and reduce the size of region Q, cannot be contemplated either, since this would impede the outflow of air expelled tangentially from fan 20 towards the clean air outlet of the vacuum cleaner and instead cause the air expelled by the fan to impinge on the inner surface of filter 30, thereby countering the inflow of clean air through filter 30 and dramatically diminishing the efficiency of the filtering operation once again.

The conventional arrangement of motor, fan and filter shown in Fig. 1 is therefore inefficient in its use of space, but no obvious solution how to overcome this problem presents itself. Such an inefficient use of space is particularly undesirable in a compact or hand-holdable vacuum cleaner, where the efficient use of space is of great importance and any wasted space will necessarily add to the overall weight of the vacuum cleaner, without giving any counteracting benefit.

It would therefore be desirable to provide a motor, fan and filter arrangement for a vacuum cleaner which makes much better use of space than the conventional arrangement shown in Fig. 1. It would also be desirable to provide a motor, fan and filter arrangement particularly suitable for use in a compact or hand-holdable vacuum cleaner. It would further be desirable to provide a vacuum cleaner comprising such a motor, fan and filter arrangement.

Accordingly, the present invention provides a vacuum cleaner comprising a motor, fan and filter arrangement, wherein said arrangement comprises:

a motor;

a fan connected to an output shaft of said motor and having an axial intake; and
a filter;

wherein the fan is arranged with its axial intake facing said motor;

and

the motor is housed within said filter;

and wherein:

the vacuum cleaner is a hand-holdable vacuum cleaner comprising a main body portion, a handle and a dust collection chamber having a central axis which is oriented orthogonally to the longitudinal axis of said main body portion.

Such an arrangement allows the motor to be positioned within the filter in a reversed direction in comparison to the conventional arrangement, so that clear air from the filter is drawn over the motor before encountering the fan. The fan may thus still be located outside the filter by protruding therefrom on the output shaft of the motor, so that air expelled by the fan remains unimpeded by the filter and may still pass easily to the clean air outlet of the vacuum cleaner. Moreover, since the clean air from the filter is drawn over motor before it encounters the fan, a beneficial side-effect of cooling the motor with air from the filter is also provided, unlike in the conventional arrangement of Fig. 1, where if the motor were to be cooled with air expelled by the fan, the outflow of air from the fan

2011211368 22 Aug 2012

would have to be re-routed in order to pass over the motor. This would require the flow of air to change direction, thereby introducing aerodynamic resistance into the airflow and reducing the overall efficiency of the vacuum cleaner. In contrast, the motor, fan and filter arrangement of the preferred embodiments of the invention does not require the air expelled by the fan to be re-routed, and since the motor is contained within the filter, it makes efficient use of space and is therefore particularly suitable for use in a compact or hand-holdable vacuum cleaner.

The motor, fan and filter arrangement of the preferred embodiments of the invention also has the significant advantage that whereas the fan in the conventional arrangement of Fig. 1 is an impeller which expels air out tangentially, the fan in the motor, fan and filter arrangement of the invention can be either an impeller or a propeller, the latter of which expels air out axially from the opposite side to the face towards which air is drawn in axially by the fan. This is because in the conventional arrangement, the rear face of the fan is obstructed by the motor, so the outflow of air from the fan must be directed tangentially, whereas in the motor, fan and filter arrangement of the preferred embodiments of the invention, the rear face of the fan is unobstructed, so that air from the fan can be expelled either tangentially, as in an impeller, or axially, as in a propeller. This gives far greater versatility in overall design of the airflow within a vacuum cleaner comprising such a motor, fan and filter arrangement to direct the air expelled by the fan as desired.

The motor, fan and filter arrangement of the invention may further comprise an air-permeable housing interposed between the motor and the filter. Thus, if the filter is removable, for example in order to clean or replace it, the housing prevents a user from gaining access to the motor and fan, but air is still able to pass through the housing from the filter to the fan. Alternatively the motor housing may be impermeable to air, in which case the arrangement may further comprise a grille located between the motor and the fan, through which grille the output shaft of the motor passes. Thus, the impermeable housing completely prevents a user from gaining access to the electrical components of the motor, but air may still pass through the grille from the filter to the fan. This alternative is safer for a user than an air-permeable motor housing, but has the countervailing disadvantage that the motor is not cooled by air from the filter.

Preferably, the output shaft of the motor extends from within the filter and an end of the output shaft is mounted on a bearing located on an opposite side of the fan from the

motor. In this way, the axial intake to the fan is not blocked by either the motor or the bearing, which improves the aerodynamic efficiency of the airflow into the fan, and the extended motor output shaft is supported by the bearing, which prevents the extended shaft from vibrating under any potential imbalance in the fan as it rotates.

5 Preferably, the vacuum cleaner is a hand-holdable vacuum cleaner which is able to make greatest use of the space savings which such a motor, fan and filter arrangement provides.

Further features and advantages of the present invention will be better understood by reference to the following description, which is given by way of example and in association with the accompanying drawings, in which:

10

Fig. 1 is a cross-sectional view of a conventional motor, fan and filter arrangement for a vacuum cleaner;

Fig. 2A is an isometric view of a motor and fan suitable for use in a motor, fan and filter arrangement according to an embodiment of the invention;

15 Fig. 2B is a plan view of the motor and fan shown in Fig. 2A;

Fig. 2C is an end elevational view of the motor and fan of Fig. 2A looking in the direction of the arrow labelled "Y" in Fig. 2B;

Fig. 2D is a cross-sectional view of the motor and fan of Fig. 2A along the line A-A' represented in Fig. 2B;

20 Fig. 3 is an isometric view of a first embodiment of a vacuum cleaner comprising a motor, fan and filter arrangement according to a preferred embodiment of the invention;

Fig. 4 is close-up isometric view of a central portion of the vacuum cleaner shown in Fig. 3;

25 Fig. 5 is an exploded view of the central portion of the vacuum cleaner shown in Fig. 4;

Fig. 6 is a cross-sectional view through the central portion of the vacuum cleaner shown in Fig. 4;

30 Fig. 7 is a perspective view of a second embodiment of a vacuum cleaner comprising a motor, fan and filter arrangement according to a preferred embodiment of the invention;

Fig. 8 is a perspective view from below of the hand-holdable vacuum of Fig. 7;

Fig. 9 is a perspective view of the underside of the hand-holdable vacuum cleaner of Fig. 7;

Fig. 10 is an exploded view of the major components of the hand-holdable vacuum cleaner of Fig. 7;

Fig. 11 is a perspective view of a third embodiment of a vacuum cleaner in a motor, fan and filter arrangement according to a preferred embodiment of the invention;

Figs. 12A, 12B and 12C are perspective views of the hand-holdable vacuum cleaner of Fig. 11, respectively showing the pivotable nose thereof in 180, 360 and 135 degree positions relative to the main axis of the vacuum cleaner;

Fig. 13 is an exploded view of the major components of the hand-holdable vacuum cleaner of Fig. 11.

Firstly referring to Figs. 2A to 2D, these show a motor and fan suitable for use in a motor, fan and filter arrangement according to an embodiment of the invention. Motor 10 has an output shaft 12 on which is mounted fan 20. Electrical power is supplied to motor 10 through electrical contacts 14, 16, so that during operation of the motor, air passes over motor 10 in the direction of the arrows indicated in Fig. 2A axially into the intake or "eye" 24 of fan 20, which is an impeller and which therefore expels the air out tangentially. An end of output shaft 12 remote from motor 10 is mounted on a bearing 22 which supports output shaft 12, preventing it from vibrating under any potential imbalance in fan 20 as it rotates. As may best be seen in the plan view of Fig. 28, motor output shaft 12 has a length sufficiently great to allow the free flow of air around motor 10 into intake 24 unimpeded, and as may further be seen in the end-on view of Fig. 2C, axial intake 24 of fan 20 has a diameter greater than motor 10, so that a circumferential portion of intake 24 presents itself completely unobstructed by motor 10. Fig. 2B also indicates by means of the arrow labelled "X" the usual length of a motor output shaft found in a conventional motor and fan arrangement suitable for use in a vacuum cleaner. In such a conventional arrangement, bearing 22 is generally not required because the shorter length of the motor output shaft makes the shaft stiffer and therefore less susceptible to vibration caused by any potential imbalance in the fan as it rotates. A conventional motor may however be adapted for use in a motor, fan and filter arrangement according to the invention by the addition of an extension piece to the shorter motor output shaft thereof and/or a coupling to another shaft which carries the fan. The arrow labelled "X" in Fig. 2B also indicates the approximate location of where a grille (not shown) may be located between motor 10 and fan 20, through which grille output shaft 12 of the motor may pass, thereby screening fan 20 off from access by a user. This grille may be used to supply additional support for the motor output shaft.

Turning next to Fig. 3, there is shown a first embodiment of a vacuum cleaner comprising a motor, fan and filter arrangement according to a preferred embodiment of the invention. This is a compact stick-shaped vacuum cleaner (or "stick-vac") previously

described in more detail in co-pending European patent application no. EP 07102186.9, from which the present application claims priority. Vacuum cleaner 100 comprises an upper body portion 50, a lower body portion 60, a floorhead 70, a handle 80 and a dust-filtering portion 90. Upper body portion 50 is pivotable relative to lower body portion 60 about an axis of dust filtering portion 90. Floorhead 70 comprises a dirty air inlet and a pair of floor-running wheels 71, 72, whereas handle 80 comprises an electrical on/off switch 81. Dust filtering portion 90 comprises a tangential entry duct 91, a dust collection chamber, a clean air outlet, and a motor, fan and filter arrangement according to a preferred embodiment of the invention, which is described in greater detail below in relation to Figs. 4 to 6. During operation of vacuum cleaner 100, a user activates the motor contained in dust filtering portion 90 by operating electrical on/off switch 81, which is connected to the motor via electrical wires running inside upper body portion 50. This causes dirty air to pass from the dirty air inlet of floorhead 70 up a duct located within lower body portion 60 to tangential entry duct 91, whence it enters the dust collection chamber of dust filtering portion 90.

The dust collection chamber may best be seen in Fig. 4, where it is labelled by reference numeral 92. Dirty air entering dust collection chamber 92 via tangential entry duct 91 swirls around a cylindrical coarse filter 93 in a clockwise fashion as indicated by the arrows in Fig. 4. Coarse filter 93 surrounds and contains a smaller cylindrical fine filter 30, so that between them, coarse filter 93 and fine filter 30 act to filter out successively smaller particles of dust and dirt entrained with the dirty air, which therefore start to collect in dust collection chamber 92. An end face of dust collection chamber 92 comprises a door 94 mounted on a hinge 99 and closed via a series of latches 95, which are designed to engage with a corresponding lip on a rim of dust filtering portion 90. When door 94 is closed, a series of first component parts 96 of a filter cleaning mechanism provided on an end face of fine filter 30 engage with a corresponding series of second component parts 97 of the filter cleaning mechanism provided on the inside face of door 94. The engagement of these first and second component parts 96, 97 allows a user to operate the filter cleaning mechanism when the door is closed via a wheel (not visible in Fig. 4, but labelled 940 in Fig. 6) located on the outside face of door 94. A resilient seal 98 made of polyethylene, rubber or a similar elastomeric material provided around the circumference of door 94 ensures that the door closes in an airtight fashion.

Turning now to Fig. 5, there is shown an exploded view of the central portion of the vacuum cleaner of Fig. 3 indicating how fine filter 30 is contained within coarse filter

2011211368 22 Aug 2012

93. Within fine filter 30, there may also be seen a housing 18 of motor 10. Housing 18 is made air-permeable by the presence of a plurality of first vents 180 formed in an end face thereof. Thus, clean air passing through fine filter 30 may enter housing 18 via vents 180. Fig. 6 shows a cross-section through the central portion of this vacuum cleaner in greater detail. As may be seen in Fig. 6, motor output shaft 12 in this embodiment is constructed from an extension piece added to the shorter motor output shaft of a conventional motor. This drawing also shows how a plurality of second vents 181 formed in the opposite end face of housing 18 from the plurality of first vents 180 allows clean air to exit housing 18 and pass around motor output shaft 12 towards fan 20, which finally directs the clean air back to atmosphere via clean air outlet vents 900a, 900b. Thus, the entire filtering process from the entry of dirty air via tangential entry duct 91 to the exit of clean air via clean air outlets 900a, 900b, including motor 10, motor housing 18, fan 20, fine filter 30, coarse filter 93, filter cleaning mechanism 96, 97, 940 and dust collection chamber 92, is all contained within the particularly compact, substantially cylindrical body of dust filtering portion 90 of the vacuum cleaner.

Fig. 7 shows a second embodiment of a vacuum cleaner comprising a motor, fan and filter arrangement according to a preferred embodiment of the invention, which is a hand-holdable vacuum cleaner 200. As shown in Fig. 7, vacuum cleaner 200 comprises a main body portion 260, a handle 280, and a dust collection chamber 292 containing a filter assembly 230, both of which are oriented orthogonally to the longitudinal axis of main body portion 260, such that in use of the vacuum cleaner, dust collection chamber 292 and filter assembly 230 are held substantially vertically, and dust collects in the bottom of dust collection chamber 292. The view from below of Fig. 8 of hand-

holdable vacuum cleaner 200 shows how dust collection chamber 292 is emptied. Dust collection chamber 292 comprises a door 294 hinged on an end face thereof, which opens in the direction of the arrow shown in Fig. 8. Dust collection chamber 292 is transparent to allow a user to view dust swirling around filter assembly 230 during operation of the vacuum cleaner and also to see when dust collection chamber 292 is full and therefore needs emptying. The view from below of Fig. 8 also shows a dirty air inlet 270 of the vacuum cleaner 200.

Fig. 9 shows filter assembly 230 removed from within dust collection chamber 292 to reveal an air permeable motor housing 218 contained therein. Motor housing 218, which in turn contains a motor not visible in Fig. 9, has a plurality of first vents 280 formed in an end face thereof to allow clean air which has passed through filter assembly 230 to enter the motor housing. The exploded view of Fig. 10 shows the major internal components of hand-holdable vacuum cleaner 200. As shown in Fig. 10, main body portion 260 and handle 280 are composed from two half-clamshells 261, 262. This reveals how dirty air inlet 270 is placed in fluid communication with dust collection chamber 292 via a duct 273 integrally moulded into lower half-clamshell 262. Duct 273 is shaped so as to provide a tangential inlet to dust collection chamber 292. Space within lower half-clamshell 262 either side of duct 273 is used to house a plurality of rechargeable cells 264, which are electrically connected via wires 266 to a jack plug charger socket 268. This allows the bank of cells 264 to be recharged by means of a conventional removable jack plug charger 265 (which does not form part of the vacuum cleaner 200). Cells 264 are also electrically connected via wires 282 with an electrical on/off switch 281 mounted in handle 280. Electrical on/off switch 281 has a cover 284 to insulate it from a user. Cells 264 and on/off switch 281 are also in electrical connection via wires 216 with motor 10, such that when a user operates on/off switch 281, motor 10 is activated by cells 264, causing fan 20 mounted on motor output shaft 12 to begin to rotate and dirty air to start to be drawn up duct 273. Motor output shaft 12 is supported on a bearing 22 to prevent it from vibrating. Motor 10 itself is contained within a housing 218. This has a separate end cap 220 for ease of manufacture. Housing 218, 220 is in turn contained within filter assembly 230 inside dust collection chamber 292. The filter assembly 230 has a frusto-conical shape to act in concert with dust collection chamber 292 as a cyclonic separator.

Fig. 10 also shows door 294 of dust collection chamber 292, which door is mounted on a hinge 299 and sealed by a resilient seal 298 made of polyethylene, rubber or a similar elastomeric material, in order to ensure that the door 294 closes in an airtight fashion. Thus, during operation of vacuum cleaner 200, dirty air entering dust collection chamber 292 via duct 273 from dirty air inlet 270 swirls around filter assembly 230 and the clean air which passes therethrough is drawn through air-permeable motor housing 218 by fan 20, which directs the air through a plurality of holes 291 formed in an end face of the dust collection chamber opposite door 294 before it is expelled from a plurality of clean air outlet vents 290 formed in half-clamshell 261. In order to allow a user to empty dust collection chamber 292, half-clamshell 261 is also provided with a hole 263 revealing a spring-loaded release button 244 which acts against the force of a spring 246 to depress a push rod 268. This in turn pushes door 294 open about hinge 299. In order to allow a user to close door 294 again once the dust collection chamber has been emptied, door 294 is provided with a latch 250 that engages with a lip formed on the rim of dust collection chamber 292.

Finally turning to Fig. 11, there is shown a third embodiment of a vacuum cleaner comprising a motor, fan and filter arrangement according to a preferred embodiment of the invention, which is a hand-holdable vacuum cleaner 300. As shown in Fig. 11, vacuum cleaner 300 comprises a main body portion 360, a handle 380, and a dust collection chamber 392 designed to contain a filter assembly 330 therein, which is shown removed therefrom in Fig. 11. When mounted in dust collection chamber 392, both filter assembly 330 and dust collection chamber 392 are oriented orthogonally to the longitudinal axis of main body portion 360, such that in use of the vacuum cleaner, dust collection chamber 392 and filter assembly 330 are held substantially horizontally, and dust collects in the lower side of dust collection chamber 392. Dust collection chamber 392 is transparent to allow a user to view dust swirling around filter assembly 330 during operation of the vacuum cleaner and also to see when dust collection chamber 392 is full and therefore needs emptying.

Fig. 11 also shows how dust collection chamber 392 can be emptied by means of a door 394 hinged on an end face thereof. Fig. 11 also reveals an air permeable motor housing 318 contained inside filter assembly 330. Motor housing 318, which in

turn contains a motor not visible in Fig. 11, has a plurality of vents 380 formed in an end face thereof to allow clean air which has passed through filter assembly 330 to enter the motor housing.

5 Vacuum cleaner 300 is able to pivot about the central axis of dust collection chamber 392 in a manner similar to that described in European patent publication no. 1 752 076 A, also in the name of the present applicant. Thus, as shown in Figs. 12A to 12C, vacuum cleaner 300 may be folded as indicated by the arrows in Figs. 12B and 12C from the 180 degree position shown in Fig. 12A into the 360 degree position
10 shown in Fig. 12B, for example for storage or shipping, or into the 135 degree position shown in Fig. 13C, for example to permit access to awkward corners. Fig. 12 C also reveals a dirty air inlet 370 of vacuum cleaner 300.

The exploded view of Fig. 13 shows the major internal components of hand-
15 holdable vacuum cleaner 300. As shown in Fig. 13, main body portion 360 is formed from upper and lower components 361 and 362, respectively, and handle 380 is composed from two half-clamshells 385, 386. Dirty air inlet 370 is placed in fluid communication with dust collection chamber 392 via a duct 373 contained within main body portion 360 and which enters dust collection chamber 392 tangentially.
20 Space within lower body component 362 beneath duct 373 is occupied by a plurality of rechargeable cells 364, which are electrically connected via wires 366 to a jack plug charger socket 368. This allows the bank of cells 364 to be recharged by means of a conventional removable jack plug charger 365 (which does not form part of the vacuum cleaner 300). Cells 364 are also electrically connected via wires 382
25 with an electrical on/off switch 381 mounted in handle 380. Electrical on/off switch 381 has a cover 384 to insulate it from a user. Cells 364 and on/off switch 381 are also in electrical connection via wires 316 with motor 10, such that when a user operates on/off switch 381, motor 10 is activated by cells 364, causing fan 20 mounted on motor output shaft 12 to begin to rotate and dirty air to start to be drawn
30 up duct 373. Because vacuum cleaner 300 can pivot in the manner described above in relation to Figs. 12A to 12C, wires 382 connected to on/off switch 381 terminate in a pair of electrical contacts 388, which remain in sliding contact with a corresponding pair of conducting tracks 389 mounted on dust collection chamber 392. Thus, an electrical circuit can always be established between cells 364, on/off switch 381 and

motor 10, regardless of the angle of orientation of main body 360 relative to handle 380.

5 As can also be seen in Fig. 13, a bearing 22 located at the end of motor output shaft 12 remote from motor 10 supports motor output shaft 12 to prevent it from vibrating. Motor 10 itself is contained within housing 318. This has a separate end cap 320 for ease of manufacture, in which can be seen the vents 380 to allow clean air which has passed through filter assembly 330 to enter the motor housing. Housing 318, 320 is in turn contained within filter assembly 330 inside dust collection chamber 392. The filter assembly 330 has a frusto-conical shape to act in concert with dust collection chamber 392 as a cyclonic separator.

15 Fig. 13 also shows door 394 of dust collection chamber 392, which door has a spring-loaded latch 344 that can be depressed against the force of a spring 346 to open door 394. Latch 344 engages with a lip formed on the rim of dust collection chamber 392 to allow the door to be closed again. The door is sealed by a resilient seal 398 made of polyethylene, rubber or a similar elastomeric material, in order to ensure that the door 394 closes in an airtight fashion. Thus, during operation of vacuum cleaner 300, dirty air entering dust collection chamber 392 via duct 373 from dirty air inlet 370 swirls around filter assembly 330 and the clean air which passes therethrough is drawn through air-permeable motor housing 318 by fan 20, which directs the air through a plurality of holes 391 formed in an end face of the dust collection chamber opposite door 394 before it is expelled from a plurality of clean air outlet vents 390 formed in half-clamshell 385. To allow a user to adjust the angle of main body 360 relative to handle 380, half-clamshell 386 is finally also provided with a ratchet wheel 350 having a plurality of teeth formed on the inner circumference thereof. These act to lock main body 360 in one of a plurality of orientations relative to handle 380. Ratchet wheel 350 is also provided with a spring-loaded release button 352 which can be depressed against the force of a spring 354 to allow a user to disengage the teeth and therefore rotate main body 360 from one orientation into another. Releasing button 352 again relocks main body in the new orientation relative to handle 380.

Throughout this specification and the claims which follow, unless the context requires otherwise, the word "comprise", and variations such as "comprises" or "comprising", will be understood to imply the inclusion of a stated integer or step or group of integers or steps but not the exclusion of any other integer or step or group of integers or steps.

- 5 The reference in this specification to any prior publication (or information derived from it), or to any matter which is known, is not, and should not be taken as an acknowledgment or admission or any form of suggestion that that prior publication (or information derived from it) or known matter forms part of the common general knowledge in the field of endeavour to which this specification relates.

THE CLAIMS DEFINING THE INVENTION ARE AS FOLLOWS:

- 5 1. A vacuum cleaner comprising a motor, fan and filter arrangement, wherein said arrangement comprises:
- a motor;
 - a fan connected to an output shaft of said motor and having an axial intake; and
 - a filter;
- 10 wherein the fan is arranged with its axial intake facing said motor;
- and
- the motor is housed within said filter;
- and wherein:
- the vacuum cleaner is a hand-holdable vacuum cleaner comprising a main body
- 15 portion, a handle and a dust collection chamber having a central axis which is oriented orthogonally to the longitudinal axis of said main body portion.
2. A vacuum cleaner comprising a motor, fan and filter arrangement according to claim 1, wherein the fan is an impeller having a tangential output.
- 20 3. A vacuum cleaner comprising a motor, fan and filter arrangement according to claim 1, wherein the fan is a propeller having an axial output from a face opposite to its axial intake.
- 25 4. A vacuum cleaner comprising a motor, fan and filter arrangement according to any one of the preceding claims, further comprising an air-permeable housing interposed between said motor and said filter.
- 30 5. A vacuum cleaner comprising a motor, fan and filter arrangement according to any one of the preceding claims, further comprising a grille located between the motor and the fan, through which grille the output shaft of the motor passes.

6. A vacuum cleaner comprising a motor, fan and filter arrangement according to any one of the preceding claims, wherein the output shaft of the motor extends from within said filter and an end of said output shaft is mounted on a bearing located on an opposite side of said fan from said motor.

5

7. A vacuum cleaner comprising a motor, fan and filter arrangement according to any one of the preceding claims, wherein the axial intake of said fan has a diameter greater than that of said motor.

10 8. A vacuum cleaner comprising a motor, fan and filter arrangement according to any one of the preceding claims, wherein the filter has a cylindrical or frusto-conical shape and is mounted concentrically within a cylindrical dust collection chamber having a tangential inlet duct.

15 9. A vacuum cleaner according to any one of the preceding claims, wherein the dust collection chamber is oriented orthogonally to the longitudinal axis of said main body portion such that in use of the vacuum cleaner pen, said dust collection chamber is held substantially vertically to cause dust to collect in the bottom of said dust collection chamber, and said dust collection chamber comprises a door hinged on an end face
20 thereof beneath said bottom.

10. A vacuum cleaner according to claim 9, further comprising a user-operable resilient release button acting on a push rod to push said door open.

25 11. A vacuum cleaner according to any one of the preceding claims, wherein the dust collection chamber is oriented orthogonally to the longitudinal axis of said main body portion such that in use of the vacuum cleaner, said dust collection chamber is held substantially horizontally and wherein said main body portion is pivotable relative to said handle about an axis of said dust collection chamber.

30

2011211368 22 Aug 2012

12. A vacuum cleaner according to claim 11, wherein said handle comprises a user-operable on/off switch electrically connected to a pair of contacts in sliding contact with a respective pair of electrically conducting tracks mounted on said dust collection chamber.

5

13. A vacuum cleaner according to claim 11 or claim 12, wherein the main body portion is lockable in one of a plurality of different orientations relative to said handle.

14. A vacuum cleaner according to claim 13, further comprising a ratchet wheel having a plurality of teeth formed on an inner circumference thereof and a resilient release button for disengaging said ratchet wheel.

10

15. A vacuum cleaner according to any one of the preceding claims, wherein the dust collection chamber is transparent.

15

16. A vacuum cleaner comprising a motor, fan and filter arrangement, substantially as hereinbefore described with reference to the drawings and/or Examples.

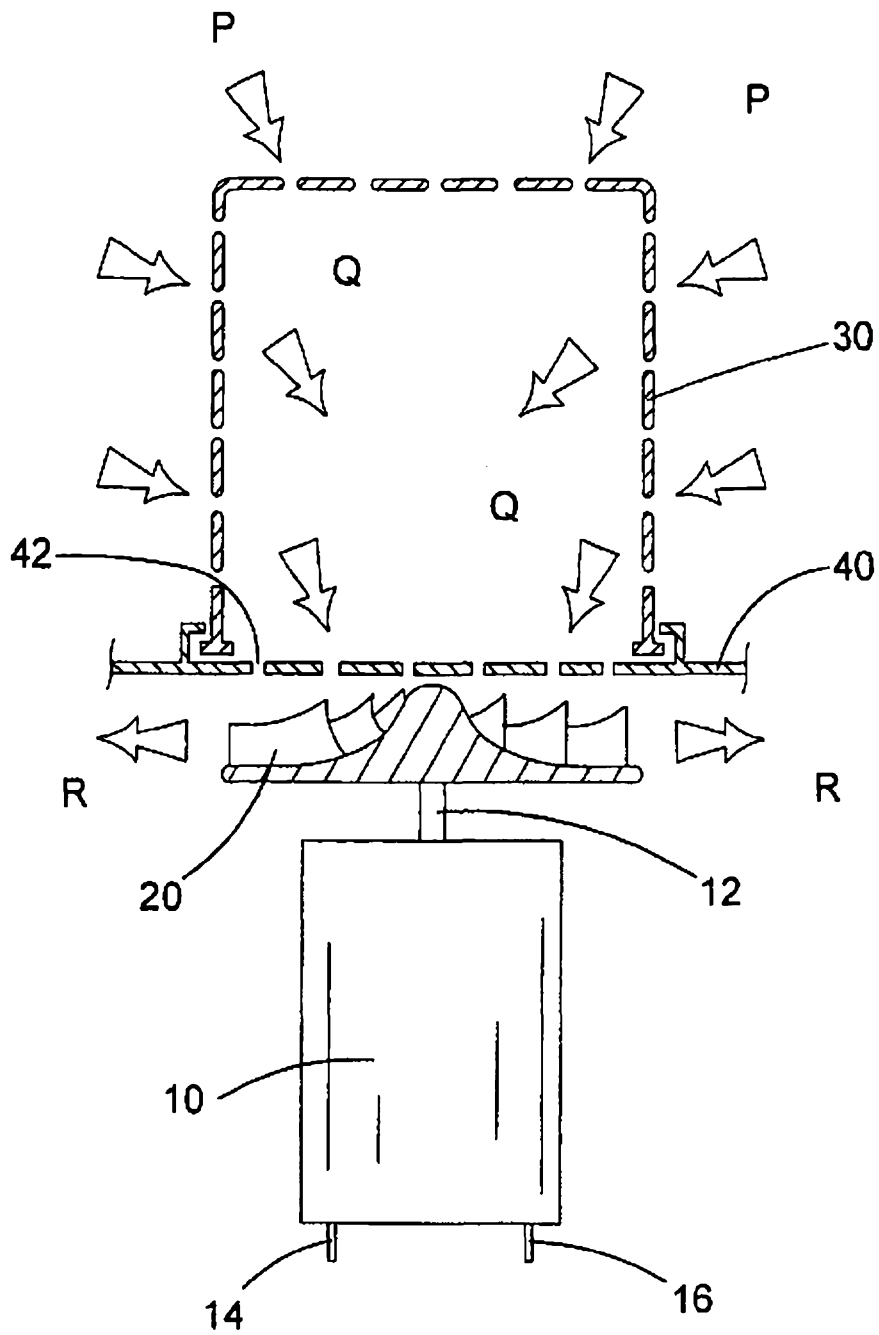

FIG.1
(PRIOR ART)

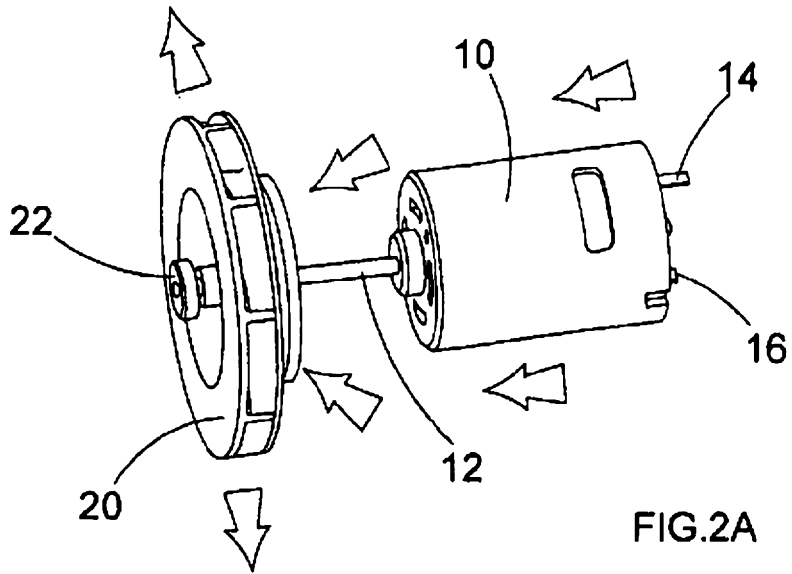

FIG.2A

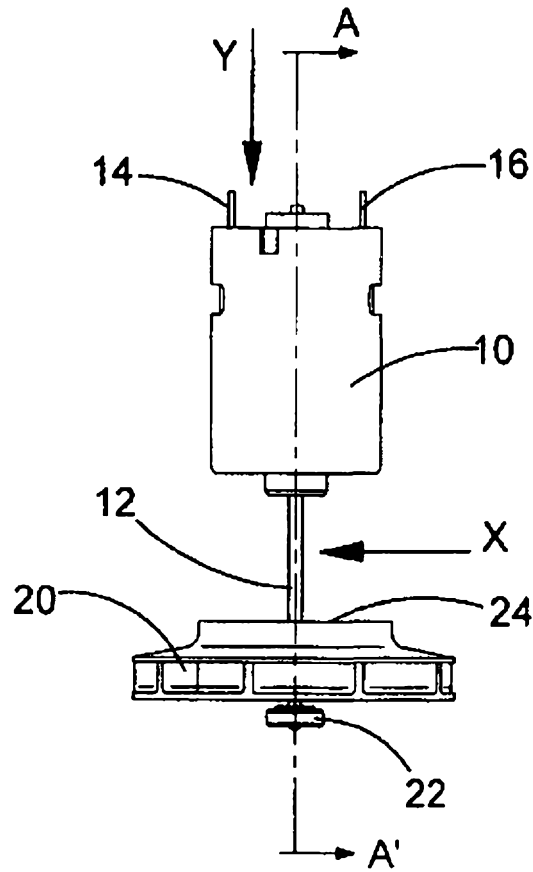

FIG.2B

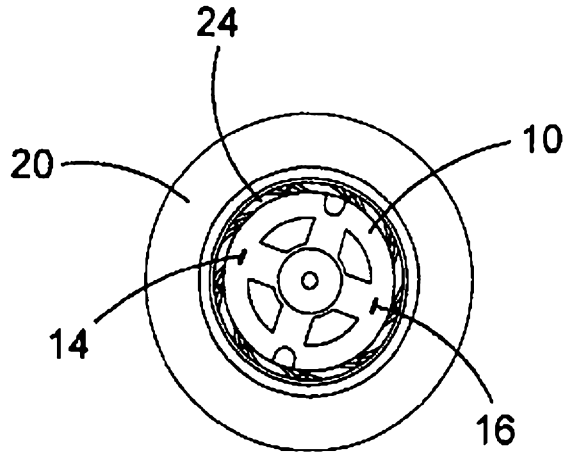

FIG. 2C

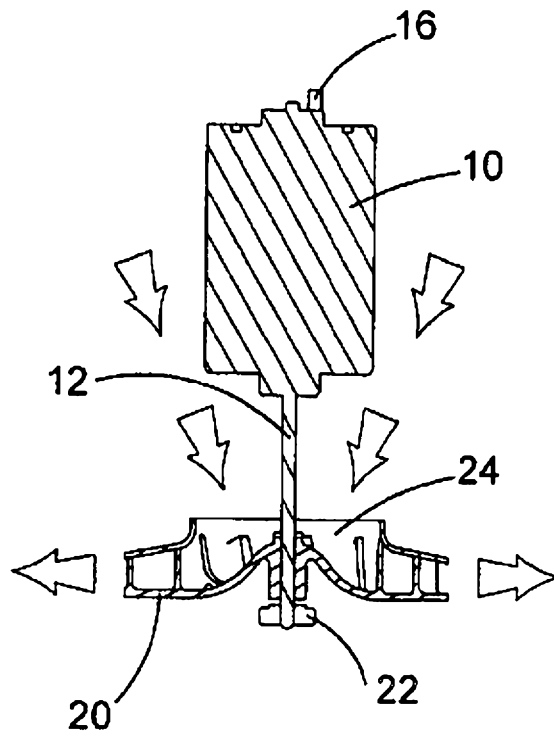

FIG. 2D

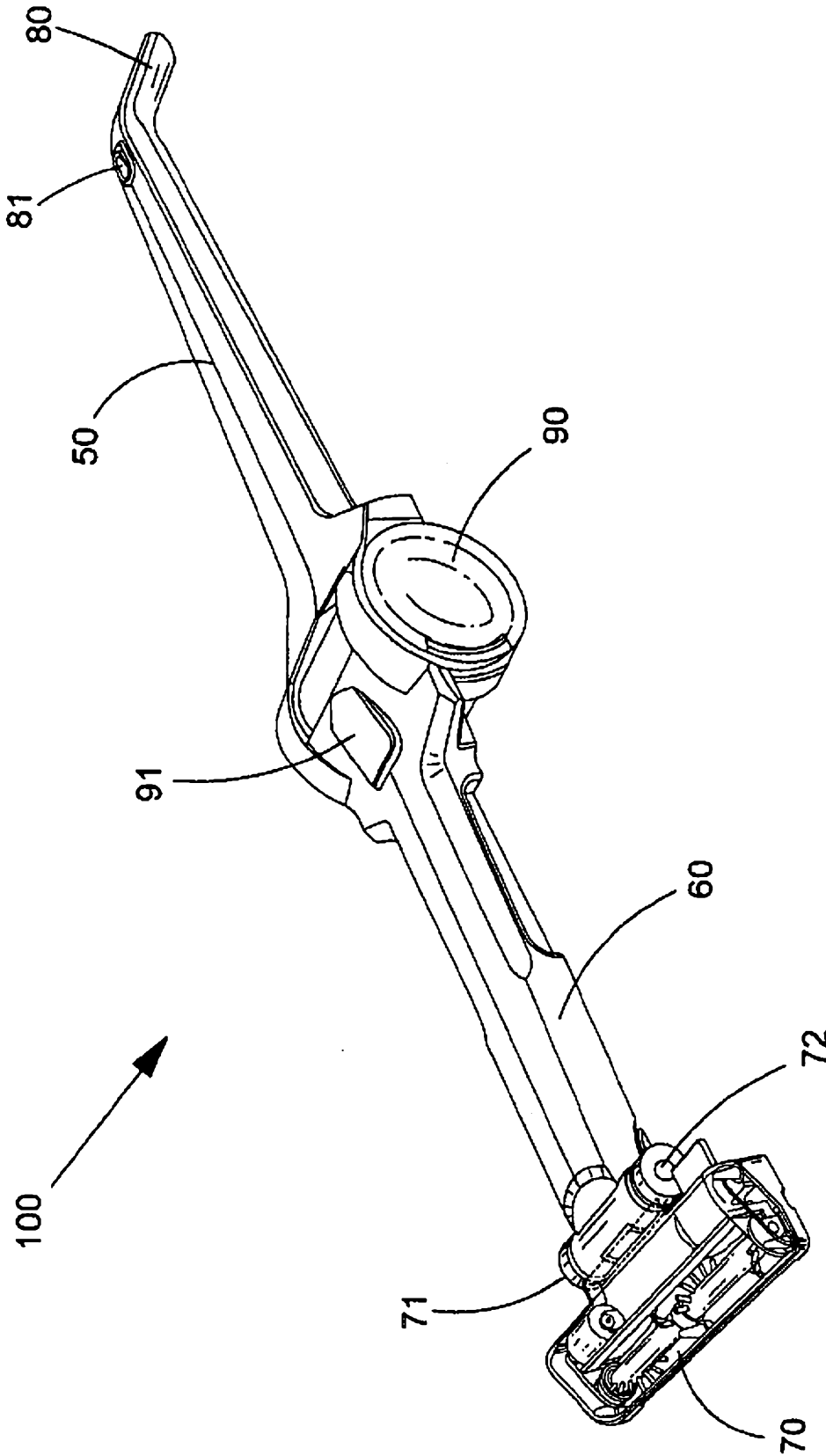

FIG.3

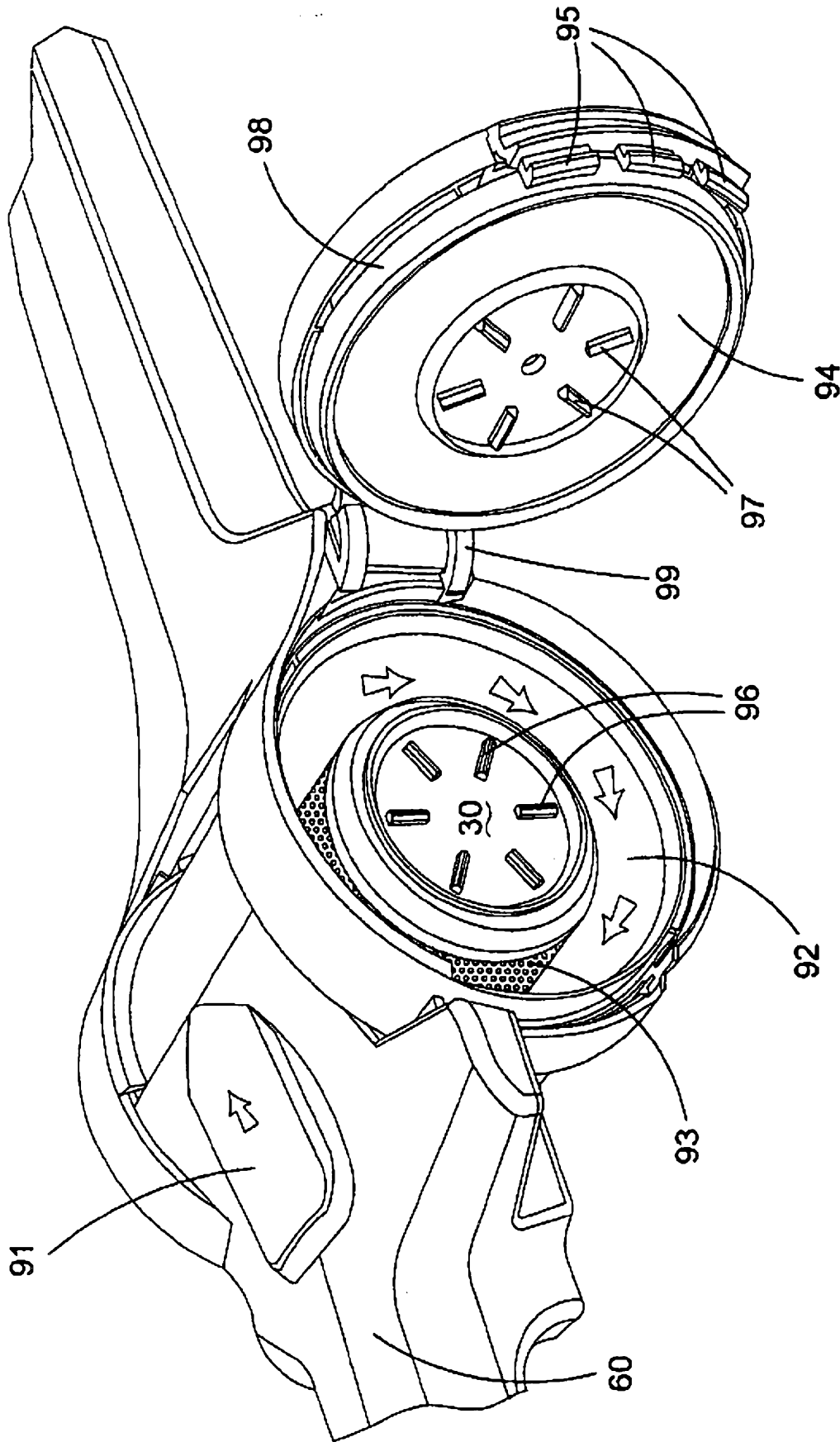

FIG.4

2011211368

11 Aug 2011

6/13

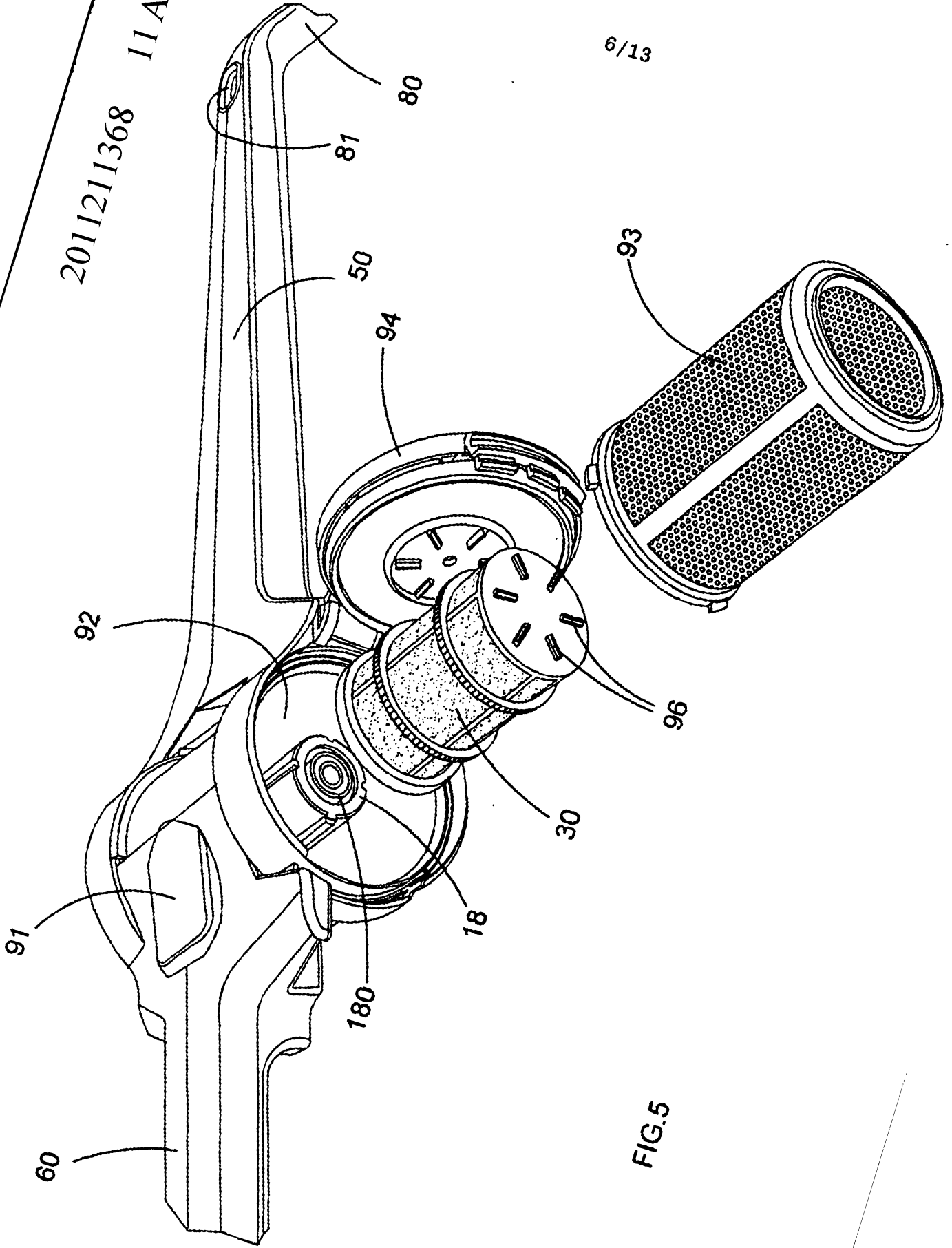

FIG.5

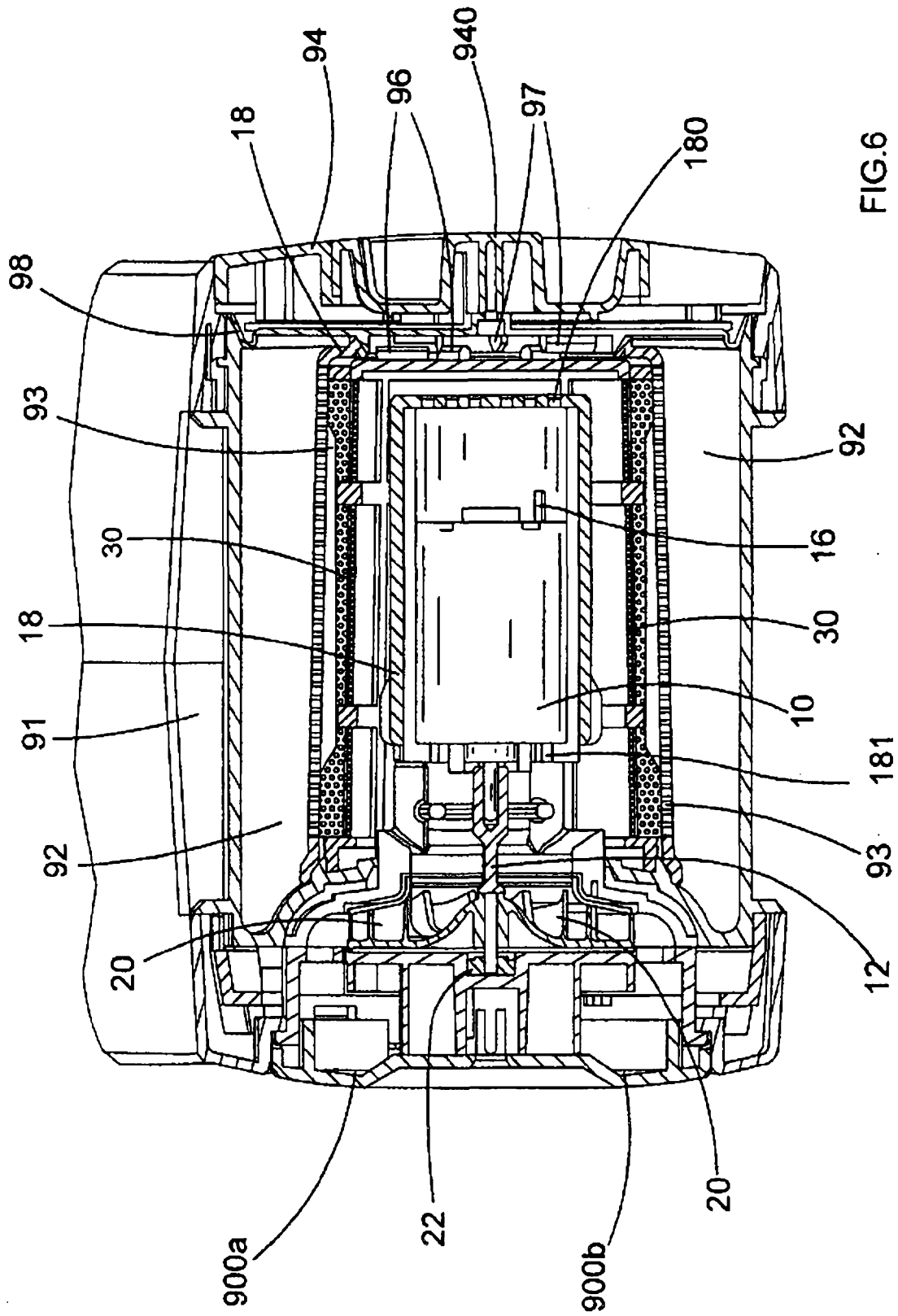

FIG.6

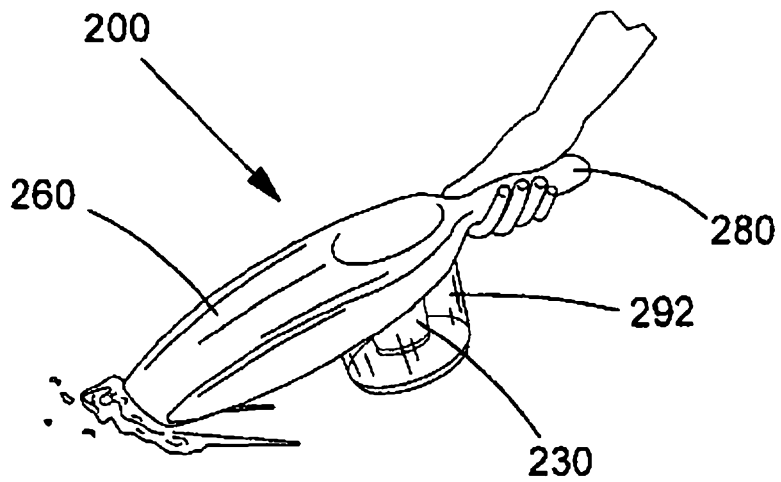

FIG. 7

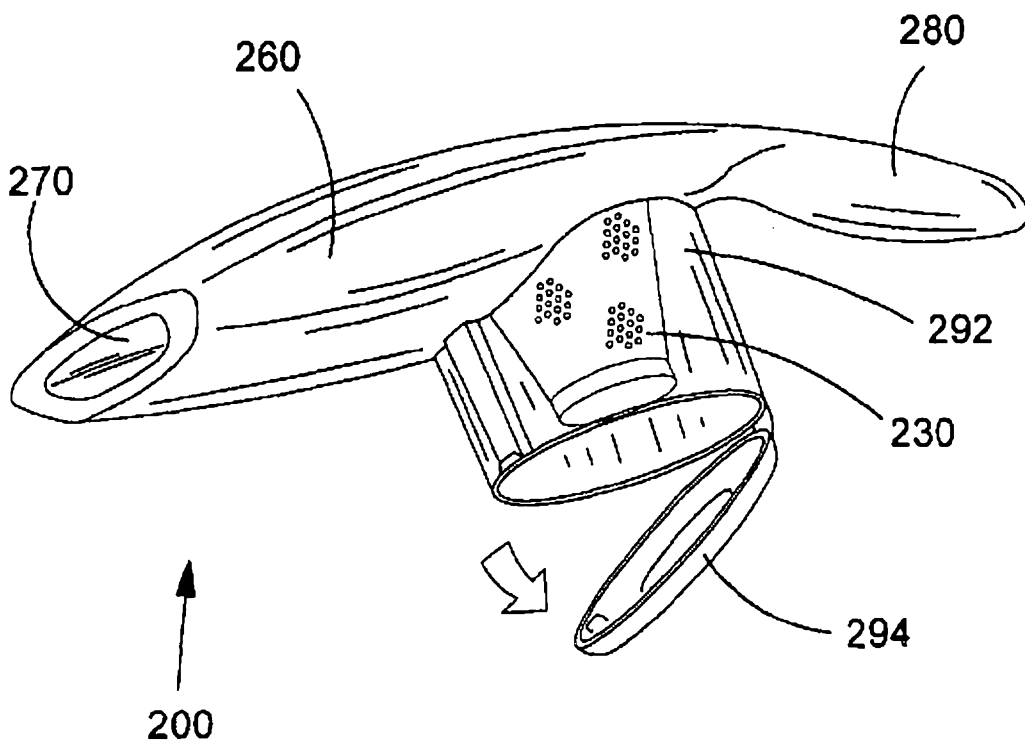

FIG. 8

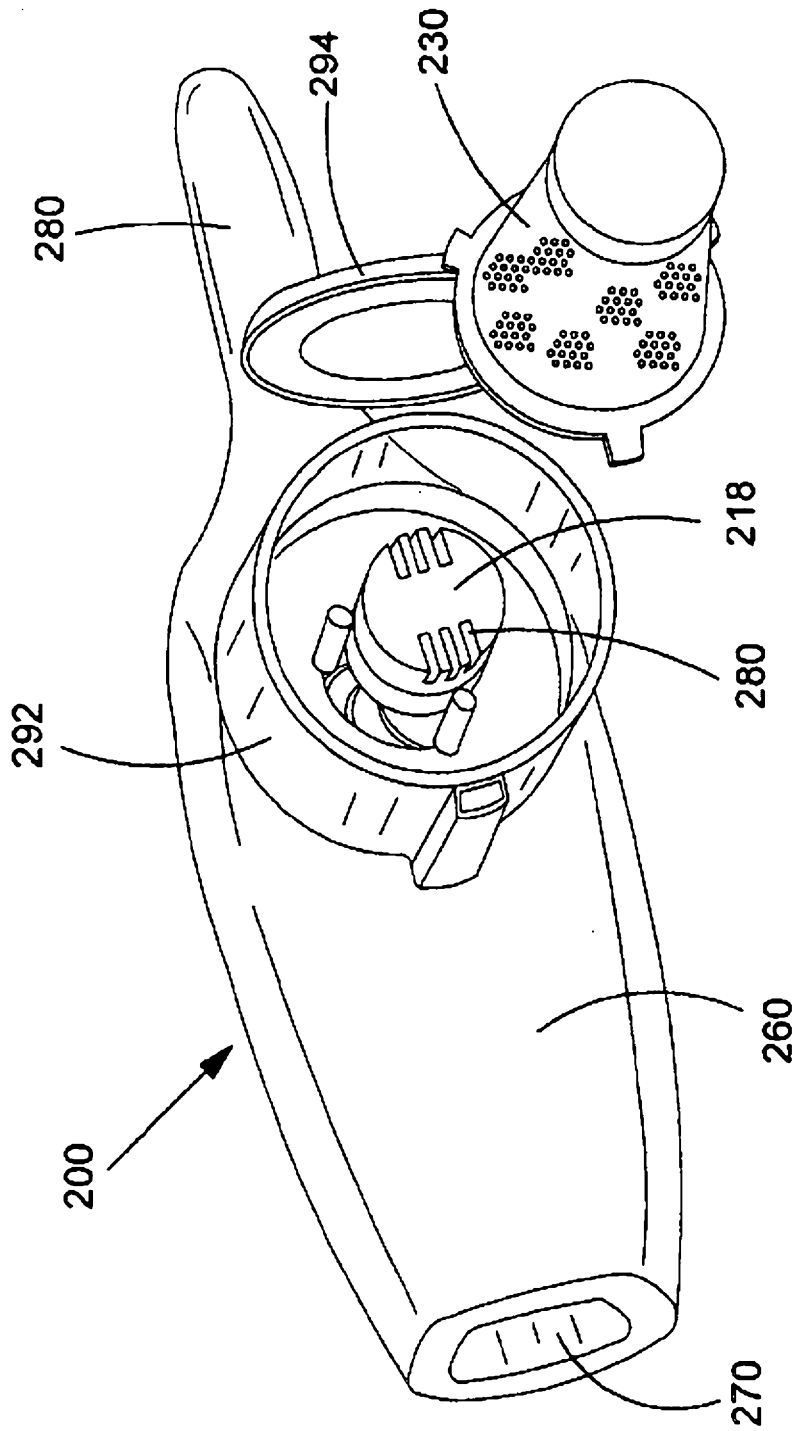

FIG.9

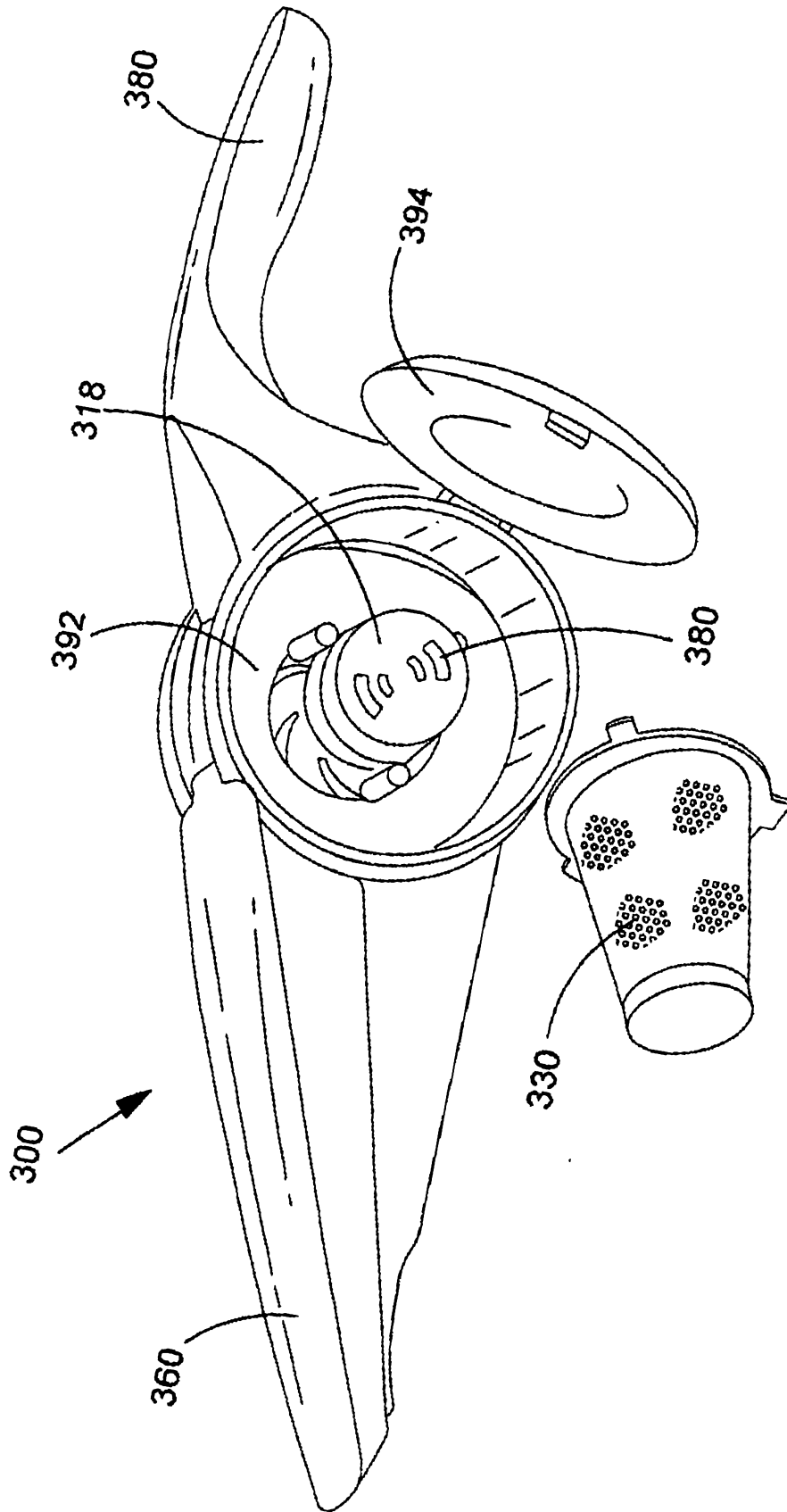

FIG.11

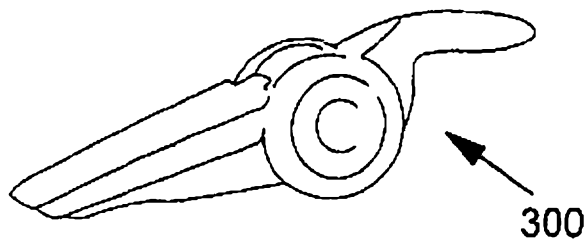

FIG. 12A

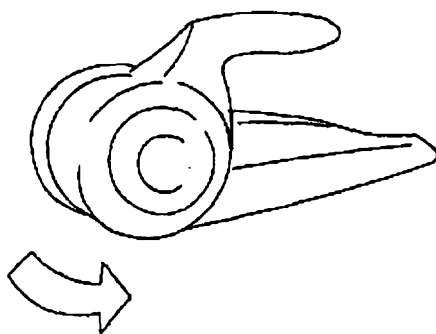

FIG. 12B

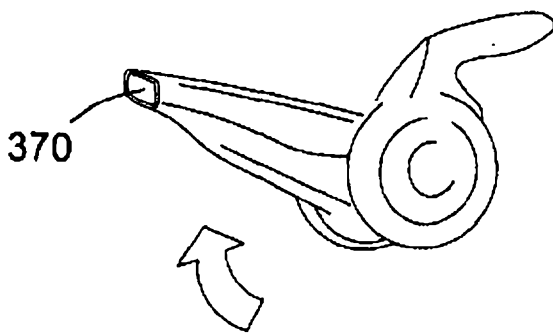

FIG. 12C

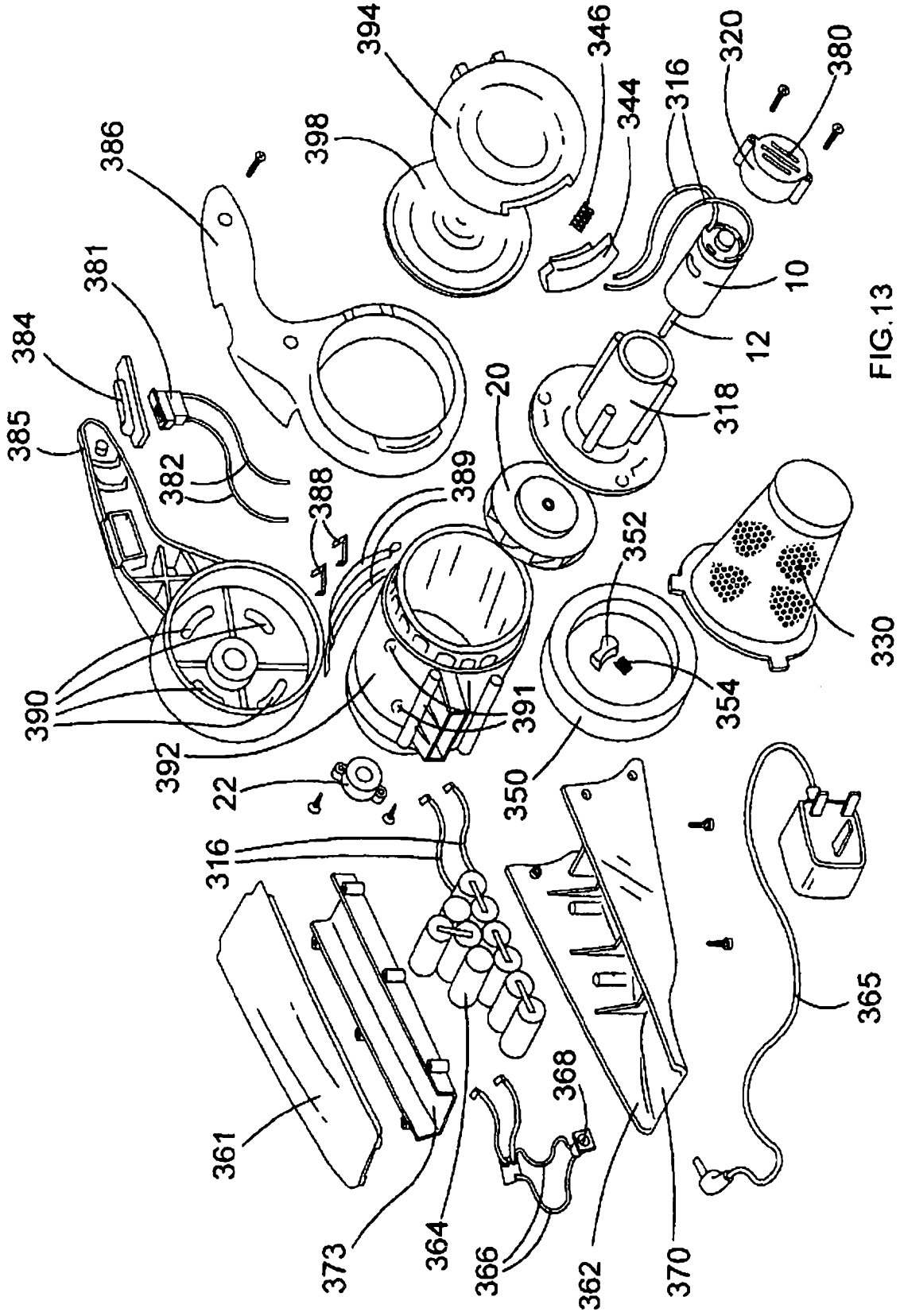

FIG.13