

(No Model.)

2 Sheets—Sheet 1.

A. W. PRITCHARD.

PLATEN SHIFTING ATTACHMENT FOR TYPE WRITING MACHINES.

No. 284,231.

Patented Sept. 4, 1883.

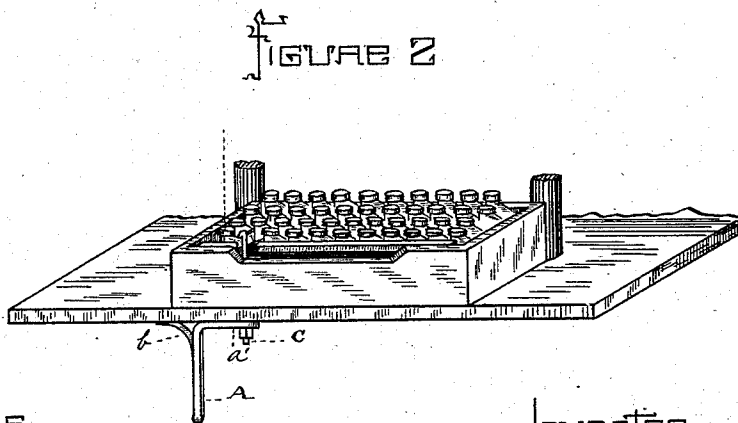
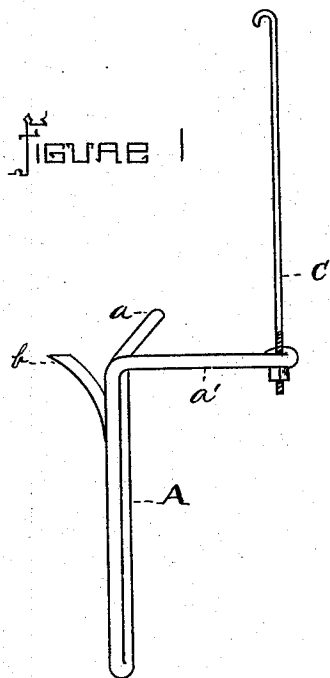

Witnesses.
Halter Reed
Jacob Reed

Inventor
Arthur W. Pritchard,
by
Frank M. Reed, Atty

(No Model.)

2 Sheets—Sheet 2.

A. W. PRITCHARD.

PLATEN SHIFTING ATTACHMENT FOR TYPE WRITING MACHINES.

No. 284,231.

Patented Sept. 4, 1883.

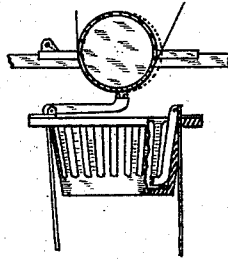

FIGURE 1.

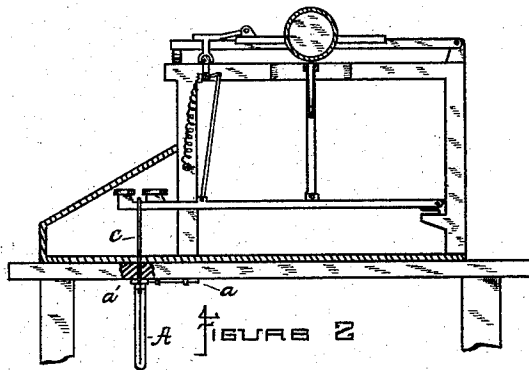

FIGURE 2.

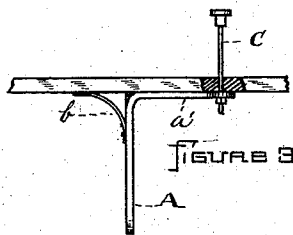

FIGURE 3.

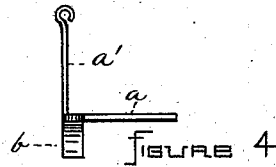

FIGURE 4.

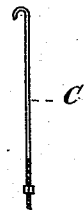

FIGURE 5.

Witnesses—

Halter Reese
Jacob Reese

Inventor—

Arthur W Pritchard
by
Frank M Reese, atty.

UNITED STATES PATENT OFFICE.

ARTHUR W. PRITCHARD, OF ALLEGHENY, PENNSYLVANIA.

PLATEN-SHIFTING ATTACHMENT FOR TYPE-WRITING MACHINES.

SPECIFICATION forming part of Letters Patent No. 284,231, dated September 4, 1883.

Application filed December 8, 1882. (No model.)

To all whom it may concern:

Be it known that I, ARTHUR W. PRITCHARD, a citizen of the United States, residing at Allegheny city, in the county of Allegheny and State of Pennsylvania, have invented certain new and useful Improvements in Platen-Shifting Attachments for Type-Writing Machines; and I do hereby declare the following to be a full, clear, and exact description of the invention, which will enable others skilled in the art to which it appertains to make and use the same, reference being had to the accompanying drawings and the letters of reference marked thereon, which form a part of this specification.

In the drawings, Figure 1 on Sheet 1 indicates a perspective view of my improved device for operating the platen-shifting mechanism of type-writing machines. Fig. 2 on Sheet 1 indicates a perspective view of the device attached to the key-board of a type-writing machine. Fig. 1 on Sheet 2 indicates a detached view of a disk-basket, a set of type-bars carrying double types mounted therein, a platen or printing-cylinder, and a portion of the platen-carriage. Fig. 2 indicates a view of my improvement attached to the platen shift-key or key-bar, and shows the platen-shifting mechanism mounted in a frame. Fig. 3 indicates a front view of the improvement. Fig. 4 indicates a plan view, and Fig. 5 indicates a view of the connecting-rod for attaching my improvement to the platen shift-key or bar.

Like letters of reference indicate like parts wherever they occur.

My invention relates to an improved attachment adapted for use on that class of type-writing machines which employ different kinds, sizes, or styles of the same letters of type, having double types mounted on the type-bars, and provided with shifting cylinders or platens mounted on their carriages in such a manner as to admit of a limited forward and backward movement of the platen in order to adjust the latter into the proper relation to admit of an impression being made by whichever kind or size of type that may from time to time be desired; and it is especially adapted to the use of what is known as the "Remington Standard Type-Writer No. 2," which is sup-

plied with double types, or has two types—a small and a capital letter—on each type-bar, and the machine is provided with a shifting cylinder or platen capable of a backward and forward adjustment upon its carriage, being held in a forward position by a platen-spring, so that it will print the small letters on the forward part of the double types, and may be forced backward by depressing a platen-shifting key, which communicates through suitable devices that movement to the platen, so that impressions may be made from the capital letters on the back portion of the double types, all of which is well known to those skilled in the art, as the machines referred to are well known and in wide and extensive use.

In the use of double-type writers the platen shift-key must be depressed and held down until the capital or number of capitals are struck that the operator desires to print. This requires the use of one hand, and the operator is confined to the use of the other in striking the capitals. Consequently a considerable loss of time is had, as many capitals are required for headings, &c., and as it is frequently necessary to print the entire body of the articles in capital or large letters.

The object of my invention is to allow the operator the use of both hands in striking the capital or large letters; and this object I have fully obtained by the use of an attachment which may be readily fitted to the platen shift-key or key-bar, and may be actuated by the knee of the operator from time to time, as may be desired.

In the drawings, by reference to Fig. 1 on Sheet 1, it will be observed the attachment is shown as constructed from wire, the use of this material being preferable, though any other may be employed. The attachment is formed by bending a piece of heavy wire double at its middle and pressing the wire together to form a stem of the length desired. The wire is then bent at a point a few inches from its ends in such a manner as to form arms extending at right angles to the stem and to each other.

A indicates the stem.

a and a' indicate the projecting arms.

b indicates a spring formed of a thin flat piece of steel soldered at its lower end to one

100

side of the stem A and extending outward in a curved line in the opposite direction to the arm *a'*.

c indicates a connecting-rod threaded at its lower end, which is adapted to pass through a loop on the end of the arm *a*, and is provided with a nut for securing and adjusting it thereto. The upper portion of this rod *c* is curved to enable it to loop over and engage the platen shift-key or key-bar.

In the use of my improvement a small vertical aperture is made through the bottom of the key-board and the table to allow the connecting-rod *c* to pass through and engage the platen shift-key or key-bar, as is indicated in Fig. 2. A couple of small staples (shown in Fig. 2, Sheet 2) are then fastened to the underside of the table in a proper position to allow the arm *a* of the device to be slipped into and engage them, which being done the lower end of the connecting-rod *c* is passed through the loop on the end of the arm *a'*, and the device is adjusted into the position shown against the forward part of the lower side of the table of the machine.

The operation of the improvement is as follows: When it is desired to print capital letters, the knee of the operator is pressed outward against the inner side of the downwardly projecting stem A, and the latter swings up toward the lower surfaces of the table, turning upon its arm or pivot *a*, which, as before stated, engages in the staples on the lower surface of the table. This causes a retrograde movement of the arm *a'* and the connecting-rod *c*, thus drawing down the platen shift-key bar, which in its turn communicates motion through the platen-shifting mechanism to the platen, forcing the latter back into the proper position to allow impressions to be made by the action of the capital types on the rear portion of the double-type bars, and the platen will remain in such position until the knee of the operator is withdrawn from the side of the stem A, at which moment the action of the

spring *b* will force the device again into its former position, and the platen will be brought forward and the platen key-bar drawn upward by the action of the platen-spring usually employed for that purpose.

The advantages of my invention are mainly, first, the operator is allowed the use of both hands when printing capitals or changing from one size, kind, or style of type to another; second, the device can be readily adjusted to the existing style of machines without the use of any skilled labor; third, it is very simple and can be adjusted to or removed from the machine in a moment; fourth, although I do not intend to confine myself to any particular size, shape, or kind of material, it can be made very rapidly and cheaply of wire, as before described; and, finally, on account of its small size, weight, &c., it can be transported by mail or express with little cost to the purchaser.

Having described my invention, what I claim is—

1. In combination with the platen shift-key of a type-writing machine, a platen shift attachment consisting of a lever attached to the platen shift-key, a bent lever attached to said first lever and fulcrumed in the table, and a spring attached to said bent lever and adapted to force said lever to its normal position after same has been acted upon by the knee, substantially in the manner and for the purposes described.

2. A platen shift attachment composed of a depending stem or lever, a set of arms projecting at or near right angles to the stem and to each other, a spring attached to the stem and extending in an opposite direction to one of the arms, and a connecting-rod constructed and arranged substantially as and for the purpose set forth.

A. W. PRITCHARD.

Witnesses:

FRANK M. REESE,
WALTER REESE.