

No. 626,647.

Patented June 6, 1899.

G. B. BASSETT.
WATER METER.

(Application filed Mar. 12, 1897. Renewed May 13, 1899.)

(No Model.)

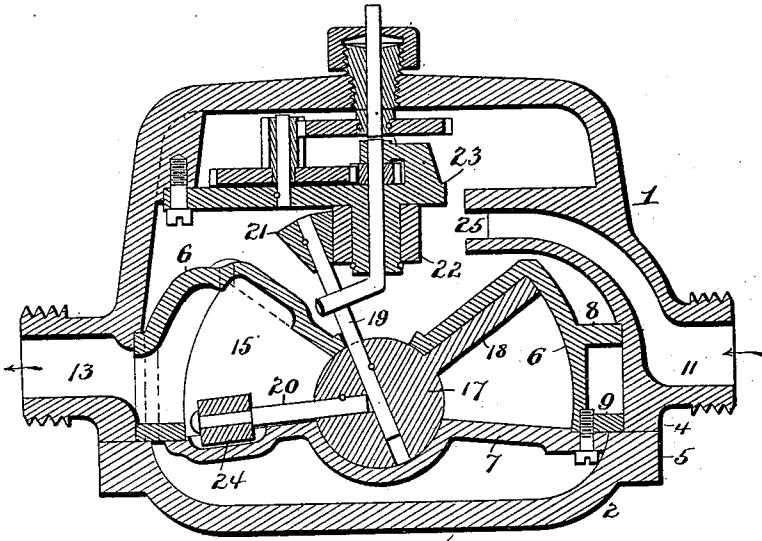
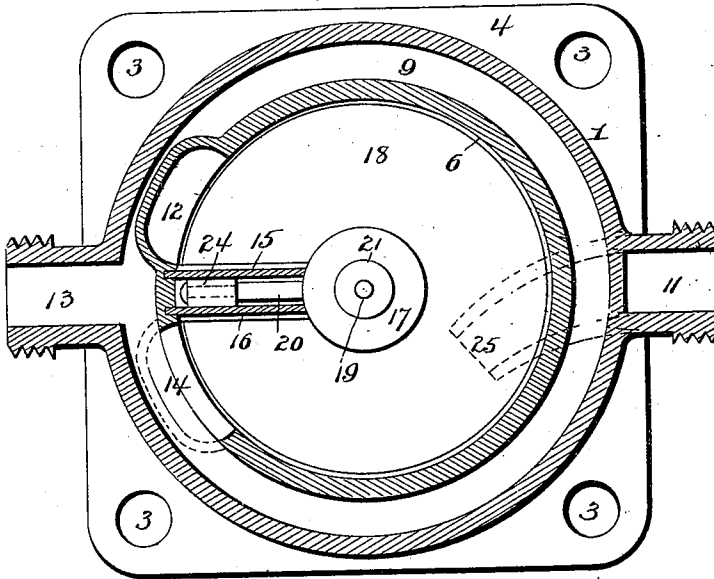

FIG. 1.

FIG. 2.



Witnesses
E. J. Nottingham
M. E. Warwick

Inventor
George B. Bassett
By *H. A. Symour*
Attorney

UNITED STATES PATENT OFFICE.

GEORGE B. BASSETT, OF BUFFALO, NEW YORK.

WATER-METER.

SPECIFICATION forming part of Letters Patent No. 626,647, dated June 6, 1899.

Application filed March 12, 1897. Renewed May 13, 1899. Serial No. 716,707. (No model.)

To all whom it may concern:

Be it known that I, GEORGE B. BASSETT, a resident of Buffalo, in the county of Erie and State of New York, have invented certain new and useful Improvements in Water-Meters; and I do hereby declare the following to be a full, clear, and exact description of the invention, such as will enable others skilled in the art to which it appertains to make and use the same.

This invention has reference to the construction of water-meters, and in particular to meters of the disk type illustrated in Letters Patent No. 501,203, granted to me July 11, 1893.

The invention includes various improvements in the construction of such meters tending to simplicity in construction, certainty in operation, durability, lessening of wear, convenience in packing, and other desirable results.

The invention includes certain details of construction and combination of parts, which will be described in detail and then specifically pointed out in the claims.

In the accompanying drawings, which form part of this specification, Figure 1 is a central vertical section of my improved meter; and Fig. 2 is a horizontal section of my improved meter, showing the disk set level for purpose of illustration.

The outer casing is composed of two detachable parts 1 and 2, which may be fastened together by bolts passing through holes 3 in their meeting flanges 4 and 5, which latter are preferably angular in shape, with opposite sides parallel, the bolt-holes 3 being in the angles.

The measuring-disk chamber is composed of two parts 6 and 7. It is entirely separate and removable from the outer casing and is provided with two projecting annular flanges 8 and 9, in the present instance integral with the parts 6 and on its spherical side, and by means of which flanges the disk-chamber is secured between outer case 2 and an annular seat cut in outer case 1. The disk-chamber and its annular flanges 8 and 9 divide the space surrounding the disk-chamber in the outer case into three compartments, one above the disk-chamber in outer casing 1, contain-

ing the intermediate gearing and communicating with inlet-spud 11 and disk-chamber inlet 12, the other below the disk-chamber in outer casing 2, communicating with inlet-port 12, and the third between the annular flanges 8 and 9, which last space communicates with the outlet-spud 13 and outlet-port 14 of the disk-chamber. Securely mounted between inlet-port 12 and outlet-port 14 and within the disk-chamber are the two partition-plates 15 and 16.

The measuring-disk is composed of a pivot-ball 17 and web 18 and is provided with two controlling-spindles 19 and 20, rigidly mounted in the ball 17. On the top end of spindle 19 is rigidly secured the conical head 21, which bears against the roller 22, fastened on the under side of gear-plate 23. The office of spindle 19 is to keep the disk-web 18 in contact with the ends or cones of the disk-chamber.

The disk-web 18 is slotted, so as to straddle the partition-plates 15 and 16, and in the slot and between partition-plates 15 and 16 extends spindle 20, on the outer end of which is loosely mounted the hard-rubber sliding block 24, which bears against the partition-plates. The office of spindle 20 is to keep the edges of the slot in the disk-web from bearing on the partition-plates and becoming wedged, broken, or worn.

Inlet-spud 11 is extended into the chamber in which spindle 19 moves and is turned to one side, as shown by the dotted lines in Fig. 2, by the nozzle 25, through which the inflowing water acts on spindle 19 and assists it in its annular path proportionately to the amount of water passing through the meter. The inflowing water acting tangentially also causes the water contained in the spindle-chamber to take a circular motion in the same direction as that in which the disk-spindle is moving, which does away with any retarding action such water might have on the annular motion of the disk-spindle.

In the operation of the meter the water first enters the upper chamber and passes from thence into the disk-chamber, and after traversing the disk-chamber and rotating or nutating the piston passes out through the exit 13. The operation of the meter or the fundamental features thereof not herein claimed

are fully disclosed in my patent above referred to and one well known in the art. Hence it is unnecessary to go into the details of the construction and operation of these well-known parts. The lower chamber below plate 7 communicates with the inlet-port 12 and forms a convenient pocket into which gravel or other solids can settle before reaching the disk-chamber.

10 Modifications of the construction herein shown and described may be made in the details of construction of the various parts without departing from the spirit of my invention, and some of the improvements described may be used without others.

15 Having fully described my invention, what I claim as new, and desire to secure by Letters Patent, is—

1. In a disk water-meter, a disk-spindle and means whereby a current of water is directed against said spindle to assist it onward in its path, substantially as and for the purpose set forth.

2. In a disk water-meter, a disk-spindle traveling in a circular path and means whereby the inflowing water is directed against said spindle to assist it onward in its path, substantially as set forth.

3. In a disk water-meter, a water-chamber in which the disk-spindle travels in a circular path, and an inlet-opening entering said chamber at an angle so as to give a circular motion to the water contained in said chamber, to assist said spindle onward in its path, substantially as set forth.

4. In a disk water-meter, a water-chamber in which the disk-spindle moves and an inlet-nozzle entering said chamber so as to direct a current of water tangentially against said

spindle, to assist it onward in its path, substantially as set forth.

5. In a disk water-meter, a water-chamber in which the disk-spindle travels in a circular path and an inlet-nozzle entering said chamber at an angle so as to give a circular motion to the water contained in said chamber, to assist the spindle onward in its path, substantially as set forth.

6. In a disk water-meter, a flat sliding bearing-block loosely supported on a spindle secured to the disk-ball, said block receiving the thrust of the disk on the partition-plate, substantially as set forth.

7. In a disk water-meter, a disk-chamber containing two adjacent separate partition-plates and a flat bearing-block loosely supported on a spindle carried by the disk-ball, said block working between said plates, substantially as set forth.

8. In a disk water-meter a disk, a partition-plate, and a flat sliding bearing-block loosely supported independently of the disk-web and receiving the thrust of the disk on the partition-plate, substantially as set forth.

9. In a disk water-meter, a disk-chamber containing two adjacent separate partition-plates and a hard-rubber bearing-block loosely supported on a spindle mounted in the disk-ball, said spindle working between said plates.

In testimony whereof I have signed this specification in the presence of two subscribing witnesses.

GEORGE B. BASSETT.

Witnesses:

JOHN N. MARLEY,
M. E. WARWICK.