



(51) International Patent Classification:
F02C 9/18 (2006.01)

(21) International Application Number:
PCT/US2012/032030

(22) International Filing Date:
3 April 2012 (03.04.2012)

(25) Filing Language: English

(26) Publication Language: English

(30) Priority Data:
61/472,028 5 April 2011 (05.04.2011) US
61/475,464 14 April 2011 (14.04.2011) US

(71) Applicant (for all designated States except US): THE REGENTS OF THE UNIVERSITY OF CALIFORNIA [US/US]; 1111 Franklin Street, 12th Floor, Oakland, California 94607 (US).

(72) Inventors; and

(75) Inventors/Applicants (for US only): PAPAMOSCHOU, Dimitri [US/US]; 1111 Franklin Street, 12th Floor, Oakland, California 94607 (US). LIU, Feng [US/US]; 1111 Franklin Street, 12th Floor, Oakland, California 94607 (US).

(74) Agents: VINCENT, Lester J. et al.; Blakely Sokoloff Taylor & Zafinan LLP, 1279 Oakmead Parkway, Sunnyvale, California 94085 (US).

(81) Designated States (unless otherwise indicated, for every kind of national protection available): AE, AG, AL, AM, AO, AT, AU, AZ, BA, BB, BG, BH, BR, BW, BY, BZ, CA, CH, CL, CN, CO, CR, CU, CZ, DE, DK, DM, DO, DZ, EC, EE, EG, ES, FI, GB, GD, GE, GH, GM, GT, HN, HR, HU, ID, IL, IN, IS, JP, KE, KG, KM, KN, KP, KR, KZ, LA, LC, LK, LR, LS, LT, LU, LY, MA, MD, ME, MG, MK, MN, MW, MX, MY, MZ, NA, NG, NI, NO, NZ, OM, PE, PG, PH, PL, PT, QA, RO, RS, RU, RW, SC, SD, SE, SG, SK, SL, SM, ST, SV, SY, TH, TJ, TM, TN, TR, TT, TZ, UA, UG, US, UZ, VC, VN, ZA, ZM, ZW.

(84) Designated States (unless otherwise indicated, for every kind of regional protection available): ARIPO (BW, GH, GM, KE, LR, LS, MW, MZ, NA, RW, SD, SL, SZ, TZ, UG, ZM, ZW), Eurasian (AM, AZ, BY, KG, KZ, MD, RU, TJ, TM), European (AL, AT, BE, BG, CH, CY, CZ, DE, DK, EE, ES, FI, FR, GB, GR, HR, HU, IE, IS, IT, LT, LU, LV, MC, MK, MT, NL, NO, PL, PT, RO, RS, SE, SI, SK, SM, TR), OAPI (BF, BJ, CF, CG, CI, CM, GA, GN, GQ, GW, ML, MR, NE, SN, TD, TG).

Published:

— with international search report (Art. 21(3))

(54) Title: QUIET BLEED VALVE FOR GAS TURBINE ENGINE

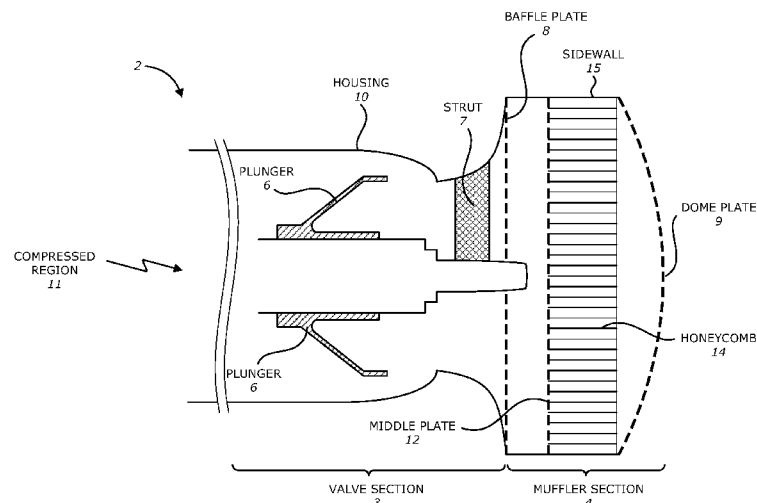

FIG. 9

(57) Abstract: A bleed valve that expels a gas from a compressed region includes a valve section and a muffler section coupled to and located downstream from the valve section. The valve section includes a centerbody and a housing. The centerbody supports a plunger that controls opening and closing of the bleed valve. The centerbody is coupled to the housing by at least one strut disposed substantially radially. The at least one strut may have a cross-section that reduces or suppresses flow separation and vortex shedding from the at least one strut. The muffler section may include a baffle plate and a dome plate. A honeycomb may be installed between the baffle plate and the dome plate. The bleed valve may also include a middle plate on a face of the honeycomb and a conical diverter immediately upstream from the baffle plate. Other embodiments are also described.

QUIET BLEED VALVE FOR GAS TURBINE ENGINE

CROSS REFERENCE TO RELATED APPLICATIONS

[001] This present U.S. Non-Provisional Patent Application claims the benefit of the earlier filing dates of related U.S. Provisional Application No. 61/472,028, filed April 5, 2011 and U.S. Provisional Application No. 61/475,464, filed April 14, 2011. Both U.S. Provisional Application No. 61/472,028 and U.S. Provisional Application No. 61/475,464 are hereby incorporated herein by reference.

TECHNICAL FIELD

[002] An embodiment of the invention relates generally to gas turbine engines using compressor bleed valves.

BACKGROUND

[003] Compressor bleed valves may be found on gas turbine engines powering commercial and military aircraft. At certain stages of the engine operation, the valves bleed high-pressure air from the compressor into the fan duct. The resulting process generates noise that may dominate over other sources of engine noise. Thus, particularly on approach when the engine is throttled back, the noise generated from the valves becomes a significant factor of overall aircraft noise. Bleed valves are typically installed on the high-pressure and intermediate-pressure sections of the compressor, hence the naming High Pressure Bleed Valve (HPBV) and Intermediate Pressure Bleed Valve (IPBV).

[004] Current techniques to suppress noise from bleed valves in gas turbine engines have a number of drawbacks. These existing techniques involve a muffler with one or more stages of perforated plates. The stages of perforated plates in these designs have rendered the resulting design to be bulky and heavy which penalizes engine performance. In addition, adding many suppression stages reduces the mass flow rate such that the valve design is required to be larger which again gives rise to weight issues.

SUMMARY

[005] In one embodiment of the invention, a quiet bleed valve in a gas turbine engine comprises a valve section and a muffler section. The bleed valve expels gas from a compressed region. The valve section includes struts that have a streamlined cross-section to prevent substantial flow separation and suppress vortex shedding. The cross-section of the struts may be in the following shapes: an ellipse, an asymmetric ellipse, a rounded triangle, and an airfoil. In this embodiment, the ellipse and the asymmetric ellipse have an aspect ratio equal to or greater than 2, and the rounded triangle and the airfoil have a chord-to-thickness ratio equal to or greater than 2. The muffler section is coupled to the valve section and is downstream from the valve section. The muffler section includes a honeycomb section that may be enclosed within perforated plates.

[006] In another embodiment of the invention, a quiet bleed valve in a gas turbine engine comprises a valve section and a muffler section. The valve section includes a housing, a centerbody and struts. The struts support the centerbody on the housing. The muffler section is coupled to the valve section and is downstream from the valve section. The muffler section may include a baffle plate, a dome plate placed downstream from the baffle plate, and a honeycomb flow straightener placed between the baffle plate and the dome plate.

[007] In yet another embodiment of the invention, a method of designing and manufacturing a quiet bleed valve includes one or more of the steps of: designing and fabricating streamlined struts that provide structural support for the centerbody of the valve and reduce or suppress flow separation and vortex shedding from the struts; and designing and fabricating a muffler section attached to the downstream part of the valve, the muffler section including at least one honeycomb flow straightener.

[008] In yet another embodiment of the invention, a method of designing and manufacturing quiet bleed valve by modifying an existing bleed valve to reduce its sound, the modification including one or more of the steps of: streamlining support struts in the valve flow path to reduce or suppress flow separation and vortex shedding

from the struts; and inserting at least one honeycomb flow straightener in the muffler section downstream of the valve section.

[009] The above summary does not include an exhaustive list of all aspects of the present invention. It is contemplated that the invention includes all systems, apparatuses and methods that can be practiced from all suitable combinations of the various aspects summarized above, as well as those disclosed in the Detailed Description below and particularly pointed out in the claims filed with the application. Such combinations may have particular advantages not specifically recited in the above summary. Further, the field of the invention may extend to valves used in pneumatic systems other than in gas turbine engines.

BRIEF DESCRIPTION OF THE DRAWINGS

[0010] The embodiments of the invention are illustrated by way of example and not by way of limitation in the figures of the accompanying drawings in which like references indicate similar elements. It should be noted that references to “an” or “one” embodiment of the invention in this disclosure are not necessarily to the same embodiment, and they mean at least one. In the drawings:

[0011] **Figure 1** illustrates a cross section view of one example of a baseline bleed valve design.

[0012] **Figure 2** illustrates frontal and perspective views of one example of a baseline bleed valve design.

[0013] **Figure 3** illustrates far field sound pressure level spectra and noise source map according to one embodiment of the invention.

[0014] **Figure 4A-4C** illustrate perspective views of the bleed valve designs including the baseline struts (**Figure 4A**), and, according to one embodiment of the invention, thin struts (**Figure 4B**) and, according to another embodiment of the invention, struts with elliptical cross section (**Figure 4C**).

[0015] **Figure 5** illustrates the shapes of the streamlined cross-sections of the struts according to one embodiment of the invention.

[0016] **Figure 6** illustrates the shapes of the streamlined cross-sections of the struts according to one embodiment of the invention.

[0017] **Figure 7** illustrates the image profiles of the Mach number contours according to one embodiment of the invention.

[0018] **Figure 8** illustrates the sound pressure level measured with respect to the full-scale frequency according to one embodiment of the invention.

[0019] **Figure 9** illustrates a cross-section view of the bleed valve including a honeycomb according to one embodiment of the invention.

[0020] **Figure 10** illustrates an exemplary assembly of components of the bleed valve including a honeycomb according to one embodiment of the invention.

[0021] **Figure 11** illustrates alternative installations of the honeycomb in the bleed valve according to one embodiment of the invention.

[0022] **Figure 12A-12B** each illustrates a flow diagram of an example method of manufacturing a quiet bleed valve that expels a gas according to one embodiment of the invention.

[0023] **Figure 13** illustrates the noise reductions measured by employing struts with elliptical cross section and honeycomb in the muffler according to one embodiment of the invention.

[0024] **Figure 14** illustrates a diverter that may be included in the bleed valve according to one embodiment of the invention.

[0025] **Figure 15** illustrates an alternative muffler installation with a plurality of perforated plates and a plurality of honeycomb sections according to one embodiment of the invention.

DETAILED DESCRIPTION

[0026] In the following description, numerous specific details are set forth. However, it is understood that embodiments of the invention may be practiced without these specific details. In other instances, well-known circuits, structures, and techniques have not been shown to avoid obscuring the understanding of this description.

[0027] According to the embodiments of the invention, a technique to reduce noise emitted from bleed valves in gas turbine engines of commercial or military aircraft is disclosed. The technique is effective for both High Pressure Bleed Valve (HPBV) and Intermediate Pressure Bleed Valve (IPBV).

[0028] As disclosed herein, the system, method and apparatus of noise suppression from bleed valves employ the following individual approaches and their combinations: (1) Streamlining support struts in the valve structure to suppress vortex shedding, and thus reducing the noise associated with vortex shedding; (2) Installing a honeycomb flow straightener in the muffler section of the valve; and (3) Enhancing the design with optional additions of a middle plate on the upstream side of the honeycomb and a conical diverter immediately upstream of the muffler.

[0029] The following description is divided into three parts. Part I describes the baseline bleed valve and the struts having a streamlined cross-section according to one embodiment of the invention. Part II describes the bleed valves including a honeycomb flow straightener in the muffler section according to one embodiment of the invention. Part III describes alternative enhancements on the bleed valves according to one embodiment of the invention.

PART I: BASELINE BLEED VALVE AND STRUTS HAVING A STREAMLINED CROSS-SECTION

[0030] A turbofan engine is one example in which an embodiment of the invention may be implemented. The turbofan engine includes compressor bleed valves 2, as illustrated in **Figure 1**. Bleed valves are typically installed on the high-pressure and intermediate-

pressure sections of the compressor and as such, the valves are called High Pressure Bleed Valve (HPBV) and Intermediate Pressure Bleed Valve (IPBV).

[0031] **Figure 1** illustrates a cross section view of one example of a baseline bleed valve design. The bleed valve 2 illustrated in **Figure 1** is referred to as the baseline bleed valve. This baseline bleed valve 2 expels a gas from a compressed region 11 and includes a main valve section 3 and a muffler section 4.

[0032] The muffler section 4 of the baseline bleed valve 2 may include a baffle plate 8 and a dome plate 9. As shown in **Figure 1**, the baffle plate 8 may be flat and perforated and the dome plate 9 may be curved and perforated. In other embodiments, the dome plate 9 may be flat.

[0033] The main valve section 3 may include a housing 10, a centerbody 5, a plunger 6 and radial struts 7. The gas from the compressed region 11 flows between the centerbody 5 and the housing 10. The centerbody 5 supports the plunger 6 that translates axially on the centerbody 5 to start or stop the flow. The downstream end of the centerbody 5 (e.g., aft end) may be supported on the housing 10 by struts 7 which are typically located near the minimum area of the valve. The minimum area of the valve is the highest velocity region of the valve. For typical pressure ratios, the flow over the struts may be high-subsonic or supersonic.

[0034] **Figure 2** illustrates frontal and perspective views of an example of a baseline bleed valve design. In this embodiment, the baseline bleed valve design includes three struts 7 and may be coupled to a flange for muffler attachment 12. As shown in **Figure 2** and **Figure 4A**, three struts 7 of the baseline bleed valve 2 extend radially from the centerbody 5 at even azimuthal increments of 120 degrees. In the baseline bleed valve 2, one of the three struts 7 is thicker to allow passage of a pneumatic line that controls the opening and closing of the valve 2. The cross section of the baseline struts 7 is a rounded rectangle.

[0035] While the aforementioned strut 7 details are illustrative of the baseline valve design, the noise reduction approach that follows is generic for any design that employs

the basic arrangement illustrated in **Figure 2**. For instance, this basic arrangement may have fewer or more than three struts 7, the cross section of the baseline struts may be a different blunt shape, the thickness of the baseline struts may also differ, and the struts may be located at different axial locations in the valve.

[0036] **Figure 3** illustrates far field sound pressure level spectra and a noise source map according to one embodiment of the invention. Aero-acoustic measurements using microphone arrays inside an anechoic chamber were performed with the valve section in isolation (without muffler section) and with the combination of valve section and muffler section. For the valve section in isolation, the measured sound pressure levels as shown in **Figure 3** (left) indicate that the valve emits noise much stronger than a turbulent jet issuing from a round nozzle having the same equivalent-diameter as the valve section and operated at the same nozzle pressure ratio as the valve section. Further, the noise source map, as shown in **Figure 3** (right), using beamforming of the array microphones, show that the excess noise originates from the exit plane of the valve section. Among the various valve components that may cause noise from that location, the struts 7 are deemed a prime candidate.

[0037] Accordingly, the first approach in the design of a quiet bleed valve included streamlining support struts in the valve structure. To test this hypothesis, the struts 7 are made very thin since complete removal of the struts 7 would have yielded a structurally unsound design. The redesigned valve including thin struts 7, as shown in **Figure 4B**, was tested acoustically and the excess noise was found to disappear. However, if the very thin struts as shown in **Figure 4B** are found to lack structural support required to support a centerbody 5 of the valve 3, one embodiment of the present invention includes struts 7 that have an elliptical cross-section as shown in **Figure 4C**. The struts that have an elliptical cross-section are referred to as “elliptical struts.” The acoustic measurements performed using elliptical struts reveal excess noise being practically eliminated and yielding acoustic spectra very similar to that of the thin strut.

[0038] **Figure 5** illustrates the shapes of the streamlined cross-sections of the struts 7 according to one embodiment of the invention. In **Figure 5**, the shapes of the

streamlined cross-sections that may include an ellipse, asymmetric ellipse, long ellipse and longer ellipse are compared to the baseline strut cross-section which is a rounded rectangle. In **Figure 5**, the streamlined cross-sections are illustrated in a darker line than the baseline strut cross-sections. Unsteady Reynolds Averaged Navier Stokes (URANS) computation reveals that the shapes of the streamlined cross-sections of the struts 7 in **Figure 5** suppressed vortex shedding and thus suppressed excess noise that is caused by the shedding.

[0039] Referring to **Figure 6**, the shapes of the streamlined cross-sections of the struts 7 are further discussed. In one embodiment, the shape of the streamlined cross-section of the struts 7 may be an ellipse with major axis a and minor axis b , and with the aspect ratio a/b greater than or equal to 2 (**Figure 6a**). In another embodiment, the shape of the streamlined cross-section may be an asymmetric ellipse that includes a forward half of the asymmetric ellipse having a major axis a_1 and a rear half of the asymmetric ellipse having a major axis a_2 . In the asymmetric ellipse, both the forward half and the rear half sharing the same minor axis b and the aspect ratio $(a_1+a_2)/2b$ is equal of greater than 2 (**Figure 6b**). In another embodiment, the shape of the streamlined cross-section may be a rounded triangle with chord-to-thickness ratio a/b equal or greater than 2 (**Figure 6c**). In yet another embodiment, the shape of the streamlined cross-section may be an airfoil with chord-to-thickness ratio a/b equal of greater than 2 (**Figure 6d**). In the airfoil shape embodiment, the NACA 00xx series airfoil shape which includes symmetric sections may be used.

[0040] In other embodiments, if the structural requirement of holding the centerbody 5 may be accomplished with thin support elements, the struts 7 may be shaped into thin plates as shown in **Figure 4B**. Experimentation on this embodiment has shown that an aspect ratio greater than or equal to 5 would reduce vortex shedding, regardless of the shape of the leading and trailing edges of the flat plate comprising the strut.

[0041] As an alternative embodiment, the struts 7 may be placed upstream of the exit plane of the valve 3, in a flow environment that is low subsonic. In this embodiment, the vortex shedding from a blunt-shaped strut may be weak enough in terms of pressure

fluctuation due to the low dynamic pressure of the subsonic flow such that a significant level of noise is not being produced. In order to further reduce the noise being produced, the upstream placement of the struts 7 may also be combined with streamlining the cross-sections of the struts 7 or making the struts 7 very thin.

[0042] **Figure 7** illustrates the image profiles of the Mach number contours according to one embodiment of the invention. As shown in **Figure 7**, vortex shedding is illustrated for the baseline strut (left) and absence of vortex shedding for the strut being modified to have a streamlined cross-section (right).

[0043] **Figure 8** illustrates the sound pressure level measured with respect to the full-scale frequency according to one embodiment of the invention. As shown by the difference between measurements for bleed valves with original (baseline) struts and bleed valves with elliptical struts, the bleed valves with the elliptical struts may eliminate the spikes in the sound pressure level.

[0044] One preferred embodiment may use struts with a cross-section that is streamlined such that substantial flow separation and suppresses vortex shedding are suppressed when operated at the Mach number and Reynolds number environment of the valve struts. Determination of such desired property of the cross-section is based on, for instance: documentation in the literature; demonstrated by an unsteady computation such as URANS, Large Eddy Simulation, or Direct Navier Stokes solver; and demonstration by laboratory experiments.

PART II: BLEED VALVES INCLUDING A HONEYCOMB IN THE MUFFLER SECTION

[0045] The second approach in the design of a quiet bleed valve includes adding a honeycomb flow straightener in the muffler section of the bleed valve. **Figure 9** illustrates a cross-section view of the bleed valve including a honeycomb and **Figure 10** illustrates an exemplary assembly of components of the bleed valve including a honeycomb according to one embodiment of the invention.

[0046] In this embodiment, the baseline bleed valve 2 from **Figure 1** is further modified to comprise a honeycomb flow straightener 14 inside the muffler cavity of muffler section 4. As shown in **Figures 9** and **10**, the muffler section 4 includes the baffle plate 8, the dome plate 9 that is placed downstream from the baffle plate 8, and a honeycomb flow straightener 14 that is placed between the baffle plate 8 and the dome plate 9. The typical muffler allows sufficient space for installation of the honeycomb section as shown in **Figure 9**. However, in cases where a longer honeycomb is desired, the sidewall 15 may be extended to accommodate a longer honeycomb section. An optional spacer 13, shown in **Figure 10**, may be used to support the honeycomb 14 against the dome plate 9 and provide precise control over a gap between the honeycomb and the dome plate.

[0047] In this embodiment, the honeycomb 14 suppresses velocity fluctuations (turbulence) and pressure fluctuations (noise) of the flow emerging from the baffle plate 8. One advantage of the honeycomb 14 is that it is lightweight and presents a minimal obstruction to the flow emerging from the baffle plate 8. Thus, the honeycomb 14 does not impact the mass flow rate through the muffler section 4.

[0048] In some embodiments, the muffler section 4 also includes a middle plate 12 that is perforated and placed on the face of the honeycomb 14 located between the honeycomb 14 and the baffle plate 8, as shown in **Figures 9** and **10**.

[0049] The choice of porosities for the baffle plate 8, middle plate 12, and dome plate 9 of the muffler section 4 may affect the acoustic performance as well as the flow capacity of the valve 2. Typically, the porosities for each of the plates 8, 9, 12 may be selected so that the flow produced in the absence of the muffler section 4 would not be substantially restricted. In one embodiment, to avoid restriction of flow rate, it is desirable to satisfy the following equation: $\beta \geq A_v/A_m$, where A_v is the equivalent flow area of the isolated valve section, A_m is the cross-sectional area of the muffler section 4, and β is the porosity of the baffle plate, middle plate, and/or dome plate. In other embodiments, the acoustic considerations may be a moderately smaller value for β for the baffle plate 8, middle plate 12, and/or dome plate 9. In another embodiment, the acoustic considerations may be $\beta \geq 0.7 A_v/A_m$ for baffle plate 8, middle plate 12, and/or dome plate 9. In yet another

embodiment, the acoustic considerations may be $\beta \geq \alpha A_v/A_m$ for baffle plate 8, middle plate 12, and/or dome plate 9, where α may range from 0.7 to 3. Assuming an area ratio A_m/A_v of approximately 5, the porosities of the baffle plate 8, middle plate 12, and dome plate 9 may each range from 14% to 60%. In one embodiment, the following porosity ranges may be utilized: a porosity range of 25% to 35% for the baffle plate 8, 15% to 25% for the middle plate 12, and 15% to 25% for the dome plate 9. If the valve 2 has an area ratio A_m/A_v that is very different from 5, the porosities of each of the plates 8, 9, 12 may be selected accordingly to prevent substantial flow restriction.

[0050] **Figure 11** illustrates alternative installations of the honeycomb in the bleed valve according to one embodiment of the invention. **Figure 11a** shows the baseline muffler section 4 that includes the baffle plate 8 located on the upstream end of the muffler section 4 and the dome plate 9 located on the downstream end of the muffler section 4. In the embodiment illustrated in **Figure 11b**, the muffler section 4 includes a honeycomb 14 that spans the entire space between the baffle plate 8 and the dome plate 9. While the arrangement in **Figure 11b** provides the maximum length of honeycomb 14, it may lead to non-uniformity of the flow field because the flow is ducted into the honeycomb immediately past the baffle plate 8. In the embodiment illustrated in **Figure 11c**, a space is provided between the baffle plate 8 and the honeycomb 14 within the muffler cavity. Experimental and computational mean velocity profiles indicate that this space is useful for allowing the flow to spread between the baffle plate 8 and the honeycomb 14, thus improving the uniformity of the exit flow. In the embodiment shown in **Figure 11d**, the honeycomb 14 has flat faces and its installation allows for a space between the baffle plate 8 and the entrance to the honeycomb 14 as well as space between the exit of the honeycomb 14 and the dome plate 9. Acoustic experiments indicate that the arrangement in **Figure 11d** provides superior noise reduction, because the aft space enables any fluctuations that emerge from the honeycomb 14 to die down before the dome plate.

[0051] The embodiment illustrated in **Figure 11e** depicts a variation of the arrangement in **Figure 11d** that includes the addition of the middle plate 12 which is a perforated plate that is placed on the upstream face of the honeycomb 14. In this embodiment, the middle plate 12 may enhance the spreading of the flow before the flow enters the honeycomb 14

and may also provide structural support for the honeycomb 14. **Figure 11f** illustrates an embodiment, which is a variant of the design of **Figure 11e**. In the embodiment of **Figure 11f**, the shape of the aft (downstream) end of the honeycomb 14 follows the curvature of the dome plate 9.

[0052] While all of the embodiments illustrated in **Figures 11a-11f** have the ability to suppress noise, the embodiment of **Figure 11d** may be the preferred embodiment. In the embodiment of **Figure 11d**, the honeycomb 14 length may be approximately 50% of the distance between the baffle plate 8 and the dome plate 9 as measured along the centerline of the valve 2. The honeycomb 14 may be placed such that the axial lengths of the space between the baffle plate 8 and the entrance (e.g., upstream side) of the honeycomb 14 and the space between the exit (e.g., downstream side) of the honeycomb 14 and the dome plate 9 are approximately equal. The axial lengths are measured along the centerline of the valve 2. In the embodiments of **Figures 11a-11f**, the overall length of the muffler section 4 may be adjusted to provide sufficient space for the honeycomb 14 and, where applicable, the spaces between the baffle plate 8 and the honeycomb 14 and between the honeycomb 14 and the dome plate 9. These adjustments are subject to constraints arising from the integration of the valve 2 with the engine components.

[0053] The benefit of the honeycomb 14 may increase with decreasing cell size and with lower practical limit dictated by structural considerations and the concern for blockage from impurities in the bleed air. While in the preferred embodiment, the honeycomb 14 cell size may range from approximately 1/16-inch to approximately 1/8-inch, larger cell sizes, such as 1/4-in or 1/2-in, may also be deemed satisfactory. In another embodiment, the honeycomb may have non-uniform cell size in a manner that may promote flow uniformity and suppression of acoustic fluctuations.

[0054] The following embodiments of the invention may be described as a process, which is usually depicted as a flowchart, a flow diagram, a structure diagram, or a block diagram. Although a flowchart may describe the operations as a sequential process, many of the operations can be performed in parallel or concurrently. In addition, the

order of the operations may be re-arranged. A process is terminated when its operations are completed. A process may correspond to a method, a procedure, etc.

[0055] **Figure 12A-12B** each illustrate a flow diagram of an example method of manufacturing a quiet bleed valve that expels a gas by modifying the design of the baseline bleed valve according to embodiments of the invention. As discussed above, the baseline bleed valve includes a valve section formed between a centerbody and a housing. The baseline bleed valve expels gas from a compressed region and this expelled gas flows between the centerbody and the housing. The centerbody is attached to the housing by at least one strut that is disposed substantially radially. The baseline bleed valve also includes a muffler section that is attached to the valve section and is located downstream from the valve section. The muffler section includes a baffle plate and a dome plate. The baffle plate is placed upstream of the dome plate.

[0056] In **Figure 12A**, the method 100 illustrates one embodiment of a method of manufacturing a quiet bleed valve that produces a reduced amount of noise in comparison to this baseline bleed valve. Using the baseline bleed valve, the method 100 comprises streamlining a cross-sectional shape of the at least one strut to reduce or suppress flow separation and vortex shedding from the at least one strut (Block 110). The streamlining may be performed by a machine during manufacture of the quiet bleed valve.

[0057] In **Figure 12B**, the method 200 illustrates one embodiment of a method of manufacturing a quiet bleed valve that produces a reduced amount of noise in comparison to this baseline bleed valve. Using the baseline bleed valve, the method 200 comprises inserting at least one honeycomb flow straightener in the muffler section (Block 210). The inserting of the at least one honeycomb may be performed by a machine during manufacture of the quiet bleed valve.

[0058] It is contemplated that the methods illustrated in **Figures 12A** and **12B** may be used in combination in order to further reduce the noise of the baseline bleed valve.

[0059] In other embodiments, the bleed valve that includes the honeycomb in the muffler section may also comprise struts that have a cross-section that is streamlined to prevent

substantial flow separation and suppress vortex shedding, as illustrated in **Figures 4, 5 and 6C**.

PART III: ALTERNATIVE ENHANCEMENTS

[0060] The approaches described in Part I (struts with a streamlined cross-section) and Part II (a muffler section including a honeycomb) work satisfactorily in isolation. However, the best acoustic results may be obtained by combining the two approaches. Example of the acoustic benefit of combining these two approaches is depicted in the acoustic results of **Figure 13**. In **Figure 13**, the curves labeled A correspond to the baseline valve and the curves labeled B correspond to the modified valve using struts with elliptical cross-section from **Figure 6a** and the honeycomb in the muffler from **Figure 11d**. It is noted that the sound pressure levels (SPL), overall sound pressure level (OASPL), and perceived noise level (PNL) are substantially lower for the modified valve.

[0061] Other alternative enhancements may further be included in the bleed valve that employs either of the approaches in Parts I and II or in the bleed valve that employs the combination of the approaches in Parts I and II. For instance, **Figure 14** illustrates a conical diverter that may be included in the bleed valve according to one embodiment of the invention. The conical diverter 16 as shown in **Figure 14** (left) may be included in as an optional element to the embodiment of the bleed valve 2 shown in **Figure 11d**. However, the conical diverter 16 may be an additional optional element to any of the embodiments of the bleed valve 2 illustrated in **Figures 11a-11f**. As shown in **Figure 14**, the conical diverter 16 may be placed immediately upstream of the baffle plate 8. Using the diverter 16, more flow from the valve may be forced towards the perimeter of the muffler section thereby improving the uniformity of the muffler flow field. The conical diverter 16 may be solid 16a or porous 16b. However, using the porous conical diverter 16b, a portion of the flow may be sent near the centerline of the bleed valve 2 which avoids creating a dead flow region that may cause a non-uniform exit flow.

[0062] **Figure 15** illustrates an alternative muffler installation with a plurality of perforated plates and a plurality of honeycomb sections according to one embodiment of the invention. As shown in **Figure 15**, the muffler section includes a series of

honeycomb sections 14a, 14b placed in sequence and surrounded by perforated plates. For instance, the first and second honeycombs 14a, 14b are provided between the baffle plate 8 and dome plate 9 in the muffler cavity. In this embodiment, a space is provided between the baffle plate 8 and the first honeycomb 14a and another space is provided between the second honeycomb 14b and the dome plate 9. This embodiment further includes the addition of the first middle plate 12a that is placed on the upstream face of the first honeycomb 14a and the addition of the second middle plate 12b on the upstream face of the second honeycomb 14b. The honeycomb sections may have the same or different cell sizes and cell patterns. In some embodiments, a space may be provided between the first honeycomb's 14a downstream face and the second middle plate 12b. In other embodiments, no space is provided between the first honeycomb's 14a downstream face and the second middle plate 12b.

[0063] While the invention has been described in terms of several embodiments, those of ordinary skill in the art will recognize that the invention is not limited to the embodiments described, but can be practiced with modification and alteration within the spirit and scope of the appended claims. The description is thus to be regarded as illustrative instead of limiting. There are numerous other variations to different aspects of the invention described above, which in the interest of conciseness have not been provided in detail. Accordingly, other embodiments are within the scope of the claims.

CLAIMS

What is claimed is:

1. A bleed valve for expelling a gas from a compressed region, the bleed valve comprising:
 - a valve section including a centerbody and a housing, the gas flowing between the centerbody and the housing, the centerbody being coupled to the housing by at least one strut disposed substantially radially, the at least one strut having a cross-section that reduces or suppresses flow separation and vortex shedding from the at least one strut; and
 - a muffler section coupled to the valve section and being downstream of the valve section.
2. The bleed valve of claim 1 wherein the cross-section of the at least one strut is one or more of the following: an ellipse, an asymmetric ellipse, a rounded triangle, and an airfoil.
3. The bleed valve of claim 2, wherein the ellipse and the asymmetric ellipse have an aspect ratio equal to or greater than 2, and the rounded triangle and the airfoil have a chord-to-thickness ratio being equal to or greater than 2.
4. The bleed valve of claim 1 wherein the muffler section comprises at least one perforated plate, wherein the gas flows through the at least one perforated plate.
5. The bleed valve of claim 4, wherein the at least one perforated plate comprises two perforated plates being a baffle plate and a dome plate, the baffle plate being placed upstream of the dome plate.
6. The bleed valve of Claim 5 wherein the dome plate is flat or curved.
7. The bleed valve of Claim 5, further comprising a conical diverter placed immediately upstream of the baffle plate, the conical diverter being porous or solid.

8. The bleed valve of claim 1, wherein the centerbody supports a plunger that controls the opening and closing of the bleed valve.

9. A bleed valve for expelling a gas from a compressed region, the bleed valve comprising:

a valve section including a centerbody and a housing, the gas flowing between the centerbody and the housing, the centerbody being coupled to the housing by at least one strut disposed substantially radially; and

a muffler section coupled to the valve section and being downstream of the valve section, the muffler section comprising at least one perforated plate and at least one honeycomb, wherein the gas flows through the at least one perforated plate and the at least one honeycomb.

10. The bleed valve of claim 9 wherein the at least one perforated plate comprises two perforated plates being a baffle plate and a dome plate, the baffle plate being placed upstream of the dome plate; and the at least one honeycomb is a honeycomb section located between the baffle plate and the dome plate.

11. The bleed valve of Claim 10 wherein the dome plate is flat or curved.

12. The bleed valve of claim 10 wherein the honeycomb section fills the entire space between the baffle plate and the dome plate.

13. The bleed valve of claim 10 wherein a space is provided between the honeycomb section and the baffle plate.

14. The bleed valve of claim 10 wherein a space is provided between the honeycomb section and the dome plate.

15. The bleed valve of claim 10 wherein a space is provided between the honeycomb section and the baffle plate and a space is provided between the honeycomb section and the dome plate.

16. The bleed valve of claim 13 further comprising a middle perforated plate coupled to an upstream face of the honeycomb section.

17. The bleed valve of claim 15 further comprising a middle perforated plate coupled to an upstream face of the honeycomb section.

18. The bleed valve of Claim 11 wherein the honeycomb faces are flat.

19. The bleed valve of Claim 11 wherein a downstream face of the honeycomb section conforms to the curvature of the dome plate.

20. The bleed valve of claim 10, further comprising a conical diverter placed immediately upstream of the baffle plate, the conical diverter being porous or solid.

21. The bleed valve of Claim 9, wherein the at least one perforated plate comprises a plurality of perforated plates and the at least one honeycomb comprises at least one honeycomb section inserted between adjacent perforated plates.

22. The bleed valve of Claim 9, wherein the centerbody supports a plunger that controls the opening and closing of the bleed valve.

23. The bleed valve of Claim 9, wherein the at least one strut has a cross-section that reduces or suppresses flow separation and vortex shedding from the at least one strut.

24. The bleed valve of claim 23 wherein the cross-section of the at least one strut is one or more of the following: an ellipse, an asymmetric ellipse, a rounded triangle, and an airfoil.

25. The bleed valve of claim 24, wherein the ellipse and the asymmetric ellipse have an aspect ratio equal to or greater than 2, and the rounded triangle and the airfoil have a chord-to-thickness ratio being equal to or greater than 2.

26. A bleed valve for expelling a gas from a compressed region, the bleed valve comprising:

a valve section including a centerbody and a housing, the gas flowing between the centerbody and the housing, the centerbody being coupled to the housing by at least one strut disposed substantially radially, the at least one strut having a cross-section that reduces or suppresses flow separation and vortex shedding from the at least one strut; and

a muffler section coupled to the valve section and being downstream of the valve section, the muffler section comprising at least one perforated plate and at least one honeycomb, wherein the gas flows through the at least one perforated plate and the at least one honeycomb.

27. A method of reducing noise from a bleed valve that expels a gas from a compressed region, the bleed valve including a valve section includes a centerbody and a housing, the gas flowing between the centerbody and the housing, the centerbody being coupled to the housing by at least one strut disposed substantially radially, and a muffler section coupled to the valve section and downstream of the valve section, the method comprising:

streamlining a cross-sectional shape of the at least one strut to reduce or suppress flow separation and vortex shedding from the at least one strut.

28. The method of Claim 27 wherein the cross-section of the at least one strut is one or more of the following: an ellipse, an asymmetric ellipse, a rounded triangle, and an airfoil.

29. The method of Claim 28, wherein the ellipse and the asymmetric ellipse have an aspect ratio equal to or greater than 2, and the rounded triangle and the airfoil have a chord-to-thickness ratio being equal to or greater than 2.

30. A method of reducing noise from a bleed valve that expels a gas from a compressed region, the bleed valve including a valve section includes a centerbody and a housing, the gas flowing between the centerbody and the housing, the centerbody being coupled to the housing by at least one strut disposed substantially radially, and a muffler section coupled to the valve section and downstream of the valve section, the muffler section including a baffle plate and a dome plate, the baffle plate being placed upstream of the dome plate, the method comprising:

inserting at least one honeycomb flow straightener in the muffler section.

31. The method of Claim 30 wherein the honeycomb flow straightener is a honeycomb section, and wherein inserting the at least one honeycomb flow straightener

in the muffler section includes placing the honeycomb section between the baffle plate and the dome plate.

32. The method of claim 31, wherein the dome plate is flat or curved.

33. The method of claim 31, wherein inserting the at least one honeycomb flow straightener in the muffler section includes filling the entire space between the baffle plate and the dome plate with the honeycomb section.

34. The method of claim 31 wherein inserting the at least one honeycomb flow straightener in the muffler section includes providing a space between the honeycomb section and the baffle plate.

35. The method of claim 31 wherein inserting the at least one honeycomb flow straightener in the muffler section includes providing a space between the honeycomb section and the dome plate.

36. The method of claim 31 wherein inserting the at least one honeycomb flow straightener in the muffler section includes providing a space between the honeycomb section and the baffle plate and providing a space between the honeycomb section and the dome plate.

37. The method of claim 34 further comprising inserting, in the muffler section, a middle perforated plate that is coupled on an upstream face of the honeycomb section.

38. The method of claim 36 further comprising inserting, in the muffler section, a middle perforated plate that is coupled to an upstream face of the honeycomb section.

39. The method of claim 32 wherein the at least one honeycomb flow straightener has flat faces.

40. The method of claim 32 wherein a downstream face of the honeycomb section conforms to the curvature of the dome plate.

41. The method of claim 31, further comprising a conical diverter placed immediately upstream of the baffle plate, the conical diverter being porous or solid.

42. The method of claim 30, wherein said at least one perforated plate comprises a plurality of perforated plates and the at least one honeycomb flow straightener comprises at least one honeycomb section inserted between adjacent perforated plates.

43. The method of claim 30, further comprising streamlining a cross-sectional shape of the at least one strut to reduce or suppress flow separation and vortex shedding from the at least one strut.

44. The method of Claim 43 wherein the cross-section of the at least one strut is one or more of the following: an ellipse, an asymmetric ellipse, a rounded triangle; and an airfoil.

45. The method of Claim 44, wherein the ellipse and the asymmetric ellipse having an aspect ratio equal to or greater than 2, and the rounded triangle and the airfoil having a chord-to-thickness ratio being equal to or greater than 2.

46. A method of reducing noise from a bleed valve that expels a gas from a compressed region, the bleed valve including a valve section includes a centerbody and a housing, the gas flowing between the centerbody and the housing, the centerbody being coupled to the housing by at least one strut disposed substantially radially, and a muffler section coupled to the valve section and downstream of the valve section, the muffler section including a baffle plate and a dome plate, the baffle plate being placed upstream of the dome plate, the method comprising:

inserting at least one honeycomb flow straightener in the muffler section; and
streamlining a cross-sectional shape of the at least one strut to reduce or suppress flow separation and vortex shedding from the at least one strut.

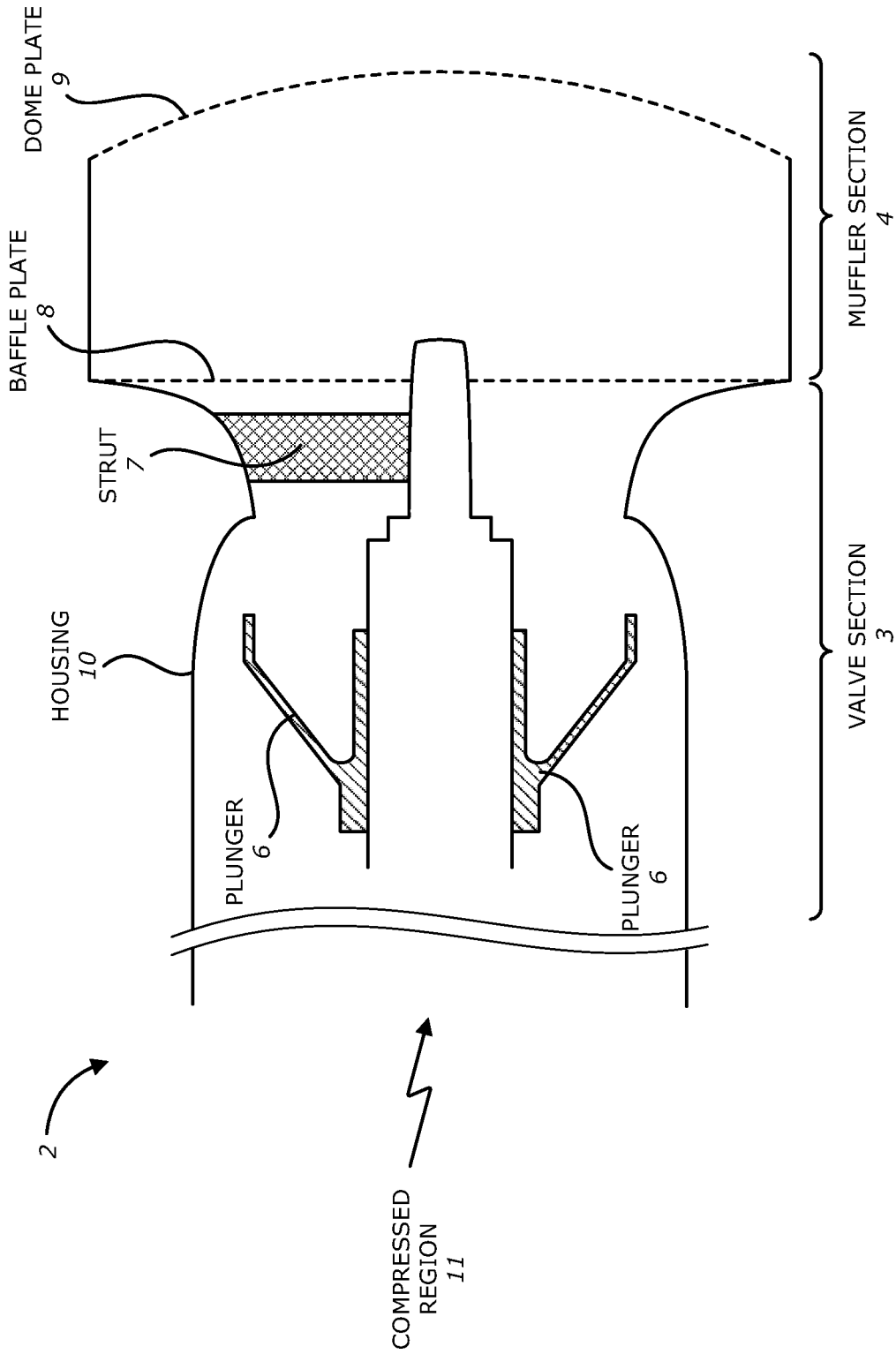

FIG. 1

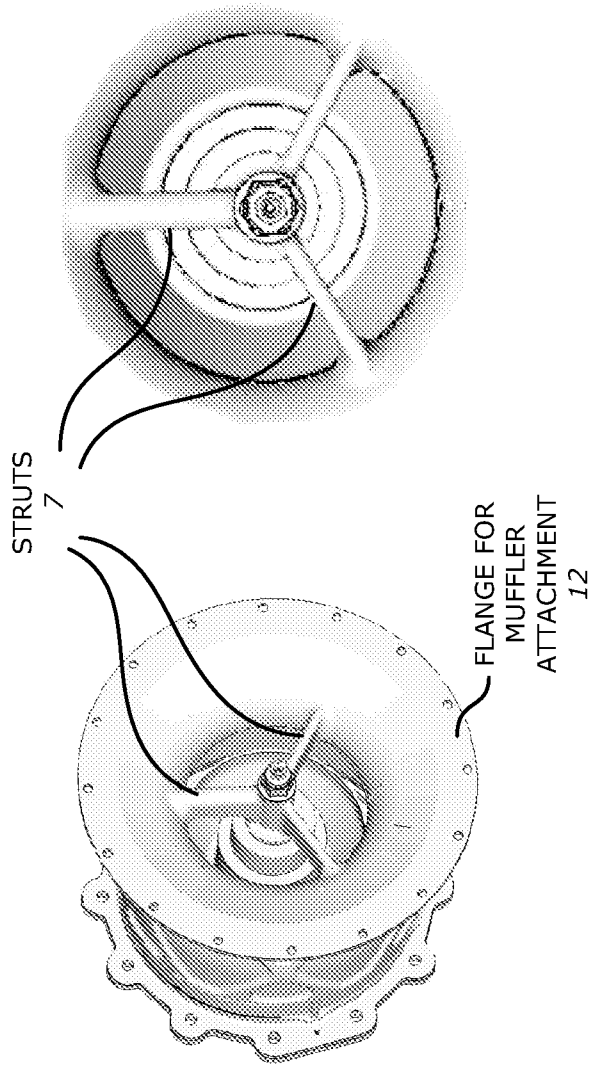

FIG. 2

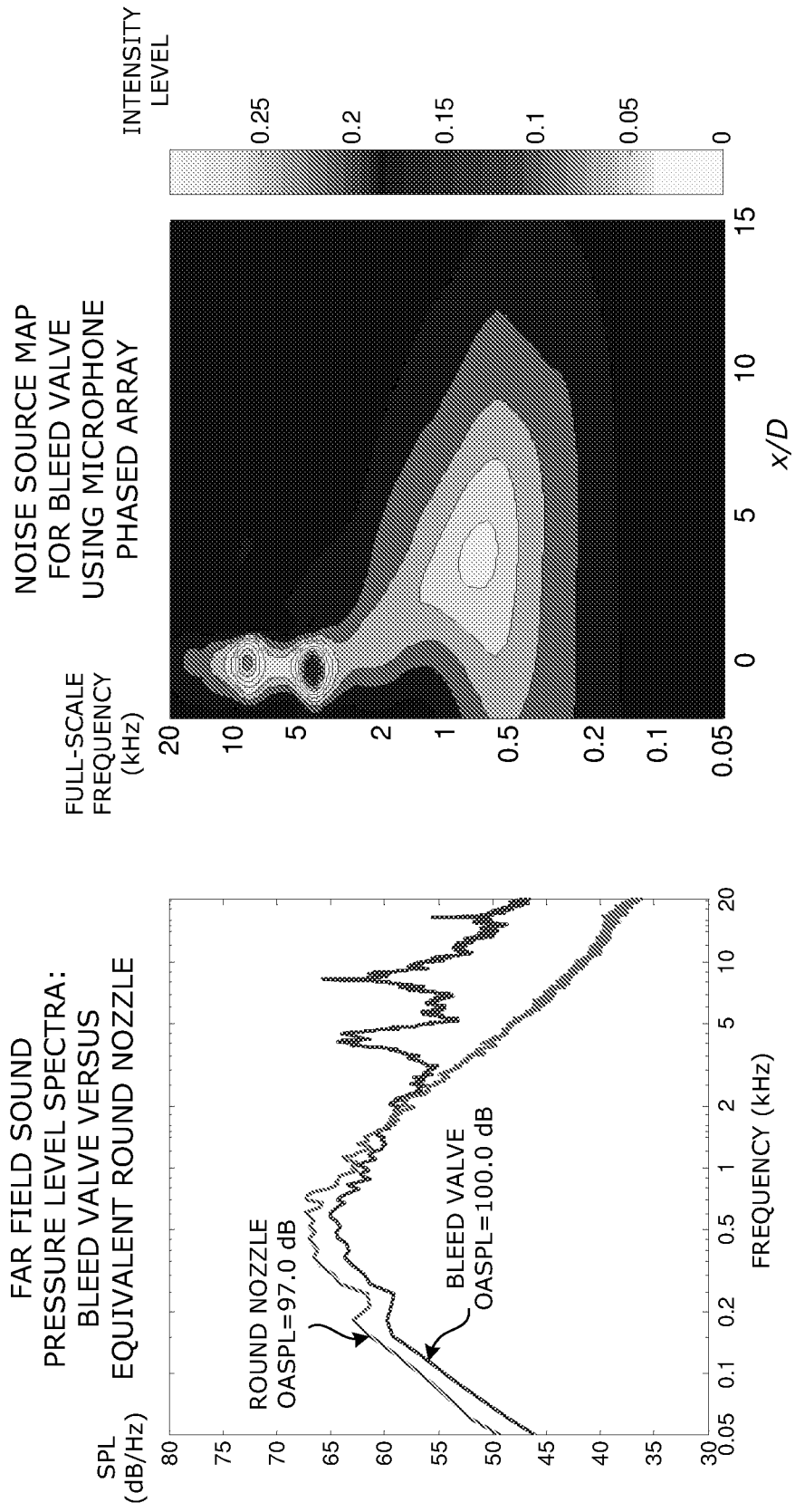

FIG. 3

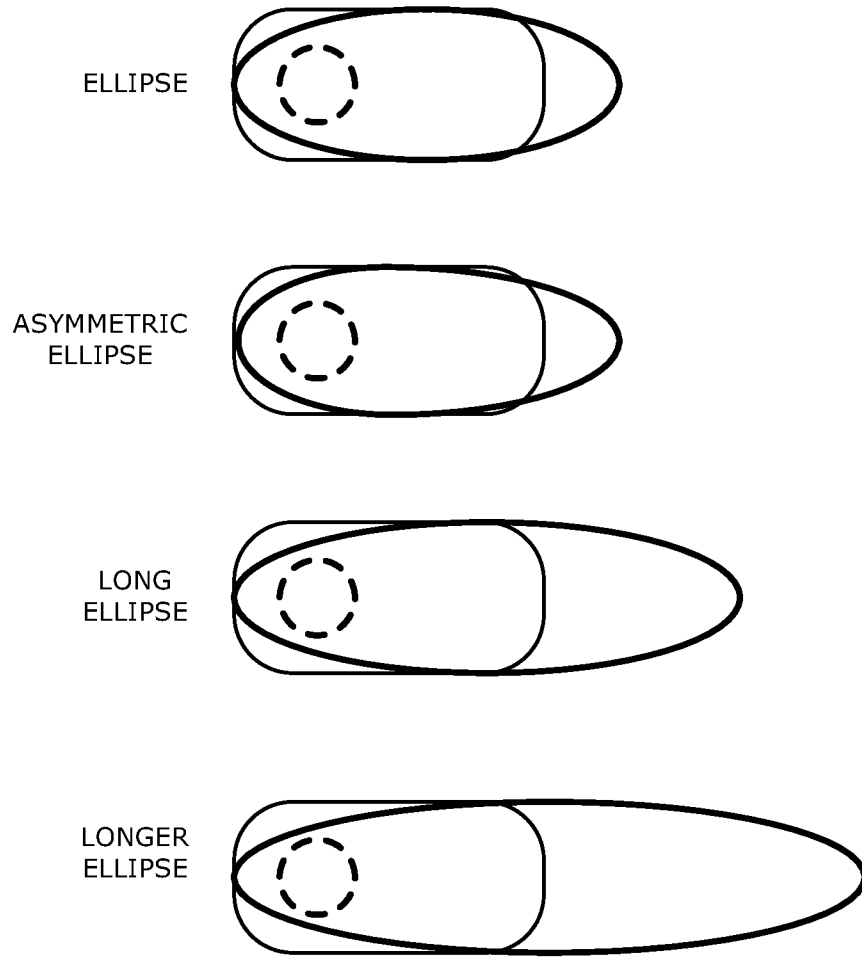

FIG. 5

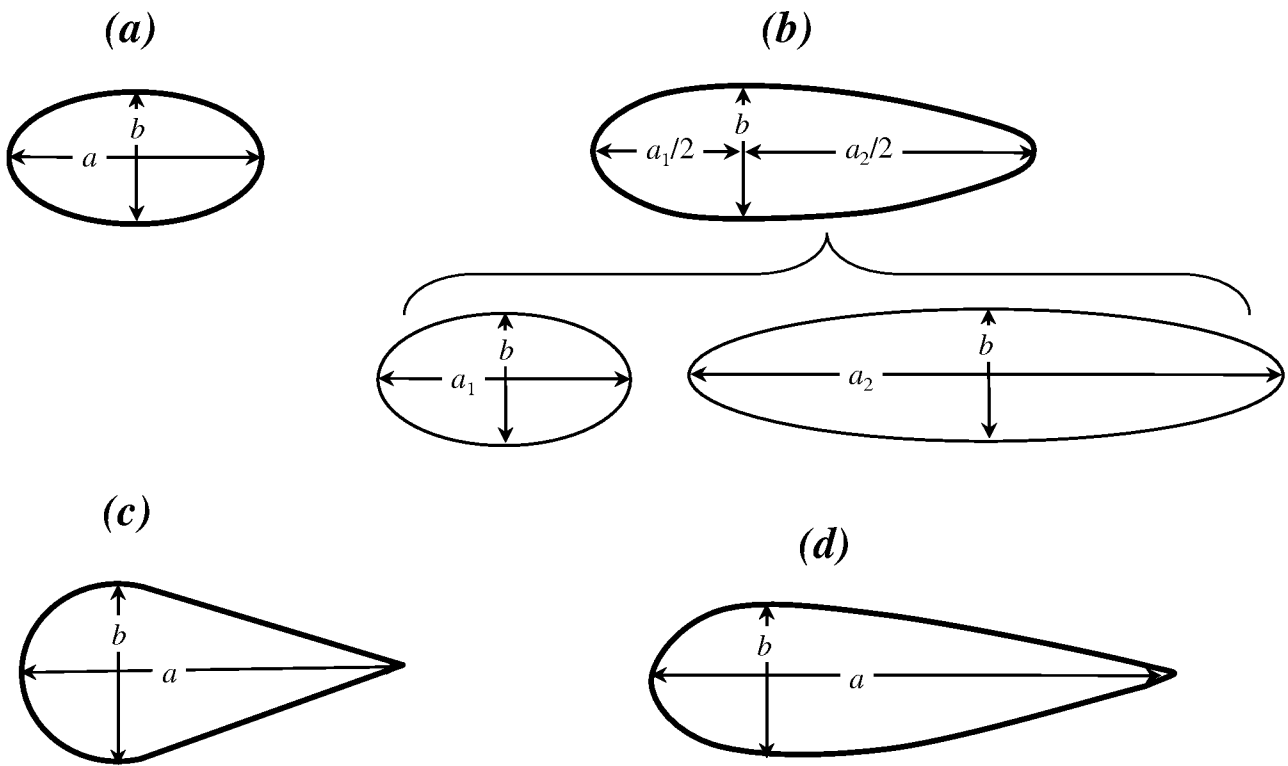
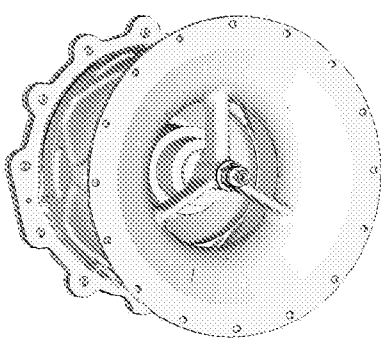
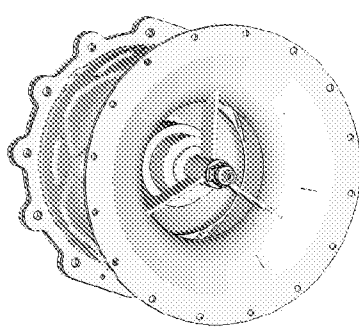

FIG. 6



BASELINE STRUTS

FIG. 4A



THIN STRUTS

FIG. 4B

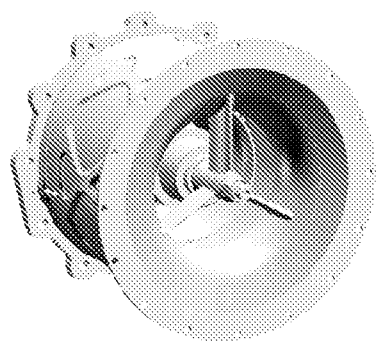

ELLIPTICAL STRUTS

FIG. 4C

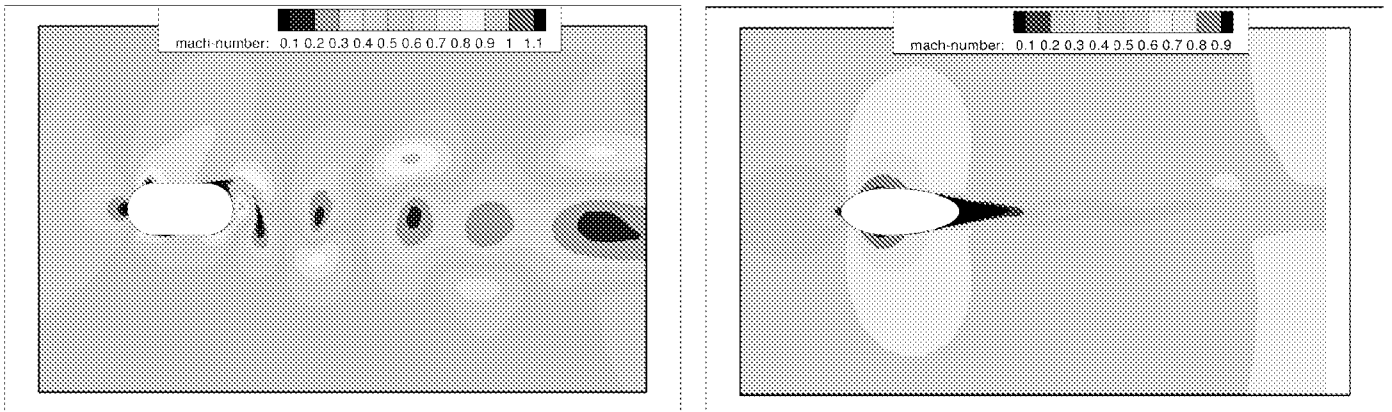

FIG. 7

FAR FIELD SOUND PRESSURE
LEVEL SPECTRA FOR BLEED
VALVE WITH ORIGINAL STRUTS
AND ELLIPTICAL STRUTS

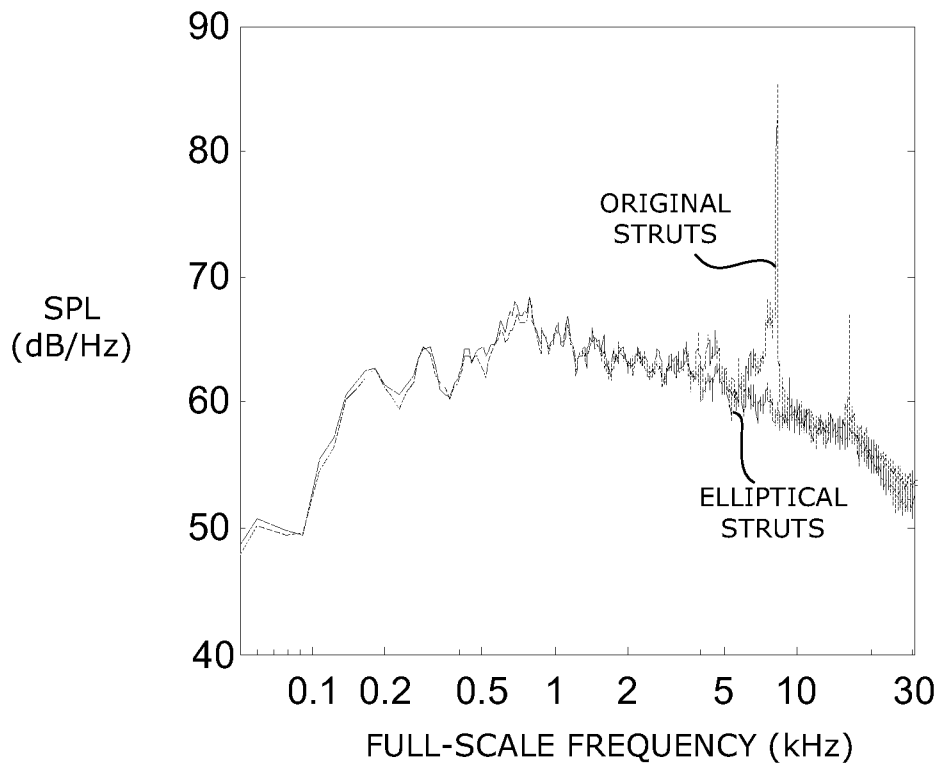

FIG. 8

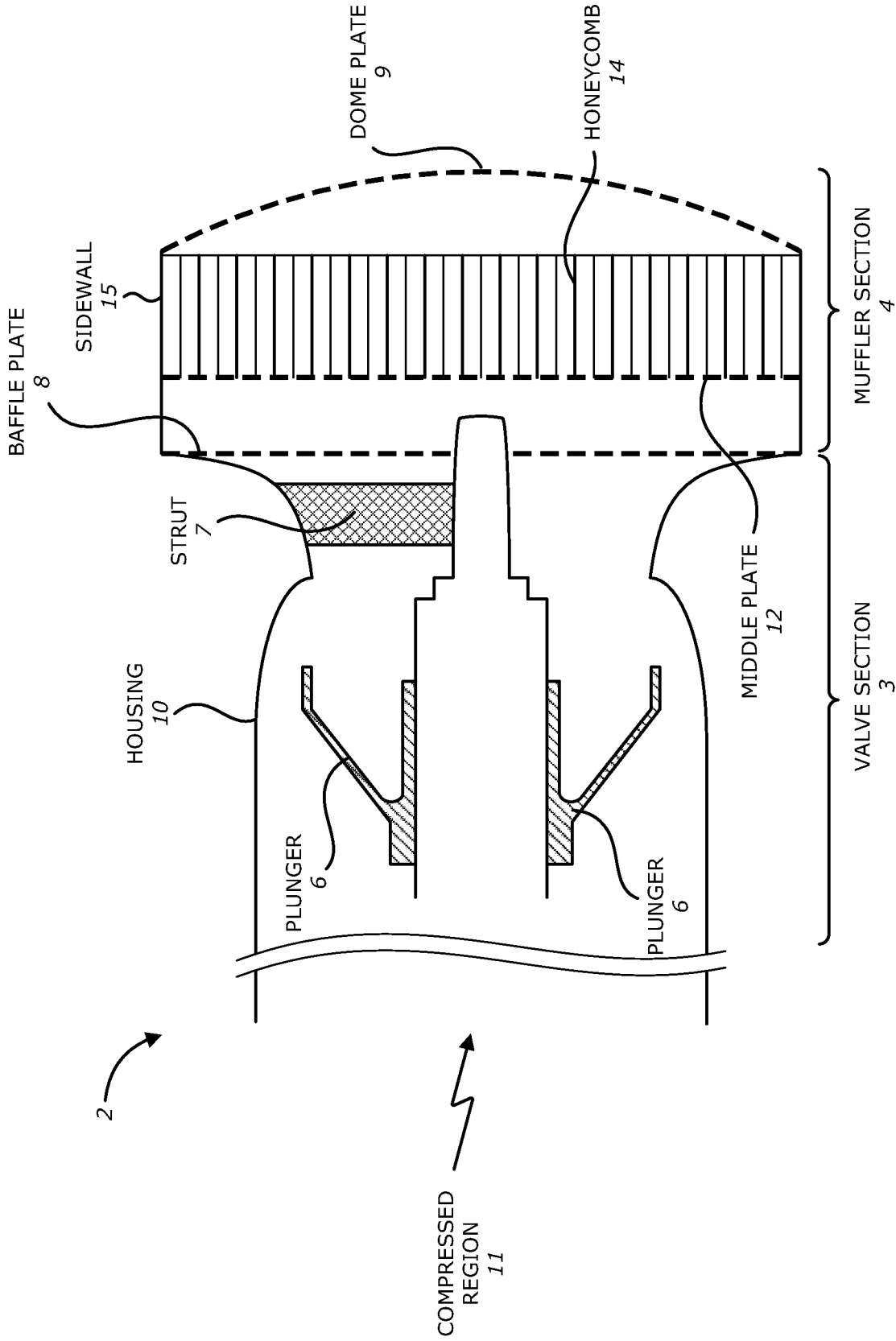

FIG. 9

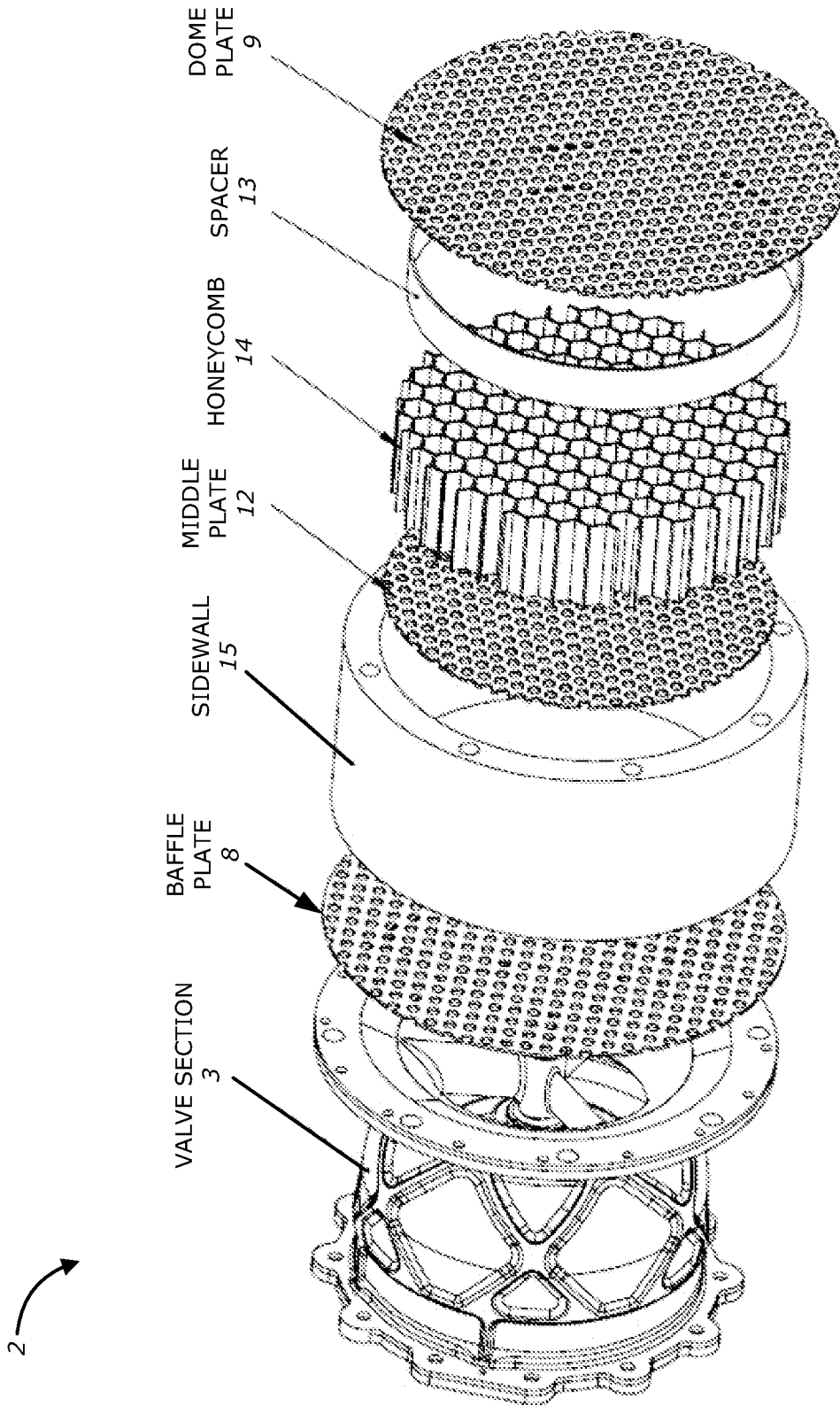

FIG. 10

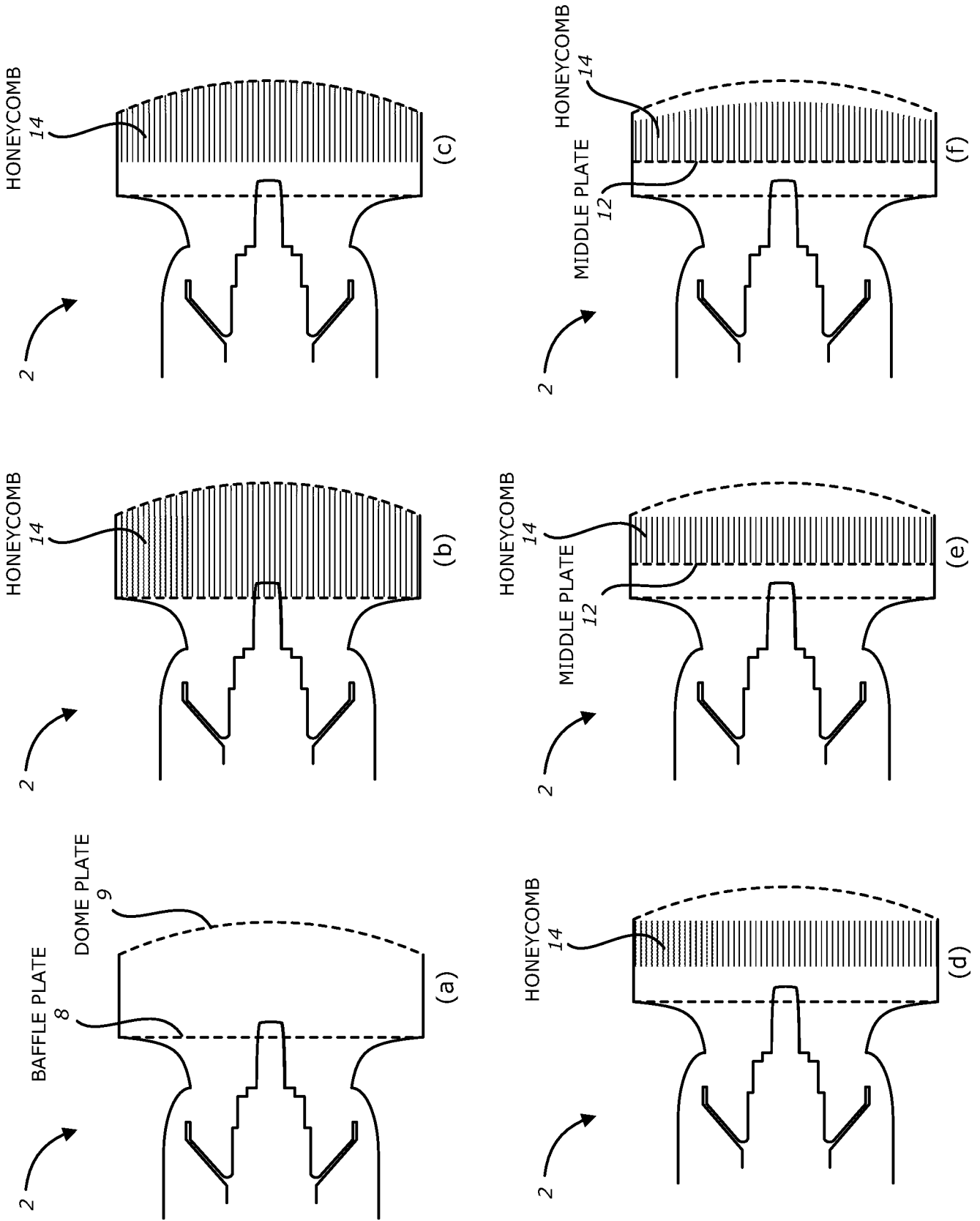

FIG. 11

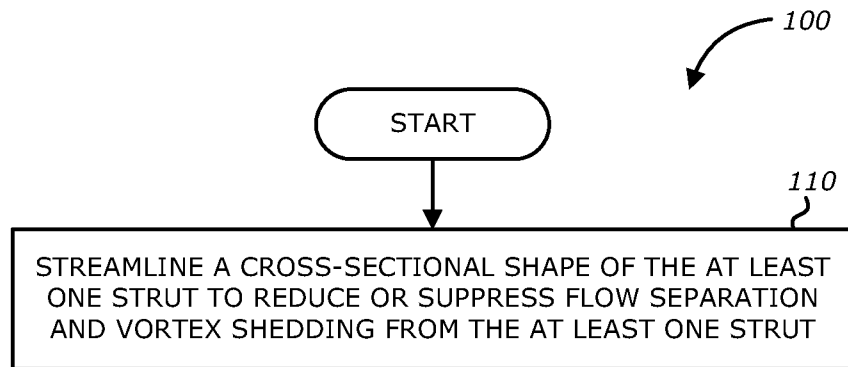

FIG. 12A

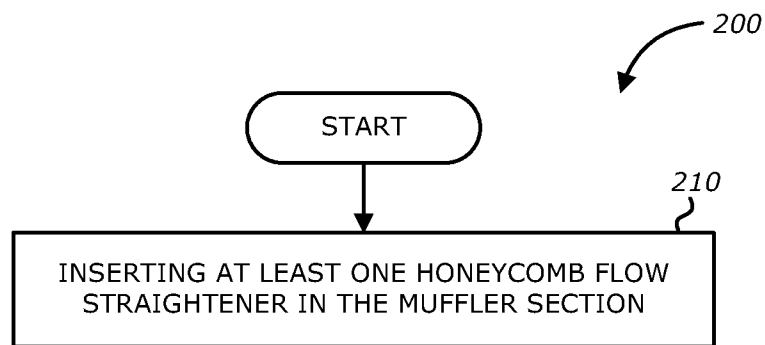

FIG. 12B

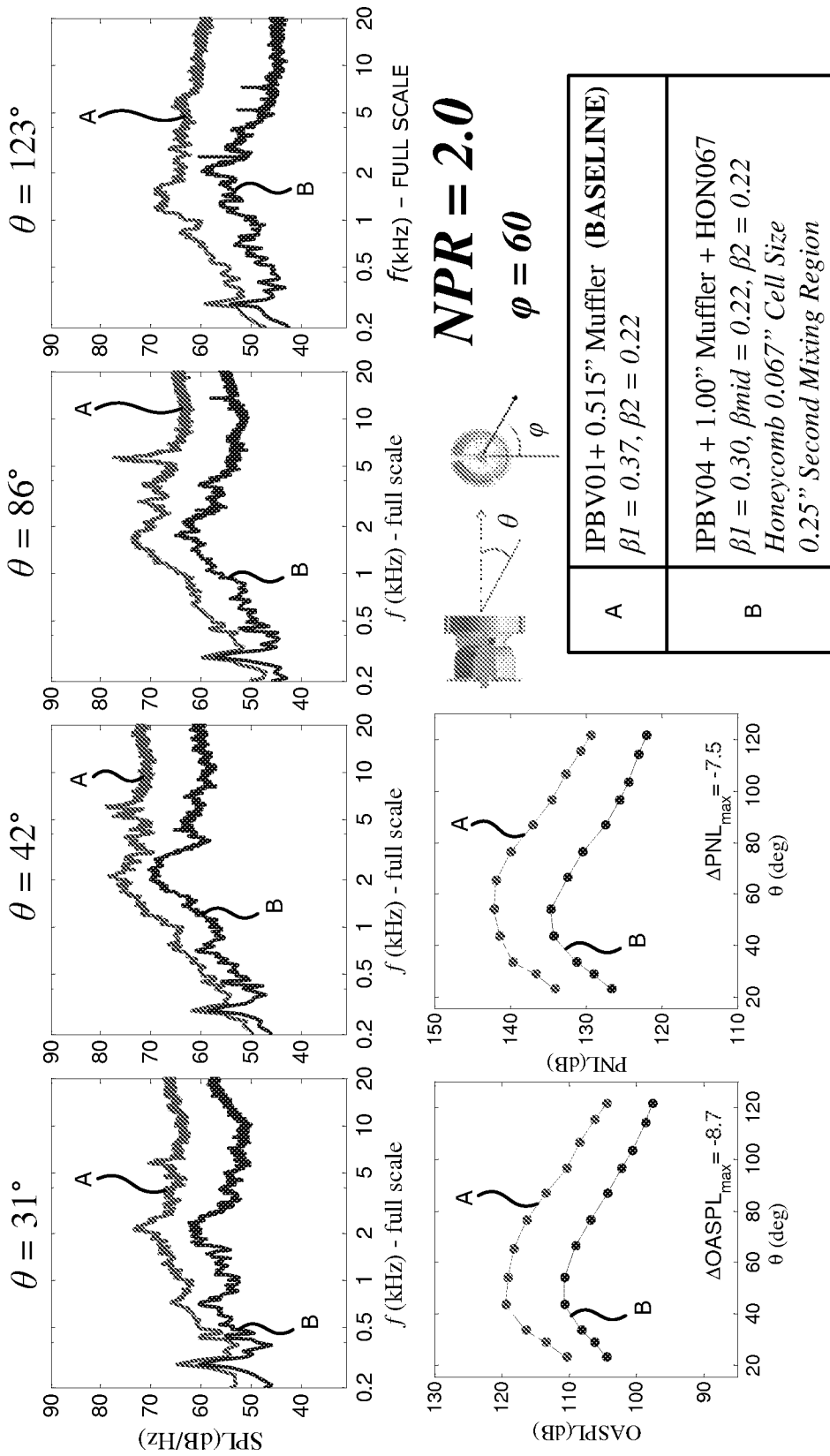

FIG. 13

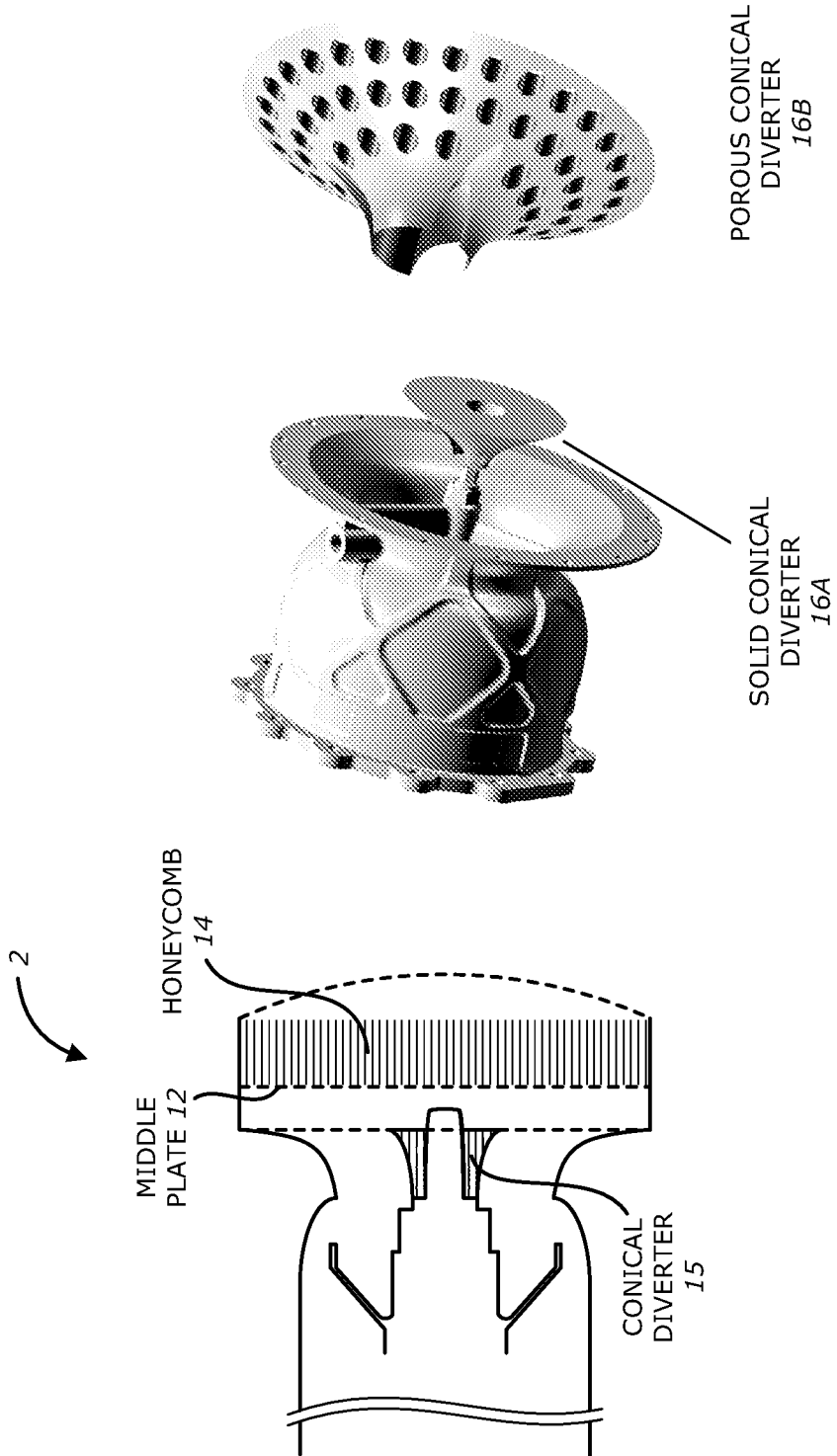

FIG. 14

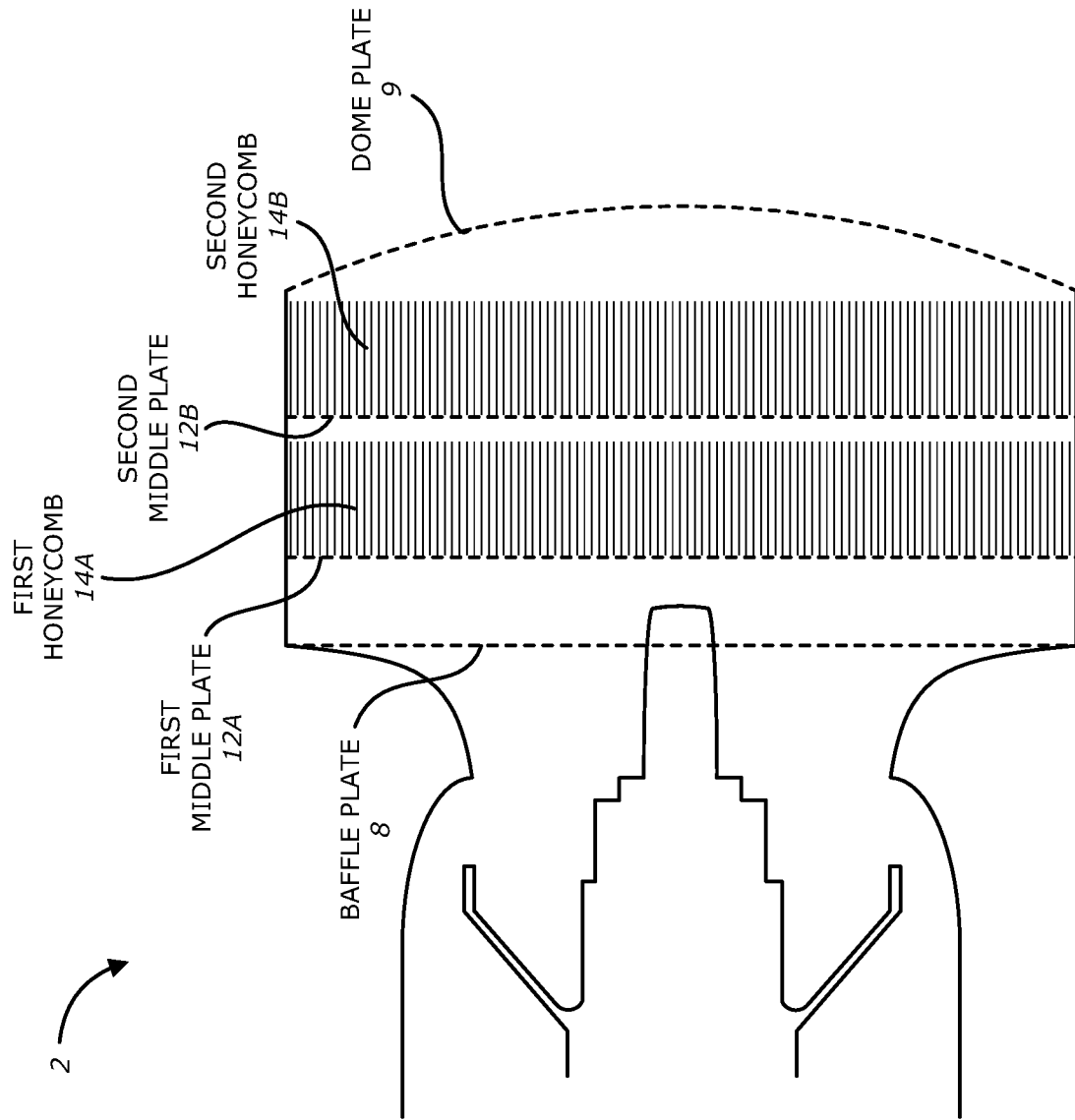

FIG. 15

INTERNATIONAL SEARCH REPORT

International application No.

PCT/US2012/032030

A. CLASSIFICATION OF SUBJECT MATTER

IPC(8) - F02C 9/18 (2012.01)

USPC - 60/785

According to International Patent Classification (IPC) or to both national classification and IPC

B. FIELDS SEARCHED

Minimum documentation searched (classification system followed by classification symbols)

IPC(8) - B64C 1/40; F01N 1/00, 13/02; F02C 6/08, 7/24, 9/00, 9/18; F02K 3/02 (2012.01)

USPC - 60/782, 785, 795; 137/561R; 181/210, 212, 213, 214, 217, 218, 219, 220, 226, 227, 232, 237, 238, 239, 241, 264, 268, 269, 272; 244/1N; 415/119,144,145

Documentation searched other than minimum documentation to the extent that such documents are included in the fields searched

Electronic data base consulted during the international search (name of data base and, where practicable, search terms used)

PatBase

C. DOCUMENTS CONSIDERED TO BE RELEVANT

Category*	Citation of document, with indication, where appropriate, of the relevant passages	Relevant to claim No.
Y	US 2010/0043447 A1 (KIRBY) 25 February 2010 (25.02.2010) entire document	1-46
Y	US 2005/0019156 A1 (D'ANGELO et al) 27 January 2005 (27.01.2005) entire document	1-46
Y	US 3,227,241 A (MATTOON) 04 January 1966 (04.01.1966) entire document	9-26, 30-46

Further documents are listed in the continuation of Box C.

* Special categories of cited documents:

"A" document defining the general state of the art which is not considered to be of particular relevance

"E" earlier application or patent but published on or after the international filing date

"L" document which may throw doubts on priority claim(s) or which is cited to establish the publication date of another citation or other special reason (as specified)

"O" document referring to an oral disclosure, use, exhibition or other means

"P" document published prior to the international filing date but later than the priority date claimed

"T" later document published after the international filing date or priority date and not in conflict with the application but cited to understand the principle or theory underlying the invention

"X" document of particular relevance; the claimed invention cannot be considered novel or cannot be considered to involve an inventive step when the document is taken alone

"Y" document of particular relevance; the claimed invention cannot be considered to involve an inventive step when the document is combined with one or more other such documents, such combination being obvious to a person skilled in the art

"&" document member of the same patent family

Date of the actual completion of the international search

18 June 2012

Date of mailing of the international search report

27 JUN 2012

Name and mailing address of the ISA/US

Mail Stop PCT, Attn: ISA/US, Commissioner for Patents

P.O. Box 1450, Alexandria, Virginia 22313-1450

Facsimile No. 571-273-3201

Authorized officer:

Blaine R. Copenheaver

PCT Helpdesk: 571-272-4300

PCT OSP: 571-272-7774