



Europäisches Patentamt
European Patent Office
Office européen des brevets



(11) **EP 1 090 867 B1**

(12) **EUROPEAN PATENT SPECIFICATION**

(45) Date of publication and mention
of the grant of the patent:
08.09.2004 Bulletin 2004/37

(51) Int Cl.7: **B65H 39/065**, B42C 1/10,
B65H 5/30, B42B 9/02,
B41F 13/68

(21) Application number: **00610103.4**

(22) Date of filing: **09.10.2000**

(54) **Method and device for placing inserts in folded paper jackets**

Verfahren und Vorrichtung zum Anbringen von Beilagen in gefalzten Papierbuchdeckeln

Méthode et dispositif pour placer des encarts dans des couvertures en papier pliées

(84) Designated Contracting States:
**AT BE CH CY DE DK ES FI FR GB GR IE IT LI LU
MC NL PT SE**
Designated Extension States:
AL LT LV MK RO SI

(72) Inventor: **Andersen, Gert Robert
7160 Tarring (DK)**

(30) Priority: **08.10.1999 DK 144999**

(74) Representative: **Nielsen, Leif et al
Patrade A/S
Fredens Torv 3A
8000 Aarhus C (DK)**

(43) Date of publication of application:
11.04.2001 Bulletin 2001/15

(56) References cited:
**EP-A- 0 596 581 DE-A- 3 200 594
US-A- 4 046 367 US-A- 4 373 710
US-A- 5 165 672**

(73) Proprietor: **Schur Packaging Systems a/s
8700 Horsens (DK)**

EP 1 090 867 B1

Note: Within nine months from the publication of the mention of the grant of the European patent, any person may give notice to the European Patent Office of opposition to the European patent granted. Notice of opposition shall be filed in a written reasoned statement. It shall not be deemed to have been filed until the opposition fee has been paid. (Art. 99(1) European Patent Convention).

Description

[0001] The present invention concerns a method and a machine for the placing of so-called inserts in folded printed item, namely newspapers which are supplied in a tight flow with the fold edge foremost, typically from a rotary press with a capacity of 20-25,000 items per hour, and of the kind which comprises a rotating roller with extending, star-shaped support arms which demarcate V-shaped pockets for successive receipt of the arriving printed item by the accommodation of these with the fold edge in towards the bottom of the V-pockets, and opening elements which during the rotation of the roller effect a slight opening of the folded printed item in each of the pockets, and in such a manner that during the movement of the pockets past an insertion station, the thus opened printed items can receive a supplied insert, after which the now supplemented printed items are fed further by the rotation of the roller to or past an extraction station where the finished printed item is extracted from the pockets for further transport, e.g. to a stacking station.

[0002] For the necessary slight opening of the folded printed item, there is the possibility of making use of vacuum means for sucking the opposing outer sides of the printed item respectively against the one side or branch of the respective V-pockets, and on the roller at a distance from here a co-rotating suction head at each of the pockets, but this does not generally provide any security that the printed items will open precisely in the middle, or that they will at all open sufficiently to provide free clearance for the introduction of the insert, especially in light of the quite high speed of operation.

[0003] In most cases, there arises the special situation that the one side edge of the folded items consists of a folded-together or glued-together spine of the printed item product, i.e. at this side it is possible to handle the folded item as if it were an assembled sheet item, including at the said suction outwards, but this will not apply at the opposite side, where the sheets of the printed item are quite loose in relation to one another. Therefore, a practice has been developed whereby a primary opening of the folded printed item at its spine side is effected, either by said separating suction effect or by sideways introduction of a wedge at the centre area of the spine, after which in the clearance established hereby there is introduced a plate winding of a rotating wormscrew structure, which thereafter can successively reproduce the created opening longitudinally to the outer edge area of the folded printed item. This is an excellent solution at lower working speeds, but at an aimed-at capacity of up towards 30,000 items per hour, there is considerable risk that the opening of the folded printed item is not effected in a completely "clean" manner, because the sheets parts in the side opposite the folded spine side and facing towards the opening are not properly fastened on both sides of the opening. Upon introduction of the insert, there can thus occur a crumpling-to-

gether of the sheets and herewith a subsequently incomplete insertion, which can very quickly result in a stop in production, which is especially unfortunate with productions of the kind considered here.

[0004] A corresponding arrangement is known from DE-A-32 00 594, whereby work is effected with the distinct improvement that newspaper items are folded together around a transverse line lying slightly displaced from the centre cross line of the folded-out newspaper, so that opposite the fold line the folded newspaper will appear with two unequally long, out-wardly-extending rectangular edges of the respective half-parts of the folded newspaper. This provides the possibility that use can be made of edge gripping means for secure gripping of the free edge of the one folded half part, while relying on the fact that by means of gravitation the other half part can bring about the necessary opening of the folded item to enable an insert to be introduced into the opening. At high working speeds, however, this gravitational effect will not only be too slow but also be of uncertain influence on the folded item, i.e. this method is not suitable for use at the higher speeds of operation.

[0005] However, it has also been realised, cf. US-4,046,367 and US-4,373,710, that it will be possible to bring about a controlled gripping also of the opposite free edge of the asymmetrically-folded product, so that this can be forcibly opened for quick introduction of the insert, but it has herewith been a problem that relevant gripping means in the form of curved hook parts which can be swung inwards require that the protruding free edge on the asymmetrically-folded printed items has an otherwise undesirably great over-height in order to be able to achieve a gripping effect of maximum reliability.

[0006] Here it must be taken into consideration that, in practice, certain crookedness can arise in the folding of the printed items, so that the said over-height of the protruding free edge can be considerably less at the one side than at the other side of the items. This will involve that the over-height, which is already too great, must be even greater, namely in order to ensure a sufficiently great free height for reliable gripping of the free edge at both sides.

[0007] The gripping reliability is of decisive importance, and with the present invention it is endeavoured to provide a combination of high gripping security and minimised demands regarding the over-height of the protruding free edge.

[0008] Consequently, as starting point for each of the receiving pockets, use is made of a fixed wing and, at the root hereof, a pivotally mounted pressure rail, and the folded newspapers are received with the low folded half part facing towards the fixed wing, which outermost/uppermost has a set of curved, gripping hooks which can be swung inwards for forced-control gripping of the free edge of the low folded half part, quite as known from e.g. US-A-4,373,710. With the invention, however, it is arranged that after the folded newspaper has been fed to the pocket, the pressure rail is activated

to swing-in against the fixed wing, so that the folded item will generally be held firmly pressed while the swinging-in of the said gripping hooks is effected. By this swinging-in, the gripping hooks shall wedge themselves in the space between the two folded half parts during the pressing back of the longest protruding half part, which according to the invention is made possible in that the pressure rail, along a part of its outermost extent, is configured with an outwardly, rearwards-inclined profile which will allow said wedging-in while the clamping-fast of the folded item is otherwise maintained. This clamping-fast during the gripping operation will obviously promote operational reliability.

[0009] A second important and even primary characteristic of the invention is that the gripping means, which are arranged at the outer end of the pivotal pressure rail, are not forcibly moved, but merely consist of projecting, passive, pivotal hook part which with an outer, inclined gripping hook will be forced to swing up over the outer edge of the longest protruding half part of the folded newspaper when this is clamped-in by the tilting forward of the pressure rail. With this simple drop-hook locking, which is controlled by the fold item itself, a reliable gripping can be achieved without the said over-height needing to be quite great.

[0010] Thereafter, the pressure rail can be tipped out for opening of the folded item for receiving the insert. During the end phase of the tipping back or out of the pressure rail, the gripping hooks can be made to release their grip in the simple manner that with an inclined, rearwards-extending release arm part, they impinge against a release cam on the next following fixed wing, so that the gripping hook is forced to swing out from the engagement with the gripped edge of the item. Thereafter, the pressure rail can be swung back to an almost closed position of the pocket, where the item with its associated insert can be extracted by suitable extraction means after the releasing of the controlled grippers for the lowest protruding edge part of the item.

[0011] In the following, the arrangement and mode of operation of an example embodiment are explained in more detail with reference to the drawing, in which

Fig. 1 is a schematic side view of an insert machine of the relevant type, while

Fig. 2 is a more detailed view of a wing-wheel according to the invention used herein, and

Figs. 3-10 are detail views to illustrate the function of this wheel.

[0012] The machine sketched in fig. 1 works in accordance with well-known principles. The main element is a wing wheel 2 which has protruding wing-rods 4 which form V-shaped pockets for receiving folded newspapers 6 delivered in a flow from a rotary press with the fold edge foremost. The rotation of the wheel 2 is controlled in such a manner that it can hereby receive a sin-

gle newspaper in each of the wheel pockets.

[0013] At a level over the wheel 2, a magazine unit is provided for stacks of inserts 8 in respective magazines 10. From one or more of these magazines, the inserts can be dropped individually down onto a conveyor belt 12, controlled in such a way that inserts from selected magazines can be successively deposited in insert sets 14. Via a suitable transfer conveyor, these inserts or insert sets can be fed for introduction down into the wheel pockets, in which as shown at 16 the newspapers are held opened for reliable receipt of the inserts in the centre fold. Hereafter, the wheel pockets are moved further through an extraction station 18 at which the supplemented newspapers are extracted for feeding further along a conveyor 20 for final stacking or further processing.

[0014] The relevant task will hereby be to provide maximum security for the opening of the centre fold 16 of the newspapers, so that it can be ensured that the inserts 8, 14 are inserted in a "clean" manner, also at high working speeds. In order for this to be achieved, the wing wheel 2 according to the invention is arranged in the following manner, cf. fig. 2.

[0015] The fixed wings 4 are configured in a tapering manner with a curved front edge forwards in the direction of rotation and with a straight rear edge. On the tip of the wing, mounted in a pivotal manner on a transverse axle 22, there is a hook element 24 which extends in an arc from a base part over an angle of approx. 90°, and which in a normal position has a free end lying outside the wing tip. The hook element is connected to a pinion 26 which cooperates with a rack 28 outermost on a push rod 30, which via a slide guide 32 extends in to a fixed hub part 34 configured with a control cam 36 which, by co-operation with a cam follower 38 on the rod 30, can slide this outwards so that the rack 28 and herewith the hook element 24 is swung downwards to the rear.

[0016] The same wing 4 has a pressure rail 40 lying behind at the rear edge of the wing, pivotally fastened at 42 to the outer end of a support arm 44 which is mounted extending out from a support block 46. This support block 46 is pivotally fastened to the hub of the wheel by a bearing 48, and is provided with a cam-follower roller 50 for co-operation with a fixed control cam 52. The support arm 44 can hereby be controlled for swinging forwards against the rear edge of the wing 4, where the pressure rail 40 can thus be tilted out around the bearing 42 to assume a position parallel with this rear edge (fig. 4).

[0017] At its outermost end, the pressure rail 40 has a rocker arm 54 which is pivotally mounted at 56, and which outermost supports a projecting hook part 58 with a gripping hook 60 extending inwards. This arm can be pivoted between the protruding position shown in fig. 2 and the swung rearwards position shown in fig. 3, where the gripping hook 60 is drawn back into abutment against the front side of the outer end of the pressure rail 40. This latter position is a normal position, in that

the upper end of the rocker arm is spring-loaded in the rearwards direction.

[0018] The outer end part of the pressure rail 40 is characterised in that it is formed with an outwards/rearwards inclined section as shown at 62.

[0019] In the receive position for the insertion of printed items 6, fig. 3, the support arm 44 and the pressure rail 40 will be swung completely backwards against the succeeding fixed wing 4, whereby the outer end of the rocker arm 54 is pressed against a rear edge flange 5 on the succeeding wing, so that the hook part 58 and the gripping hook 60 will be protruding from the pressure rail 40. There will now be plenty of room in the "pocket" 64 between the wings for safe receipt of the arriving newspaper.

[0020] Immediately afterwards, the support arm 44 is swung forwards (upwards) against its related fixed wing 4 for clamping the closed-together newspaper against this, namely with the view thereafter of being able to open the folded newspaper. From the printing press, the newspaper is folded in a slightly asymmetric manner, so that its rearmost half part in the direction of rotation extends slightly to the rear as shown at 66 in fig. 3.

[0021] After the introduction of the newspaper 6, the support arm 44 and herewith the pressure rail 40 are forced upwards/forwards under rotation of the wheel, whereby the pocket 64 is gradually closed, cf. fig. 4. At the position shown in fig. 5, the shortest protruding half-part of the folded newspaper has almost reached forward to the fixed wing 4, while the longer protruding edge part 66 of the other half-part abuts against the front end of the force-controlled hook element. 24. Under the further relative swinging-forward of the pressure rail 40, the gripping hook 60 on the hook part 58 will be pressed forward over the yielding outer edge of the rearmost, longest protruding edge part 66 of the newspaper item 6, which can be effected partly by a certain bending forward of this edge part, and partly by a certain degree of swinging-out of the hook part 58 brought about by the rearwards-inclined section of the gripping hook 60 itself, cf. fig. 6.

[0022] With a subsequent full clamping of the newspaper item against the fixed wing 4, the pressure rail 40 will be pressed in a parallel manner against the wing for good securing of the newspaper item despite an angled-out position of the support arm 44, with possibility herewith for automatic adjustment to newspaper items of different thickness.

[0023] In a concluding clamping position, the pressure pin 55 will be pressed against the fixed wing 4 via the clamped-together newspaper, whereby the rocker arm 54 will swing the gripping hook 60 further forward, cf. fig. 7, whereby the gripping hook 60 will grip in over the high edge area 66 of the newspaper with increased security. By swinging around the swivel bearing 42, the pressure rail 40, which in the free state is clamped flexibly against the support arm 44, will lie flat in against the newspaper regardless of its thickness.

[0024] Thereafter, both edges of the newspaper will be securely gripped, and the pressure rail 40 can then be controlled for quick re-opening of the pocket 64, fig. 8, in that the gripping hook 60 will swing towards the right and thus bring the edge area 66 with it when the pressure pin 55 leaves its firm abutment against the clamped-in newspaper. Hereafter, the introduction of the insert 14 can be initiated.

[0025] When the pressure rail is swung all the way back, fig. 9, the release arm 61 on the hook part 58 will abut up against the stop 63, whereby the hook part 58 and the gripping hook 60 is swung up for the releasing of the edge area 66, which of its own accord will straighten out from the inclined surface 62 of the pressure rail. In fig. 2, a protruding pressure lug 68 is shown on the fixed wing 4 lying behind, and this lug will ensure a relative pressing-out of the edge area 66 from the gripping hook 60. In practice, however, it has been found possible to omit these pressure lugs, which are rendered superfluous by the existence of the inclined surfaces 62. In its swung upwards and rearwards position, the gripping hook 60 will be lying over the top of the pressure rail 40, whereby the releasing of the newspaper edge is effected with full security.

[0026] Thereafter, the pressure rail can again be swung forwards for partial closing of the pocket 64 during the further swinging-down of the wing to the delivery position shown in fig. 10. Just before this position is reached, the hook element 24 on the fixed wing is controlled for opening, after which the newspaper into which the insert has been introduced is ready to be conveyed out by known means.

35 Claims

1. Method for the placing of inserts in folded printed items (6) such as newspapers which are supplied from e.g. a rotary press with high capacity, by which method the printed items (6) are fed in hanging condition with their fold edge lowermost, and are made to fall successively into V-shaped pockets (64) formed by star-shaped wings (4) extending on a rotating wing wheel (2), and are subsequently partly unfolded in these pockets for the receipt of the relevant insert(s) (8,14), after which the printed items (6) are successively conveyed from the pockets (64), said printed items being folded in such a manner that the fold is displaced from the centreline, so that opposite the fold edge they have a shorter side part and a longer side part extending out to form a protruding edge (66), which on the printed items lies rearmost in the direction in which they are fed, **characterised in that** the printed item (6) which falls down into the pocket (64) is influenced in the forwards direction for clamping abutment against the rear edge of the foremost wing (4) of the pocket,

a hook element (24) is first swung downwards to the rear and then inwards behind the outer edge area of the shorter side part for the retaining of this side part,

a pressure rail (40), pivotally suspended in the pocket and with an outer, projecting gripping hook (60), is thereafter swung forwards to a position in which the gripping hook (60) extends in front of the protruding edge (66),

thereafter, the pressure rail (40) is swung rearwards while bringing with it the protruding edge (66) of the printed item (6), which is now retained by the gripping hook (60), for the opening of the printed item (6) immediately before the introduction of the insert (8,14),

thereafter or at the same time herewith, the gripping hook (60) is influenced for the release of the protruding edge (66),

the pressure rail (40) is thereafter swung forwards again for complete or partial folding-together of the printed item, and

the printed item (6) is then conveyed out of the pocket (64), if necessary after a short swinging back of the pressure rail (40).

2. Machine for the placing of inserts in folded printed items (6) such as newspapers which are supplied from e.g. a rotary press with high capacity, by a method according to which the printed items (6) are fed in hanging condition with their fold edge lowermost, and are made to fall successively into V-shaped pockets (64) formed by star-shaped wings (4) extending on a wing wheel (2), and are subsequently partly unfolded in these pockets for the receipt of the relevant insert(s) (8,14), after which the printed items (6) are successively conveyed from the pockets (64), said printed items being folded in such a manner that the fold is displaced from the centreline, so that opposite the fold edge they have a shorter side part and a longer side part extending out to form a protruding edge (66), which on the printed items lies rearmost in the direction in which they are fed, **characterised in that**

it comprises a pressure rail (40) which is mounted pivotally on a bearing (42) on a support arm (44) and is arranged for being influenced in the forwards direction for bringing the printed item in clamping abutment against the rear edge of the foremost wing (4) of the pocket,

a hook element (24) is mounted in a pivotal manner on the tip of the wing and is arranged to be swung downwards to the rear and inwards behind the outer edge area of the shorter side part for the retaining of this side part,

said pressure rail (40) is provided with a pivotally rocker arm (54) provided with an outer, projecting gripping hook (60) and being arranged to be swung forwards to a position in which the gripping hook

(60) extends in front of the protruding edge (66), and rearwards while bringing with it the protruding edge (66) of the printed item (6), which is now retained by the gripping hook (60), for the opening of the printed item (6) immediately before the introduction of the insert (8,14),

a release arm (61) is connected with the gripping hook (60) and is arranged to cooperate with a stop (63) for swinging up the gripping hook (60) for the release of the protruding edge (66) before the printed item (6) is conveyed out of the pocket (64), if necessary after a short swinging back of the pressure rail (40).

Patentansprüche

1. Verfahren zum Anordnen von Inserts in gefalteten Druckerzeugnissen (6) wie etwa Zeitungen, die von einer Rotationspresse hoher Kapazität zugeführt werden, wobei durch das Verfahren die Druckerzeugnisse (6) in einem hängenden Zustand, in dem sich ihre Faltkante unten befindet, vorgeschoben und dazu veranlasst werden, nacheinander in V-förmige Taschen (64) zu fallen, die durch sternförmige Flügel (4) gebildet sind, die sich von einem rotierenden Flügelrad (2) erstrecken, und anschließend in diesen Taschen teilweise aufgefaltet werden, um das oder die entsprechenden Inserts (8, 14) aufzunehmen, woraufhin die Druckerzeugnisse (6) nacheinander aus den Taschen (64) befördert und in der Weise gefaltet werden, dass die Faltung von der Mittellinie versetzt ist, so dass sie gegenüber der Faltkante einen kürzeren Seitenabschnitt und einen längeren Seitenabschnitt besitzen, die sich nach außen erstrecken, um eine vorstehende Kante (66) zu bilden, die auf den Druckerzeugnissen in ihrer Vorschubrichtung am weitesten hinten liegt, **dadurch gekennzeichnet, dass**

das Druckerzeugnis (6), das in die Tasche (64) herunterfällt, in Vorwärtsrichtung beeinflusst wird, um einen Klemmanschlag an der Hinterkante des vordersten Flügels (4) der Tasche zu erzielen, ein Hakenelement (24) zuerst in Abwärtsrichtung nach hinten und dann nach innen hinter den äußeren Kantenbereich des kürzeren Seitenabschnitts geschwenkt wird, um diesen Seitenabschnitt zu halten,

eine Druckschiene (40), die in der Tasche schwenkbar aufgehängt ist und einen äußeren, vorstehenden Greifhaken (60) besitzt, anschließend nach vorn in eine Position geschwenkt wird, in der sich der Greifhaken (60) vor die vorstehende Kante (66) erstreckt,

danach die Druckschiene (40) nach hinten geschwenkt wird und dabei die vorstehende Kante (66) des Druckerzeugnisses (6) mitnimmt, die nun durch den Greifhaken (60) gehalten wird, um das

Druckerzeugnis (6) unmittelbar vor dem Einführen des Inserts (8, 14) zu öffnen,

danach oder gleichzeitig damit der Greifhaken (60) beeinflusst wird, damit er die vorstehende Kante (60) freigibt,

die Druckschiene (40) anschließend erneut nach vorn geschwenkt wird, um das Druckerzeugnis vollständig oder teilweise zusammenzufalten, und

das Druckerzeugnis (6) anschließend aus der Tasche (64) befördert wird, gegebenenfalls nach einem kurzen Zurückschwingen der Druckschiene (40).

2. Maschine zum Anordnen von Inserts in gefalteten Druckerzeugnissen (6) wie etwa Zeitungen, die beispielsweise von einer Rotationspresse hoher Kapazität zugeführt werden, durch ein Verfahren, bei dem die Druckerzeugnisse (6) in einem hängenden Zustand, in dem ihre Faltecke unten hängt, vorgeschoben und dazu veranlasst werden, nacheinander in V-förmige Taschen (64) zu fallen, die durch sternförmige Flügel (4) gebildet sind, die sich von einem Flügelrad (2) erstrecken, und anschließend in diesen Taschen teilweise aufgefaltet werden, um das oder die entsprechenden Inserts (8, 14) aufzunehmen, woraufhin die Druckerzeugnisse (6) nacheinander aus den Taschen (64) befördert werden, wobei die Druckerzeugnisse in der Weise gefaltet werden, dass die Faltung von der Mittellinie versetzt ist, so dass sie gegenüber der Faltecke einen kürzeren Seitenabschnitt und einen längeren Seitenabschnitt besitzen, der sich nach außen erstreckt und eine vorstehende Kante (66) bildet, die auf den Druckerzeugnissen in ihrer Vorschubrichtung am weitesten hinten liegt, **dadurch gekennzeichnet, dass**

sie eine Druckschiene (40) umfasst, die an einem Auflager (42) an einem Unterstützungsarm (44) schwenkbar angebracht und so beschaffen ist, dass sie in Vorwärtsrichtung beeinflusst wird, um das Druckerzeugnis in einen Klemmanschlag an der Hinterkante des vordersten Flügels (4) der Tasche zu bringen,

das Hakenelement (24) an der Spitze des Flügels schwenkbar angebracht und so angeordnet ist, dass es in Abwärtsrichtung nach hinten und nach innen hinter den Außenkantenbereich des kürzeren Seitenabschnitts geschwenkt wird, um diesen Seitenabschnitt zu halten,

die Druckschiene (40) mit einem schwenkbaren Kipparm (54) versehen ist, der mit einem äußeren, vorstehenden Greifhaken (60) versehen und so angeordnet ist, dass er nach vorn in eine Position geschwenkt werden kann, in der sich der Greifhaken (60) vor die vorstehende Kante (66) erstreckt, und nach hinten geschwenkt werden kann und dabei die vorstehende Kante (66) des Druckerzeug-

nisses (6) mitnimmt, die nun durch den Greifhaken (60) gehalten wird, um das Druckerzeugnis (6) direkt vor dem Einführen des Inserts (8, 14) zu öffnen,

ein Freigabearm (61) mit dem Greifhaken (60) verbunden und so angeordnet ist, dass er mit einem Anschlag (63) für das Hochschwenken des Greifhakens (60) zusammenwirkt, um die vorstehende Kante (66) freizugeben, bevor das Druckerzeugnis (6) aus der Tasche (64) befördert wird, gegebenenfalls nach einem kurzen Zurückschwenken der Druckschiene (40).

Revendications

1. Méthode pour placer des encarts dans des envois imprimés pliés (6) comme par exemple des journaux qui sont livrés par exemple d'une presse rotative de capacité élevée, par laquelle méthode les envois imprimés (6) sont transportés dans un état suspendu avec leurs arêtes pliées en bas et sont faits pour tomber successivement dans des poches en forme de V (64) formées par des ailes en forme d'étoiles (4) s'étendant sur une roue à ailettes rotative (2), et sont ensuite partiellement déployés dans ces poches pour recevoir l'encart (les encarts) pertinent(s) (8, 14), après quoi les envois imprimés (6) sont successivement convoyés des poches (64), lesdits envois étant pliés de manière à ce que le pli est déplacé de la ligne centrale de sorte que opposé à l'arête pliée, ils possèdent une partie latérale plus courte et une partie latérale plus longue s'étendant vers l'extérieur pour former une feuillure (66) qui sur les envois imprimés est située le plus en arrière dans la direction de déroulement, **caractérisée en ce que** l'envoi imprimé (6) qui tombe dans la poche (64) est influencé dans la direction d'avance pour l'appui serré contre l'arête arrière de l'aile antérieure (4) de la poche, un élément de crochet (24) est d'abord pivoté vers le bas vers l'extrémité arrière et ensuite vers l'intérieur derrière la zone de l'arête extérieure de la partie latérale plus courte pour maintenir cette partie latérale, un rail de pression (40) suspendu de manière pivotante dans la poche et possédant un crochet préhenseur en saillie extérieur (60) est ensuite pivoté vers l'avant dans une position dans laquelle le crochet préhenseur (60) s'étend devant la feuillure (66), ensuite le rail de pression (40) est pivoté vers l'arrière en amenant le feuillure (66) de l'envoi imprimé (6), qui maintenant est maintenu par le crochet préhenseur (60), pour l'ouverture de l'envoi imprimé (6) immédiatement avant l'insertion des encarts (8, 14), ensuite ou en même temps, le crochet préhenseur (60) est activé pour le dégagement de la feuillure (66), le rail de pression (40) est ensuite pivoté vers l'avant

encore une fois pour le pliage complet ou partiel de l'envoi imprimé, et l'envoi imprimé (6) est ensuite transporté en dehors de la poche (64), si c'est nécessaire après un court pivotement de retour du rail de pression (40). 5

2. Machine pour placer des encarts dans des envois imprimés pliés (6) comme par exemple des journaux qui sont livrés par exemple d'une presse rotative de capacité élevée, par une méthode selon laquelle les envois imprimés (6) sont transportés dans un état suspendu avec leurs arêtes pliées en bas et sont faits pour tomber successivement dans des poches en forme de V (64) formées par des ailes en forme d'étoiles (4) s'étendant sur une roue à ailettes (2), et sont ensuite partiellement déployés dans ces poches pour recevoir l'encart (les encarts) pertinent(s) (8, 14), après quoi les envois imprimés (6) sont successivement convoyés des poches (64), lesdits envois étant pliés de manière à ce que le pli est déplacé de la ligne centrale de sorte que opposé à l'arête pliée, ils possèdent une partie latérale plus courte et une partie latérale plus longue s'étendant vers l'extérieur pour former une feuillure (66) qui sur les envois imprimés est située le plus en arrière dans la direction de déroulement, **caractérisée en ce que** 10 15 20 25
- elle comporte un rail de pression (40) qui est monté de manière pivotante sur un palier (42) d'un bras de support (44) et est disposé à être activé dans la direction d'avance pour mettre l'envoi imprimé dans l'appui serré contre l'arête arrière de l'aile antérieure (4) de la poche, 30
- un élément de crochet (24) est monté de manière pivotante sur le bout d'aile et est disposé à être pivoté vers le bas vers l'arrière et vers l'intérieur derrière la zone de l'arête extérieure de la partie latérale plus courte pour maintenir cette partie latérale, ledit rail de pression (40) est muni d'un bras oscillant pivotant (54) prévu d'un crochet préhenseur en saillie extérieur (60) et est disposé à être pivoté vers l'avant dans une position dans laquelle le crochet préhenseur (60) s'étend devant la feuillure (66) et vers l'arrière en amenant la feuillure (66) de l'envoi imprimé (6) qui maintenant est maintenu par le crochet préhenseur (60) pour l'ouverture de l'envoi imprimé (6) immédiatement avant l'insertion de l'encart (8, 14), 35 40 45
- un bras de dégagement (61) est lié au crochet préhenseur (60) et est disposé à coopérer avec une butée (63) pour le pivotement en haut du crochet préhenseur (60) pour le dégagement de la feuillure (66) avant que l'envoi imprimé (6) soit transporté de la poche (64) si nécessaire après un court pivotement en arrière du rail de pression (40). 50 55

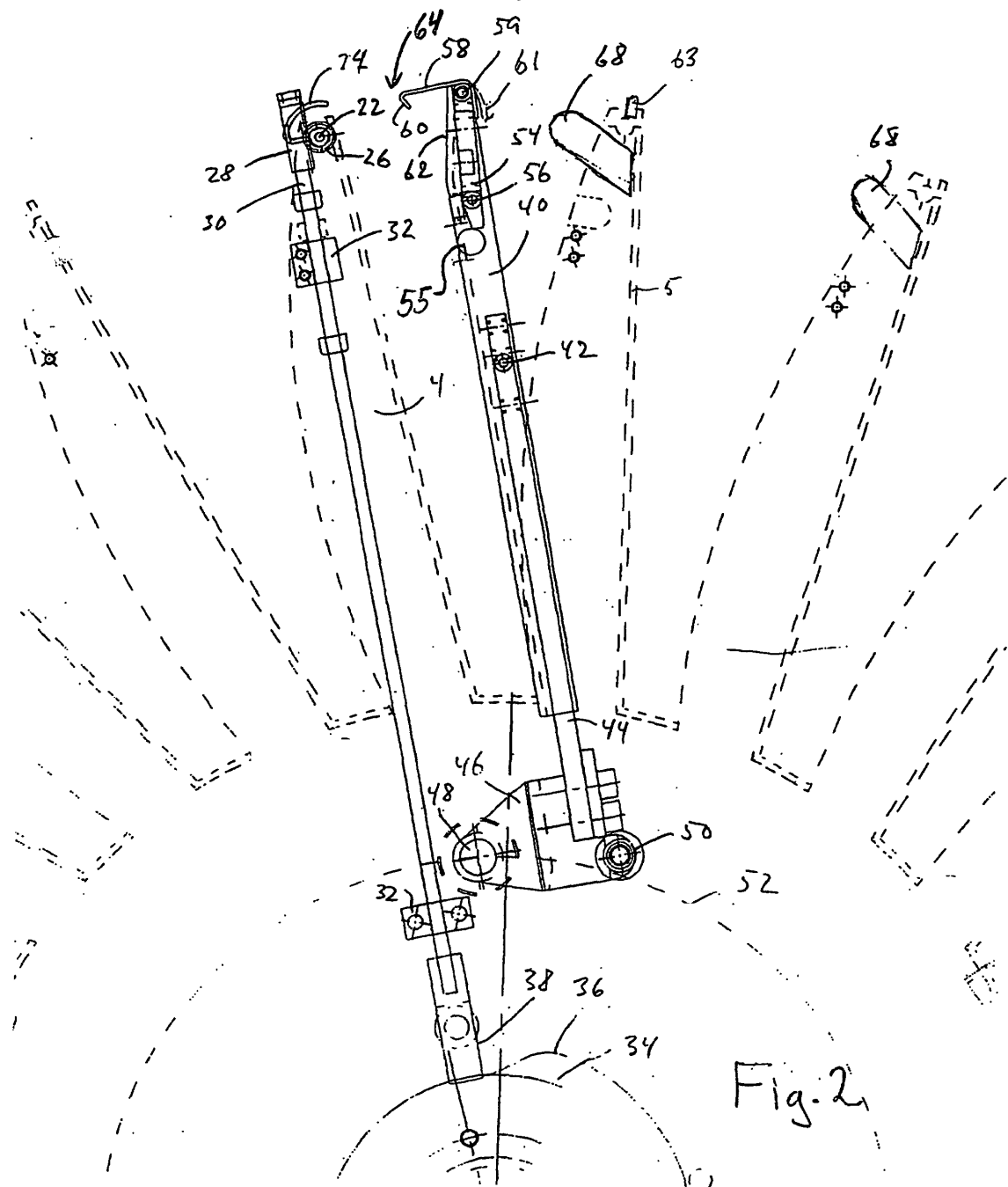
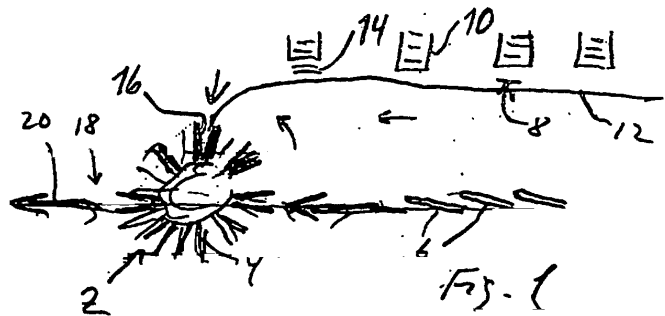

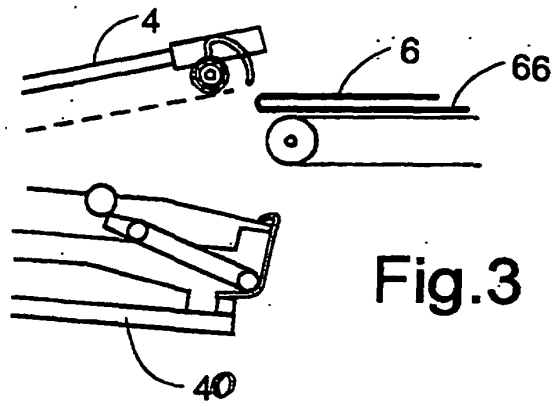

Fig. 4

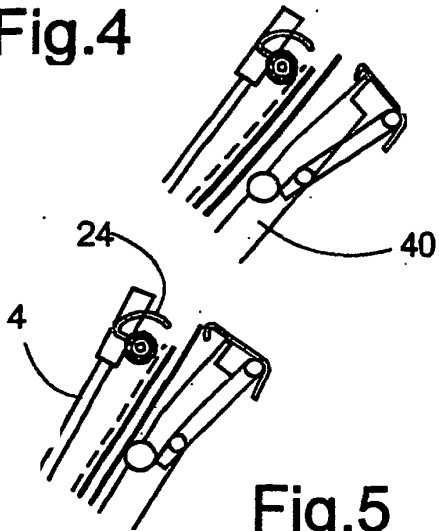

Fig. 5

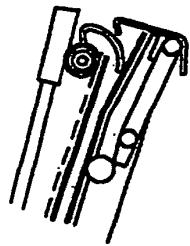

Fig. 6



Fig. 8

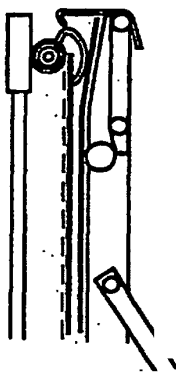
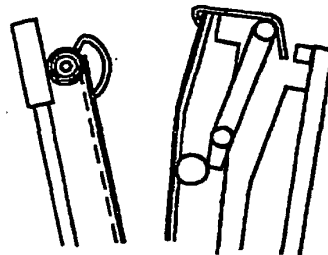

Fig. 7

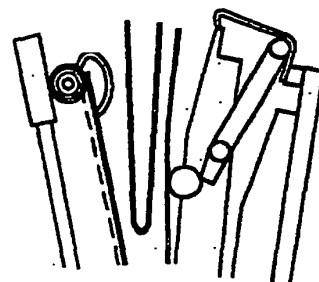

Fig. 9

Fig. 10

